

# TQ6702e GEN2

OUTDOOR WIRELESS ACCESS POINTS

AT-TQ6702e GEN2

AT-TQ6702e GEN2-R

802.11ax Dual-radio 5GHz/2.4GHz 8x8+4x4 Wireless AP



455-1

## Installation Guide

Copyright © 2025 Allied Telesis, Inc.

All rights reserved. No part of this publication may be reproduced without prior written permission from Allied Telesis, Inc.

Allied Telesis and the Allied Telesis logo are trademarks of Allied Telesis, Incorporated. All other product names, company names, logos or other designations mentioned herein are trademarks or registered trademarks of their respective owners.

Allied Telesis, Inc. reserves the right to make changes in specifications and other information contained in this document without prior written notice. The information provided herein is subject to change without notice. In no event shall Allied Telesis, Inc. be liable for any incidental, special, indirect, or consequential damages whatsoever, including but not limited to lost profits, arising out of or related to this manual or the information contained herein, even if Allied Telesis, Inc. has been advised of, known, or should have known, the possibility of such damages.

# Table of Contents

---

<b>Preface</b> .....	8
Safety Symbols Used in this Document .....	9
Translated Safety Statements .....	10
Professional Installation Instructions .....	11
Contacting Allied Telesis .....	12
<b>Chapter 1: Product Description</b> .....	<b>13</b>
Features of the TQ6702e GEN2 Access Points .....	14
Management Tools .....	16
Web Browser .....	16
Vista Manager EX and AWC Plug-in .....	16
SNMPv1 and v2c .....	16
TQ6702e GEN2 Access Points .....	17
LAN Port .....	18
Power over Ethernet (PoE++) .....	19
Connector Type .....	19
Speed .....	19
Duplex Mode .....	19
Automatic MDIX Detection .....	20
Maximum Distance .....	20
Port Pinouts .....	20
LEDs .....	20
Reset Button .....	21
Ethernet Cable Requirements .....	22
Maximum Distance .....	22
TQ0301 Patch Antenna and TQ0064 RF Extension Cable .....	23
<b>Chapter 2: Installing the Access Point</b> .....	<b>25</b>
Reviewing Safety Precautions .....	26
Unpacking the Access Point .....	28
Attaching the Ground Cable to the Access Point .....	31
Guidelines to Attaching the Ground Cable .....	31
What to Prepare for Attaching the Ground Cable .....	31
Attaching the Ground Cable to the Access Point .....	31
Connecting an Ethernet Cable to the Access Point .....	34
Attaching the Antennas to the Access Point .....	38
Installing the Access Point .....	41
Guidelines to Installing the Access Point on a Fixture .....	41
Installation Instructions .....	43
Installing the Access Point on a Wall .....	44
What to Prepare for Wall Installation .....	44
Installing the Access Point on a Wall .....	44
Installing the Access Point on a Pole .....	48
Two Methods to Install the Access Point on a Pole .....	48
Vertical Pole and Horizontal Pole .....	49
Guidelines for Pole Installation .....	50
Installing on a Pole Using the U-Bolts and Pole-Mount Bracket .....	51

What to Prepare for Pole Installation Using the U-Bolts and Pole-Mount Bracket .....	51
Installing the Access Point on a Pole Using the U-Bolts and Pole-Mount Bracket .....	51
Adjusting the Position Upwards or Downwards .....	53
Installing on a Pole Using the Pole Straps and Mounting Base .....	54
What to Prepare for Pole Installation Using the Pole Straps and Mounting Base .....	54
Installing the Access Point on a Pole Using the Pole Straps and Mounting Base .....	54
Starting the First Management Session .....	59
Setting the Country and Location .....	61
Setting the Country .....	61
Setting the Location .....	62
Rebooting the Access Point .....	63
<b>Chapter 3: Installing the TQ0301 Patch Antenna and TQ0064 Extension Cable .....</b>	<b>64</b>
Unpacking the TQ0301 Dual-band Patch Antenna .....	65
Unpacking the TQ0064 Extension Cable .....	67
Installing the TQ0301 Patch Antenna on a Pole .....	68
Guideline for Pole Installation .....	68
Attaching the Cables to the TQ0301 Patch Antenna .....	69
Installing the TQ0301 Antenna and TQ6702e GEN2 Access Point .....	70
Attaching the Cable to the TQ6702e GEN2 Access Point .....	71
<b>Appendix A: Technical Specifications .....</b>	<b>73</b>
TQ6702e GEN2 Access Point Specifications .....	74
Physical Specifications .....	74
Environmental Specifications .....	74
Power Specifications .....	74
Antenna Specifications .....	75
TQ0301 Patch Antenna Specifications .....	76
Physical Specifications .....	76
Environmental Specifications .....	76
Product Specifications .....	76
Power Specifications .....	77
TQ0064 and Cables in TQ6702e GEN2 Access Points Specifications .....	78
Physical Specifications .....	78
Environmental Specifications .....	78
Product Specifications .....	78
Power Specifications .....	78
LAN Port .....	79
Operation Frequency Information .....	81
<b>Appendix B: Regulatory Statements .....</b>	<b>82</b>
Federal Communications Commission Interference Statement .....	83
Industry Canada Statement .....	85
IC Radiation Exposure Statement .....	85
Déclaration d'exposition à la radiation .....	85
Caution .....	85
Avertissement .....	86
Professional Installation Instruction .....	86
Instructions d'installation professionnelle: .....	86
Europe - EU Declaration of Conformity .....	87
Operating Frequencies and Maximum Transmission Power Levels .....	87
Radiation Exposure Statement .....	87
Importer .....	87
UK - UKCA Declaration of Conformity .....	88
Operating Frequencies and Maximum Transmission Power Levels .....	88
Radiation Exposure Statement .....	88

Importer .....	88
European Union Restriction of the Use of Certain Hazardous Substances (RoHS) in Electrical and Electronic Equipment .....	89
<b>Appendix C: Radiation Patterns .....</b>	<b>90</b>
Antenna Locations and Axes .....	91
2.4/5GHz Dual (2.4GHz) Radiation Patterns .....	91
2.4/5GHz Dual (5GHz) Radiation Patterns .....	92
5GHz Single (5GHz) Radiation Patterns.....	92

# Figures

---

Figure 1: Front Panel of the TQ6702e GEN2 Access Point .....	17
Figure 2: Back Panel of the TQ6702e GEN2 Access Point .....	17
Figure 3: Ethernet LAN Port .....	19
Figure 4: LEDs .....	20
Figure 5: Reset Button .....	21
Figure 6: TQ0301 Dual-band Patch Antenna and 2m RF Cables .....	23
Figure 7: TQ0301 Ports .....	24
Figure 8: TQ0064 10m RF Extension Cable .....	24
Figure 9: Ground Posts .....	32
Figure 10: Connecting the Ground Wire to the Access Point .....	32
Figure 11: Removing the Cap from the LAN Port .....	34
Figure 12: Sealing Nut, Clamping Claw, and Sealing Insert .....	35
Figure 13: Sliding the Ethernet LAN Cable Through the Sealing Nut and Clamping Claw .....	35
Figure 14: Installing the Sealing Insert .....	36
Figure 15: Inserting the Sealing Insert in the Clamping Clamp .....	36
Figure 16: Connecting the LAN Cable to the Ethernet LAN Port .....	37
Figure 17: Tightening the Sealing Nut .....	37
Figure 18: Attaching a Surge Protector to an Antenna Connector .....	38
Figure 19: Screwing the Nut onto the Surge Protector .....	38
Figure 20: Installing the Metal and Rubber Washers on the Surge Protector .....	39
Figure 21: Installing an Antenna on a Surge Protector .....	39
Figure 22: Tightening the Nut to Secure the Antenna .....	40
Figure 23: Installing the Antennas to the Access Point .....	40
Figure 24: Orientations of the Mounting Base to the Access Point .....	41
Figure 25: Correct Orientation .....	42
Figure 26: Invalid Orientations of the Access Point .....	43
Figure 27: Marking the Mounting Base Holes on the Wall .....	45
Figure 28: Attaching the Mounting Base to the Access Point .....	46
Figure 29: Attaching the Access Point to the Wall .....	47
Figure 30: Two Methods of Pole Installations .....	48
Figure 31: Pole Orientations for the Access Point .....	49
Figure 32: Attaching the Pole-Mount Bracket to the Pole .....	52
Figure 33: Attaching the Access Point to the Pole-Mount Brackets .....	53
Figure 34: Threading the Pole Straps .....	55
Figure 35: Wrapping the Pole Straps Around the Pole .....	56
Figure 36: Inserting the Strap Ends into the Screws .....	57
Figure 37: Tightening the Straps .....	58
Figure 38: Login Window .....	60
Figure 39: Basic Settings for Radio1 .....	61
Figure 40: Basic Settings for Radio1 .....	62
Figure 41: TQ0301 Patch Antenna on a Pole .....	68
Figure 42: Attaching the Cables to the Antenna Connectors .....	69
Figure 43: TQ6702e GEN2 Access Point and TQ0301 Patch Antenna .....	70
Figure 44: Cables and Antenna Connectors on the TQ6702e GEN2 Access Point .....	71
Figure 45: Attaching the cable to an Antenna Connector .....	72
Figure 46: Pin Layout for the RJ45 Connector on the LAN Port .....	79
Figure 47: Antenna Locations and Axes .....	91
Figure 48: 2.4/5GHz Dual (2.4GHz) Radiation Patterns .....	91
Figure 49: 2.4/5GHz Dual (5GHz) Radiation Patterns .....	92
Figure 50: 5GHz Single (5GHz) Radiation Patterns .....	92

# Tables

---

Table 1. Components of the Access Point .....	18
Table 2. LEDs .....	21
Table 3. Components in the TQ6702e Access Point Shipping Boxes .....	28
Table 4. Pole Sizes and Angles .....	49
Table 5. Components in the TQ0301 Patch Antenna Shipping Boxes .....	65
Table 6. Component in the TQ0064 Extension Cable Shipping Boxes .....	67
Table 7. TQ6702e GEN2 Physical Specifications .....	74
Table 8. Environmental Specifications .....	74
Table 9. TQ6702e GEN2 Maximum Power Consumption .....	74
Table 10. Antenna Specifications .....	75
Table 11. Frequency and Gain .....	75
Table 12. TQ0301 Antenna Physical Specifications .....	76
Table 13. TQ0301 Antenna Environmental Specifications .....	76
Table 14. TQ0301 Antenna Product Specifications .....	76
Table 15. TQ0301 Power Input .....	77
Table 16. Cable Physical Specifications .....	78
Table 17. Cable Environmental Specifications .....	78
Table 18. Cable Product Specifications .....	78
Table 19. Cable Power Handling .....	78
Table 20. LAN Port Specifications .....	79
Table 21. MDI Pin Signals (100Base-TX) .....	79
Table 22. MDI-X Pin Signals (100Base-TX) .....	79
Table 23. 1000Base-T Connector Pinouts .....	80
Table 24. Operation Frequency .....	81

# Preface

---

This guide contains the hardware installation instructions for the following products:

- ❑ TQ6702e GEN2 Outdoor Wireless Access Point
- ❑ TQ6702e GEN2-R Outdoor Wireless Access Point
- ❑ TQ0301 Dual-band Patch Antenna
- ❑ TQ0064 RF Extension Cable

This preface contains the following sections:

- ❑ “Safety Symbols Used in this Document” on page 9
- ❑ “Translated Safety Statements” on page 10
- ❑ “Professional Installation Instructions” on page 11
- ❑ “Contacting Allied Telesis” on page 12

## Safety Symbols Used in this Document

---

This document uses the following conventions.

---

**Note**

Notes provide additional information.

---



---

**Caution**

Cautions inform you that performing or omitting a specific action may result in equipment damage or loss of data.

---



---

**Warning**

Warnings inform you that performing or omitting a specific action may result in bodily injury.

---

## Translated Safety Statements

---

**Important:** Safety statements that have the  symbol are translated into multiple languages in the *Translated Safety Statements* document at [www.alliedtelesis.com/library](http://www.alliedtelesis.com/library).

**Remarque:** Les consignes de sécurité portant le symbole  sont traduites dans plusieurs langues dans le document *Translated Safety Statements*, disponible à l'adresse [www.alliedtelesis.com/library](http://www.alliedtelesis.com/library).

## Professional Installation Instructions

---

You must comply with the following cautions:

Installation personnel

This product is designed for specific applications and needs to be installed by a qualified individual who has RF and related rule knowledge. The general user shall not attempt to install the product or modify the settings.

Installation location

The product shall be installed at a location where the radiating antenna can be kept 20cm from nearby persons in normal operation conditions to meet regulatory RF exposure requirements.

## **Contacting Allied Telesis**

---

If you need assistance with this product, visit the Allied Telesis web site at **[www.alliedtelesis.com/support](http://www.alliedtelesis.com/support)**.

## Chapter 1

# Product Description

---

This chapter describes the hardware components of the TQ6702e GEN2 access points and optional antenna and cables. This chapter contains the following sections:

- ❑ “Features of the TQ6702e GEN2 Access Points” on page 14
- ❑ “Management Tools” on page 16
- ❑ “TQ6702e GEN2 Access Points” on page 17
- ❑ “TQ0301 Patch Antenna and TQ0064 RF Extension Cable” on page 23

## Features of the TQ6702e GEN2 Access Points

---

The TQ6702e GEN2 Wireless Access Point is a dual-radio access point with 4x4 (2.4GHz) and 8x8 (5GHz) Wi-Fi 6 wireless connectivity. This access point is suitable for both indoor and outdoor environments. With the PoE++ LAN port, the access point can be connected to your wired network and powered from a PoE++ power source device.

Basic hardware features include:

- One 2.4GHz radio
- One 5GHz radio
- Four 2.4G/5GHz dual-band antennas
- Four 5GHz external antennas
- One 100M/1000M/2.5G/5G Base-T Ethernet LAN port
- Power over Ethernet (PoE++) on the LAN port
- One Reset button for restoring the default settings
- LEDs for LAN, WLAN, and power
- Pole or wall installation
- External antenna surge protectors
- N-type antenna connectors for replacing antennas
- Aluminum chassis to repel ultraviolet (UV) radiation and withstand high temperature (IP66/IP67 protection rating)

Basic features of the 2.4G and 5GHz radios include:

- IEEE 802.11a/b/g/n/ac/ax
- Channel blankets
- Multi-channel, single channel, and hybrid operation
- Automatic channel selection
- Band steering
- WiFi multimedia (WMM) for prioritizing traffic

Basic features of the Ethernet LAN port include:

- 100Mbps (IEEE 802.3u), 1000Mbps (IEEE 802.3ab), 2.5Gbps, and 5Gbps (IEEE 802.3bz)
- PoE++ (IEEE 802.3bt)
- Flow control (IEEE 802.3x)
- VLAN tagging (IEEE 802.1Q)

- Auto-Negotiation for speed and duplex mode
- Auto MDI-MDIX

Basic software features include:

- Zero Wait DFS
- Flow control (IEEE 802.3x)
- VLAN tagging (IEEE 802.1Q)
- Link aggregation
- Cascade configuration
- On-board web browser management interface
- Virtual access point (VAP)
- Network Time Protocol (NTP) client
- Dynamic Host Control Protocol (DHCP) client
- Static WEP, WPA Personal, and WPA Enterprise security
- Static WEP encryption: 64/128 bit (IEEE802.11a/b/g)
- WPA and WPA2 encryption: CCMP (AES) and TKIP
- WPA3 encryption CCMP (AES/CNSA)
- Quality of Service (QoS) ingress and egress queues
- Fast roaming (IEEE802.11v/k/r)
- Captive portals
- MAC address client filtering with the on-board filter
- MAC address client filtering with RADIUS servers
- Wireless Distribution System (WDS) bridges
- Quick Response codes for VAPs
- System log
- Syslog client
- SNMPv1, v2c, and v3
- Orthogonal Frequency Division Multiple Access (OFDMA)

Optional antenna and cables:

- TQ0301 dual-band patch antenna
- TQ0064 RF extension cable

## Management Tools

---

The access point supports the following management tools.

### **Web Browser**

The access point has a web browser management interface for configuring the device from your management workstation. The web browser interface allows you to manage one unit at a time and supports both non-secure HTTP and secure HTTPS management sessions. The default is HTTP. The product has been tested with Microsoft Internet Explorer version 11 or later, Microsoft Edge, and Chrome.

### **Vista Manager EX and AWC Plug-in**

The access point supports Vista Manager and the Autonomous Wave Control (AWC) plug-in. Configuring and monitoring large numbers of devices is simplified with AWC because you can add multiple devices to management groups and manage them as one unit. The application can also monitor the operations of the access points and automatically adjust operating properties to optimize the performance of your wireless network.

---

**Note**

The Channel Blanket feature requires Vista Manager EX and the AWC plug-in.

---

### **SNMPv1 and v2c**

You can use SNMPv1 or SNMPv2 to view the parameter settings of the device. The MIB is available from the Allied Telesis web site. For instructions on how to configure the unit for SNMP, refer to Allied Telesis *TQ6000 GEN2 Wireless Access Points Management Software User's Guide*.

---

**Note**

The access point does not support SNMPv3 or the AT-UWC Wireless LAN Controller.

---

# TQ6702e GEN2 Access Points

The front panel components of the access point are illustrated in Figure 1.

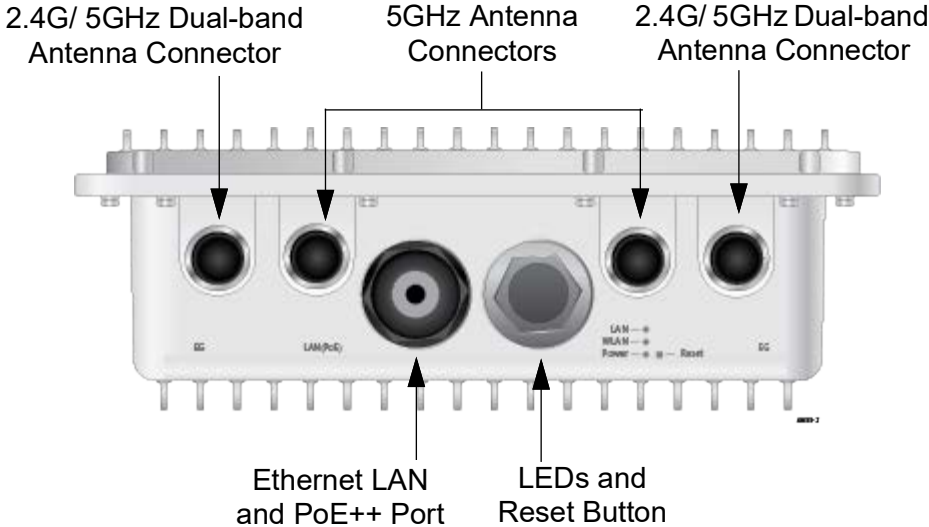

Figure 1. Front Panel of the TQ6702e GEN2 Access Point

The back panel components are illustrated in Figure 2.

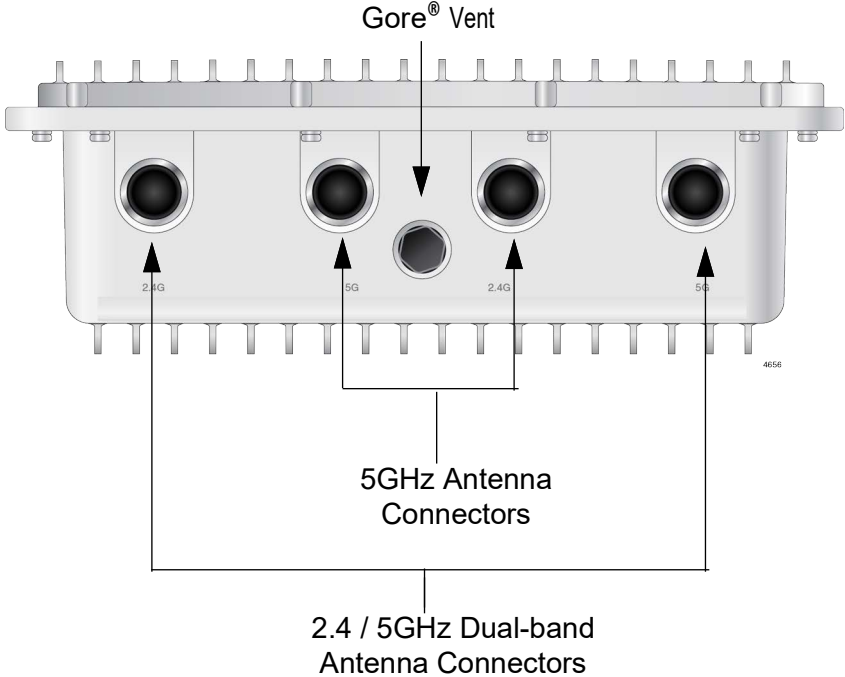

Figure 2. Back Panel of the TQ6702e GEN2 Access Point

The components are listed in Table 1.

Table 1. Components of the Access Point

Component	Description
Four 5GHz Antenna Connectors	N-type female connectors for the 5GHz antennas
Four 2.4G/5GHz Antenna Connectors	N-type female connectors for the 2.4G/5GHz dual-band antennas
LAN Port (PoE++ Input)	The LAN port is a standard 100M/1000M/2.5G/5G Ethernet port. The port is used to connect the access point to your local area network and to provide power to the device from a PoE++ source device. The access point has to be powered by a PoE++ source device. Refer to “LAN Port” on page 18.
Three LEDs	<p>The access point has the following LEDs:</p> <ul style="list-style-type: none"> <li>❑ LAN - Displays status information about the Ethernet LAN port.</li> <li>❑ WLAN - Displays status information about the radios.</li> <li>❑ Power - Displays status information about PoE++.</li> </ul> <p>Refer to “LEDs” on page 20.</p>
Reset Button	The reset button returns the access point to its default settings. Refer to “Reset Button” on page 21.
Gore® vent	The vent equalizes housing pressures, protects against dirt, dust, humidity and water, and reduces condensation.

---

**Note**

Do not remove the Gore® vent plug from the access point.

---

## LAN Port

The TQ6702e GEN2 access point has one Ethernet LAN port on the front panel. The port has two functions. The first is to connect the wireless clients to your wired Local Area Network (LAN). The second is to receive power for the product from a PoE++ source device. The access point does not have an internal power supply and it does not support an external power adapter. It has to be powered from a PoE++ source device on this port. Refer to Figure 3 on page 19.

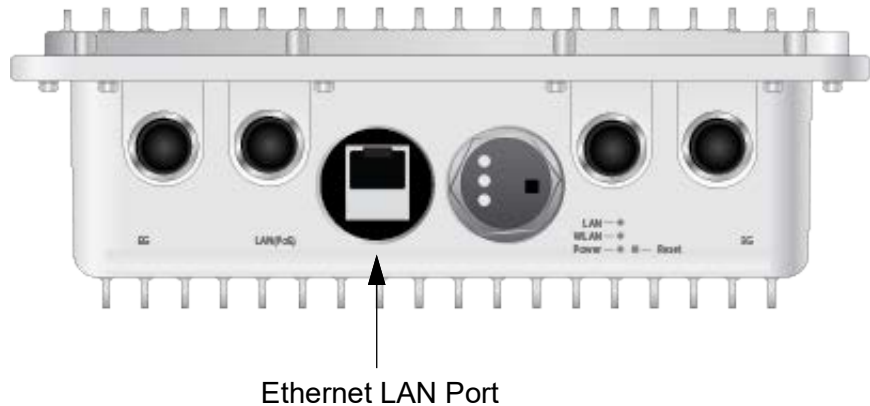

Figure 3. Ethernet LAN Port

### Power over Ethernet (PoE++)

The TQ6702e GEN2 access point supports Power over Ethernet Plus (PoE++) on the LAN port. As such, the access point receives its power from a PoE++ source device over the network cable that also carries the network traffic. The product is a PoE++ class 5 powered device with a maximum power consumption of 29.2 watts. The device does not have an internal power supply and it does not support an external AC/DC power adapter. It has to be powered by a PoE++ source device on its LAN port.

---

#### Note

The PoE++ source device that supplies power to this device, such as a switch, must be a UL listed Information Technology Equipment (ITE).

---

### Connector Type

The LAN port has an eight-pin RJ45 connector. The port uses four pins at 100 Mbps and all eight pins at 1000 Mbps and higher speeds. The pin assignments are listed in “LAN Port” on page 79.

### Speed

The LAN port can operate at 100M/1000M/2.5G/5Gbps. The speed is set automatically with Auto-Negotiation. You cannot disable Auto-Negotiation on the port.

---

#### Note

The LAN port should be connected to a network device that also adjusts its speed with Auto-Negotiation.

---

### Duplex Mode

The LAN port can operate in either half- or full-duplex mode at 100 Mbps, and full-duplex mode at 1000M/2.5G/5Gbps. The port is IEEE802.3u-compliant and uses Auto-Negotiation to set the duplex mode. You cannot disable Auto-Negotiation on the port.

**Note**

The LAN port should be connected to a network device that also sets its duplex mode with Auto-Negotiation. If the network device does not support Auto-Negotiation, the LAN port operates at half-duplex mode. This may result in a duplex mode mismatch if the network device is operating at full duplex.

**Automatic MDIX Detection**

The twisted-pair port is IEEE 802.3ab compliant and features automatic MDIX detection when operating at 100 Mbps. This feature automatically configures the port to MDI or MDI-X depending on the wiring configuration of the port on the Ethernet switch.

You may not disable automatic MDIX detection. For automatic MDIX detection to work properly, it must also be present on the Ethernet switch. The LAN port defaults to MDIX if it is connected to a network device that does not support automatic MDIX detection.

**Maximum Distance**

The LAN ports have a maximum operating distance of 100m (328 feet).

**Port Pinouts**

Refer to Table 21 on page 79 for the port pinouts of the LAN port when it is operating at 10 or 100 Mbps in the MDI configuration and Table 22 on page 79 for the MDI-X configuration. Refer to Table 23 on page 80 for the port pinouts when the port is operating at 1000 Mbps.

**LEDs**

The access point has three LEDs under the transparent cap on the front panel. Refer to Figure 4.

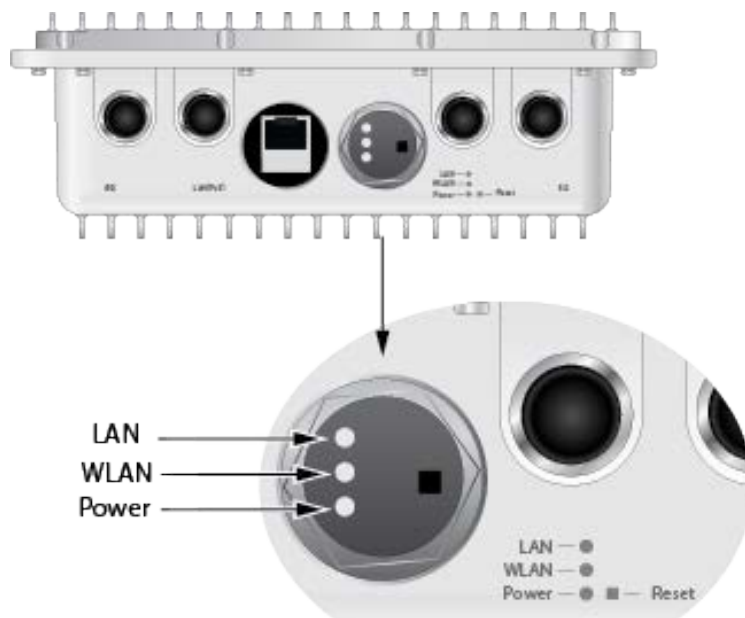

Figure 4. LEDs

The LEDs are described in Table 2.

Table 2. LEDs

LED	State	Description
LAN	Solid Green	The LAN port is receiving power from a PoE++ source device and is operating normally.
	Blinking Green	The LAN port is receiving power from a PoE++ source device and is transmitting/receiving network traffic.
	Off	The access point is powered off because the LAN port is not receiving power from a PoE++ source device.
WLAN	Solid Green	One or both radios (i.e., Radio1, Radio2, or both) are enabled.
	Off	All radios are disabled or the access point is powered off.
Power	Solid Green	The power from the PoE++ source device is within the normal operating range.
	Blinking Green	The access point is booting up or upgrading its firmware.
	Off	The access point is not receiving power from a PoE++ source device on the Ethernet LAN port,

**Reset Button**

The access point has a reset button under the transparent cap on the front panel. Refer to Figure 5.

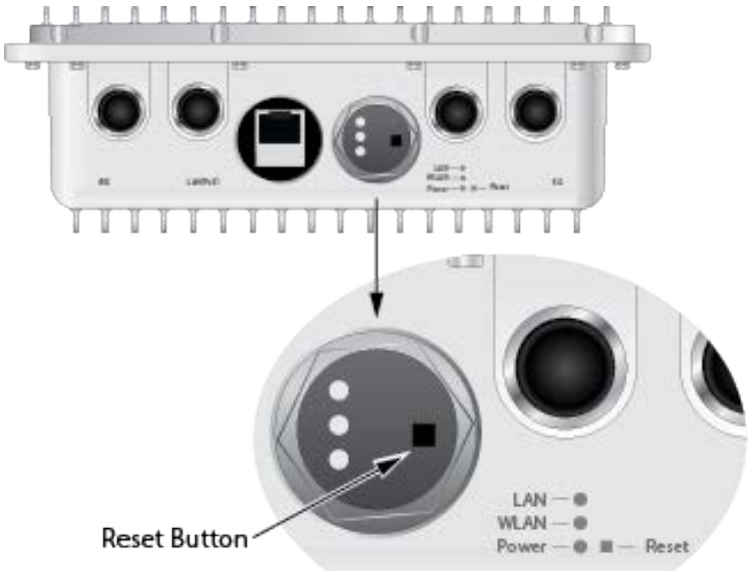

Figure 5. Reset Button

You can use the reset button to return the parameter settings of the device to their default values. You might reset the access point if you want to discard its current configuration or because you forgot the password to the manager account and so cannot manage the device.

To reset the device, remove the transparent cap on the front panel and press the black button for five seconds and release.

You can enable or disable the reset button with the management software. The default setting is disabled. If the access point is installed in a public area, you probably should leave it disabled to protect the device from being reset by unauthorized individuals.

### **Ethernet Cable Requirements**

The minimum cable requirements for the Ethernet LAN port are listed here.

- ❑ 100Mbps - Standard TIA/EIA 568-A-compliant Category 5 or TIA/EIA 568-B-compliant Category 5 unshielded cabling.
- ❑ 1000M/2.5G/5Gbps - Standard TIA/EIA 568-A-compliant Enhanced Category 5 (Cat 5e) or TIA/EIA 568-B-compliant Enhanced Category 5 (Cat 5e) unshielded cabling.

### **Maximum Distance**

The LAN port has a maximum operating distance of 100 meters (328 feet).

## TQ0301 Patch Antenna and TQ0064 RF Extension Cable

The TQ6702e GEN2 access point comes with four 2.4G/5GHz dual-band antennas and four 5GHz antennas. To extend coverage range, Allied Telesis offers the TQ0301 dual-band patch antenna with four 2 meter long cables. In addition, Allied Telesis offers the TQ0064 RF extension cable, which is 10 meter long.

The components of the TQ0301 dual-band patch antenna and 2m RF cables are illustrated in Figure 6.

TQ0301 Patch Antenna

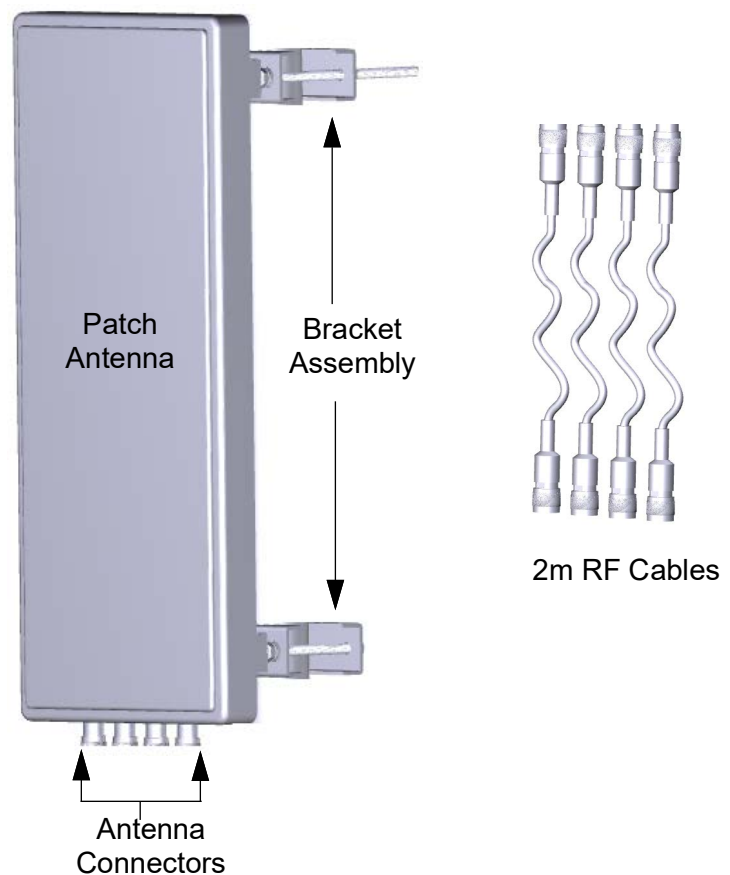

Figure 6. TQ0301 Dual-band Patch Antenna and 2m RF Cables

See Figure 7 for the port numbers on the TQ0301 patch antenna.

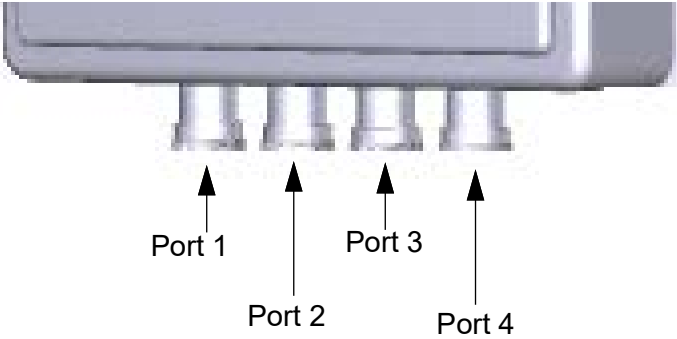

Figure 7. TQ0301 Ports

The TQ0064 10 meter RF cable is illustrated in Figure 8.

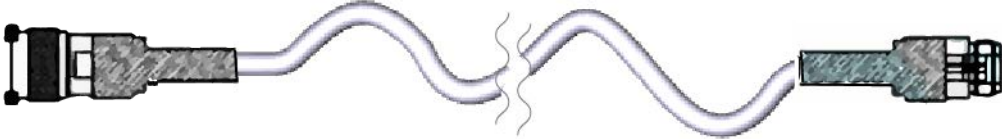

Figure 8. TQ0064 10m RF Extension Cable

## Chapter 2

# Installing the Access Point

---

This chapter contains the following installation procedures for the TQ6702e GEN2 access point:

- ❑ “Reviewing Safety Precautions” on page 26
- ❑ “Unpacking the Access Point” on page 28
- ❑ “Attaching the Ground Cable to the Access Point” on page 31
- ❑ “Connecting an Ethernet Cable to the Access Point” on page 34
- ❑ “Attaching the Antennas to the Access Point” on page 38
- ❑ “Installing the Access Point” on page 41
- ❑ “Installing the Access Point on a Wall” on page 44
- ❑ “Installing the Access Point on a Pole” on page 48
- ❑ “Installing on a Pole Using the U-Bolts and Pole-Mount Bracket” on page 51
- ❑ “Installing on a Pole Using the Pole Straps and Mounting Base” on page 54
- ❑ “Starting the First Management Session” on page 59
- ❑ “Setting the Country and Location” on page 61

---

### **Note**

The non-US model of this product has a country code setting that must be set during the initial management session of the unit. The setting ensures that the unit operates in compliance with the laws and regulations of your country or region.

For the US model, the country code is preset and cannot be changed. Per FCC regulations, the country code setting for all WiFi products marketed in the US must be fixed to US operational channels only.

---

## Reviewing Safety Precautions

---

Please review the following safety precautions before beginning the installation procedures.

---

### Note

The  indicates that a translation of the safety statement is available in a PDF document titled *Translated Safety Statements* on the Allied Telesis website at [www.alliedtelesis.com/support](http://www.alliedtelesis.com/support).

---



---

### Warning

To prevent electric shock, do not remove the cover. No user-serviceable parts inside. This unit contains hazardous voltages and should only be opened by a trained and qualified technician. To avoid the possibility of electric shock, disconnect electric power to the product before connecting or disconnecting the LAN cables.

 E1

---



---

### Warning

Do not work on equipment or cables during periods of lightning activity.  E2

---



---

### Warning

Operating Temperature. This product is designed for a maximum ambient temperature of 65°C  E50

---



---

### Caution

FCC Caution: Any changes or modifications not expressly approved by the party responsible for compliance could void the user's authority to operate this equipment.  E80

---

---

### Note

All Countries: Install product in accordance with local and National Electrical Codes.  E8

---

---

**Note**

You should verify that your PoE network adheres to the standards of a separated extra-low voltage (SELV) circuit before using the PoE feature on the wireless access point.

---



---

**Warning**

Only trained and qualified personnel are allowed to install or to replace this equipment. ⚡ E14

---



---

**Warning**

This equipment shall be installed in a Restricted Access location. ⚡ E45

---



---

**Warning**

**Hot Surface, Do Not Touch!** - The finned surface on the back of the chassis is a heat sink and can become dangerously hot when the unit is operating. ⚡ E114

---

## Unpacking the Access Point

To unpack the access point, perform the following procedure:

1. Remove all components from the shipping boxes.

---

**Note**

Store the packaging material in a safe location. You must use the original shipping material if you need to return the unit to Allied Telesis.

---

2. Verify that all components listed in Table 3 are included in your shipping boxes.

Table 3. Components in the TQ6702e Access Point Shipping Boxes



Name	Component
Four 5GHz single band antennas	 <p>The image shows four identical antennas arranged horizontally. Each antenna is a long, thin, cylindrical rod with a curved top edge. At the bottom, there is a mounting bracket with a circular base and a small notch. The text '5G' is printed on the base of each antenna.</p>
Four 2.4G/5GHz dual band antennas	 <p>The image shows four identical antennas arranged horizontally. Each antenna is a long, thin, cylindrical rod with a curved top edge. At the bottom, there is a mounting bracket with a circular base and a small notch. The text '5G' is printed on the base of each antenna.</p>

Table 3. Components in the TQ6702e Access Point Shipping Boxes (Continued)







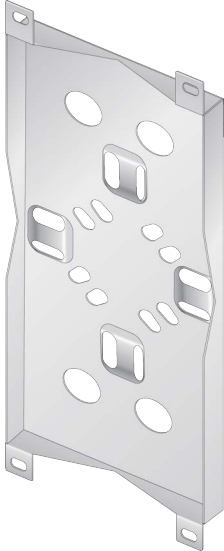

Name	Component
One Mounting Base	
Four sets of a screw (M6xP1.0 16mm), washer, and spring washer for attaching the mounting base to the access point	
One pole-mount bracket	
Four sets of Hex-head bolts, washers, and spring Washers for attaching the access point to the pole-mount bracket	

Table 3. Components in the TQ6702e Access Point Shipping Boxes (Continued)

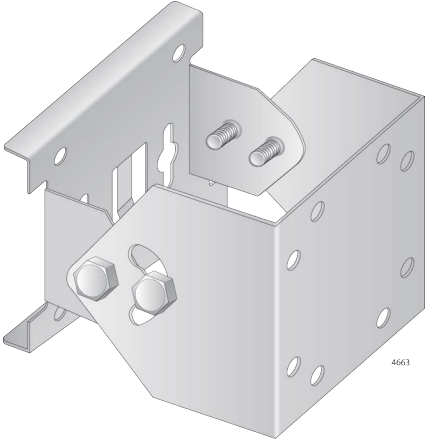
Name	Component
Two U-bolts	
Four nuts for the U-bolts	
Two pole straps	
One 8AWG ground cable	
One screw with washer and spring washer for the ground cable	
<p>Eight external surge protectors with nuts and metal and rubber washers</p> <p><b>Note</b> The ground lug on the surge protector is <i>not</i> used.</p>	

- If any item is missing or damaged, contact your Allied Telesis sales representative for assistance.

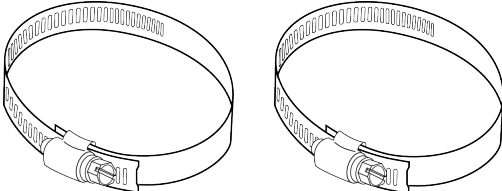
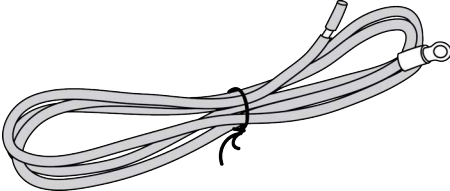
## Attaching the Ground Cable to the Access Point

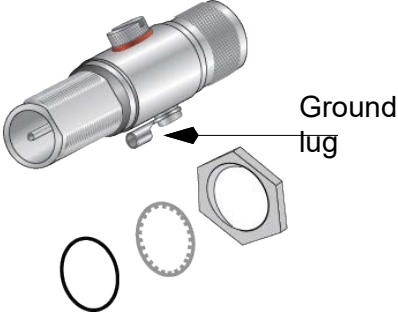
---

The ground cable protects the device from damage from lightning strikes or electrostatic discharge (ESD).

### Guidelines to Attaching the Ground Cable

Review the following guidelines before attaching the ground cable to the access point:

- Attach the ground cable to the access point before installing the mounting base.
- Connect the ground cable directly to the earth ground.
- Keep the ground cable as short as possible; remove any extra cable.
- Do not sharply bend, loop, or coil the ground cable.
- Connect the surge protector ground cable and the equipment ground to a single common ground. The equipment ground includes power ground and telecommunications ground.
- The recommended earth ground impedance is less than 1.0 ohm.
- Measure the ground impedance at the point where the surge protector ground cable, not at the ground rod.
- If you provide your own ground cable, use a 10 AWG or larger stranded wire as the ground cable.

### What to Prepare for Attaching the Ground Cable

You need the following items to attach the ground cable to the access point:

- TQ6702e GEN2 Access Point
- Ground cable
- One screw for the ground cable
- Phillips-head screwdriver

---

#### Note

A Phillip-head screwdriver is not included with the product.

---

### Attaching the Ground Cable to the Access Point

To attach the ground cable to the access point, perform the following procedure:

1. Place the access point upside-down on a table or desk.
2. Select a ground post on the access point for the ground wire.

The access point has two ground posts on the bottom panel. You can use either post. Refer to Figure 9 on page 32.



Figure 9. Ground Posts

3. Insert the screw through the ground lug on the ground wire and secure the wire to the selected ground post on the access point, using a Phillips-head screwdriver. Refer to Figure 10.



Figure 10. Connecting the Ground Wire to the Access Point

---

**Note**

The ground wire should be 20AWG or larger and the screw should be 3.5mm or larger.

---

4. Attach the other end of the ground wire to a circuit breaker, ground rod, or earth ground.

---

**Note**

Keep the ground cable as short as possible; remove any extra cable.

---

## Connecting an Ethernet Cable to the Access Point

---

To connect an Ethernet cable to the access point, perform the following procedure:

1. Place the access point right-side up on a table or desk.
2. Unscrew the cap on the LAN port and remove it from the access point. See Figure 11.



Figure 11. Removing the Cap from the LAN Port

3. Disassemble the sealing nut, clamping claw, and sealing insert. Refer to Figure 12.

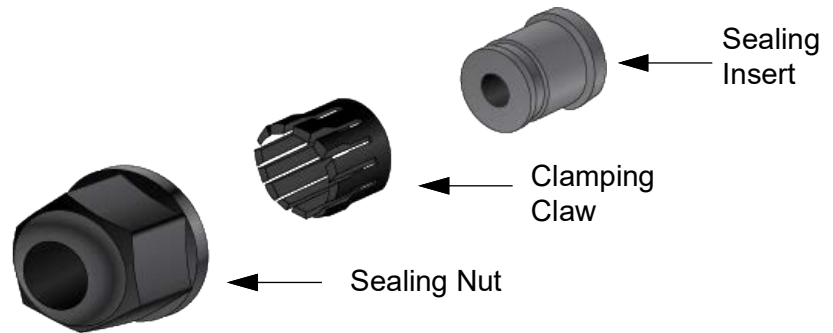

Figure 12. Sealing Nut, Clamping Claw, and Sealing Insert

4. Slide the Ethernet LAN cable through the sealing nut and clamping claw. See Figure 13. The fingers on the clamping claw need to be pointing towards the sealing nut.

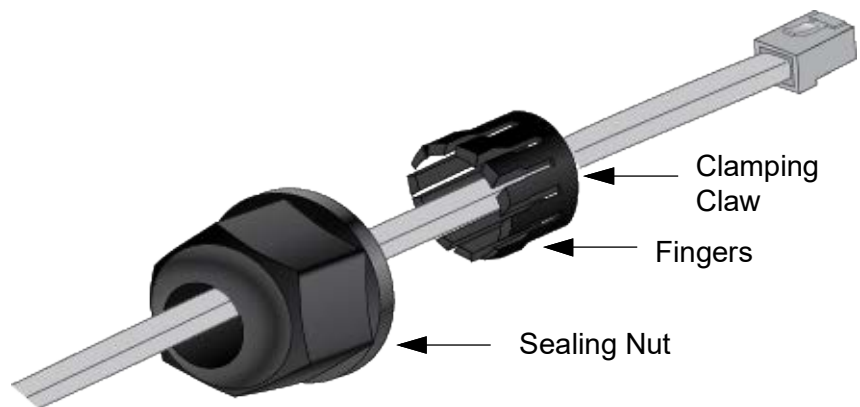

Figure 13. Sliding the Ethernet LAN Cable Through the Sealing Nut and Clamping Claw

5. Open the sealing insert and slip it onto the Ethernet wire. The end with the groove needs to be towards the clamping claw. Refer to Table 14 on page 36.

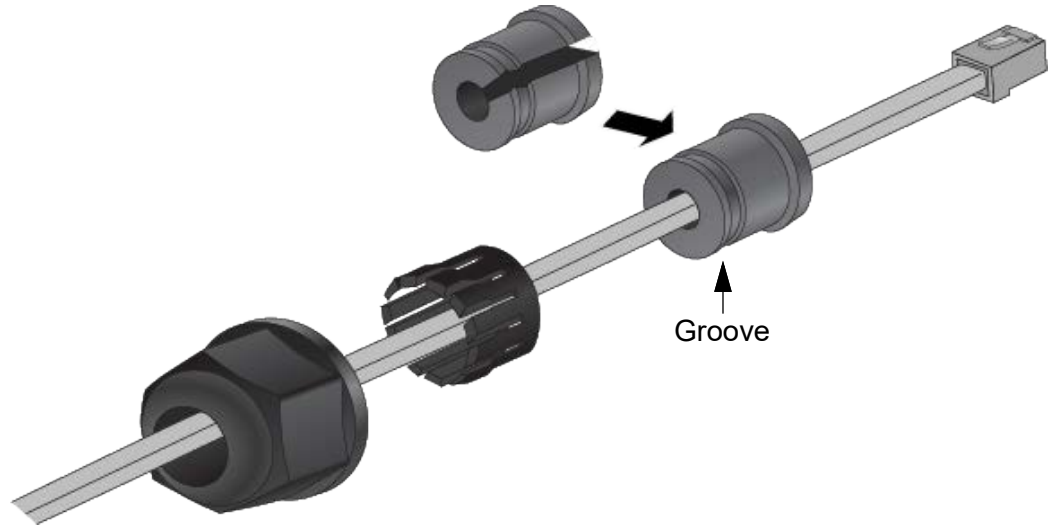

Figure 14. Installing the Sealing Insert

6. Slide the sealing insert into the clawing clamp. Refer to Figure 15.

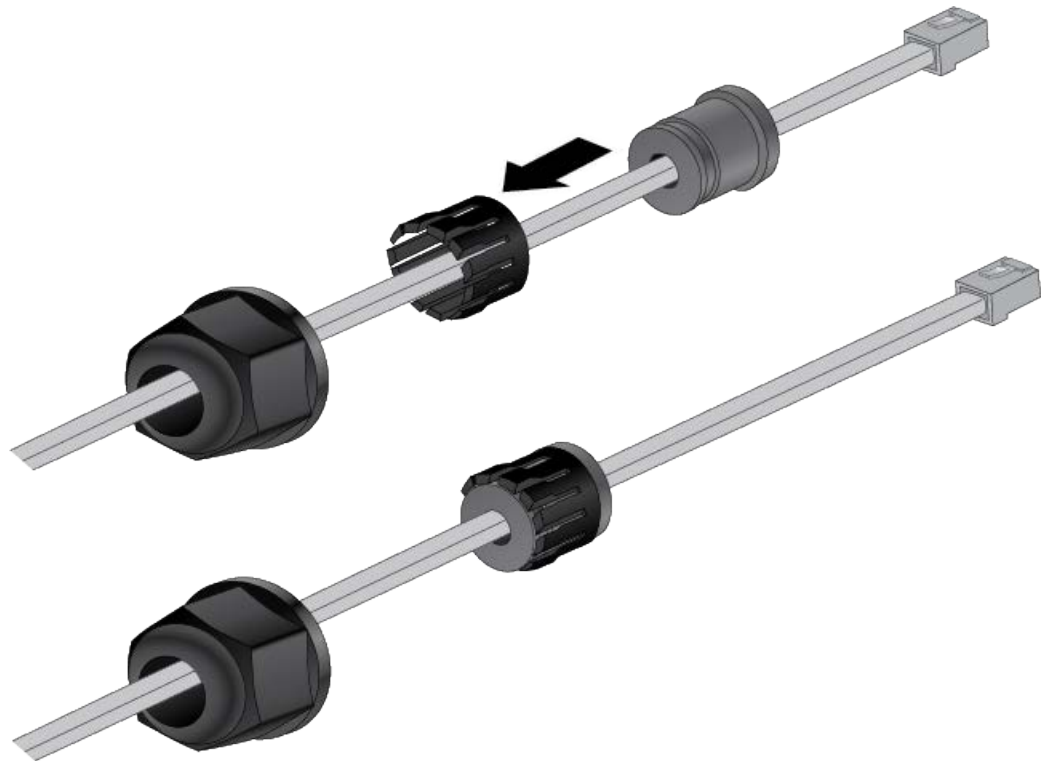

Figure 15. Inserting the Sealing Insert in the Clawing Clamp

7. Connect the RJ-45 connector on the Ethernet cable into the Ethernet LAN port inside the sealing assembly. Refer to Figure 16 on page 37.



Figure 16. Connecting the LAN Cable to the Ethernet LAN Port

8. Tighten the sealing nut on the access point. Refer to Figure 17.



Figure 17. Tightening the Sealing Nut

---

**Note**

The next step powers on the access point by attaching the Ethernet cable to a port on a PoE++ source device. Allied Telesis recommends not performing the step until you have completed all of the installation procedures.

---

9. Connect the other end of the Ethernet cable to a port on a PoE++ source device, such as a PoE++ switch.

## Attaching the Antennas to the Access Point

To install the antennas, perform the following procedure:

---

**Note**

You must install 5GHz antennas to 5GHz antenna connectors and 2.4GHz antennas to 2.4GHz antenna connectors.

---

1. Remove the blind caps covering the antenna connectors.
2. Screw a surge protector to an antenna connector. See Figure 18.



Figure 18. Attaching a Surge Protector to an Antenna Connector

3. Screw the nut onto the surge protector. Refer to Figure 19.

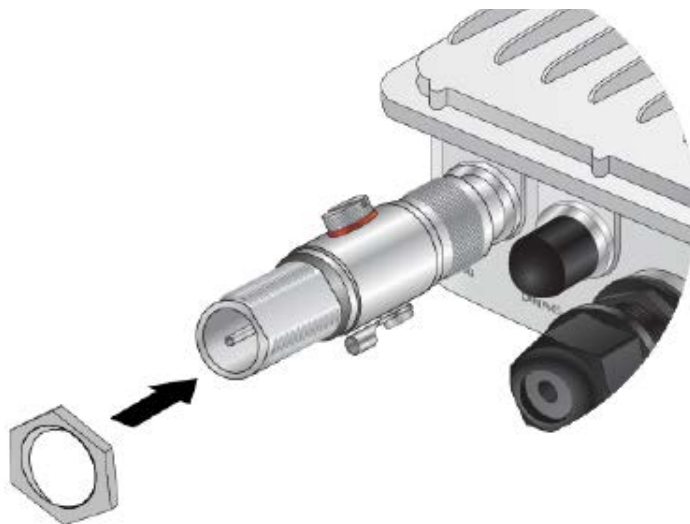

Figure 19. Screwing the Nut onto the Surge Protector

4. Install the metal and rubber washers, in that order, on the surge protector.

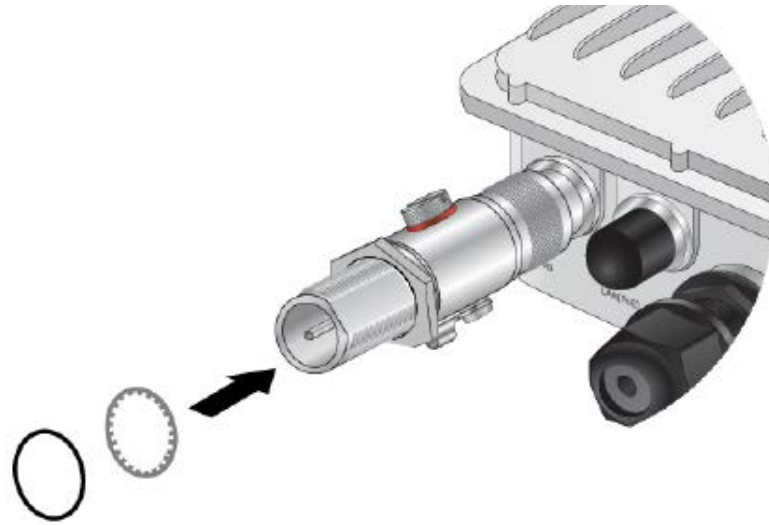

Figure 20. Installing the Metal and Rubber Washers on the Surge Protector

5. Screw an antenna onto the surge protector. Refer to Figure 21.

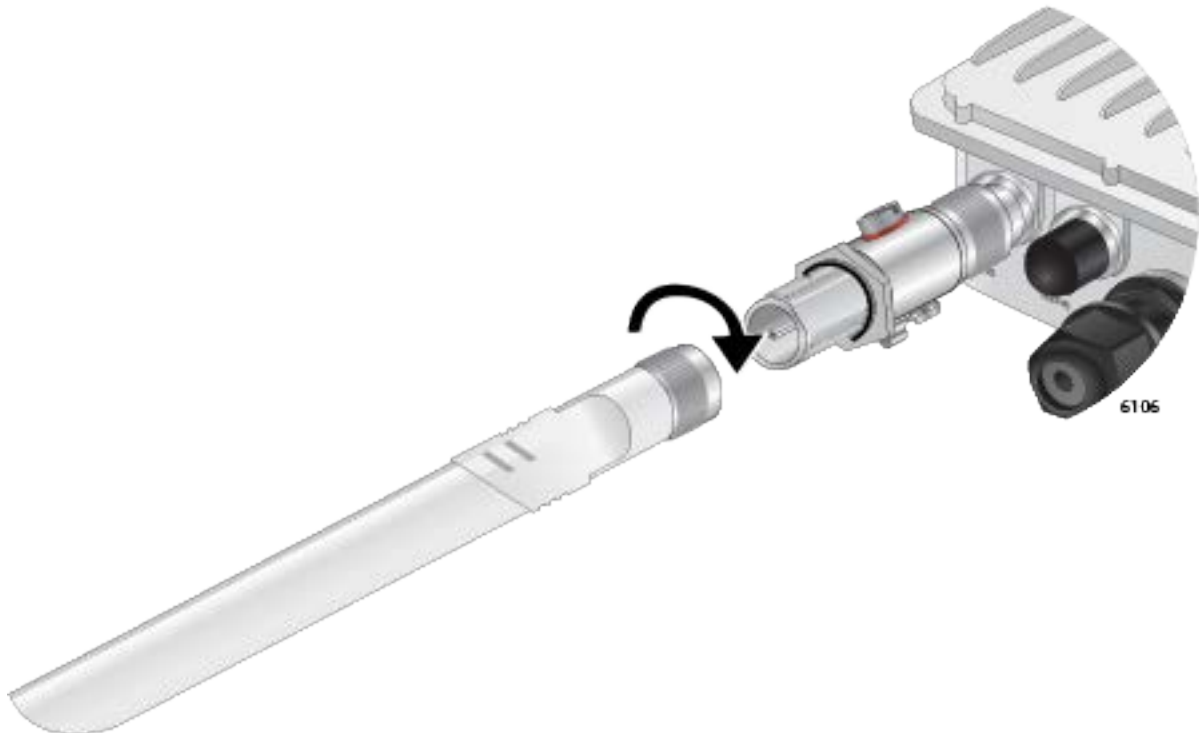

Figure 21. Installing an Antenna on a Surge Protector

6. Tighten the nut against the antenna to secure the antenna. Refer to Figure 22.

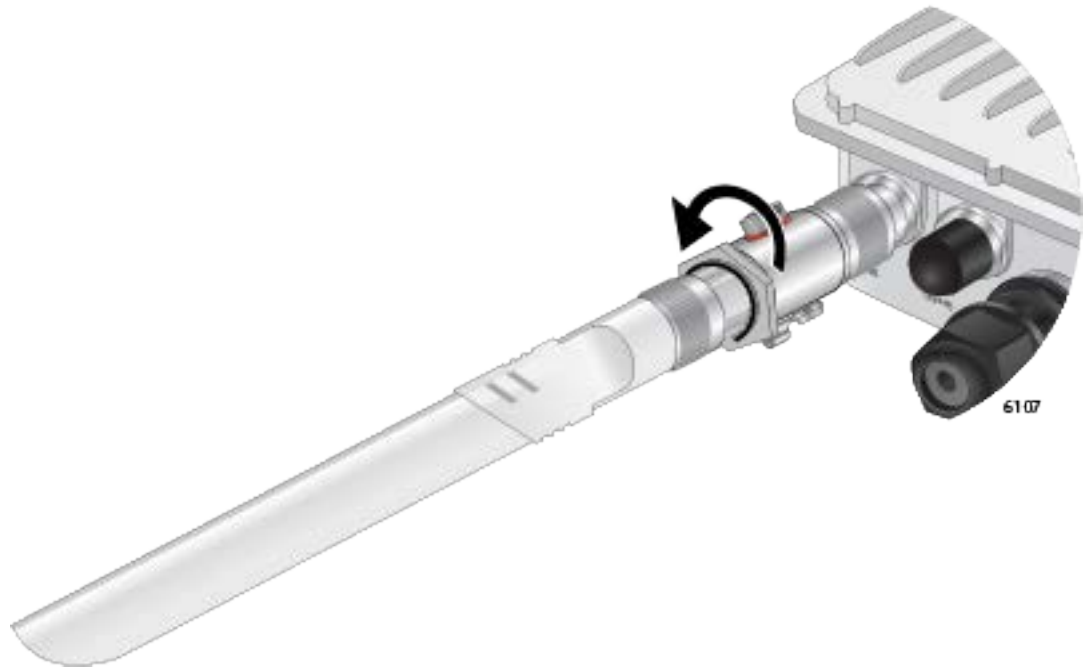

Figure 22. Tightening the Nut to Secure the Antenna

7. Repeat this procedure to install the remaining antennas. See Figure 23.

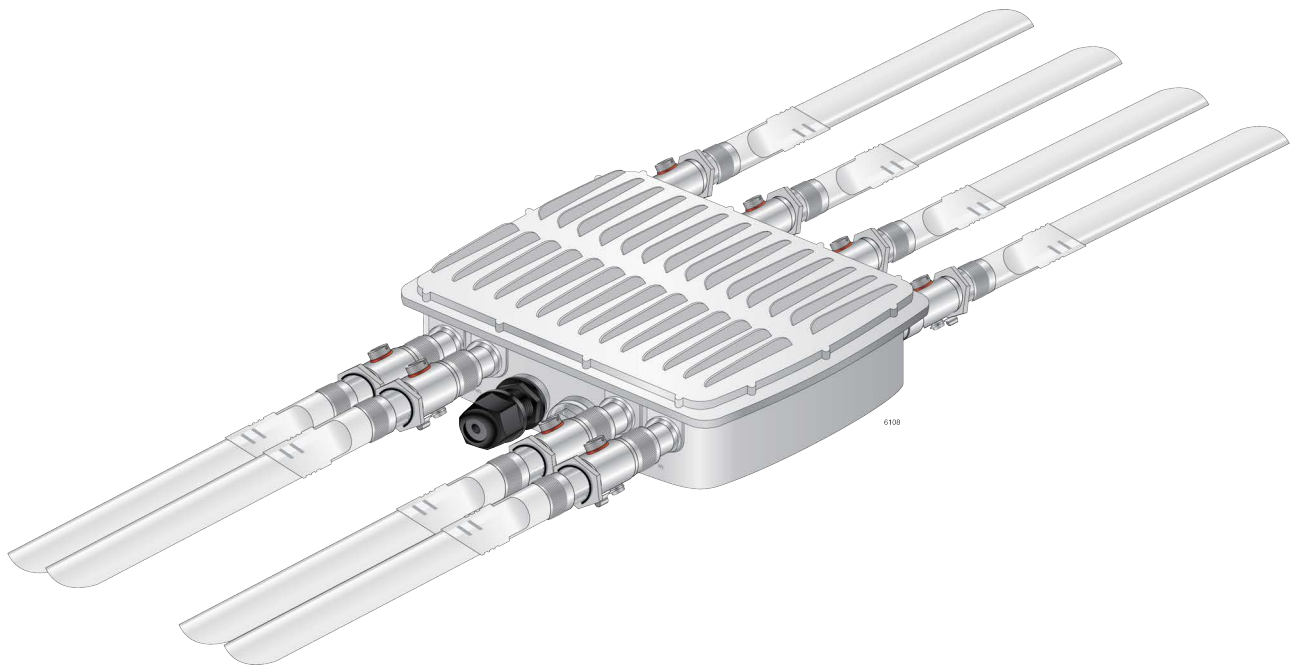

Figure 23. Installing the Antennas to the Access Point

## Installing the Access Point

The access point can be installed on a desktop, ceiling, wall or pole.

### Guidelines to Installing the Access Point on a Fixture

Review the following guidelines before installing the access point on a fixture:

- ❑ Attach the ground cable to the access point before attaching the mounting base.
- ❑ Connect the Ethernet cable to the access point before installing the access point on a wall or pole because connecting the Ethernet cable is difficult after the access point is installed.
- ❑ Attach the antennas to the access point before installing it on a wall or pole because attaching the antennas is difficult after the access point is installed.
- ❑ The mounting base can be installed in a vertical or horizontal position. See Figure 24.



Figure 24. Orientations of the Mounting Base to the Access Point

- The access point can be installed on a pole or wall with the front panel facing down. See Figure 25. The front panel is the panel with the LAN port, as shown in Figure 1 on page 17.



Figure 25. Correct Orientation

- ❑ The access point must not be installed in the orientations shown in Figure 26.

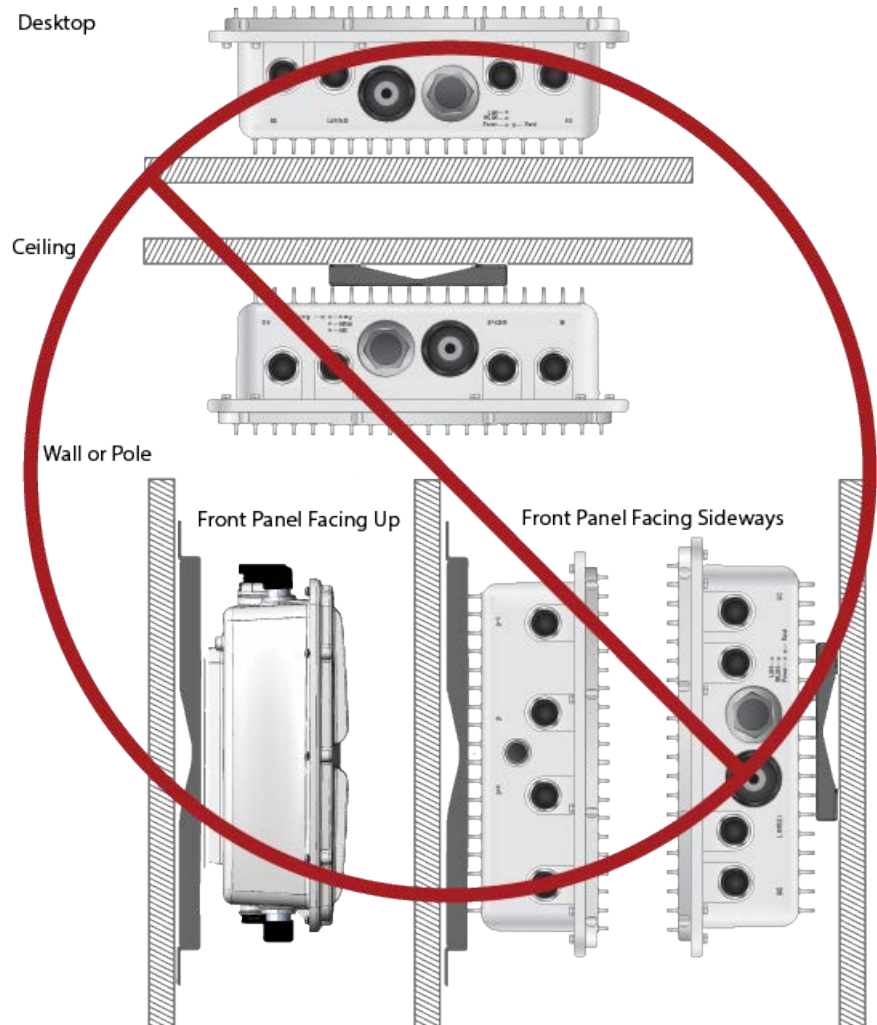

Figure 26. Invalid Orientations of the Access Point

## Installation Instructions

The following sections contain the installation instructions. Review the “Guidelines to Installing the Access Point on a Fixture” on page 41 before installing the access point:

- ❑ “Installing the Access Point on a Wall” on page 44
- ❑ “Installing the Access Point on a Pole” on page 48

## Installing the Access Point on a Wall

---

This section contains the procedures for installing the TQ6702e GEN2 access point on a wall.

### What to Prepare for Wall Installation

You need the following items to install the access point on a wall:

- TQ6702e GEN2 Access Point
- Mounting base
- Four screws for the mounting base
- Screws for the wall, one of the following:
  - Four sets of the bolt, nut, washer, and wall anchor for a concrete wall
  - Four tapping screws for a regular wall
- Drill
- Phillips-head screwdriver
- Pencil

---

**Note**

Screws for the wall, drill, Phillip-head screwdriver, and pencil are *not* included with the product.

---

### Installing the Access Point on a Wall

To install the access point on the wall, perform the following procedure:

1. Review “Guidelines to Installing the Access Point on a Fixture” on page 41.
2. Hold the mounting base on the wall at the desired location for the access point and mark the four mounting base holes with a pencil. See Figure 27 on page 45.

---

**Note**

The mounting base can be in a vertical or horizontal position. see Figure 24 on page 41.

---

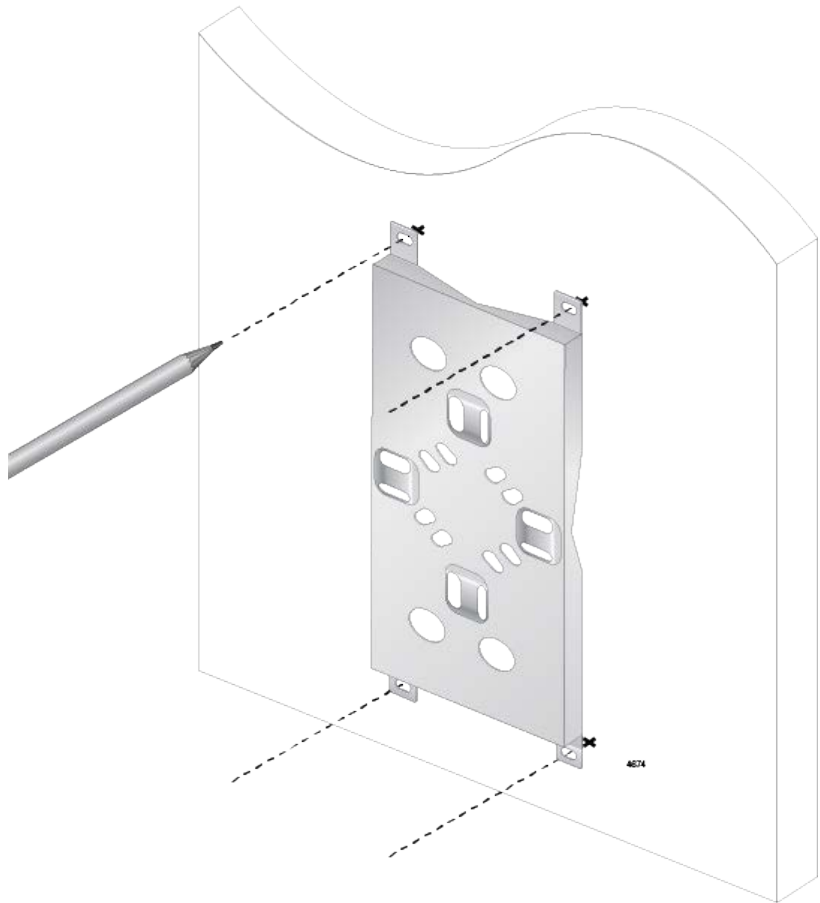

Figure 27. Marking the Mounting Base Holes on the Wall

3. Pre-drill the marked locations on the wall.
4. Install the provided wall anchors in the holes.
5. Place the access point upside-down on a table or desk.
6. Attach the mounting base to the bottom of the access point with the provided screws, spring washers, and washers, using a Phillips-head screwdriver. See Figure 28 on page 46.

---

**Note**

Attach the ground cable to the access point before attaching the mounting base. See “Attaching the Ground Cable to the Access Point” on page 31.

---



Figure 28. Attaching the Mounting Base to the Access Point

7. Attach the access point to the wall with the provided screws, using a Phillips-head screwdriver. See Figure 29 on page 47.

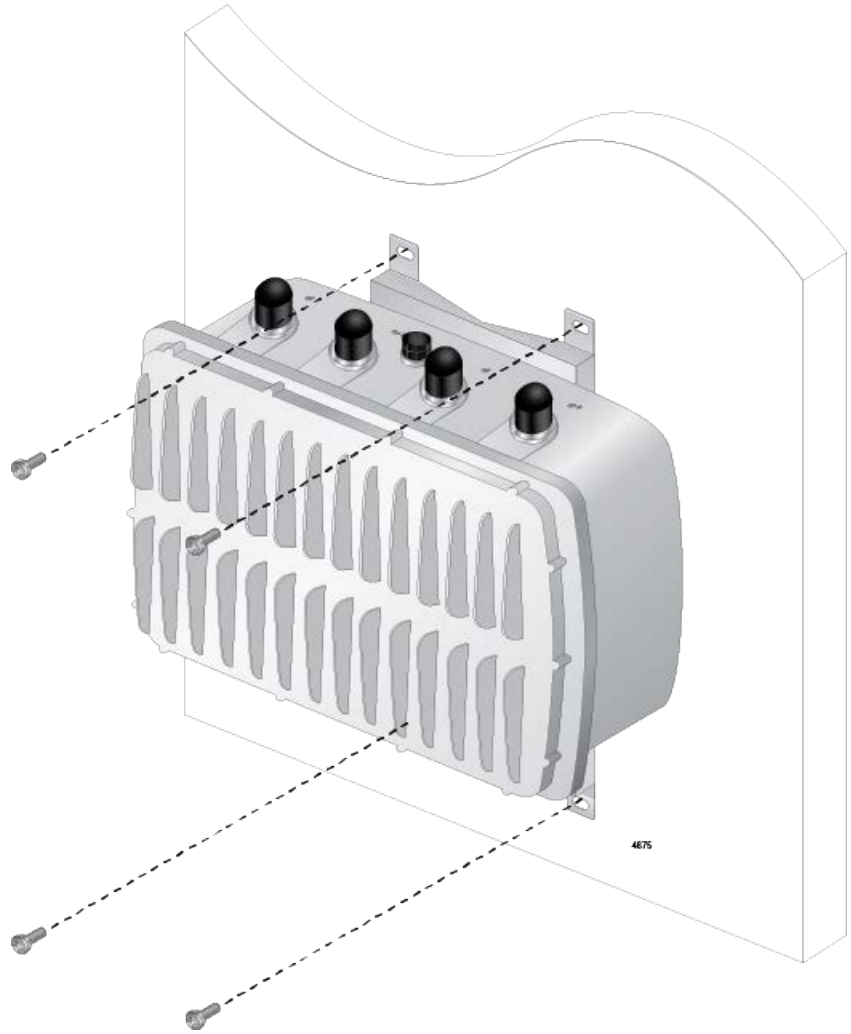

Figure 29. Attaching the Access Point to the Wall

## Installing the Access Point on a Pole

The TQ6702e GEN2 access point can be mounted on a pole using the U-bolts and pole-mount bracket or the pole straps and mounting base. See Figure 30.

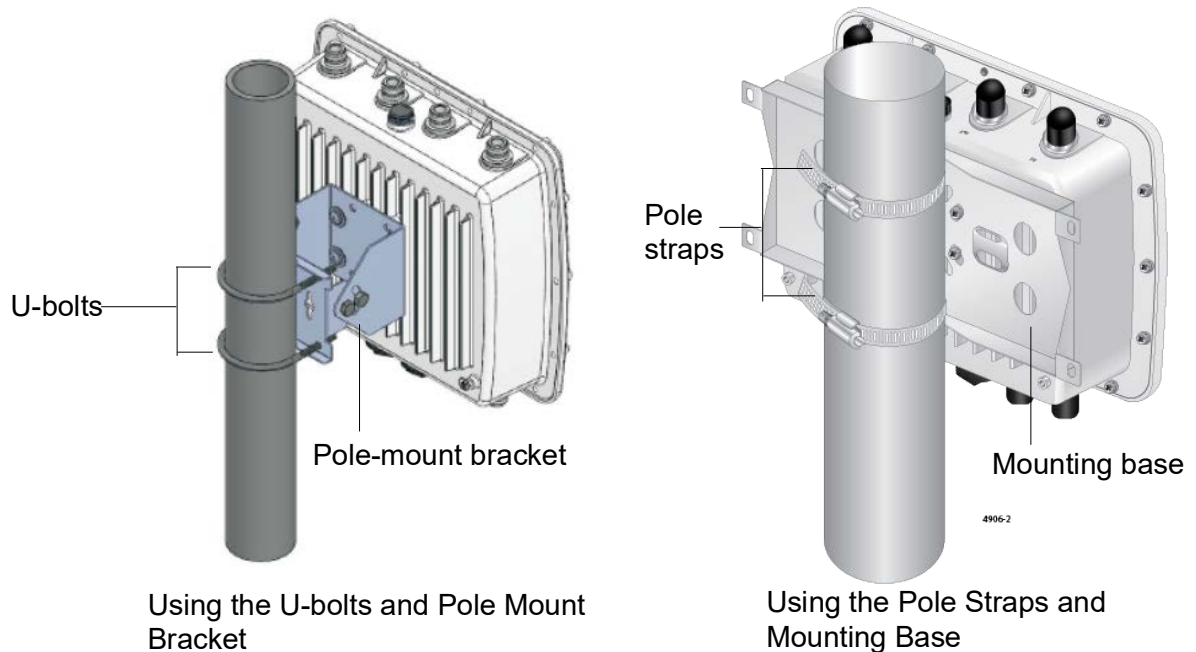

Figure 30. Two Methods of Pole Installations

Perform one of the following instructions to install the access point on a pole:

- “Installing on a Pole Using the U-Bolts and Pole-Mount Bracket” on page 51
- “Installing on a Pole Using the Pole Straps and Mounting Base” on page 54

### Two Methods to Install the Access Point on a Pole

You can install the access point on a pole using either:

- U-bolts and pole-mount bracket
- Pole straps and mounting base

The size of the pole that you are installing the access point on determines which method of the pole installation you need. Table 4 on page 49 shows the pole diameter that the U-bolts and pole straps can hold.

Table 4. Pole Sizes and Angles

Method	Pole Diameter Range	Angle Adjustable
U-bolts with Pole-mount Bracket	Φ35mm to 55mm	Yes
Pole Straps with Mounting Base	Φ80mm to 100mm	No

Another difference among two methods is whether the angle of the access point is adjustable. With the U-bolts and pole-mount bracket, you can adjust the angle of the access point upwards or downwards. With the pole straps and mounting base, you *cannot* change the angle of the access point.

### Vertical Pole and Horizontal Pole

You can install the access point on a pole that stands vertically or runs horizontally. See Figure 31.

For the orientations of the access point, see Figure 26 on page 43.



Figure 31. Pole Orientations for the Access Point

#### Note

Figure 31 shows the pole orientations using the pole straps and mounting base as examples. You can also install the access point on a vertical or horizontal pole using the U-bolts and pole-mount bracket.

## **Guidelines for Pole Installation**

Review the following guidelines before installing the access point on a pole:

- ❑ The U-bolts can hold the pole whose diameter is from 35mm to 55mm.
- ❑ The pole straps can hold the pole whose diameter is from 80mm to 100mm.
- ❑ The pole-mount bracket has two hex-head bolts that allow you to adjust the angle of the access point upwards or downwards.
- ❑ The access point can be installed on a pole that stands vertically or runs horizontally using either the U-bolts and pole-mount bracket or the pole straps and mounting base. See Figure 31 on page 49.

## Installing on a Pole Using the U-Bolts and Pole-Mount Bracket

---

To use the pole mount bracket to install the access point, the pole diameter must be from 35mm to 55mm.

---

### Note

For pole installation using the pole straps, see “Installing on a Pole Using the Pole Straps and Mounting Base” on page 54.

---

### What to Prepare for Pole Installation Using the U-Bolts and Pole-Mount Bracket

You need the following items to install the access point on a pole using the U-bolts and pole mount bracket:

- TQ6702e GEN2 access point
- Pole mount bracket
- Four sets of screws, spring washers, and washers for the pole mount bracket
- Two U-bolts
- Phillips-head screwdriver

---

### Note

A Phillip-head screwdriver is *not* included with the product.

---

### Installing the Access Point on a Pole Using the U-Bolts and Pole-Mount Bracket

To install the access point on a pole using the U-bolts and pole mount bracket, perform the following procedure:

1. Review “Guidelines for Pole Installation” on page 50.
2. Attach the pole mount brackets to the pole with the two U-bolts. See Figure 32 on page 52.

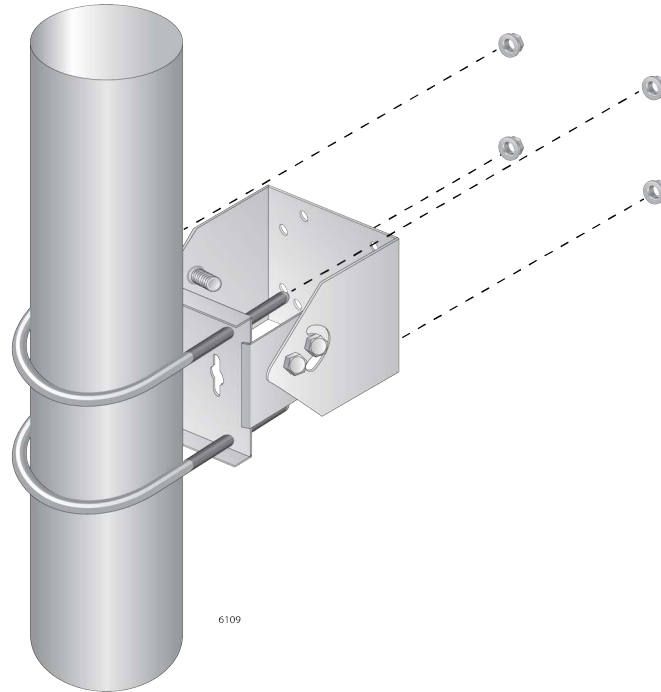

Figure 32. Attaching the Pole-Mount Bracket to the Pole

3. Attach the access point to the pole-mount bracket with the screws using a Phillips-head screwdriver. See Figure 33 on page 53.

---

**Note**

Figure 32 shows how to attach the pole mount bracket to a vertical pole as an example. You can also install the bracket to a horizontal pole.

---

---

**Note**

Attach the ground cable to the access point before attaching the mounting base to the access point. Refer to “Attaching the Ground Cable to the Access Point” on page 31.

---

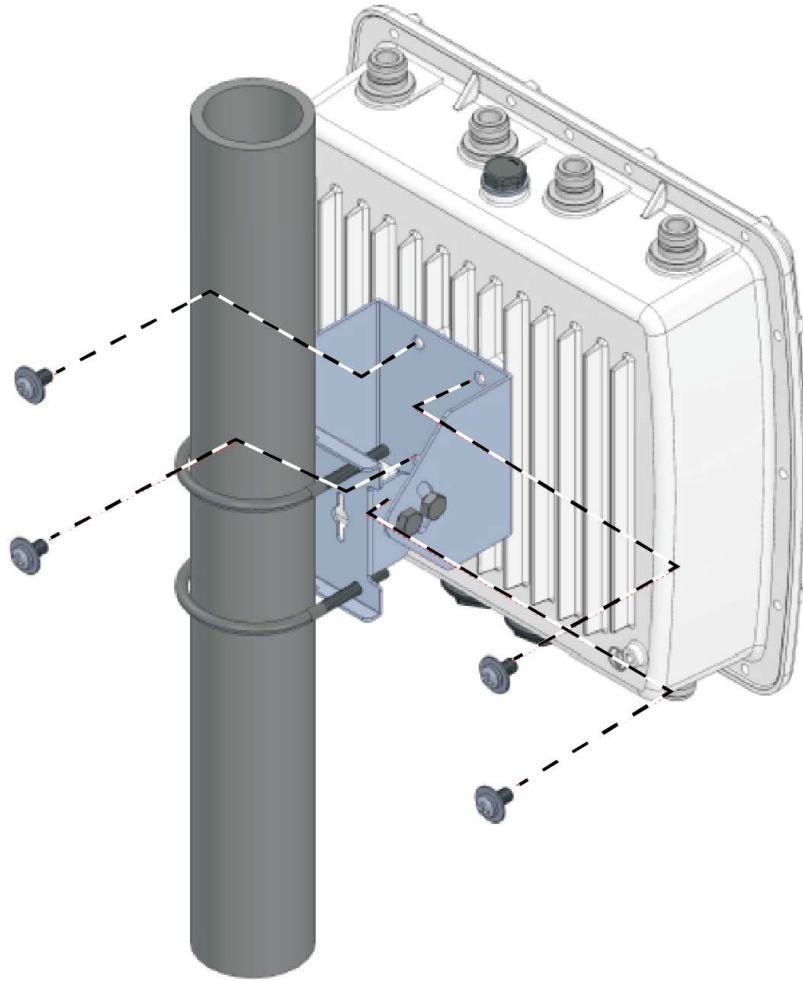

Figure 33. Attaching the Access Point to the Pole-Mount Brackets

### **Adjusting the Position Upwards or Downwards**

To adjust the angle of the access point upwards or downwards, perform the following procedure:

1. Loosen the two bolts located on the sides of the pole mount brackets using an adjustable wrench or a 10mm socket and ratchet.
2. Adjust the angle of the access point upward or downward.
3. Tighten the bolts.

## Installing on a Pole Using the Pole Straps and Mounting Base

---

To use the pole straps and mounting base to install the access point, the pole diameter must be from 80mm to 100mm.

---

### Note

For the pole installation using the U-bolts and pole-mount bracket, see “Installing on a Pole Using the U-Bolts and Pole-Mount Bracket” on page 51.

---

### What to Prepare for Pole Installation Using the Pole Straps and Mounting Base

You need the following items to install the access point on a pole using the pole straps and mounting base:

- TQ6702e GEN2 access point
- Mounting base
- Two Pole straps
- Four sets of screws, spring washers, and washers for the mounting base
- Phillips-head screwdriver

---

### Note

A Phillip-head screwdriver is *not* included with the product.

---

### Installing the Access Point on a Pole Using the Pole Straps and Mounting Base

To install the access point on a pole using the pole straps and mounting base, perform the following procedure:

1. Review “Guidelines for Pole Installation” on page 50.
2. Attach the mounting base to the bottom of the access point with the provided screws, spring washers, and washers, using a Phillips-head screwdriver. See Figure 28 on page 46.

---

### Note

Attach the ground cable to the access point before attaching the mounting base. See “Attaching the Ground Cable to the Access Point” on page 31.

---

3. Thread one pole strap through the holes marked 1 to attach to the mounting base. Repeat to thread the other pole strap. See Figure 34.

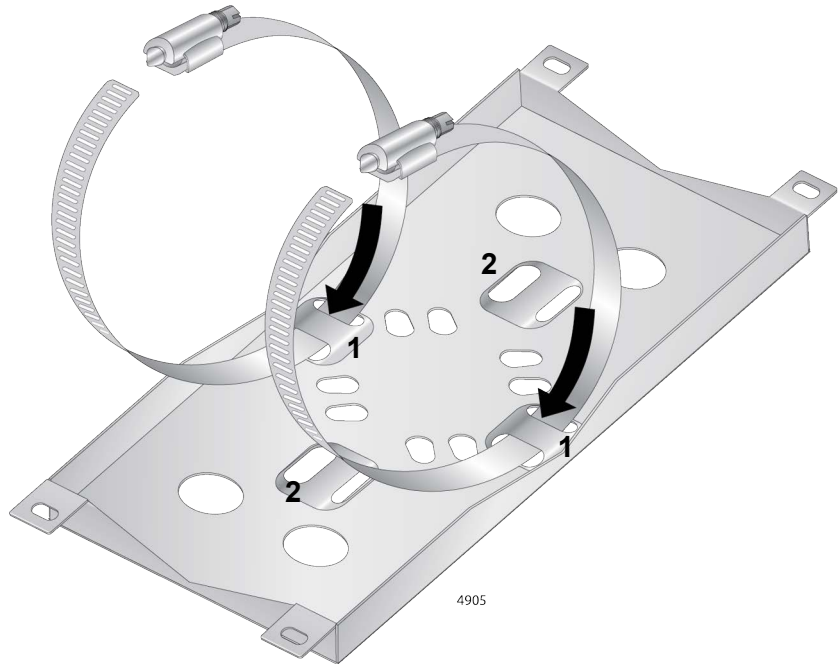

Figure 34. Threading the Pole Straps

---

**Note**

Figure 34 shows how to install the access point to a vertical pole. To install the access point on a horizontal pole, use the holes marked 2 to attach the pole straps to the mounting base.

---

4. Wrap the pole straps around the pole as shown in Figure 35.



Figure 35. Wrapping the Pole Straps Around the Pole

5. Insert the ends of the pole straps beneath the strap screws. Refer to Figure 36.



Figure 36. Inserting the Strap Ends into the Screws

6. Tighten the screws with a Phillips-head screwdriver to secure the access point to the pole. See Figure 37.



Figure 37. Tightening the Straps

## Starting the First Management Session

---

This section contains an abbreviated version of the procedure to start the first management session. For complete instructions, refer to the following documents found at [www.alliedtelesis.com/library](http://www.alliedtelesis.com/library):

- User Guide: TQ6702e GEN2 Outdoor Wi-Fi (802.11ax) Wireless Access Point
- Getting Started with the TQR Series Wireless Router
- Wireless Management for the TQR series using the Device GUI

The wireless access point firmware includes a DHCP client. The default setting for the client is enabled. When you power on the access point, it queries the subnet on the LAN port for a DHCP server. If a DHCP server responds to its query, the unit uses the IP address the server assigns to it.

If there is no DHCP server, the access point uses the default IP address:

- TQ6702e GEN2: 192.168.1.230.
- TQ6702e GEN2-R: 192.168.1.1.

---

### Note

The first management session of the access point has to be conducted through the LAN port because the default setting for the radios is off.

---

To start the management session, perform the following procedure:

1. Connect the access point to a PoE switch.

If your network has VLANs, the access point must be connected to a port on the PoE switch that belongs to the same VLAN as the port where your management PC is connected.

You may need to access the management software on the PoE switch to list the VLANs and their port assignments. For example, if the access point is connected to a port that is a member of the Sales VLAN, your management PC must be connected to a port that is also a member of that VLAN. If your network is small and does not have VLANs or routers, you may connect your management PC to any port on the PoE switch.

2. Start the web browser on your management PC.
3. Enter the IP address of the wireless access point in the URL field of the web browser. The address is one of the following:
  - If your network does not have a DHCP server, enter the default

address.

- ❑ If your network has a DHCP server, enter the IP address that the DHCP server assigned to the access point.

The login page appears. See Figure 38 on page 60.

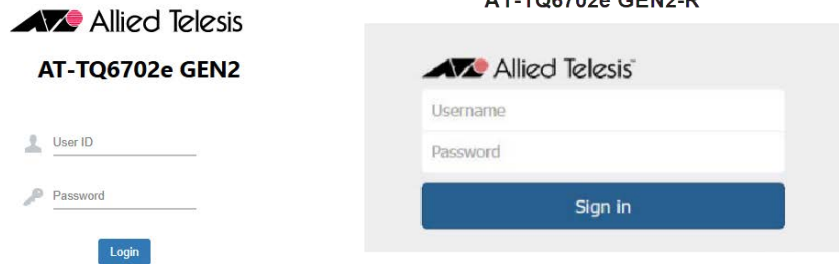

Figure 38. Login Window

4. Enter “manager” for the username and “friend” for the password.  
The username and password are case-sensitive.
5. Go to “Setting the Country and Location” on page 61.

## Setting the Country and Location

You should set the country and location during the initial management session of the access point to ensure that the device operates in compliance with the codes and regulations of your region or country.

### Note

The non-US model of this product has a country code setting that must be set during the initial management session of the unit. The setting ensures that the unit operates in compliance with the laws and regulations of your country or region.

For the US model, the country code is preset and cannot be changed. Per FCC regulations, the country code setting for all WiFi products marketed in the US must be fixed to US operational channels only.

### Setting the Country

To set the country, perform the following procedure:

1. Select Settings > Radio from the menu on the left.

The access point displays the Basic Settings for Radio 1. See Figure 39 for example.

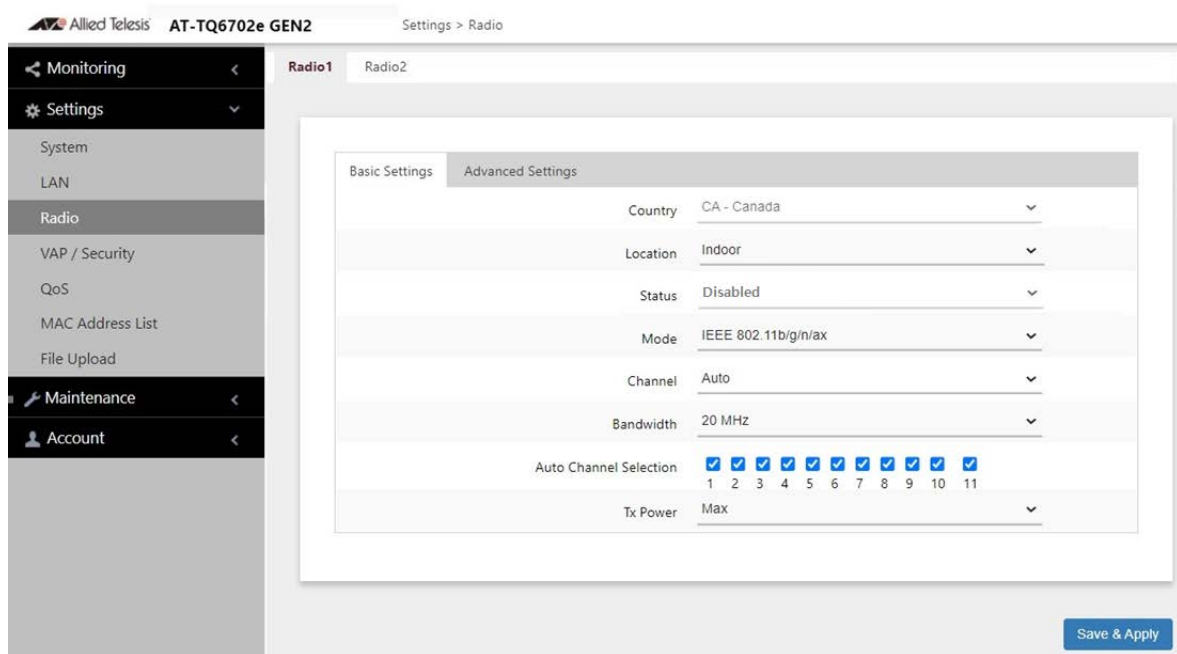

Figure 39. Basic Settings for Radio1

2. Select the Country pull-down menu and select your country or region.

---

**Note**

If the Country pull-down menu is deactivated and cannot be changed, the country parameter was set when the unit was manufactured. If the setting is not correct for your country or region, contact your Allied Telesis sales representative for assistance.

---

The access point displays a confirmation prompt.

3. Click OK to change the country setting or Cancel to cancel the procedure.

If you click OK, the access point changes the country setting and disables all radios on the access point.

---

**Note**

This procedure does not require clicking the Save & Apply button.

---

## Setting the Location

To change the location to indoor or outdoor, perform the following procedure:

1. Select Settings > Radio from the menu on the left.

The access point displays the Basic Settings for Radio 1. See Figure 39.

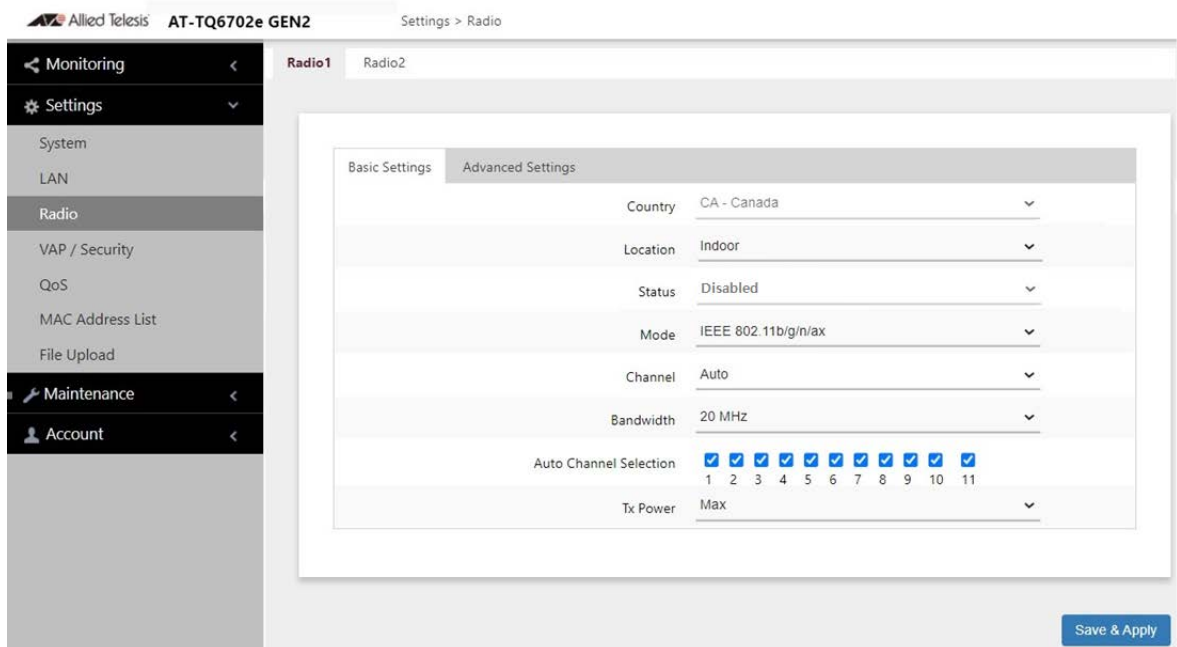

Figure 40. Basic Settings for Radio1

2. Select the Location pull-down menu and select Indoor or Outdoor.

Allied Telesis recommends rebooting the access point after changing the country and/or location setting.

## **Rebooting the Access Point**

To reboot the unit, either power off on the unit or continue with these steps:

1. Select Maintenance > Reboot from the menu on the left.
2. Click the Reboot button.
3. When the access point displays a confirmation prompt, click OK to reboot the unit or Cancel to cancel the procedure.
4. To resume managing the unit, wait for it to complete initializing its management software and then start a new management session.

---

### **Note**

For instructions on how to configure the features of the access point, see a User Guides for this access point.

---

## Chapter 3

# Installing the TQ0301 Patch Antenna and TQ0064 Extension Cable

---

The procedures in this chapter explain how to install and attach the TQ0301 dual-band patch antenna and TQ0064 extension cable to the TQ6702e GEN2 Access Point:

- ❑ “Unpacking the TQ0301 Dual-band Patch Antenna” on page 65
- ❑ “Unpacking the TQ0064 Extension Cable” on page 67
- ❑ “Installing the TQ0301 Patch Antenna on a Pole” on page 68
- ❑ “Attaching the Cables to the TQ0301 Patch Antenna” on page 69
- ❑ “Installing the TQ0301 Antenna and TQ6702e GEN2 Access Point” on page 70

## Unpacking the TQ0301 Dual-band Patch Antenna

To unpack the TQ0301 patch antenna, perform the following procedure:

1. Remove all components from the shipping boxes.

---

### Note

Store the packaging material in a safe location. You must use the original shipping material if you need to return the unit to Allied Telesis.

---

2. Verify that all components listed in Table 5 are included in your shipping boxes.

Table 5. Components in the TQ0301 Patch Antenna Shipping Boxes





Name	Component
Dual-band Patch Antenna (Bracket Assembly attached)	
Four Cables (2 m)	

Table 5. Components in the TQ0301 Patch Antenna Shipping Boxes

Name	Component
Four SMA to N jack conversion adapters	 <p data-bbox="959 470 1398 575"><b>Note</b> The adapters are not used for the TQ6702e GEN2 access point.</p>
Two metal protective caps	

3. If any item is missing or damaged, contact your Allied Telesis sales representative for assistance.

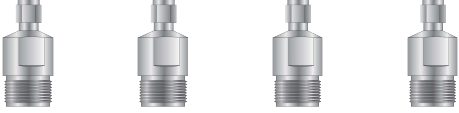
## Unpacking the TQ0064 Extension Cable

To unpack the TQ0064 extension cable, perform the following procedure:

1. Remove all components from the shipping boxes.

---

### Note

Store the packaging material in a safe location. You must use the original shipping material if you need to return the unit to Allied Telesis.

---

2. Verify that the component listed in Table 6 is included in your shipping boxes.

Table 6. Component in the TQ0064 Extension Cable Shipping Boxes

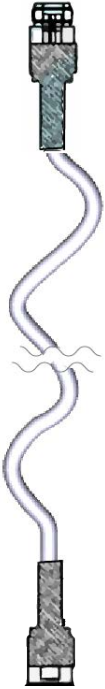
Name	Component
10 meter Cable	

3. If any item is missing or damaged, contact your Allied Telesis sales representative for assistance.

## Installing the TQ0301 Patch Antenna on a Pole

---

The TQ0301 patch antenna can be mounted on a pole with the pole-mount brackets. See Figure 41.

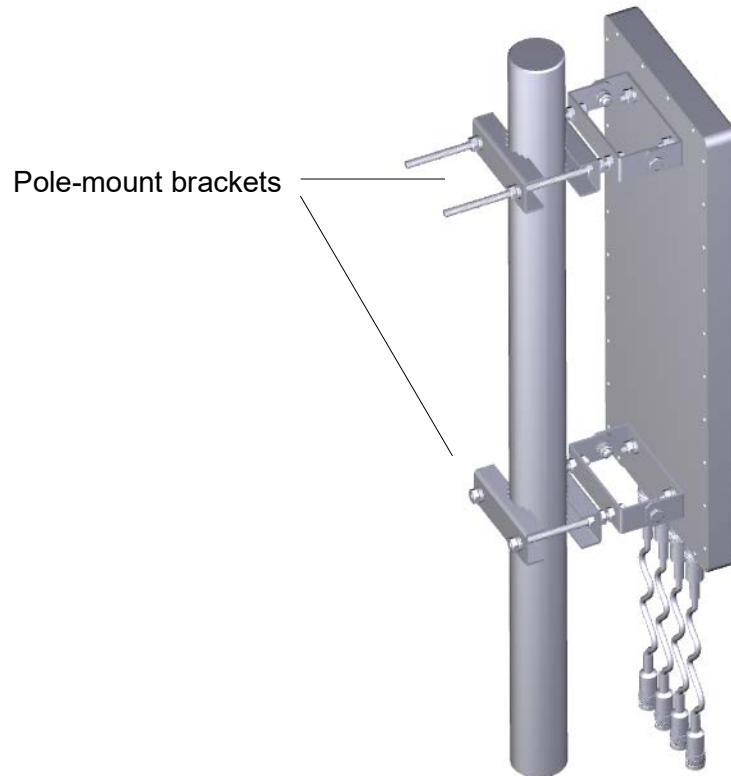

Figure 41. TQ0301 Patch Antenna on a Pole

### **Guideline for Pole Installation**

Review the following guideline before installing the access point on a pole:

- ❑ The TQ60301 patch antenna must be installed with the cable connectors facing down.
- ❑ When a cable connector is not in use, attach the metal protective cap.

## Attaching the Cables to the TQ0301 Patch Antenna

---

Allied Telesis offers two types of cables for the TQ0301 patch antenna:

- ❑ Two meter cable: comes with the TQ0301
- ❑ TQ0064 Ten meter cable

To attach the cables to the TQ0301 patch antenna, perform the following procedure:

1. Remove the connector blind caps covering the antenna connectors.
2. Attach the N-Jack adapters to the two meter cables.

---

**Note**

If you are attaching the TQ0064 10 meter cable, skip this step.

---

3. Screw the cables to the antenna connectors. See Figure 42.

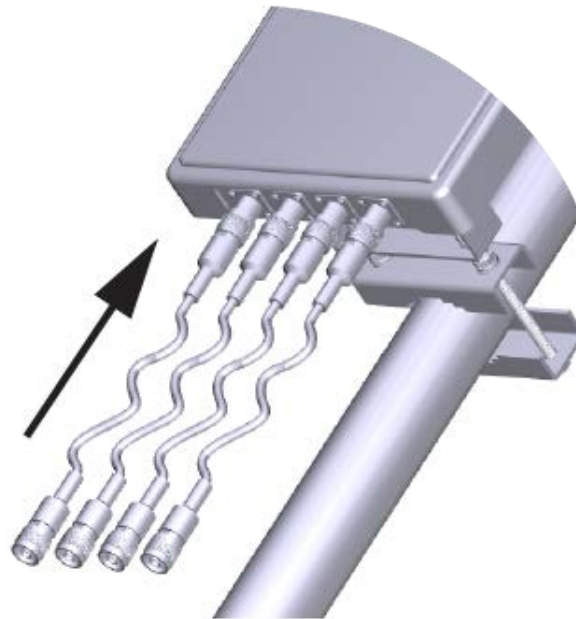

Figure 42. Attaching the Cables to the Antenna Connectors

## Installing the TQ0301 Antenna and TQ6702e GEN2 Access Point

---

The TQ0301 patch antenna should be connected to the TQ6702e GEN2 access point with the cables as shown in Figure 43.

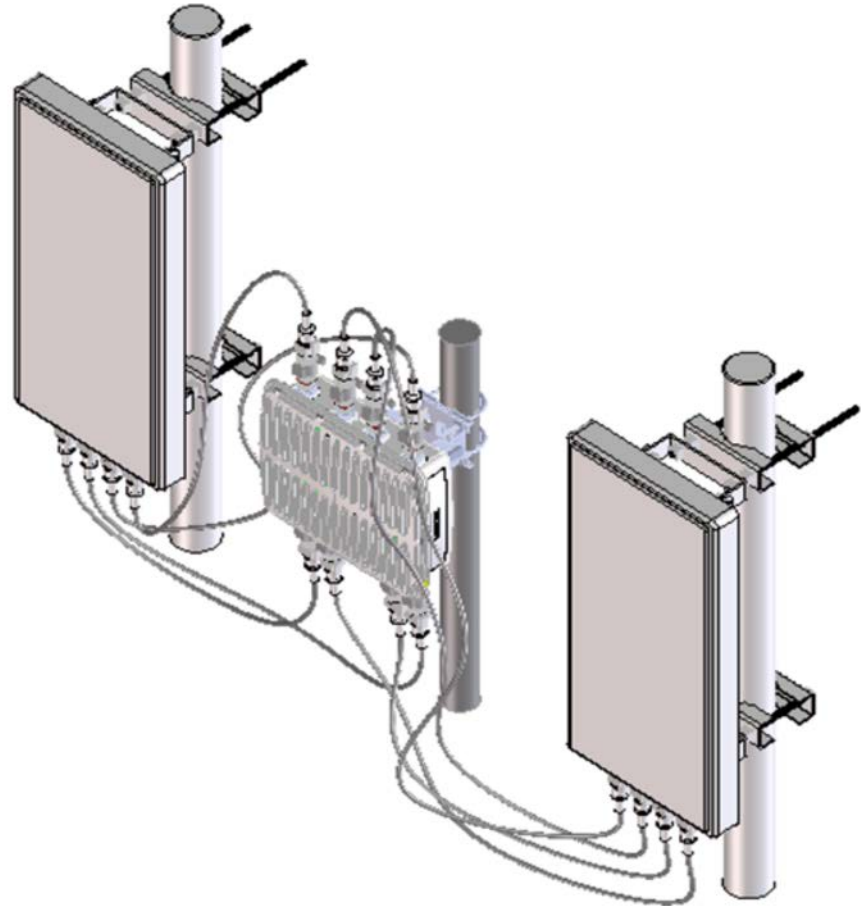

Figure 43. TQ6702e GEN2 Access Point and TQ0301 Patch Antenna

The TQ6702e GEN2 access point has two types of antenna connectors:

- ❑ 5GHz antenna connectors
- ❑ 2.4G/5GHz dual-band antenna connectors

---

**Note**

For details, see Figure 1 on page 17 and Figure 2 on page 17.

---

Figure 44 on page 71 shows cable connections to the TQ6702e GEN2 access point.

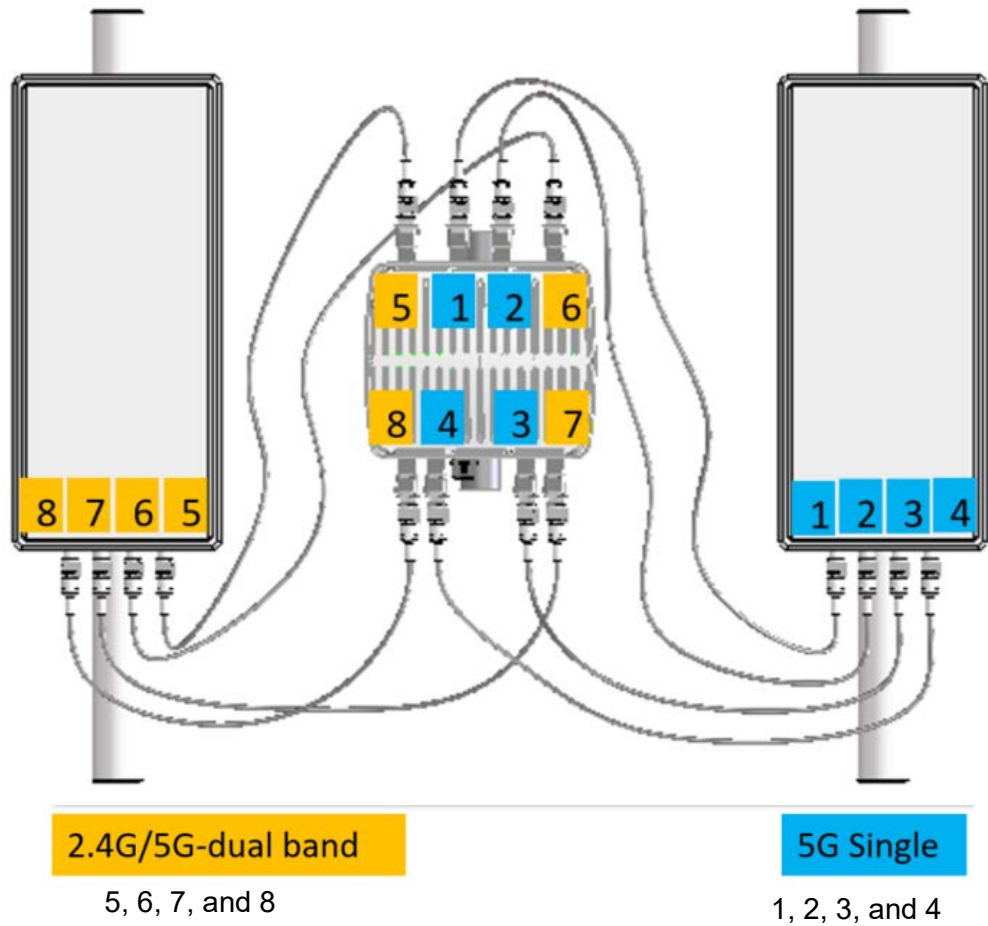

Figure 44. Cables and Antenna Connectors on the TQ6702e GEN2 Access Point

### Attaching the Cable to the TQ6702e GEN2 Access Point

To attach the cables to the TQ6702e GEN2 access point, perform the following procedure:

---

**Note**

You must install 5GHz antennas to 5GHz antenna connectors and 2.4GHz antennas to 2.4GHz antenna connectors.

---

1. Remove the connector blind caps covering the antenna connectors.
2. Screw the cable to an antenna connector. See Figure 45 on page 72.



Figure 45. Attaching the cable to an Antenna Connector

## Appendix A

# Technical Specifications

---

This appendix contains the following sections:

- ❑ “TQ6702e GEN2 Access Point Specifications”
- ❑ “TQ0301Patch Antenna Specifications” on page 76
- ❑ “TQ0064 and Cables in TQ6702e GEN2 Access Points Specifications” on page 78
- ❑ “LAN Port” on page 79
- ❑ “Operation Frequency Information” on page 81

## TQ6702e GEN2 Access Point Specifications

---

### Physical Specifications

Table 7. TQ6702e GEN2 Physical Specifications

Dimensions (W x D x H)	257 mm x 227 mm x 90 mm (10.1 in. x 8.9 in. x 3.5 in.)
Weight of the access point with default antennas and surge protectors	4.4 kg (9.7 lbs.)

### Environmental Specifications

Table 8. Environmental Specifications

Operating Temperature of the Access Point	-40° C to 65° C (-40° F to 149° F)
Storage Temperature	-40° C to 80° C (-40° F to 176° F)
Operating Humidity	5% to 95% non-condensing
Storage Humidity	UP to 95% non-condensing
Altitude of operation	Up to 3,000m (9,9843 ft)

### Power Specifications

Table 9. TQ6702e GEN2 Maximum Power Consumption

TQ6702e GEN2	29.2 watts
--------------	------------

## Antenna Specifications

This radio transmitter has been approved by Innovation, Science and Economic Development Canada to operate with the antenna types listed below, with the maximum permissible gain indicated. Antenna types not included in this list that have a gain greater than the maximum gain indicated for any type listed are strictly prohibited for use with this device.

Table 10. Antenna Specifications

Antenna type	Dipole
Antenna Connector	N-type

Table 11. Frequency and Gain

Frequency (MHz)	2400 ~ 2483.5	5150~5250	5250~5350	5470~5725	5725~5850
Gain (dBi)	3.5	6.91	6.72	6.34	7.08

## TQ0301 Patch Antenna Specifications

### Physical Specifications

Table 12. TQ0301 Antenna Physical Specifications

Dimensions (W x D x H)	550 mm x 230 mm x 40 mm (21.7 in. x 9.1 in. x 1.6 in.)
Weight of the device with antennas	3.3 kg (7.3 lb.)

### Environmental Specifications

Table 13. TQ0301 Antenna Environmental Specifications

Operating Temperature	-40° C to 70° C (-40° F to 158° F)
Storage Temperature	-40° C to 65° C (-40° F to 149° F)
Operating Humidity	5% to 95% non-condensing
Storage Humidity	UP to 95% non-condensing
Rated Wind Velocity	36.9m/s
Altitude of operation	Up to 3,000m (9,9843 ft)

### Product Specifications

Table 14. TQ0301 Antenna Product Specifications

Frequency Range	2400-2490 / 5150-5850MHz  Port 1: 2400-2490MHz & 5150-5850MHz Port 2: 2400-2490MHz & 5150-5850MHz Port 3: 2400-2490MHz & 5150-5850MHz Port 4: 2400-2490MHz & 5150-5850MHz
Peak Gain	2.4GHz: 12.5±0.5dBi / 5GHz: 15 ± 1dBi
Horizontal 3dB Beam Width	2.4GHz: 40±5° / 5GHz: 20±5°
Vertical 3dB Beam Width	2.4GHz: 40±5° / 5GHz: 20±5°
VSWR	<2
Front-to-back ratio	≥25dB
Isolation	≥22dB
Feed Impedance	50 ohms

**Power  
Specifications**

Table 15. TQ0301 Power Input

Maximum input power	50 watts
---------------------	----------

## TQ0064 and Cables in TQ6702e GEN2 Access Points Specifications

### Physical Specifications

Table 16. Cable Physical Specifications

	TQ0064	Cable in TQ6702e GEN2 / TQ6702 GEN2-R
Length	10 meter	2 meter
Weight	653g (1.4 lb.)	205g (0.45 lb.)

### Environmental Specifications

Table 17. Cable Environmental Specifications

Operating Temperature	-40° C to 80° C (-40° F to 176° F)
Operating Humidity	5% to 95% non-condensing

### Product Specifications

Table 18. Cable Product Specifications

	TQ0064	Cable in TQ6702e GEN2 / TQ6702 GEN2-R
Interface	N-plug to N-jack	N-plug to N-plug
Frequency Range	DC to 6GHz	
Peak Gain	2.4GHz: 12.5±0.5dBi / 5GHz: 15 ± 1dBi	
VSWR	<2	
Feed Impedance	50 ± 3 ohms	

### Power Specifications

Table 19. Cable Power Handling

Power Handling	50 watts
----------------	----------

## LAN Port

Table 20 shows LAN port specifications.

Table 20. LAN Port Specifications

Connector	RJ45
Standards	IEEE 802.3 (10Base-T) IEEE 802.3u (100Base-TX) IEEE 802.3ab (1000Base-T) IEEE 802.3bz (2.5GBase-T, 5GBase-T)
PoE standard	IEEE 802.3bt (Class 5)

Figure 46 illustrates the pin layout of the LAN port.

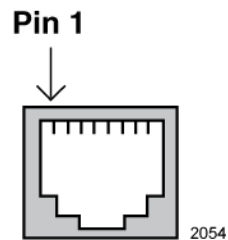

Figure 46. Pin Layout for the RJ45 Connector on the LAN Port

Table 21 lists the pin signals when the port is operating in the MDI configuration at 100 Mbps.

Table 21. MDI Pin Signals (100Base-TX)

Pin	Signal
1	TX+
2	TX-
3	RX+
6	RX-

Table 22 lists the pin signals for the MDI-X configuration at 100 Mbps.

Table 22. MDI-X Pin Signals (100Base-TX)

Pin	Signal
1	RX+
2	RX-

Table 22. MDI-X Pin Signals (100Base-TX) (Continued)

Pin	Signal
3	TX+
6	TX-

Table 23 lists the pin signals when the LAN port is operating at 1000 Mbps.

Table 23. 1000Base-T Connector Pinouts

Pin	Pair	Signal
1	1	TX and RX
2	1	TX and RX-
3	2	TX and RX+
4	3	TX and RX+
5	3	TX and RX-
6	2	TX and RX-
7	4	TX and RX+
8	4	TX and RX-

## Operation Frequency Information

---

Table 24. Operation Frequency

	2.4GHz		5150~5250GHz		5250~5350GHz		5470~5725GHz		5725~5850GHz	
	Indoor	Outdoor	Indoor	Outdoor	Indoor	Outdoor	Indoor	Outdoor	Indoor	Outdoor
CE	√	√	√	N/A	√	N/A	√	√	N/A	N/A
FCC	√	√	√	√	√	√	√	√	√	√
TELEC	√	√	√	N/A	√	N/A	√	√	N/A	N/A
RCM	√	√	√	N/A	√	N/A	√	√	√	√
IC	√	√	√	N/A	√	√	√	√	√	√

√: usable band

N/A: disabled band

## Appendix B

# Regulatory Statements

---

This appendix contains the following regulatory statements:

- ❑ “Federal Communications Commission Interference Statement” on page 83
- ❑ “Industry Canada Statement” on page 85
- ❑ “Europe - EU Declaration of Conformity” on page 87
- ❑ “UK - UKCA Declaration of Conformity” on page 88
- ❑ “European Union Restriction of the Use of Certain Hazardous Substances (RoHS) in Electrical and Electronic Equipment” on page 89

# Federal Communications Commission Interference Statement

---

## Declaration of Conformity

Manufacturer Name: Allied Telesis, Inc.

Declares that the product: **Indoor and Outdoor Wireless Access Point**

Model Number: AT-TQ6702e GEN2 and AT-TQ6702e GEN2-R

This device complies with Part 15 of the FCC Rules. Operation is subject to the following two conditions: (1) This device may not cause harmful interference, and (2) this device must accept any interference received, including interference that may cause undesired operation.

This equipment has been tested and found to comply with the limits for a Class B digital device, pursuant to Part 15 of the FCC Rules. These limits are designed to provide reasonable protection against harmful interference in a residential installation. This equipment generates, uses and can radiate radio frequency energy and, if not installed and used in accordance with the instructions, may cause harmful interference to radio communications. However, there is no guarantee that interference will not occur in a particular installation. If this equipment does cause harmful interference to radio or television reception, which can be determined by turning the equipment off and on, the user is encouraged to try to correct the interference by one of the following measures:

- Reorient or relocate the receiving antenna.
- Increase the separation between the equipment and receiver.
- Connect the equipment into an outlet on a circuit different from that to which the receiver is connected.
- Consult the dealer or an experienced radio/TV technician for help.



### Caution

FCC Caution: Any changes or modifications not expressly approved by the party responsible for compliance could void the user's authority to operate this equipment. ⚡ E80

---



### Warning

Only trained and qualified personnel are allowed to install or to replace this equipment. ⚡ E14

---

Professional installation is required.

This transmitter must not be co-located or operating in conjunction with any other antenna or transmitter.

### **Radiation Exposure Statement:**

This equipment complies with FCC radiation exposure limits set forth for an uncontrolled environment. This equipment using the dipole antenna should be installed and operated with minimum distance 46 cm between the radiator and your body; this equipment using the patch antenna should be installed and operated with minimum distance 51cm between the radiator and your body.

## Industry Canada Statement

---

This device contains license-exempt transmitter(s)/receiver(s) that comply with Innovation, Science and Economic Development Canada's license-exempt RSS(s). Operation is subject to the following two conditions:

- (1) This device may not cause interference.
- (2) This device must accept any interference, including interference that may cause undesired operation of the device.

L'émetteur/récepteur exempt de licence contenu dans le présent appareil est conforme aux CNR d'Innovation, Sciences et Développement économique Canada applicables aux appareils radio exempts de licence. L'exploitation est autorisée aux deux conditions suivantes :

- (1) L'appareil ne doit pas produire de brouillage;
- (2) L'appareil doit accepter tout brouillage radioélectrique subi, même si le brouillage est susceptible d'en compromettre le fonctionnement.

### **IC Radiation Exposure Statement**

This equipment complies with IC RSS-102 radiation exposure limit set forth for an uncontrolled environment. This equipment using the dipole antenna should be installed and operated with minimum distance 27cm between the radiator and your body; this equipment using the patch antenna should be installed and operated with minimum distance 31cm between the radiator and your body.

### **Déclaration d'exposition à la radiation**

Cet équipement respecte les limites d'exposition aux rayonnements IC définies pour un environnement non contrôlé. Cet équipement utilisant l'antenne dipôle doit être installé et utilisé avec une distance minimale de 27cm entre le radiateur et votre corps ; Cet équipement utilisant l'antenne patch doit être installé et utilisé avec une distance minimale de 31cm entre le radiateur et votre corps.

L'émetteur ne doit ni être utilisé avec une autre antenne ou un autre émetteur ni se trouver à leur proximité.

### **Caution**

- (i) the device for operation in the band 5150-5250 MHz is only for indoor use to reduce the potential for harmful interference to co-channel mobile satellite systems;
- (ii) the maximum antenna gain permitted for devices in the bands 5250-5350 MHz and 5470-5725 MHz shall comply with the e.i.r.p. limit; and
- (iii) the maximum antenna gain permitted for devices in the band 5725-5825 MHz shall comply with the e.i.r.p. limits specified for point-to-point and non point-to-point operation as appropriate.

(iv) Users should also be advised that high-power radars are allocated as primary users (i.e. priority users) of the bands 5250-5350 MHz and 5650-5850 MHz and that these radars could cause interference and/or damage to LE-LAN devices.

## **Avertissement**

Le guide d'utilisation des dispositifs pour réseaux locaux doit inclure des instructions précises sur les restrictions susmentionnées, notamment:

(i) les dispositifs fonctionnant dans la bande 5150-5250 MHz sont réservés uniquement pour une utilisation à l'intérieur afin de réduire les risques de brouillage préjudiciable aux systèmes de satellites mobiles utilisant les mêmes canaux;

(ii) le gain maximal d'antenne permis pour les dispositifs utilisant les bandes 5250-5350 MHz et 5470-5725 MHz doit se conformer à la limite de p.i.r.e.;

(iii) le gain maximal d'antenne permis (pour les dispositifs utilisant la bande 5725-5825 MHz) doit se conformer à la limite de p.i.r.e. spécifiée pour l'exploitation point à point et non point à point, selon le cas.

(iv) De plus, les utilisateurs devraient aussi être avisés que les utilisateurs de radars de haute puissance sont désignés utilisateurs principaux (c.-à-d., qu'ils ont la priorité) pour les bandes 5250-5350 MHz et 5650-5850MHz et que ces radars pourraient causer du brouillage et/ou des dommages aux dispositifs LAN-EL.

## **Professional Installation Instruction**

### **Installation personnel**

This product is designed for specific application and needs to be installed by a qualified personnel who has RF and related rule knowledge. The general user shall not attempt to install or change the setting.

## **Instructions d'installation professionnelle:**

### **Installation personnelle**

Ce produit est destiné à un usage spécifique et doit être installé par un personnel qualifié maîtrisant les radiofréquences et les règles s'y rapportant. L'installation et les réglages ne doivent pas être modifiés par l'utilisateur final.

## Europe - EU Declaration of Conformity

---

Hereby, Allied Telesis declares that the radio equipment type [AT-TQ6702e GEN2-R] is in compliance with Directive 2014/53/EU.

### Operating Frequencies and Maximum Transmission Power Levels

The operating frequencies and maximum transmission power levels for wireless devices operated in the EU are listed below:

AT-TQ6702e GEN2-R

	Beamforming	Non-Beamforming
2412-2472 MHz	19.87 dBm	19.94 dBm
5150-5250 MHz	22.87 dBm	22.99 dBm
5250-5350 MHz	22.99 dBm	22.96 dBm
5470-5725 MHz	29.97 dBm	29.83 dBm

#### Note

Operations in the 5.15 - 5.35 GHz band are restricted to indoor usage only.

### Radiation Exposure Statement

This equipment complies with EU radiation exposure limits set forth for an uncontrolled environment. This equipment should be installed and operated with a minimum distance of 20 cm between the radiator and your body.



AT	BE	BG	CH	CY	CZ	DE	DK	EE
EL	ES	FI	FR	HR	HU	IE	IS	IT
LI	LT	LU	LV	MT	NL	NO	PL	PT
RO	SE	SI	SK	TR	UK			

### Importer

Allied Telesis International BV  
Incheonweg 7, 1437 EK Rozenburg

#### Note

Contact Allied Telesis for the EU conformity statement. To contact Allied Telesis, visit our web site at [www.alliedtelesis.com/contact](http://www.alliedtelesis.com/contact).

## UK - UKCA Declaration of Conformity

---

Hereby, Allied Telesis declares that the radio equipment type [AT-TQ6702e GEN2 and AT-TQ6702e GEN2-R] are in compliance with The Radio Equipment Regulations 2017.

### Operating Frequencies and Maximum Transmission Power Levels

The operating frequencies and maximum transmission power levels for wireless devices operated in the UKCA are listed below:

#### Access Point with the Dipole Antennas (default)

Operating Frequencies	Beamforming	Non-Beamforming
2412-2472 MHz	19.98 dBm	19.96 dBm
5180-5240 MHz	22.81 dBm	22.87 dBm
5260-5320 MHz	22.7 dBm	22.65 dBm
5500-5700 MHz	29.75 dBm	29.87 dBm

#### Access Point with the Optional AT-TQ0301 Patch Antenna

Operating Frequencies	Beamforming	Non-Beamforming
2412-2472 MHz	19.98 dBm	19.98 dBm
5180-5240 MHz	22.91 dBm	22.85 dBm
5260-5320 MHz	22.97 dBm	22.87 dBm
5500-5700 MHz	29.96 dBm	29.96 dBm

### Radiation Exposure Statement

This equipment complies with UK radiation exposure limits set forth for an uncontrolled environment. This equipment should be installed and operated with a minimum distance of 20 cm between the radiator and your body.



### Importer

Allied Telesis International BV 11 Pine Court, Kembrey Park Swindon Wiltshire SN2 8AD, United Kingdom

#### Note

Contact Allied Telesis for the UK conformity statement. To contact Allied Telesis, visit our web site at [www.alliedtelesis.com/contact](http://www.alliedtelesis.com/contact).

## **European Union Restriction of the Use of Certain Hazardous Substances (RoHS) in Electrical and Electronic Equipment**

---

This Allied Telesis RoHS-compliant product conforms to the European Union Restriction of the Use of Certain Hazardous Substances (RoHS) in Electrical and Electronic Equipment. Allied Telesis ensures RoHS conformance by requiring supplier Declarations of Conformity, monitoring incoming materials, and maintaining manufacturing process controls.

## Appendix C

# Radiation Patterns

---

This appendix contains the following sections:

- “Antenna Locations and Axes” on page 91
- “2.4/5GHz Dual (2.4GHz) Radiation Patterns” on page 91
- “2.4/5GHz Dual (5GHz) Radiation Patterns” on page 92
- “5GHz Single (5GHz) Radiation Patterns” on page 92

## Antenna Locations and Axes

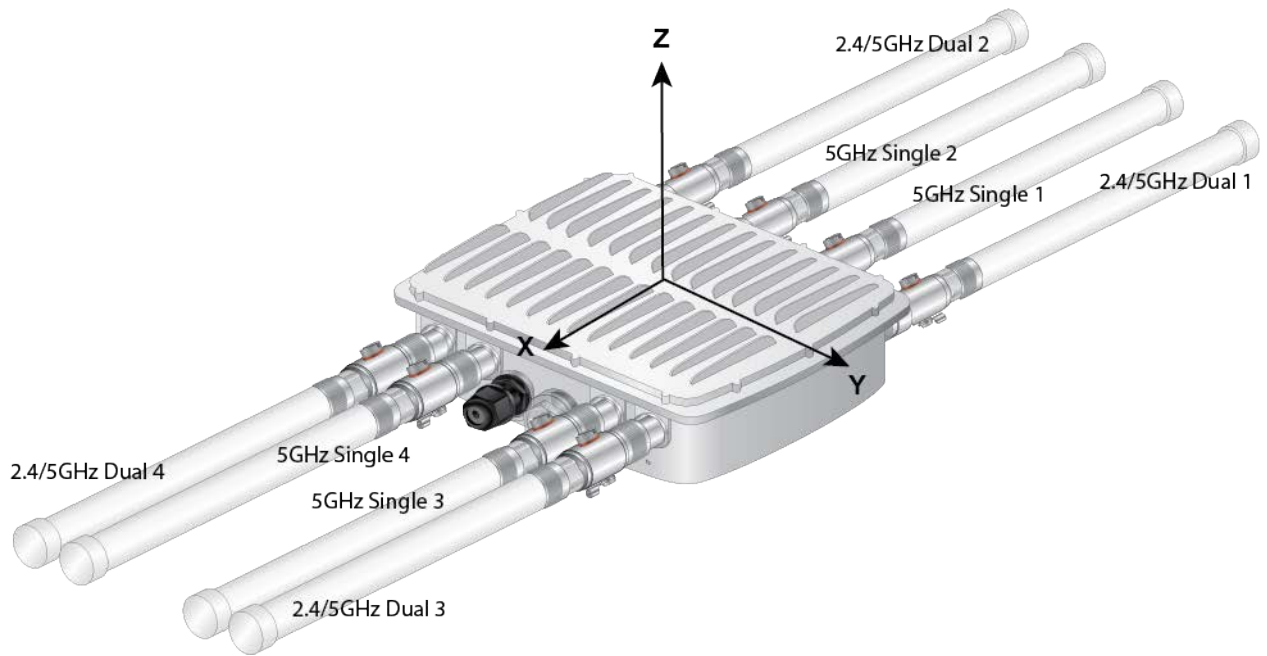

Figure 47. Antenna Locations and Axes

## 2.4/5GHz Dual (2.4GHz) Radiation Patterns



Figure 48. 2.4/5GHz Dual (2.4GHz) Radiation Patterns

## 2.4/5GHz Dual (5GHz) Radiation Patterns

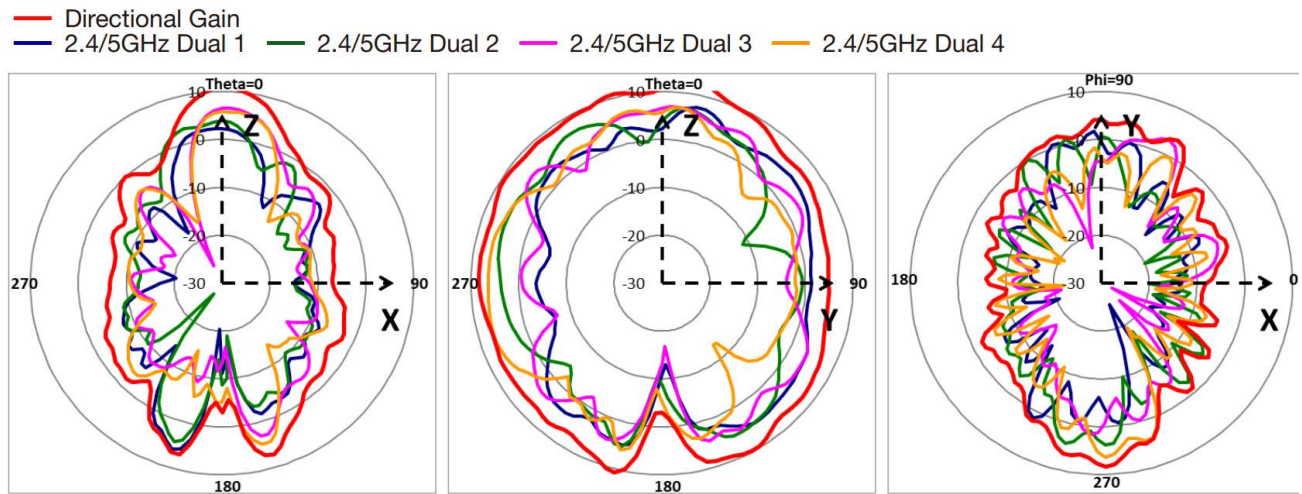

Figure 49. 2.4/5GHz Dual (5GHz) Radiation Patterns

## 5GHz Single (5GHz) Radiation Patterns

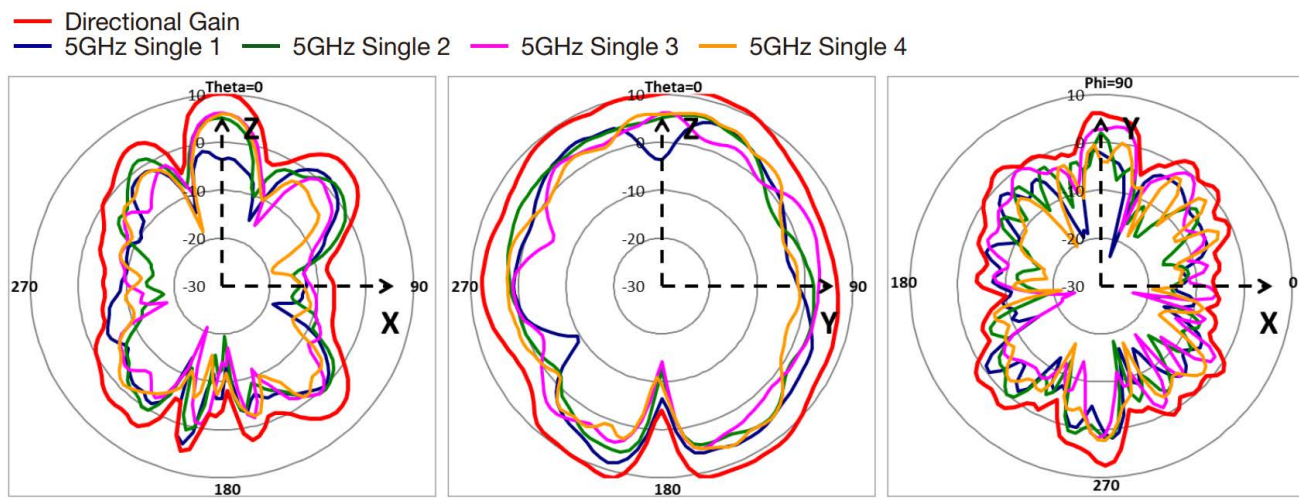

Figure 50. 5GHz Single (5GHz) Radiation Patterns