

AlliedView™-EMS 4.0.1

DEVICE MANAGEMENT GUIDE

TABLE OF CONTENTS

BASIC OPERATIONS.....	9
COMMON OPERATIONS ON THE MAIN WINDOW	9
MENU FOR STACKED DEVICES.....	10
PORT SELECTION DIALOG BOX.....	11
PORT STATUS COLORS	11
LED STATUS	11
UTILIZATION	12
LAYER 2 SWITCHES.....	13
AT-8000 SERIES	13
Main Window	13
Agent Menu.....	20
Bridge Menu.....	21
RMON Menu	22
Port Menu	22
Stacking Menu.....	24
Expansion Module Notes.....	24
AT-8000/8POE.....	26
Main Window	26
Agent Menu.....	27
Bridge Menu.....	28
RMON Menu	28
Port Menu	29
AT-8000GS SERIES.....	31
Main Window	32
Agent Menu.....	33
Routing Menu	40
Bridge Menu.....	44
IGMP Menu	46
Security Menu.....	46
RMON Menu	50
Port Menu	51
AT-8000S SERIES.....	57
Main Window	57
Agent Menu.....	59
Routing Menu	65
Bridge Menu.....	68
IGMP Menu	69
Security Menu.....	70
RMON Menu	73
Port Menu	74
AT-8300GB SERIES	79
Main Window	80
Agent Menu.....	82
Bridge Menu.....	83
RMON Menu	83
Port Menu	84
Stacking Menu.....	85

AT-8400	86
Main Window	87
Agent Menu.....	88
Bridge Menu.....	89
RMON Menu	90
Port Menu	90
Stacking Menu.....	92
AT-8400 LINE CARDS.....	93
AT-8411	93
AT-8412.....	94
AT-8413.....	95
AT-8414.....	96
AT-9000/24.....	97
Main Window	97
Agent Menu.....	98
Bridge Menu.....	99
RMON Menu	99
Port Menu	100
AT-9006 FAMILY	102
Main Window	102
Agent Menu.....	103
Bridge Menu.....	104
RMON Menu	104
VLAN Menu	105
Port Menu	105
AT-9410GB.....	106
Main Window	106
Agent Menu.....	107
Bridge Menu.....	108
RMON Menu	108
Port Menu	109
ROUTERS.....	111
AT-AR400S SERIES	111
Main Window	111
Agent Menu.....	114
Routing Menu	114
Bridge Menu.....	115
ATM Menu	115
ADSL Menu.....	116
SHDSL Menu	116
Port Menu	117
AT-AR410.....	118
Main Window	118
Agent Menu.....	119
Routing Menu	119
Bridge Menu.....	120
Frame Relay Menu.....	120
Call List Menu.....	120

Port Menu	121
AT-AR700 SERIES.....	122
Main Window	122
Agent Menu.....	124
Routing Menu	124
Bridge Menu.....	125
Frame Relay Menu	125
Call List Menu.....	125
Port Menu	126
AT-AR700S SERIES	127
Main Window	127
Agent Menu.....	129
Routing Menu	132
LAN/WAN Menu	134
Availability Menu	138
Security Menu.....	139
RMON Menu	141
Port Menu	141
ADVANCED LAYER 2 SWITCHES.....	143
AT-8500 SERIES	143
Main Window	143
Agent Menu.....	146
Routing Menu	148
Bridge Menu.....	149
RMON Menu	149
Port Menu	150
Stacking Menu.....	153
Expansion Module Notes.....	153
AT-8700XL SERIES.....	155
Main Window	155
Agent Menu.....	157
Routing Menu	158
Bridge Menu.....	158
Port Menu	159
LAYER 3 SWITCHES.....	160
AT-8600 SERIES	160
Main Window	160
Agent Menu.....	162
Routing Menu	163
Bridge Menu.....	163
Port Menu	164
Expansion Module Notes.....	164
AT-8800 SERIES	165
Main Window	165
Agent Menu.....	166
Routing Menu	167
Bridge Menu.....	168
Port Menu	168

AT-8948	170
Main Window	170
Agent Menu.....	171
Routing Menu	174
Bridge Menu.....	175
LLDP Menu	176
Availability Menu.....	177
Security Menu.....	179
RMON Menu	180
Port Menu	180
AT-X900-48 SERIES.....	183
Main Window	183
Agent Menu.....	185
Routing Menu	187
Bridge Menu.....	189
LLDP Menu	190
Availability Menu.....	191
Security Menu.....	192
RMON Menu	194
Port Menu	194
RAPIER.....	197
Main Window	197
Agent Menu.....	202
Routing Menu	203
BRIDGE MENU	203
Frame Relay Menu	204
Call List Menu.....	204
Port Menu	205
AT-RAPIER 48W	206
Main Window	206
Agent Menu.....	207
Routing Menu	210
LAN/WAN Menu	212
Availability Menu.....	215
Security Menu.....	217
RMON Menu	218
Port Menu	218
SWITCHBLADE	221
Main Window	222
Agent Menu.....	224
Routing Menu	225
Bridge Menu.....	225
Port Menu	226
SWITCHBLADE LINE CARDS.....	228
MULTI-LAYER GIGABIT SWITCHES	231
AT-9400 SERIES	231
Main Window	231
Agent Menu.....	236

Routing Menu	239
Bridge Menu.....	240
Security Menu.....	241
RMON Menu	242
Port Menu	243
Stacking Menu.....	246
AT-9700 SERIES	247
Main Window	247
Agent Menu.....	250
Routing Menu	253
Bridge Menu.....	262
IGMP Menu	263
VRRP Menu	264
Security Menu.....	265
RMON Menu	270
Port Menu	271
Expansion Module Notes.....	275
AT-9800 SERIES	276
Main Window	276
Agent Menu.....	278
Routing Menu	279
Bridge Menu.....	279
Port Menu	280
AT-9900/AT-9900S SERIES	281
Main Window	281
Agent Menu.....	284
Routing Menu	284
Bridge Menu.....	285
Port Menu	285
AT-X600 SERIES.....	287
Main Window	287
Agent Menu.....	291
Routing Menu	298
Bridge Menu.....	300
Availability Menu.....	301
RMON Menu	301
Port Menu	301
Stacking Menu.....	305
AT-X900-12X SERIES.....	306
Main Window	306
Agent Menu.....	308
Routing Menu	314
Bridge Menu.....	316
Availability Menu.....	317
RMON Menu	317
Port Menu	318
Stacking Menu.....	321
AT-X900-24X SERIES (ALLIEDWARE).....	322
Main Window	322

Agent Menu.....	324
Routing Menu	328
Bridge Menu.....	329
LLDP Menu	330
Security Menu.....	331
RMON Menu	333
Port Menu	333
AT-X900-24X SERIES (ALLIEDWARE PLUS)	337
Main Window	337
Agent Menu.....	339
Routing Menu	346
Bridge Menu.....	348
Availability Menu.....	349
RMON Menu	349
Port Menu	350
Stacking Menu.....	353
SWITCHBLADE X908.....	354
Main Window	354
Agent Menu.....	356
ROUTING MENU.....	362
BRIDGE MENU.....	364
AVAILABILITY MENU	365
RMON MENU	365
PORT MENU	366
Stacking Menu.....	369
MEDIA CONVERTERS.....	371
CONVERTEON SERIES	371
Main Window	371
AGENT MENU	374
STATUS MENU.....	375
OAM Menu	377
CONVERTEON SERIES MODULES	378
AT-MCF2000 MEDIA CONVERTER.....	386
MAIN WINDOW	386
AGENT MENU	388
STATUS MENU.....	390
AT-MCF2000 MODULES.....	392
AT-MCF2000M	392
AT-MCF2000S.....	392
AT-MCF2012LC	393
AT-MCF2012LC/I	393
POWERBLADE	395
Main Window	395
AGENT MENU	396
Status Menu.....	397
POWERBLADE MODULES	398
AT-PB10 Series Media Converter Modules	398
AT-PB100 Series Media Converter Modules	399
AT-PB200 Series Switch Modules.....	400
AT-PB300 Series Media Converter Modules	401

AT-PB1000 Series Media Converter Modules 402

EXPANSION GATEWAYS 403

PORT INTERFACE CARDS 403

NETWORK SERVICE MODULES 405

UPLINK MODULES..... 407

Basic Operations

Device Manager's main window shows the main panel of the target device. It has both common and device-specific menus on its menu bar.

Note - SNMPv3: All device-specific menu options are displayed regardless of the user's view access security settings.

You can perform operations on the agent by doing a right click on the main panel or by selecting a menu item from the menu bar. Ports and LEDs on the main panel indicate the status of the port, system and traffic.

Topics:

- Common operations on the main window
- Menu for stacked devices
- Port selection dialog box
- Port status colors
- LED status
- Utilization

Common operations on the main window

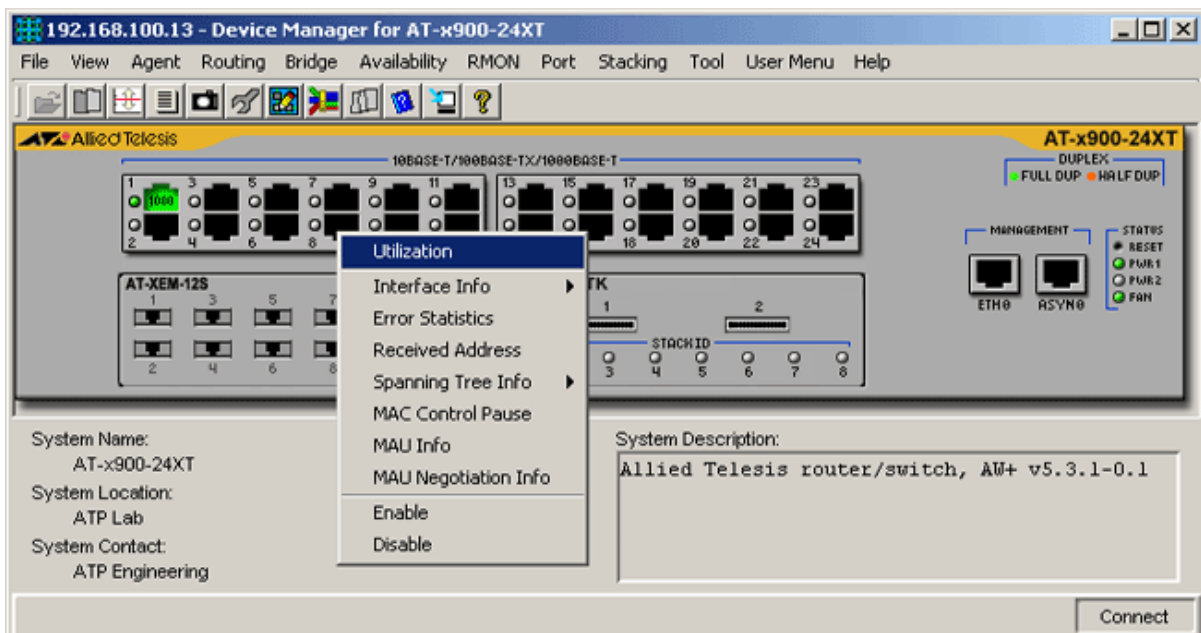

Right clicking on a port

Port

Right clicking on a port opens a pull-down menu specific to the device. Selecting a menu item opens another window and lets you view and edit MIB information related to the port. You can also access the same menu from the menu bar.

RS-232 Terminal Port

Right clicking on an RS-232 port opens a pull-down menu and lets you choose how to log into the agent. Depending on the managed device, choose Telnet or WEB Browser.

Reset Button

Right clicking on a reset button opens a pull-down menu with an option that allows you to reset the device. (Not available on some devices.)

Menu for stacked devices

If the target is a stacked device, some menus have extra subitems to specify a single device in the stack.

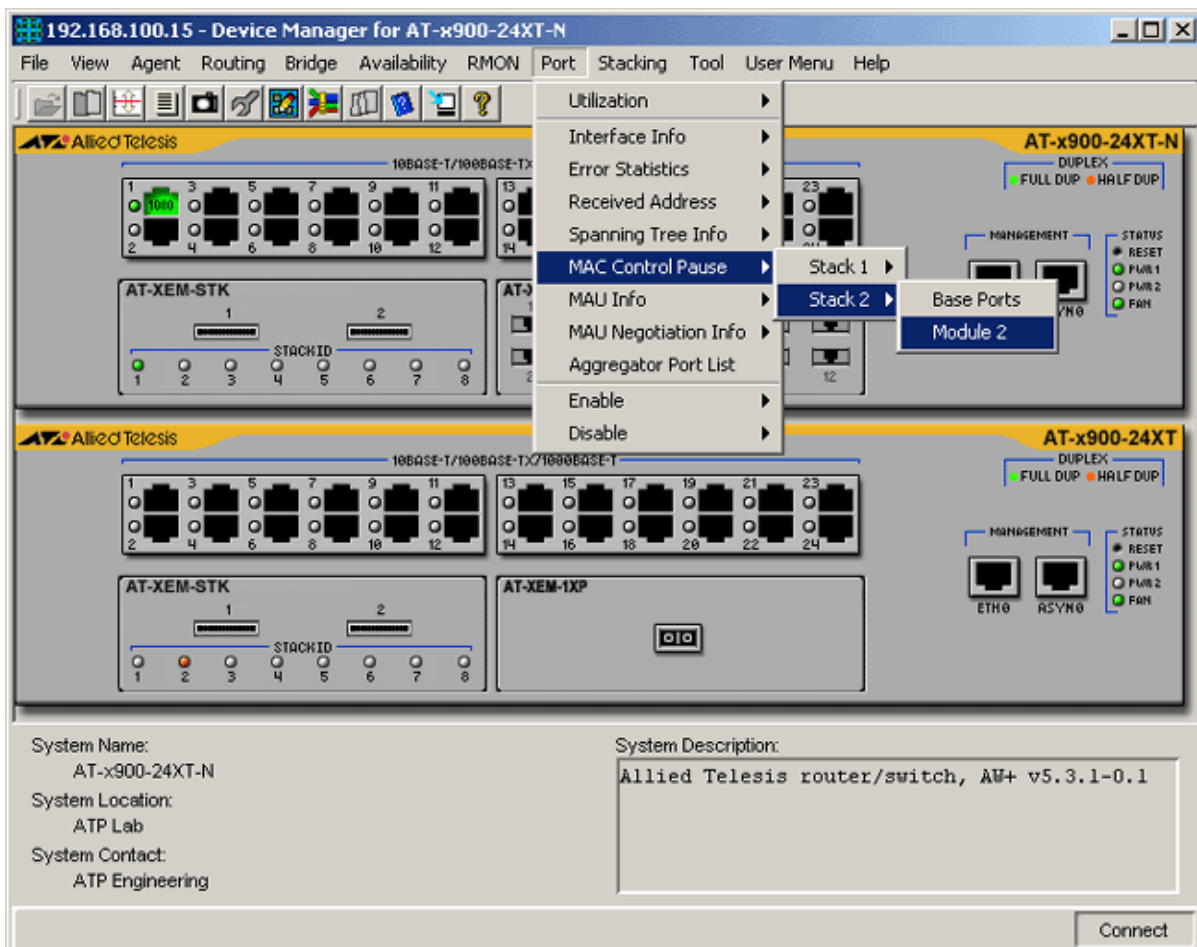

Module submenu

Port selection dialog box

When you select a menu item acting on ports, a dialog box opens to let you select ports. Check the target ports and click OK.

Note - If you select multiple ports, it may take some time for data to be displayed.

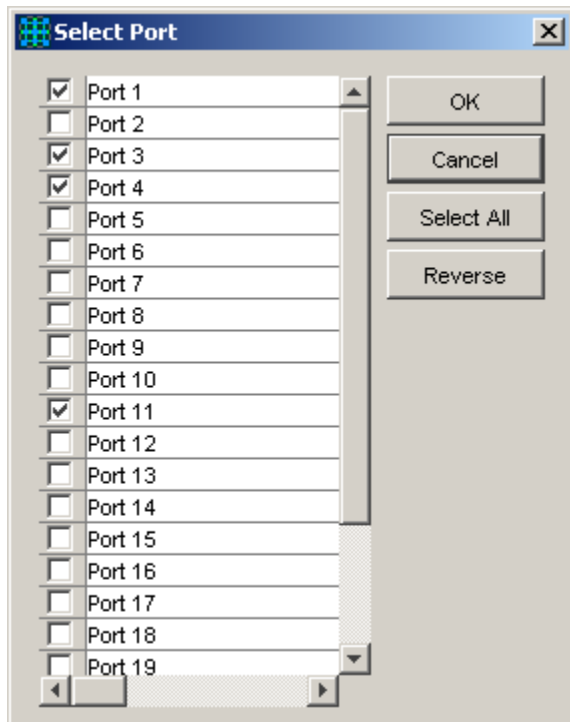

Select Port dialog box

Port status colors

Port status is shown by its color. Port speed is also displayed in the port image.

- Link Up: Green
- Disabled: Red (the port is disabled by an administrator)
- Partitioned/Blocking: Yellow
- Others: Default colour (usually black)

Note - SNMPv3: Depending on the READ VIEW access settings of the User Account Name used, there is a possibility that Device Manager may not be able to access some MIB values that control the Port status. When this happens, the affected ports will be shown in the default color.

LED status

In Device Manager, LEDs do not blink. The meaning of each LED will differ from one device to another.

Utilization

Utilization is calculated by the following formula.

$$\text{Utilization (\%)} = \frac{\# \text{ of frames} \times (96 + 64) + \text{octets} \times 8}{\text{Port speed (bps)} \times \text{Sampling Interval(sec)}} \times 100$$

Layer 2 Switches

AT-8000 Series

This section describes Device Manager menus and operations specific to the AT-8000 Series.

Topics:

- Main Window
- Agent Menu
- Bridge Menu
- RMON Menu
- Port Menu
- Stacking Menu
- Expansion Module Notes

Main Window

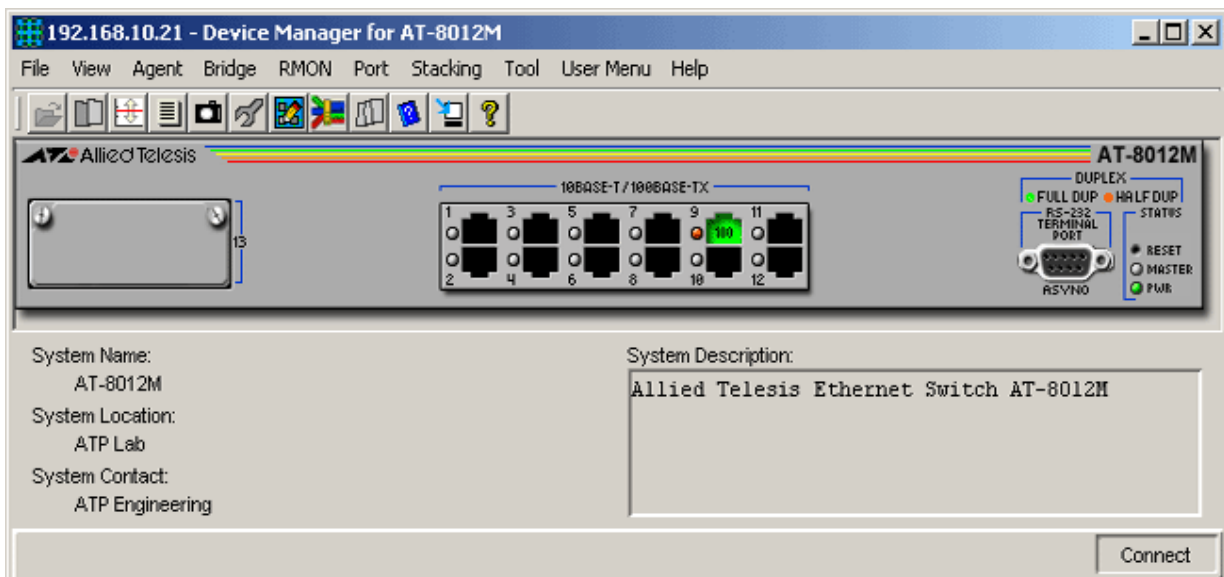

AT-8012M

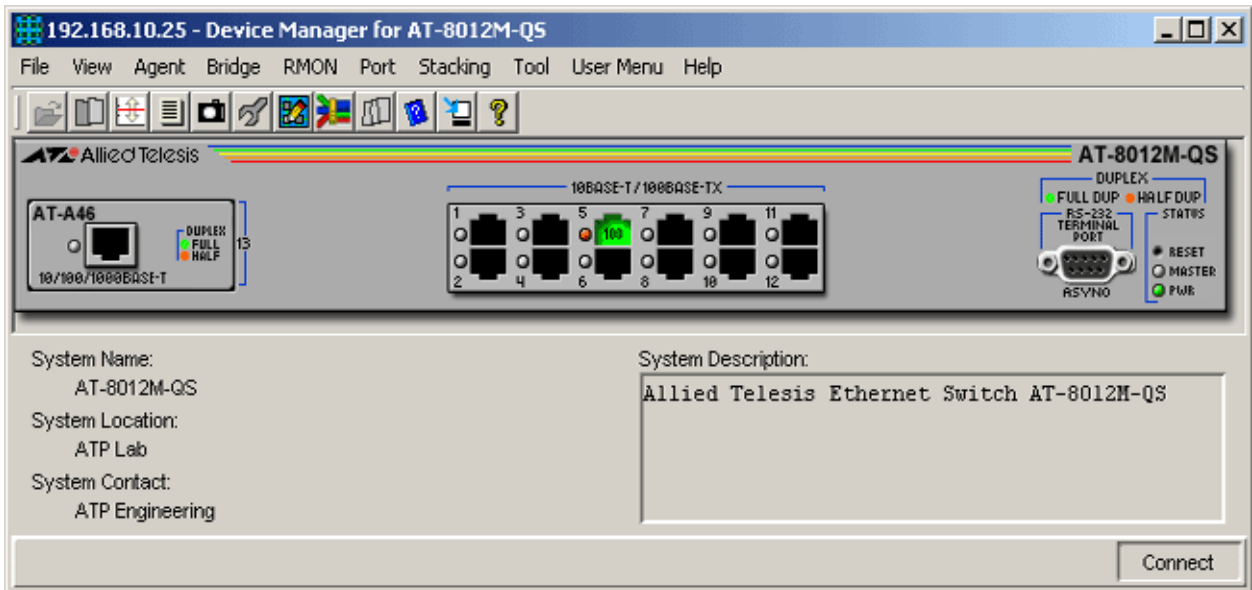

AT-8012M-QS

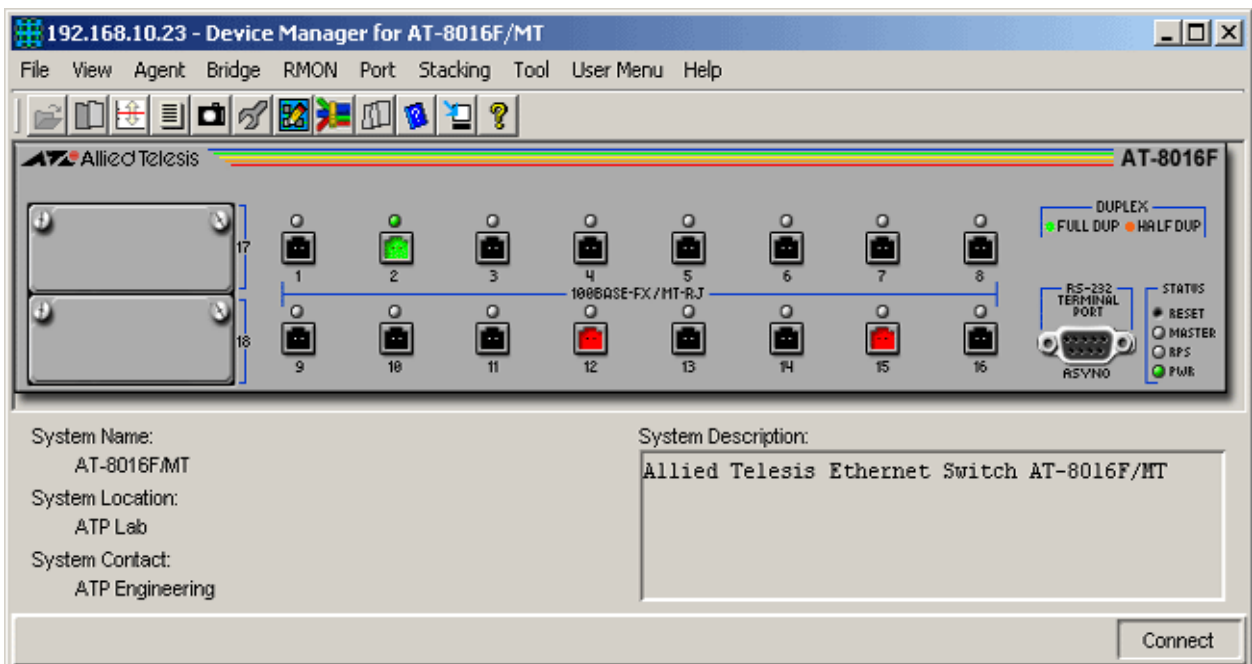

AT-8016F/MT

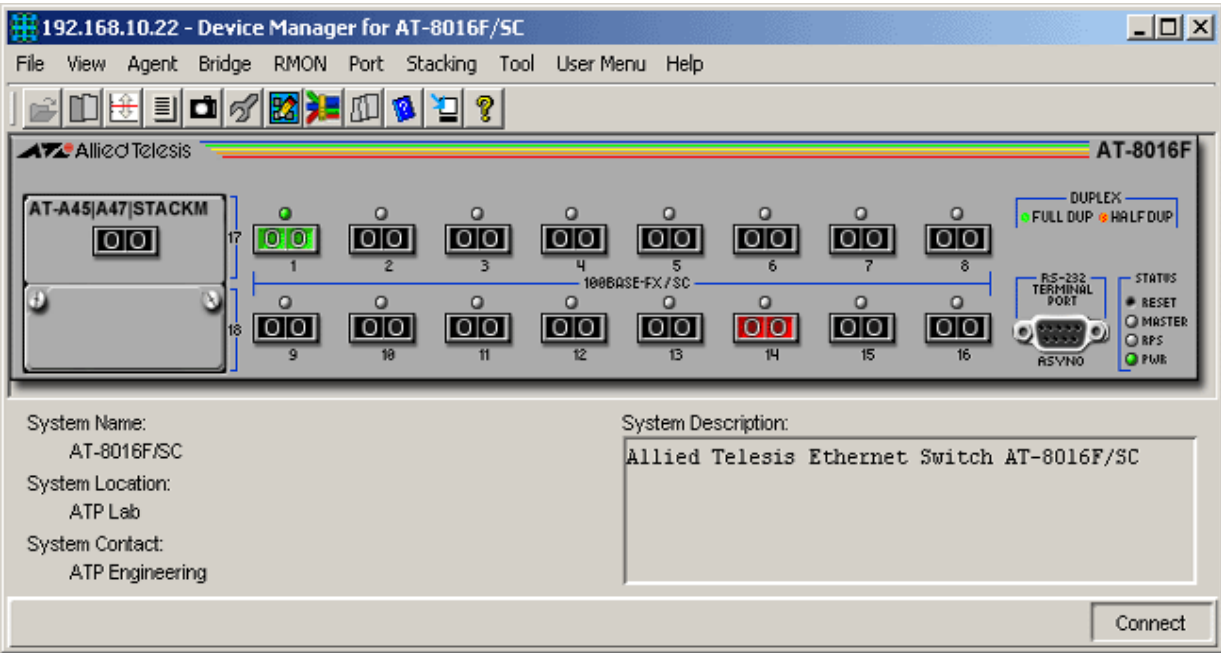

AT-8016F/SC

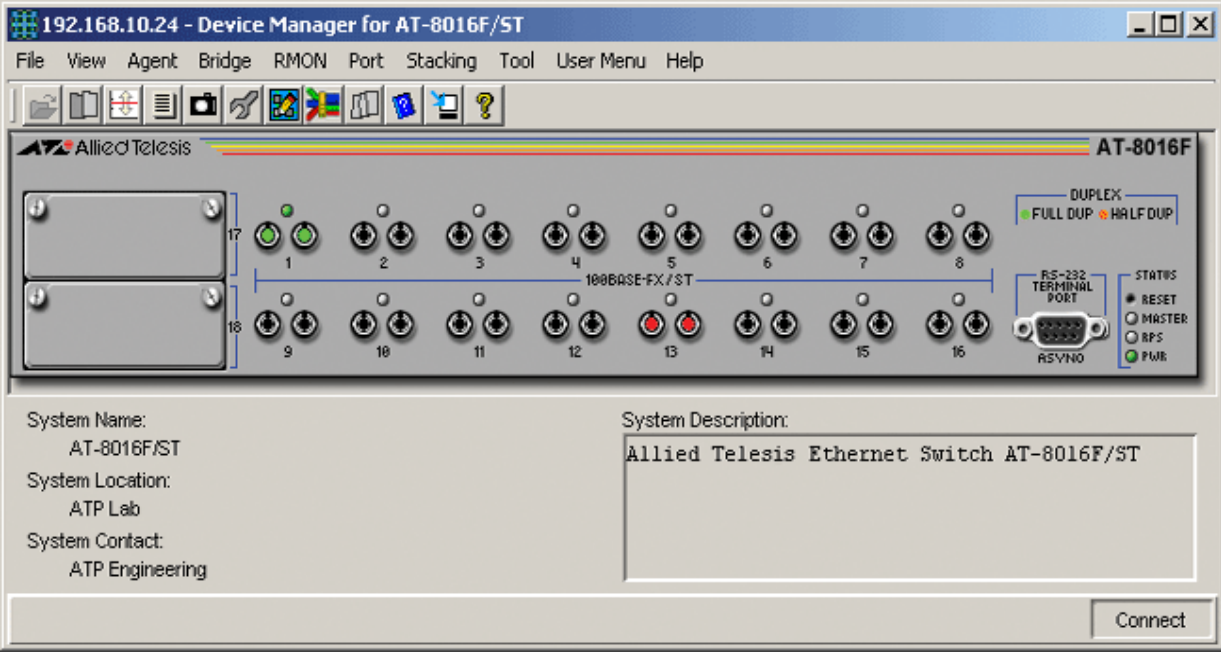

AT-8016F/ST

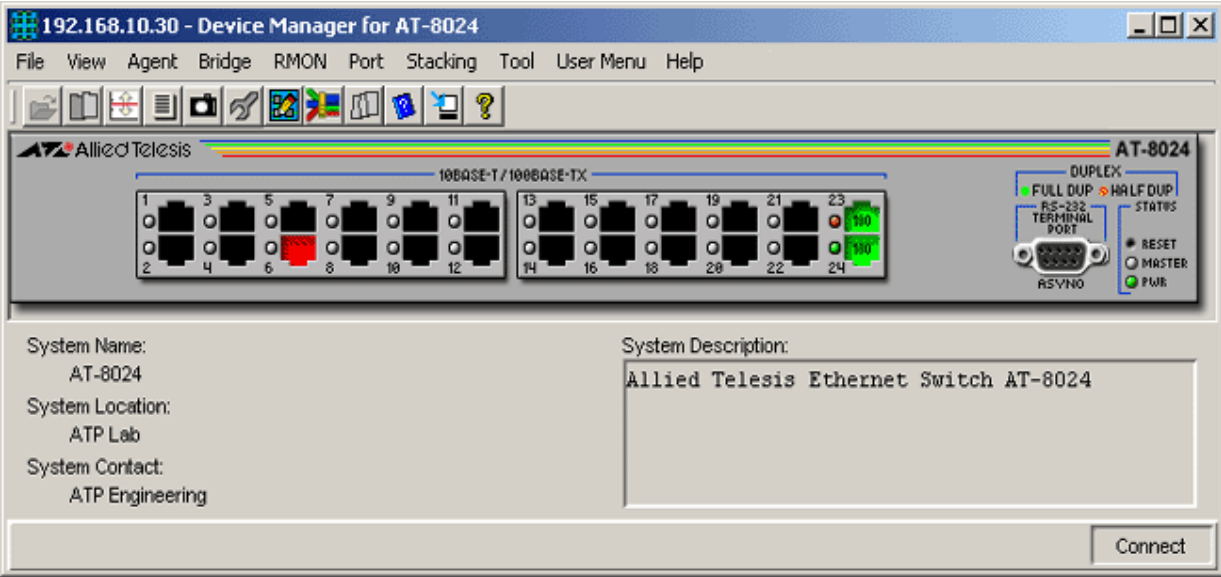

AT-8024

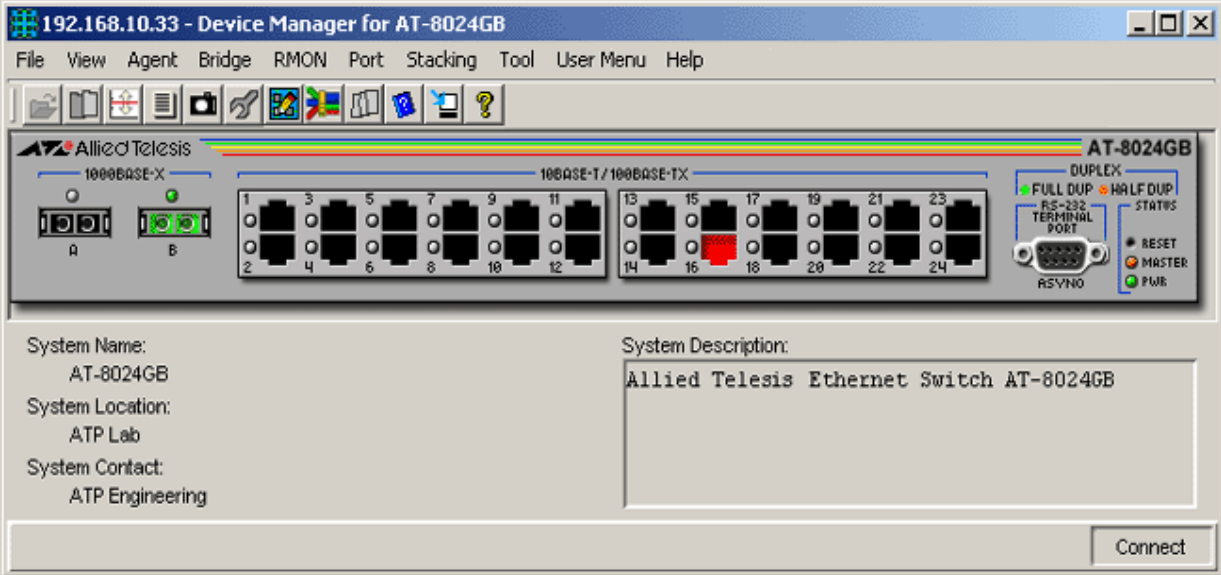

AT-8024GB

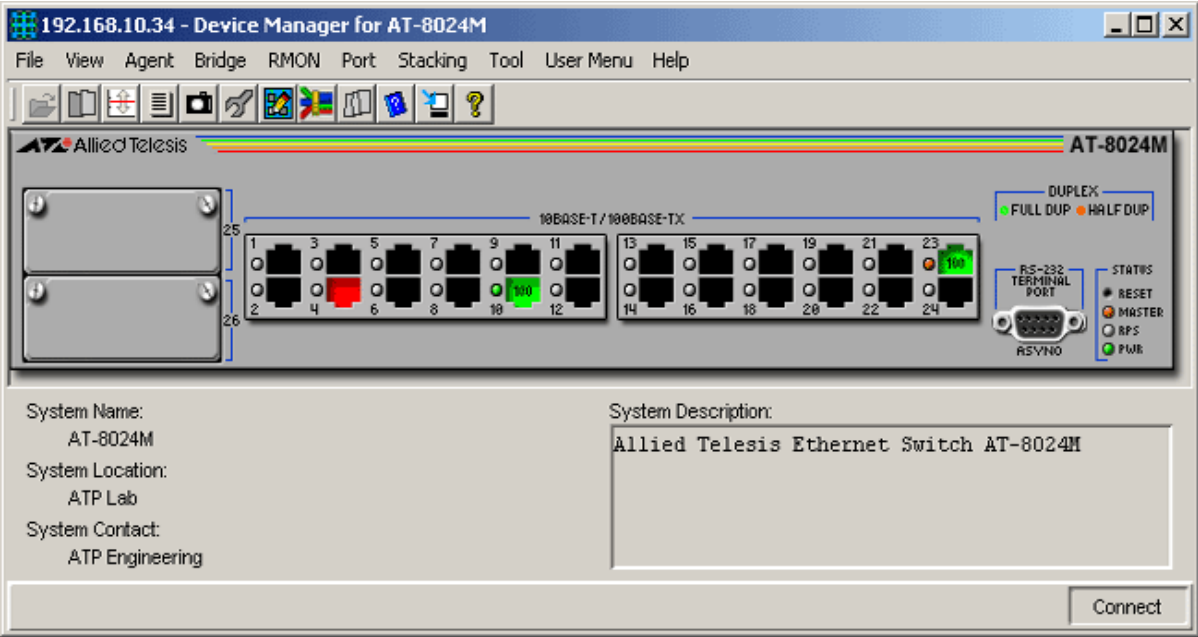

AT-8024M

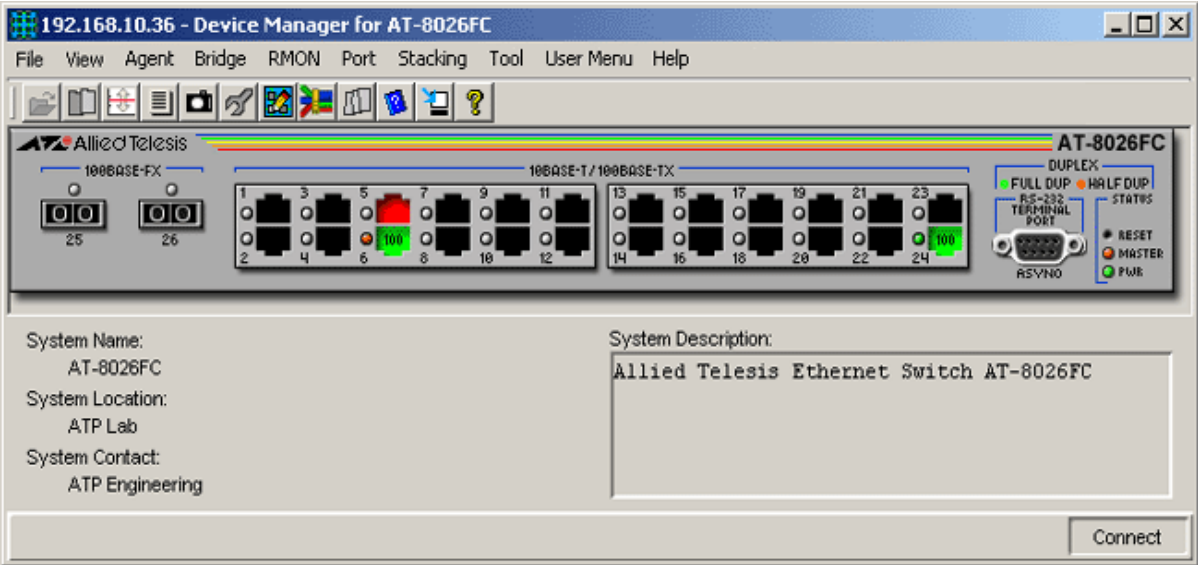

AT-8026FC

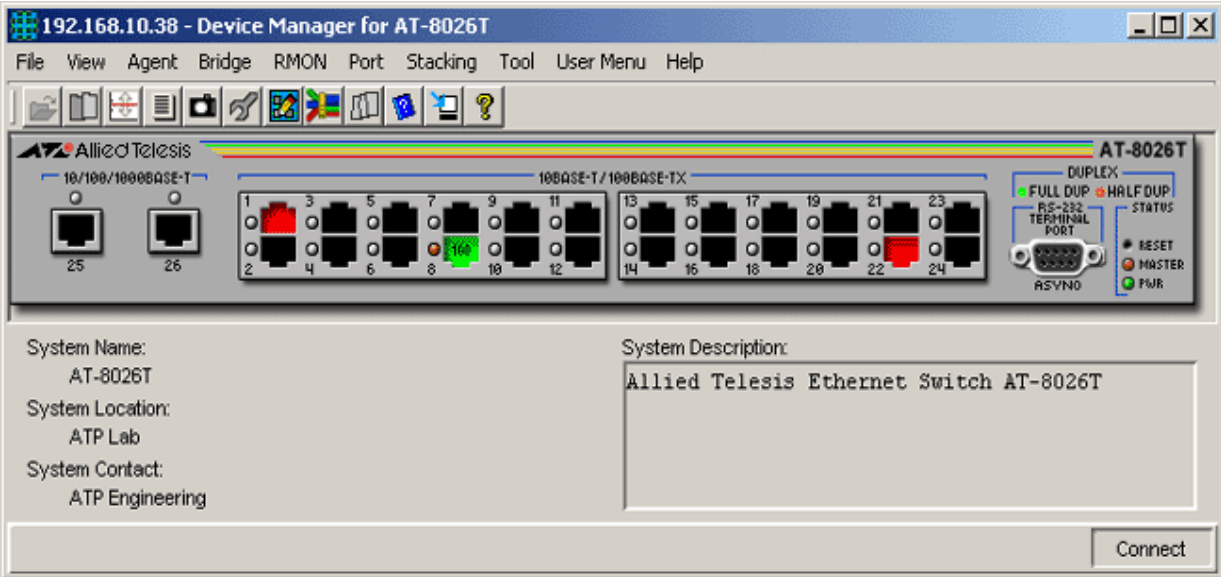

AT-8026T

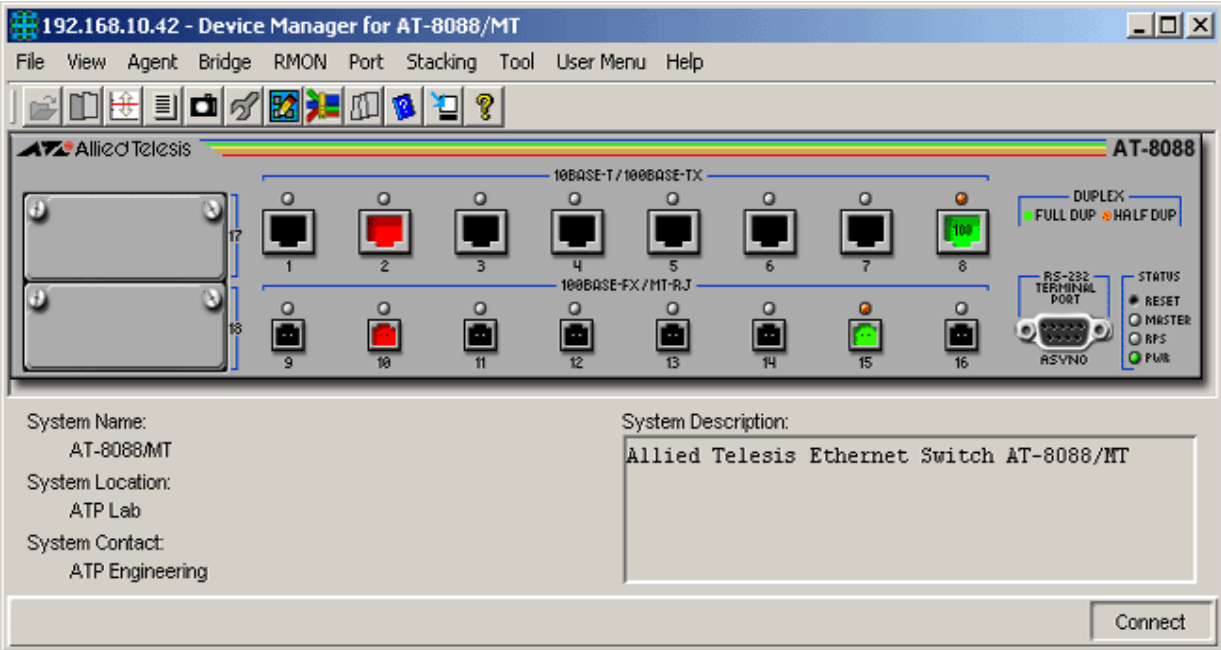

AT-8088/MT

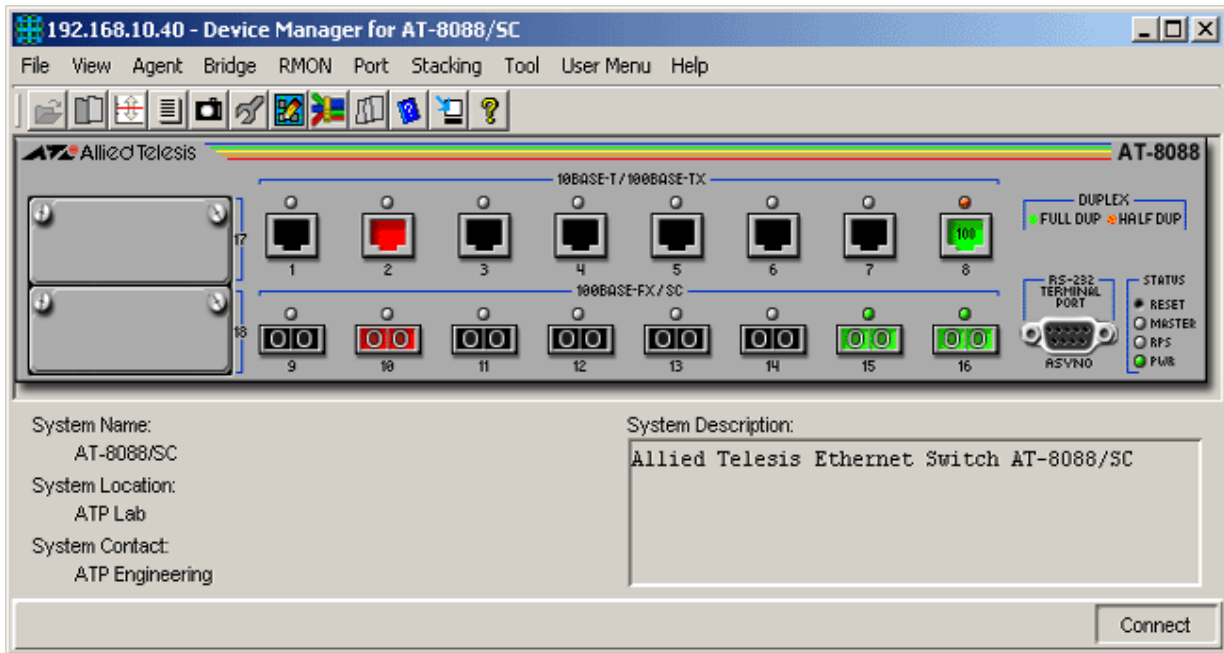

AT-8088/SC

Device Manager LEDs for AT-8000 Series

LED	State	Description
PWR	Green	The switch is receiving power.
MASTER	Orange	The switch is the master switch of an enhanced stack.
	Gray	The switch is a slave switch or is not a member of an enhanced stack.
DUPLEX	Green	The port is operating in full-duplex mode.
	Orange	The port is operating in half-duplex mode.

Note - Please refer to Uplink Modules for the operations and behavior of the expansion modules installed on these devices.

Note - The current firmware version does not allow Device Manager to support the RPS LED.

Note - When connecting to a slave switch, Device Manager does not automatically replace the master switch image in the main window with the slave switch image. To view the slave switch image, click on the Refresh option under the Agent menu.

Note - Device Manager will detect a loss of connection between an AT-8024GB and an AT-9410GB when the uplink port on both devices are set to the same speed and mode.

Note - Connection between an AT-8024GB and an AT-8324 can only be established if the uplink ports on both devices are configured to auto-negotiate.

Note - Setting the 'Active Protocol Version' to 'STP' and 'Spanning Tree Status' to 'enabled' will set the Port State parameter of disabled ports to 'blocking'. As a result, port images for disabled ports will turn yellow.

Note - Setting the 'Active Protocol Version' to 'RSTP' and 'Spanning Tree Status' to 'enabled' will set the Port State parameter of inactive ports and disabled ports to 'blocking'. As a result, port images for inactive ports and disabled ports will turn yellow.

Agent Menu

From the Agent menu, you can view and edit the system information for the device, or log into the CLI using Telnet.

System Info

Displays basic system information, including system name, location, contact and description.

Note - Attempting to set the System Contact, System Name, and System Location parameters to NULL will result in a general error. However, the parameters will still be temporarily set to NULL. Once the switch is restarted, the original values will be restored.

Note - The current firmware version accepts up to 40 characters for the System Contact, System Name and System Location parameters. However, specifying a value that is exactly 40 characters in length will result in an error message. This error message may be ignored as the value will still be set successfully.

Firmware Info

Displays firmware version.

Network Info

Displays network-related information such as the addresses of the default gateway and the agents.

Note - The current firmware version does not allow the Default Domain Name and the DNS Server parameters to be configured.

Manager Address Info

Displays the IP address of the management station.

Device Info

Displays general information about the switch.

MAC Address Table

Displays a list of static MAC addresses configured on the switch.

Note - MAC Address Table entries created through a local or telnet management session will not be visible to Device Manager until the device is restarted.

Reset

Resets the switch.

Telnet

Starts a Telnet connection to the switch.

WEB Browser

Connects to the switch's HTTP server.

Bridge Menu

From the Bridge menu, you can view and edit bridge information such as the forwarding database and the spanning tree status.

Forwarding Database

Note - AT-8016F/xx: The current firmware version may, at times, return duplicate Forwarding Database table entries.

Standard View

Displays the Forwarding Database table as returned by the device.

Enhanced View

Displays the Forwarding Database table on a per port basis. User can select a port or group of ports to view its corresponding Forwarding Database entries.

Discard/Aging Time Info

Displays information about the number of address entries that were learned but discarded because either there was a lack of memory or the entry's aging timer expired.

Note - The current firmware version accepts values in the range [10-1000000] inclusive for the Aging Time parameter.

Spanning Tree Info

Displays spanning tree parameters such as priority and cost.

Note - The current firmware version accepts values in the range [0-65535] inclusive for the Priority parameter regardless of the active spanning tree protocol version.

Statistics

Displays statistics about frames received/transmitted on the switch port.

RMON Menu

From the RMON menu you can view and edit the RMON MIB.

Statistics

Displays traffic statistics in the network segment attached to each port.

History Control Table

Displays the RMON History table.

Note - The current firmware version does not support the "historyControlTable" MIB object of RFC1757. As a result, Device Manager displays the error message "Failed to get MIB data." when the History Control Table option is selected from the RMON menu.

Alarm Table

Displays the RMON Alarm table.

Event Table

Displays the RMON Event table.

Event Log

Displays the RMON Event log.

Port Menu

From the Port menu, you can view and edit MIB information about the port.

Utilization

Displays the port's utilization information.

Interface Info

Displays port statistics such as the number of frames received and transmitted on the port, bytes received and transmitted on the port, and port status.

Note - Valid MIB Set values for the Administration Status parameter are 'up' and 'down'. Attempting to set this parameter to any other value will result in the error message: "The error occurred with 'Set' operation. Error: bad value."

Error Statistics

Displays error statistics.

Detail Info

Displays detailed port information such as duplex mode.

Note - Valid MIB Set values for the Port Flow Control parameter are 'disable', 'transmit-only', 'receive-only', and 'transmit-and-receive'. However, the current firmware version does not allow this parameter to be set to 'transmit-only' and 'receive-only' for the following ports:

- Expansion module ports
- GBIC ports on the AT-8024GB
- Fiber optic ports on the AT-8026FC

Note - Valid MIB Set values for the Port State parameter are 'enabled' and 'disabled'. Attempting to set this parameter to any other value will result in the error message: "The error occurred with 'Set' operation. Error: bad value."

Note - The current firmware version accepts up to 20 characters for the Port Name parameter. Attempting to enter more than 20 characters will result in an error message and may append additional characters to the input value.

Spanning Tree Info

Displays the port's spanning tree parameters.

Note - Setting a port's Port parameter to 'disabled' does not automatically set the Port State parameter under Detail Info to 'disabled'. As a result, the port's image may not turn red as expected.

Note - The current firmware version accepts values in the range [0-255] inclusive for the Port Priority parameter regardless of the active spanning tree protocol version.

Note - The current firmware version accepts values in the range [0-65535] inclusive for the Port Path Cost parameter regardless of the active spanning tree protocol version.

Enable

Enables the port.

Note - Under the Sun Solaris platform, the Device Manager application may terminate abnormally if multiple ports have been selected and each dialog box with the message "May I set 'atiswitchPortState.n' to up" is clicked one after the other.

Disable

Disables the port.

Note - Under the Sun Solaris platform, the Device Manager application may terminate abnormally if multiple ports have been selected and each dialog box with the message "May I set 'atiswitchPortState.n' to down" is clicked one after the other.

Port Mirroring

Displays port mirroring parameters and allows configuration of port mirroring state, source, and destination.

Note - Valid MIB Set values for the Mirroring Destination Port parameter should range from 0 to 24. However, the current firmware version allows the user to enter values up to 65535. Attempting to enter values greater than 65535 will cause the new value to be converted to its equivalent wrap-around value; i.e., 65536 will become 0, 65537 will become 1, and so on.

Note - The current firmware version does not allow the Port Mirroring Status parameter to be set to 'receive' and 'transmit'. Attempting to do so will result in the error message: "The error occurred with 'Set' operation. Error: bad value".

Note - By default, the Port Mirroring Status parameter is set to 'disabled' and the Mirroring Destination Port parameter is set to 0. From this default state, the Port Mirroring Status parameter can be set to 'both' successfully. However, to set the Port Mirroring Status parameter back to 'disabled', the Mirroring Destination Port parameter must be set to a non-zero value.

Note - Any change made to the Mirroring Source Ports parameter while the Mirroring Destination Port parameter is set to 0 will take effect internally but will not be reflected in the MIB variable window. To see the change reflected in the MIB variable window, the Mirroring Destination Port parameter should be set to a non-zero value.

Stacking Menu

From the Stacking menu, you can perform enhanced stacking from any AT-8000 Series master switch.

Stacking Info

Displays information about the switch's mode. This is also the menu where you can perform enhanced stacking.

Note - For the Stack Switch Model parameter, additional characters appear after the model name for discovered AT-8524M, AT-9424T/SP and AT-9424T/GB devices.

Expansion Module Notes

- Device Manager cannot distinguish between the AT-A45/xx, AT-A47, and AT-STCKM expansion modules. All are displayed with the same GIF image.
- When both the AT-A45 and AT-A46 expansion modules are present on a device, the AT-A45 port image may show up as green and its Port Speed parameter may reflect the value "1 Gbps" even if there is no connection established on the port. To reflect the correct port image color and port speed, restart the device. This applies to the following devices:

- AT-8016F/xx
 - AT-8024M
 - AT-8088/xx
-
- The Spanning Tree Protocol (STP) does not work for the AT-A46 expansion module when it is installed on an AT-8016F/ST device. As a result, the Port State parameter of the AT-A46 expansion module port will never be set to 'blocking' and the port image will never turn yellow.
 - Connection between an AT-A47 expansion module port that is configured to operate at 1Gbps full duplex and a port on another device can only be established if the port on the other device is configured to auto-negotiate.
 - For the AT-A47 expansion module, Device Manager will only display the AT-A45/AT-A47/AT-STACKM shared GIF image if a GBIC module is present in the GBIC slot.
 - By default, the Port Speed and Mode parameter of the AT-A47 expansion module port is set to 'auto sense'. From this mode, the Port Speed and Mode can only be changed to '1Gbps full-duplex'. However, once set to '1Gbps full-duplex', it can no longer be set to 'auto sense'.

AT-8000/8POE

This section describes Device Manager menus and operations specific to the AT-8000/8POE switch.

Topics:

- Main Window
- Agent Menu
- Bridge Menu
- RMON Menu
- Port Menu

Main Window

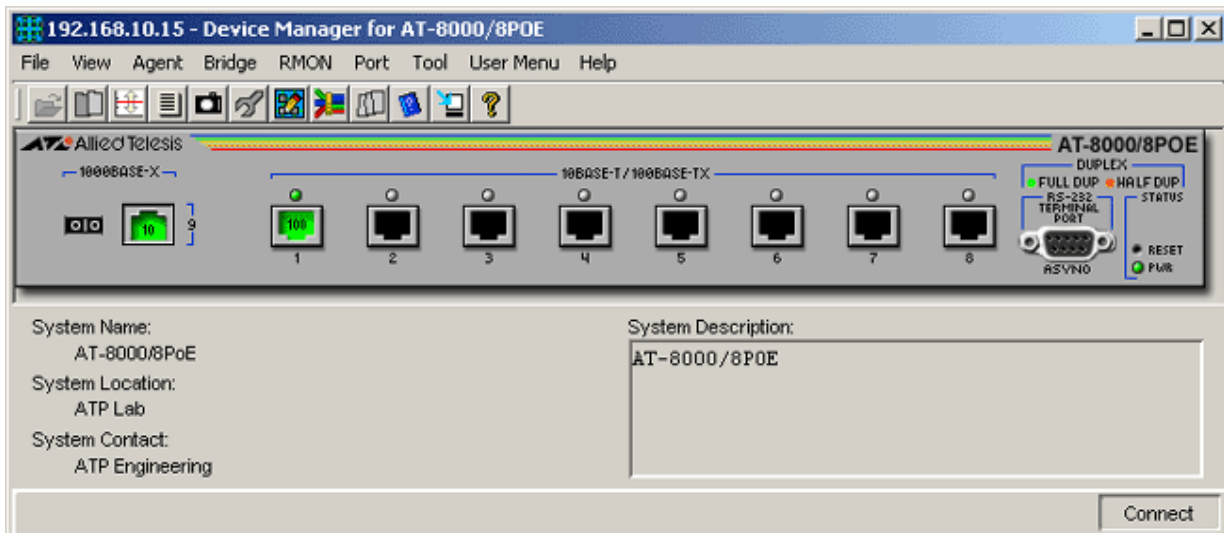

AT-8000/8POE

Device Manager LEDs for AT-8000/8POE		
LED	State	Description
PWR	Green	The switch is receiving power.
DUPLEX	Green	The port is operating at full-duplex mode.
	Orange	The port is operating at half-duplex mode.

Note - The current firmware version does not allow Device Manager to determine whether a port is enabled or disabled. As a result, port images will remain black even if they are actually disabled.

Note - The current firmware version does not allow Device Manager to detect the presence or absence of an SFP module in the SFP slot. As a result, the SFP slot on the device image

will always show an SFP image regardless of whether or not an SFP module is physically present in the slot.

Note - Status information for port 9 will always be reflected on both the RJ-45 port image and the SFP port image regardless of whether it is the RJ-45 or the SFP port that is actually in operation. However, if Device Manager detects that the established link speed is less than 1 Gbps, only the RJ-45 port image will turn green.

Note - When Global RSTP is enabled, the current firmware version sets the Port State parameter of inactive ports to 'blocking'. As a result, expect port images for inactive ports to turn yellow in Device Manager.

Agent Menu

From the Agent menu, you can view and edit the system information for the device, or log into the CLI using Telnet.

System Info

Displays basic system information, including system name, location, contact and description.

Note - The current firmware version accepts anywhere from 1 up to 64 characters for the System Contact, System Name and System Location parameters. NULL values are not accepted.

Firmware Info

Displays firmware version.

Network Info

Displays network-related information such as the addresses of the default gateway and the agents.

Manager Address Info

Displays the IP address of the management station.

Note - The current firmware version does not allow the Trap Destination IP Address parameters to be configured.

DHCP Info

Displays DHCP information including the DHCP System Group and DHCP Timer Group.

Reset

Resets the switch.

Telnet

Starts a Telnet connection to the switch.

WEB Browser

Connects to the switch's HTTP server.

Bridge Menu

From the Bridge menu, you can view and edit bridge information such as the spanning tree status.

Forwarding Database

Displays the Forwarding Database table as returned by the device.

Discard/Aging Time Info

Displays information about the device's aging time.

Spanning Tree Info

Displays spanning tree parameters such as priority and cost.

Note - Values entered for the Root Maximum Aging Time, Root Hello Time and Root Forward Delay Time parameters must be multiples of 100. Values that are not multiples of 100 will be automatically rounded down to the nearest hundreds.

Statistics

Displays statistics about frames received/transmitted on the switch's ports.

Basic Bridge Info

Displays basic bridge information such as the LAN ID, bridge address, number of ports and the bridge type.

Bridge Port Info

Displays basic bridge information on a per port basis such as the LAN ID, port number, circuit, delay exceeded discards and MTU exceeded discards.

Note - The current firmware version returns a NULL value for the Circuit parameter.

RMON Menu

From the RMON menu you can view and edit the RMON MIB.

Statistics

Standard

Displays traffic statistics in the network segment attached to each port.

Note - To collect statistical data on an interface, do the following using a MIB browser tool that allows you to issue an SNMP Set request on a specific table element:

- Set the *etherStatsStatus* (1.3.6.1.2.1.16.1.1.1.21) object to "createRequest(2)"
- Set the *etherStatsDataSource* (1.3.6.1.2.1.16.1.1.1.2) object to the OID of the Ethernet interface to monitor (e.g. 1.3.6.1.2.1.2.2.1.1.1 - Port 1)
- Set the *etherStatsStatus* object to "valid(1)"

Additional Info

Displays additional traffic statistics in the network segment such as frames received/sent, collisions, broadcast frames and multicast frames.

Note - The Deferred Transmissions parameter is not applicable to the AT-8000/8POE and should be ignored.

Error

Displays error statistics in the network segment such as CRC errors, alignment errors, bad frames received late collisions and total transmit errors.

History Control Table

Displays the RMON History table.

Note - To maintain a history of statistics taken at particular intervals for an interface, do the following using a MIB browser tool that allows you to issue an SNMP Set request on a specific table element:

- Set the *historyControlStatus* (1.3.6.1.2.1.16.2.1.1.7) object to "createRequest(2)"
- Set the *historyControlDataSource* (1.3.6.1.2.1.16.2.1.1.2) object to the OID of the Ethernet interface for which historical data will be collected (e.g. 1.3.6.1.2.1.2.2.1.1.1 - Port 1)
- Set the *historyControlStatus* object to "valid(1)"

Alarm Table

Displays the RMON Alarm table.

Event Table

Displays the RMON Event table.

Event Log

Displays the RMON Event log.

Port Menu

From the Port menu, you can view and edit MIB information about the port.

Utilization

Displays the port's utilization information.

Interface Info

Standard

Displays port statistics such as the number of packets received and transmitted on the port, bytes received and transmitted on the port and port status.

Note - The current firmware version returns a NULL value for the Specific Media MIB parameter.

Additional Info

Displays port statistics such as the number of frames received and transmitted on the port, bytes received and transmitted on the port and port status.

Note - The Deferred Transmissions parameter is not applicable to the AT-8000/8POE and should be ignored.

Error Statistics

Displays error statistics.

Detail Info

Displays detailed port information such as duplex mode.

Note - The current firmware version does not return the correct value for the Port State parameter. It also does not allow the parameter to be configured.

Note - The Port Flow Control and Port QoS Priority parameters are not applicable to the AT-8000/8POE and should be ignored.

Spanning Tree Info

Displays the port's spanning tree parameters.

Enable

Enables the port.

Disable

Disables the port.

Port Mirroring

Displays port mirroring parameters and allows configuration of port mirroring state, source and destination.

IGMP Snooping

Displays the current state of IGMP Snooping and allows reconfiguration.

AT-8000GS Series

This section describes Device Manager menus and operations specific to the AT-8000GS Series.

Topics:

- Main Window
- Agent Menu
- Routing Menu
- Bridge Menu
- IGMP Menu
- Security Menu
- RMON Menu
- Port Menu

Main Window

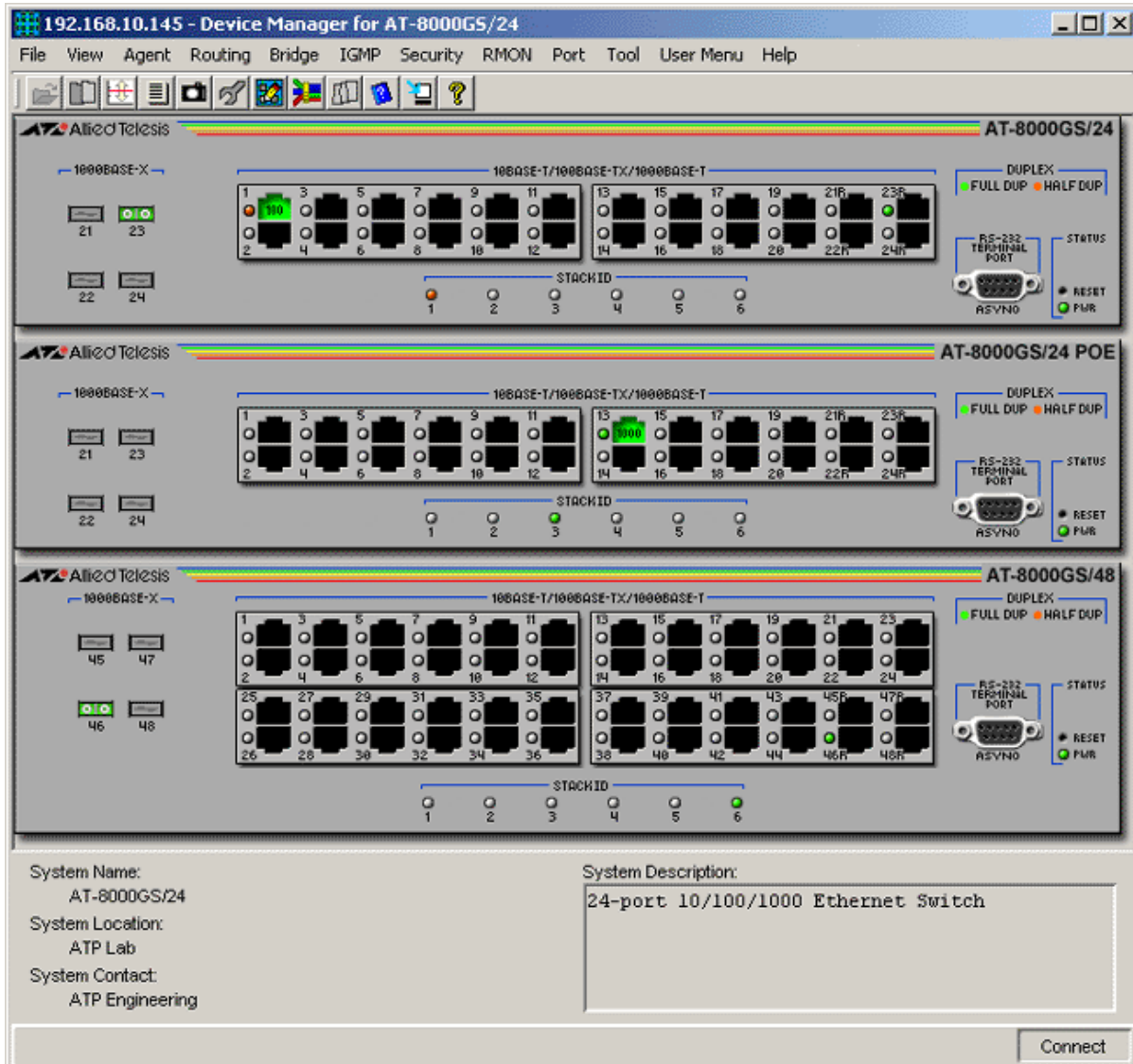

AT-8000GS/24, AT-8000GS/24POE and AT-8000GS/48

The AT-8000GS/24, AT-8000GS/24POE and AT-8000GS/48 can be combined to form a single stack of up to 6 units.

Device Manager LEDs for AT-8000GS Series		
LED	State	Description
PWR	Green	The switch is receiving power.
STACK ID	Orange	The stacked unit is either the Stacking Master or the Backup Master.
	Gray	The switch is a set to standalone mode.
	Green	The stacked unit is a slave switch.

Device Manager LEDs for AT-8000GS Series		
DUPLEX	Green	The port is operating in full-duplex mode.
	Orange	The port is operating in half-duplex mode.

Note - When multiple units of the AT-8000GS series are stacked together, port numbering is continuous based on the Stack Number.

- Stack 1 - 1 to 50
- Stack 2 - 51 to 100
- Stack 3 - 101 to 150
- Stack 4 - 151 to 200
- Stack 5 - 201 to 250
- Stack 6 - 251 to 300

This numbering scheme assumes that a unit can have a maximum of 50 ports.

Note - The current firmware version does not allow Device Manager to detect the presence of an SFP module in any of the SFP slots unless there is an active connection on the SFP ports. As a result, SFP images will appear on the device panel only if there is an established connection on the physical SFP ports.

Note - The current firmware version does not allow Device Manager to handle redundant ports. As a result, the Duplex LED of the copper ports will remain green even if there is an established connection on the equivalent SFP ports.

Agent Menu

From the Agent menu, you can view and edit the system information for the device, or log into the CLI using Telnet.

System Info

Displays basic system information, including system name, location, contact and description.

Note - Valid MIB Set values for the System Name parameter is up to 160 characters.

Note - The current firmware version allows the user to set System Name parameter to NULL.

Device Info

General Info

Displays common management information.

Active Software File

Displays the currently available images on the flash.

Physical Description

Basic Info

Displays the number of stack units.

Module Info

Displays module information for each unit in the system.

Port Attributes

Displays port information.

Stack Info

Displays information about the stacked devices.

Stack Status

Displays the current unit ID and stack mode of the device after reset.

Note - The current firmware version does not allow Device Manager to display the Current Unit ID parameter as a 'read-only' parameter for devices configured in stacked mode.

Note - Valid MIB Set values for the Active Unit ID After Reset parameter is [1-6] inclusive. However, the current firmware version allows the user to set this parameter to '0'.

Power Supply Info

Displays information about the power supply.

Unit General Info

Displays the device's software versions.

Note - Configuring the Serial Number and Asset Tag parameters to any value will cause the device to be inaccessible for approximately 1 minute.

Unit Environment Info

Displays the device's main power supply and temperature status.

Physical Sensors Info

Displays the device's sensor information.

Physical Entity

Displays the information about the device including the serial number.

Note - The current firmware version does not allow Device Manager to display the Serial Number parameter as a 'read-only' parameter.

Note - Valid MIB Set values for the Physical Alias parameter should range from 0 to 32. However, the current firmware version allows the user to enter up to 6 characters only.

Note - Valid MIB Set values for the Physical Asset ID parameter should range from 0 to 32. However, the current firmware version allows the user to enter up to 16 characters only.

POE Info

MCU Info

Displays POE device's Microcontroller information.

POE Config

Displays POE device's configurations.

Note - AT-8000GS/24POE: When multiple units of the AT-8000GS series are stacked together, the current firmware version does not allow the Maximum PSE Power parameter to be configured to 'none' if the Unit ID of the device is '3', '4', '5' or '6'.

Software Packages

Displays the device's software packages.

Management Info

General Management

Displays common management information.

Note - The current firmware does not allow the Reboot Delay parameter to be configured.

Flash File System

Basic Info

Displays the flash file size of the device.

File List

Displays the device's list of files.

File Copy Info

Displays the device's file copy events.

Jumbo Frames

Displays the current jumbo frames status.

Management ACL

Basic Info

Displays basic information about the management access list.

Access Lists

Displays information about access lists.

Mid-level Management

Alarm Options

Displays information about alarm options.

Note - The current firmware version does not allow Alarm Enabling parameter to be configured. Attempting to configure this parameter to any valid value will result in the error "The error occurred with 'Set' operation. Error: noSuchName."

Note - The current firmware version does not allow Row Status parameter to be configured. Attempting to configure this parameter to any valid value will result in the error "The error occurred with 'Set' operation. Error: gen Error."

MIB Tree

Displays information about the device's MIB tree.

Tuning

Agent Diagnostics

Displays diagnostic information about the agent.

Note - The Location parameter is not applicable to the AT-8000GS series and should be ignored.

General Tuning

Displays general tuning information.

Note - Valid MIB Set values for the Debug Level parameter should range from 1-100. However, the current firmware version allows the user to enter values in the range 0-255.

Note - The current firmware version returns inconsistent values when configuring High Priority and Low Priority parameters.

Max Entries Tuning

Displays information about the maximum entries in tuning.

TCP Tuning

Displays the memory pool size for Transmission Control Protocol tuning.

Radius Tuning

Displays the memory pool size for radius tuning.

Syslog Tuning

Displays the current cache size and its size after reset.

Management ACL Tuning

Displays the current number of access rules and the number after reset.

SSH Tuning

Displays the current number of the maximum number of authorized keys and its value after reset.

Terminal Sessions

Displays the current number of maximum sessions and its value after reset.

DNS Client Tuning

Displays the maximum values of the cache entries and the negative cache entries before and after reset.

Tuning Parameters

Displays the current value, value after reset, default value, minimum and maximum value of the different tuning parameters.

Host Parameters

Displays the corresponding value of the different host parameters.

Terminal Debug Mode

Displays the terminal debug mode password.

Note - The current firmware does not allow the Terminal Debug Mode Password parameter to be configured.

Telnet

Basic Info

Displays the basic telnet information.

Note - The current firmware does not allow the Password parameter to be configured.

Telnet Sessions

Displays the login time, client ip address and telnet session status.

CLI Info

Displays information if the file is enabled or not.

Note - The current firmware does not allow the Password parameter to be configured.

Note - The current firmware version does not allow Device Manager to handle 'TruthValues' for the File Enable After Reset parameter. As a result, Device Manager will display integer values of '1' and '2' instead of the value 'True' or 'False' for this parameter.

LCLI Info

Displays information about the device's Telnet sessions and SSH sessions if enabled or not.

Note - Valid MIB Set values for the History Size and SSH History Size parameters should range from 10-206 and 10-210 respectively. However, the current firmware version allows the user to enter values up to 246.

Note - Valid MIB Set values for the Telnet History Size parameter is [10-206] inclusive. However, the current firmware version allows the user to enter values up to 246.

RS-232

Displays the configuration of the baud rate of the device.

Web

Displays the configuration about the HTTP and HTTPS Port the device used.

Note - The current firmware version does not allow the following parameters to be configured:

- Idle Timeout
- HTTP Port
- HTTP Enable
- HTTPS Port
- HTTPS Enable
- HTTPS Active Certificate ID
- Max HTTP Idle Timeout
- Service Protocol

Attempting to configure these parameters to any valid value will result in the error "The error occurred with 'Set' operation.Error:gen Error:".

Note - The current firmware version does not allow the Service Port, Service Certificate and Service Max Idle Timeout parameters to be set to '0', '1000' and '932160' values respectively.

Note - Valid MIB Set values for the Service Certificate ID parameter is [0-1000] inclusive. However, the current firmware version allows the user to enter '-1' and '1001' as its value.

Date and Time

Time Synchronization

Displays the configuration about the device's date/time and time zone.

Note - Valid MIB Set values for the DST Offset parameter should range from 1-1440. However, the current firmware version allows the user to enter values outside of the valid range and negative values as well.

Note - The current firmware version does not allow DST Start and DST End parameters to be configured when the DST Mode is set to 'recurring' or 'date' value.

Note - The current firmware version does not allow Device Manager to display the Managed Time parameter in a 12hour format.

Note - Valid MIB Set values for the Time Zone Code and DST Code parameters are up to 4 characters. However, the current firmware version allows the user to enter up to 16 characters.

SNTP/NTP Client Config

Displays information about SNTP/NTP client configuration.

Note - Valid MIB Set values for the Polling Interval parameter should range from 60-86400. However, the current firmware version allows the user to enter values outside of the valid range and negative values as well.

SNTP Config

Displays information about SNTP client configuration.

Broadcast Mode

Displays information about broadcast mode per interface.

SNTP Server Info

Displays information about trusted SNTP servers to be queried in unicast or broadcast mode.

Note - Valid MIB Set values for the Key Identifier parameter is [1-4294967295] inclusive. However, the current firmware version allows the user to enter the value '0'.

Authentication Keys

Displays information about keys information for authentication of NTP packets.

Note - The Key ID parameter is implemented as 'read-only'.

System Log

Basic Info

Displays information and configuration of the device's log files.

Note - The current firmware version does not allow Clear Log File and Clear Cache parameters to be configured.

Event Log

Displays information about events sent to the system log file.

Error Log

Displays information about errors registered to the system cache.

Syslog Device

Displays information about Syslog diagnostic messages.

Note - The current firmware version does not allow the Syslog Device Control parameter to be configured.

Syslog Collector

Displays the information to generate syslog messages to an aggregating agent or collector.

Syslog Application

Displays information about a managed entity that provides individual control over the severity level of the messages that it will generate.

Note - The current firmware version does not allow Severity parameter to be configured.

Reset

Resets the switch.

Telnet

Starts a Telnet connection to the switch.

WEB Browser

Connects to the switch's HTTP server.

Routing Menu

From the Routing menu, you can view and edit information about the switch's routing functions.

IP

ARP Table

Displays the Address Resolution Protocol cache on the switch.

Note - The current firmware version does not allow Physical Address parameter to be configured. Attempting to configure this parameter to any valid value will result in the error "The error occurred with 'Set' operation. Error. bad value."

Note - The current firmware version does not allow Mapping Type parameter to be configured. Attempting to configure this parameter from 'static' to 'dynamic' value will result in the error "The error occurred with 'Set' operation. Error. bad value."

Note - The current firmware version does not allow Mapping Type parameter to be set to 'invalid' or 'other' as its value.

Address Table

Standard

Displays the list of IP interfaces on the switch.

Additional Info

Displays additional information about the address table.

Note - The Backup Address parameter is not applicable to the AT-8000GS series and should be ignored.

Note - The current firmware version does not allow the IP Interface Owner parameter to be configured. Attempting to configure this parameter to any valid value will result in the error "The error occurred with 'Set' operation. Error. bad value."

Note - Configuring the Port Number parameter will cause the device to be inaccessible and may need the restarted.

Static Route Table

Displays the IP static routing table.

Note - The current firmware version does not allow Routing Type parameter to be set to 'local' as its value.

Note - Configuring the Destination Metric and Next Hop AS Number parameters to invalid values will automatically set the entered values to valid values.

IP Statistics

Displays statistics about IP routing, including the number of IP datagrams received.

Note - The current firmware version does not allow Forwarding Status parameter to be configured. Attempting to configure this parameter to any valid value will result in the error "The error occurred with 'Set' operation. Error. bad value."

ARP Table Config

Displays configuration information about Address Resolution Protocol.

Note - The current firmware version does not allow Unresolve Timer parameter to be configured. Attempting to configure this parameter to any valid value will result in the error "The error occurred with 'Set' operation. Error. bad value."

I/F Name-Address Translation

Displays information about the IP interface's name translated to an IP interface address.

TFTP

Displays configuration information about the TFTP.

Note - The current firmware version does not allow the Send Config File parameter to be configured.

Note - Configuring the Get Config File parameter will cause the device to reboot and reset its running configuration to default configuration.

Note - The current firmware version does not allow the File Server IP Address parameter to be configured.

Note - Configuring the Retry Timeout and Total Timeout parameters to invalid values will automatically set the entered values to valid values.

UDP

Listener Info

Displays User Datagram Protocol listener information.

UDP Statistics

Displays User Datagram Protocol statistics.

TCP

Connection Info

Displays Transmission Control Protocol connection-specific information.

Note - The current firmware version does not allow Connection Status parameter to be configured. Attempting to configure this parameter to any valid value will result in the error "The error occurred with 'Set' operation. Error: gen Error."

TCP Statistics

Displays Transmission Control Protocol statistics.

CIDR

Route Number

Displays the number of valid Classless Inter-Domain Routing entries.

Route Table

Displays the Classless Inter-Domain Routing routing tables.

Note - The current firmware version does not allow Routing Type parameter to be configured. Attempting to configure this parameter to any valid value will result in the error "The error occurred with 'Set' operation. Error: bad value."

Note - The current firmware version does not allow the following parameters to be configured:

- Destination Port Number

- Routing Protocol MIB
- Destination Metric 2
- Destination Metric 3
- Destination Metric 4
- Destination Metric 5

Note - The current firmware version only allows the Routing Type parameter to be set to 'reject' if the value prior to set operation is 'remote'.

ICMP

ICMP Statistics

Displays Internet Control Message Protocol Statistics.

Error Messages

Displays the variable that controls the ability to generate Internet Control Message Protocol error messages.

DHCP Info

Basic Info

Displays DHCP information.

Snooping

Displays the system's DHCP Snoop information.

Note - The current firmware version does not allow the Clear Action parameter to be set to 'noAction' as its value.

DNS Resolver

Resolver Config

Displays information about the Domain Name System client.

Note - The current firmware version does not allow the Reset parameter to be configured to 'reset' as its value. Attempting to configure this parameter to any valid value will result in the error "The error occurred with 'Set' operation. Error. bad value.".

Basic Counters

Displays information about basic Domain Name System counters.

Counters by OpCode

Displays information about the current count of resolver queries and answers.

Counters by Response Code

Displays information about the current count of responses to resolver queries.

Lame Delegation Overflows

Displays information about number of times the resolver attempted to add an entry to the lame delegation table.

Cache Info

Displays information about a collection of objects providing access to and control of a Domain Name System resolver's cache.

Negative Cache Info

Displays information about a collection of objects providing access to and control of a Domain Name System resolver's negative response cache.

Additional Counters

Displays information about a collection of objects providing further instrumentation applicable to many but not all Domain Name System resolvers.

Bridge Menu

From the Bridge menu, you can view and edit bridge information such as the forwarding database and the spanning tree status.

Forwarding Database

Standard View

Displays the Forwarding Database table as returned by the device.

Enhanced View

Displays the Forwarding Database table on a per port basis. User can select a port or group of ports to view its corresponding Forwarding Database entries.

Aging Time Info

Displays information about the device's aging time.

Spanning Tree Info

STP

Standard

Displays the spanning tree information such as the STP version and path cost.

Note - Valid MIB Set values for the Priority parameter is [0-65535] inclusive. However, attempting to set this parameter to any value beyond 61440 will result in the error "The error occurred with 'Set' operation. Error. bad value."

Additional Info

Displays additional Spanning Tree Protocol information like supported type.

Note - The current firmware version does not allow the Flood BPDU Method parameter to be set to 'bridging' as its value.

Note - The current firmware version does not allow Device Manager to handle 'TruthValues' for the STP Enable and Filter BPDU parameters. As a

result, Device Manager will display integer values of '1' and '2' instead of the value 'True' or 'False' for this parameter.

MSTP

Basic Info

Displays the basic information about Multiple Spanning Tree Protocol.

Instance Info

Displays information that contains Multiple Spanning Tree Protocol instance specific information for the Multiple Spanning Tree Protocol.

Statistics

Displays statistics about frames received/transmitted on the switch port.

Basic Bridge Info

Displays basic bridge information.

Bridge Port Info

Displays statistics about frames received/transmitted on the switch port.

Note - The current firmware version does not allow the Number of Traffic Class parameter to be configured. Attempting to configure this parameter to any valid value will result in the error "The error occurred with 'Set' operation. Error. bad value."

802.1p

Device Capabilities

Displays information on the device capabilities.

Port Priority Group

Displays information about the port priority.

Traffic Class

Displays information about the traffic class and traffic class priority.

Note - Valid MIB Set values for the Received Traffic Class parameter is [0-7] inclusive. However, the current firmware version does not allow this parameter to be set to 4-7 as its value.

MAC Table Info

Displays MAC table information.

Note - The current firmware version does not allow Device Manager to handle 'TruthValues' for the Trap Enable parameter. As a result, Device Manager will display integer values of '1' and '2' instead of the value 'True' or 'False' for this parameter.

MAC Base Priority Support

Displays MAC Base priority support.

IGMP Menu

From the IGMP menu, you can view and edit Internet Group Management Protocol information such as IGMP queries and reports sent between devices and interfaces on which IGMP is enabled.

MAC Multicast Info

Displays configurations of the enabling/disabling multicast.

IGMP Config

Displays configurations of the Internet Group Management Protocol function.

Security Menu

From the Security menu, you can view and edit different security and authentication protocols SSL, SSH, and port-based authentication.

Authentication/Authorization/Accounting

Basic Info

Displays basic information about Authentication/Authorization/Accounting.

Note - The current firmware version does not allow the EAP Current Method List parameter to be configured. Attempting to configure this parameter to any valid value will result in the error "The error occurred with 'Set' operation. Error: gen error".

Method Lists

Displays information about all method lists.

Note - The current firmware version does not allow the Row Status parameter to be set to 'create and go' or 'destroy' as its value.

Lines

Displays information about all lines, their passwords and their authorization levels.

Note - The current firmware version does not allow Row Status parameter to be configured. Attempting to configure this parameter to any valid value will result in the error "The error occurred with 'Set' operation. Error: gen Error".

Note - The current firmware version does not allow the following parameters to be configured on the implemented data type and range:

- Method List Name Level 1
- Method List Name Level 2
- Method List Name Level 3
- Method List Name Level 4
- Method List Name Level 5

- Method List Name Level 6
- Method List Name Level 7
- Method List Name Level 8
- Method List Name Level 9
- Method List Name Level 10
- Method List Name Level 11
- Method List Name Level 12
- Method List Name Level 13
- Method List Name Level 14
- Method List Name Level 15

As a result, it will display the values: 'enable_n_default', 'enable_c_default', 'login_n_default', 'login_c_default', 'http', 'https' and 'null' as valid values instead of allowing the user to enter up to 20 characters for these parameters.

Note - The current firmware version does not allow the Password Valid Time parameter to be configured.

Local Users

Displays information about all usernames, their passwords and their authorizations.

Note - The current firmware version does not allow the Password Valid Time parameter to be configured.

Authenticated Users

Displays all the current users that have been authenticated.

EAP Method Lists

Displays information about all Extensible Authentication Protocol method lists.

Note - The current firmware version does not allow the Row Status parameter to be set to 'create and go' or 'destroy' as its value.

Password Verification

Displays the system's password configurations.

Note - The current firmware version does not allow the Old Password, New Password and Confirm Password parameters to be configured if the values for these parameters were initially configured using CLI.

Port-based Authentication

PAE Port Info

Displays the system level information for each port supported by the Port Access Entity.

Authenticator PAE Info

Displays configuration objects for the Authenticator Port Access Entity associated with each port.

Note - The current firmware version does not allow Administrative Controlled Directions parameter to be set to 'in' and Key Transmission Status parameter to 'true' as its value.

Authenticator PAE Statistics

Displays statistics objects for the Authenticator Port Access Entity associated with each port.

Authenticator PAE Diagnostics

Displays diagnostics objects for the Authenticator Port Access Entity associated with each port.

Authenticator PAE Session Statistics

Displays session statistics objects for the Authenticator Port Access Entity associated with each port.

Note - The current firmware version returns a 'noSuchName' value for the following parameters:

- Received Octets
- Transmitted Octets
- Received Frames
- Transmitted Frames

Note - The current firmware version does not allow Device Manager to display values for the User Name parameter.

RADIUS

Basic Info

Displays basic RADIUS information.

RADIUS Server Info

Displays the IP address, User Datagram Protocol port number for authentication and accounting request, and current status of the RADIUS server.

Note - The current firmware version does not allow Usage parameter to be set to 'wireless authentication' as its value.

Authentication Client Info

Displays the number of RADIUS Access-Response packets received from unknown addresses and the identifier of the RADIUS authentication client.

Authentication Server Info

Displays the list of RADIUS authentication servers with which the client shares a secret.

Accounting Client Info

Displays the number of RADIUS Access-Response packets received from unknown addresses and the identifier of the RADIUS accounting client.

Accounting Server Info

Displays the list of RADIUS accounting servers with which the client shares a secret.

TACACS+

Basic Info

Displays basic TACACS+ information.

TACACS+ Server Info

Displays information about TACACS+ server.

Secure Shell

SSH Server

Displays information about the status of public key authentication and the type of regenerated host key.

Note - Configuring the Regenerate Host Key parameter to 'rsa', 'dsa' or 'rsa1' values will result to an error message "time out occurred." but the value is successfully set. Moreover, after the set operation, attempting to view this table will display the following 'read-only' parameters and should be ignored:

- Server Host Public Key Algorithm
- Server Host Public Key Fragment ID
- Server Host Public Key Fragment Text
- Server Host Public Key Fingerprint Algorithm
- Server Host Public Key Fingerprint Algorithm
- Server Host Public Key Fingerprint Digest Format
- Server Host Public Key Fingerprint

Note - The current firmware version does not allow the Regenerate Host Key parameter to be set to 'rsa1' as its value.

SSH Client

Displays information about the user name ssh client will use and the value of the regenerated self key.

Note - Valid MIB Set values for the User Name parameter should range from 1-48. However, the current firmware version allows the user to enter values in the range 0-160.

Note - The current firmware version does not allow the Regenerate Self Key parameter to be set to 'rsa1' as its value.

Note - Configuring the Regenerate Self Key parameter to 'rsa' or 'dsa' as its value will cause the device to be inaccessible and may need the restarted.

Secure Socket Layer

Basic Info

Displays basic SSL information.

Certificate Generation

Displays information about the generated keys and self signed certificates.

Note - The current firmware version does not allow the following parameters to be configured:

- Certificate Generation ID
- Country Name
- State or Province Name
- Locality
- Organization Name
- Organization Unit Name
- Common Name
- Valid Days
- RSA Key Length
- Passphrase

Attempting to configure these parameters to any valid value will result in the error "The error occurred with 'Set' operation. Error: time out occurred."

Note - The Certificate Generation Index parameter is implemented as 'read-only'.

Note - The current firmware version does not allow Action parameter to be configured.

Export Certificate

Displays information about the saved data from Random Access Memory and flash.

Import Certificate

Displays information about the copied external certificate of the device.

Note - The current firmware version does not allow Fragment Text parameter to be configured. Moreover, attempting to configure this parameter followed by Refresh operation will display numeric values.

RMON Menu

From the RMON menu, you can view and edit the RMON MIB.

Statistics

Displays traffic statistics in the network segment attached to each port.

History Control Table

Displays the RMON History table.

Alarm Table

Displays the RMON Alarm table.

Event Table

Displays the RMON Event table.

Event Log

Displays the RMON Event log.

Port Menu

From the Port menu, you can view and edit MIB information about the port.

Utilization

Displays the port's utilization information.

Note - The current firmware version does not allow Device Manager to display the Port Number parameter for single port.

Note - The current firmware version does not allow Device Manager to display Utilization information.

Interface Info

Standard

Displays port statistics such as the number of frames received and transmitted on the port, bytes received and transmitted on the port, and port status.

Note - The current firmware version returns a 'noSuchName' value for the following parameters:

- Transmitted Buffer Length
- Received Unicast Packets (HC)
- Received Multicast Packets (HC)
- Received Broadcast Packets (HC)
- Transmitted Unicast Packets (HC)
- Transmitted Multicast Packets (HC)
- Transmitted Broadcast Packets (HC)

Note - The current firmware version does not allow the Promiscuous Mode parameter to be set to 'false' as its value.

Additional Info

Displays additional information about the port's interface info.

Test Interface

Displays port's test information.

Note - The current firmware version does not allow the Test Set Type parameter to be configured. Attempting to configure this parameter to any valid value will result in the error "The error occurred with 'Set' operation. Error. bad value."

Error Statistics

Note - The Ethernet Chip Set parameter is not applicable to the AT-8000GS series and should be ignored.

Note - The current firmware version returns a 'noSuchName' value for the following parameters:

- Alignment Error Frames
- Multi Collision Frames
- SQE Test Errors
- Deferred Transmissions
- Carrier Sense Errors
- Symbol Errors

Detail Info

Displays detailed port information such as duplex mode.

Note - The Physical Address Type parameter is not applicable to the AT-8000GS series and should be ignored.

Note - The current firmware version does not allow the following parameters to be configured:

- Tagged Mode
- Default Priority
- Row Status
- Port Flow Control Config
- Port Speed
- Reactive and Combo Ethernet Config

Attempting to configure these parameters to any valid value will result in the error "The error occurred with 'Set' operation. Error. bad value." except for the Default Priority parameter.

Note - The current firmware version does not allow the Host Mode parameter to be set to 'multiple-auth' as its value.

Note - The current firmware version does not allow the Autonegotiation Capabilities Config parameter to be configured. Attempting to configure this parameter to any

valid value will result in the error "The error occurred with 'Set' operation. Error. bad value."

POE Port Status

Displays port's POE information.

Note - Valid MIB Set values for the Port Power Limit parameter is [0 - 2147483647]. However, the current firmware version does not allow this parameter to be configured to any value. Attempting to configure this parameter from 15401-2147483647 will result in the error "The error occurred with 'Set' operation. Error: gen error".

Spanning Tree Info

STP

Standard

Displays the port's spanning tree parameters.

Additional Info

Displays a list of information maintained by every port about the Spanning Tree Protocol state for that port.

Note - The current firmware version does not allow Device Manager to handle 'TruthValues' for the following parameters:

- Dampening Enable
- Filter BPDU
- Restricted Role
- Auto Edge Port

As a result, Device Manager will display integer values of '1' and '2' instead of the value 'True' or 'False' for these parameters.

MSTP

MSTI

Displays a list of information maintained by every pair <msti, port> about the Spanning Tree Protocol state for that pair.

CIST

Displays a list of information maintained by every port of the CIST.

Enable

Enables the port.

Disable

Disables the port.

Port Lock

Basic Info

Displays basic information about port lock.

Interfaces Range

Displays information about port lock interfaces range.

Note - The current firmware version does not allow Range parameter to be configured. Moreover, attempting to configure this parameter followed by Refresh operation will display numeric values.

MAC Control

MAC Control Sublayer

Displays information about the MAC Control sublayer on a single ethernet-like interface.

Note - The current firmware version returns a 'noSuchName' value for Unknown OpCodes Received and Unknown OpCodes Received (HC) parameters.

MAC Control PAUSE

Displays information about the MAC Control PAUSE function on a single ethernet-like interface.

Note - The current firmware version returns a 'noSuchName' value for the Received Frames (HC) and Transmit Frames (HC) parameters.

Note - The current firmware version does not allow the PAUSE Config parameter to be set to 'enabledXmit' or 'enabledRcv' as its value.

Port Trunking

Basic Info

Displays basic information about port trunking.

Note - The current firmware version does not allow the Trunk Creation Support and LACP Membership Restrictions Support parameters to be configured.

Balancing Criteria

Displays information about Aggregate Index.

Note - The current firmware version does not allow the Used Addresses and Broadcast Type parameters to be configured.

Aggregator Info

Displays information about every Aggregator that is associated with this system.

Note - Valid MIB Set values for the Actor Administrative Key parameter is [1-65535] inclusive.

Aggregator Port List

Displays Link Aggregation Control information for every Aggregation Port associated with this device.

Aggregation Port Info

Displays a list of Link Aggregation Control configuration parameters for each Aggregation Port on this device.

Note - The current firmware version does not allow the Actor Administrative Key and Partner Administrative System ID parameters to be configured. Attempting to configure these parameters to any valid value will result in the error "The error occurred with 'Set' operation. Error. bad value."

Note - Device Manager does not handle 8-bit string parameters correctly. As a result, the Actor Administrative Status and Partner Administrative Status parameters will display unrecognizable values and will not be configurable.

Storm Control

Basic Info

Displays basic information about storm control.

Storm Control Protection

Displays information about the storm control protection per port.

Note - The current firmware version does not allow the following parameters to be configured:

- Rate Type
- Unknown Unicast Rate
- Unknown Multicast Rate
- Broadcast Rate
- Multicast Rate

Note - The current firmware version does not allow Device Manager to handle 'TruthValues' for the following parameters:

- Unknown Unicast Enable
- Unknown Multicast Enable
- Broadcast Enable
- Multicast Enable
- Set Default Rate Type
- Set Default Unknown Unicast Enable
- Set Default Unknown Unicast Rate
- Set Default Unknown Multicast Enable
- Set Default Unknown Multicast Rate
- Set Default Broadcast Enable
- Set Default Broadcast Rate

- Set Default Multicast Enable
- Set Default Multicast Rate

As a result, Device Manager will display integer values of '1' and '2' instead of the value 'True' or 'False' for these parameters.

Storm Control Group

Displays information about group id for each supported frame type defined per port.

AT-8000GS Series

AT-8000S Series

This section describes Device Manager menus and operations specific to the AT-8000S Series.

Topics:

- Main Window
- Agent Menu
- Routing Menu
- Bridge Menu
- IGMP Menu
- Security Menu
- RMON Menu
- Port Menu

Main Window

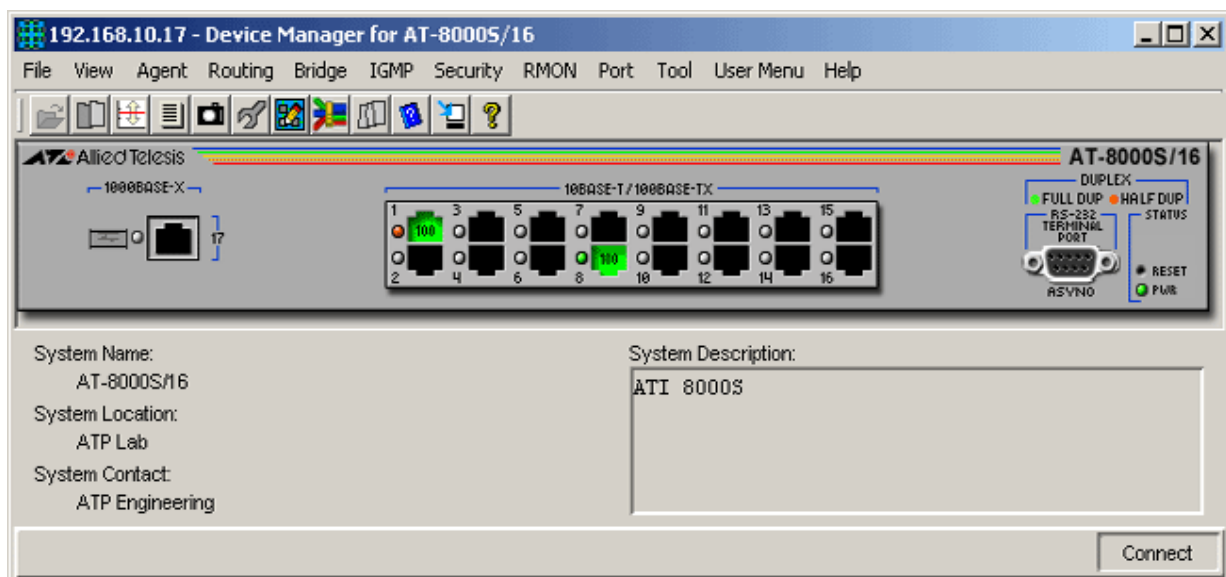

AT-8000S/16

AT-8000S/24, AT-8000S/48 and POE Models

The AT-8000S/24, AT-8000S/24POE, AT-8000S/48 and AT-8000S/48POE can be combined to form a single stack of up to 6 units.

Device Manager LEDs for AT-8000S Series		
LED	State	Description
PWR	Green	The switch is receiving power.
STACK ID	Orange	The stacked unit is either the Stacking Master or the Backup Master.
	Gray	The switch is a set to standalone mode.
	Green	The stacked unit is a slave switch.
DUPLEX	Green	The port is operating in full-duplex mode.
	Orange	The port is operating in half-duplex mode.

Note - When multiple units of the AT-8000S series are stacked together, port numbering is continuous based on the Box ID.

- Box ID 1 - 1 to 54
- Box ID 2 - 55 to 108
- Box ID 3 - 109 to 162
- Box ID 4 - 163 to 216
- Box ID 5 - 217 to 270
- Box ID 6 - 271 to 324

This numbering scheme assumes that a unit can have a maximum of 54 ports.

Combo ports on the AT-8000S/24 and AT-8000S/24POE devices are assigned port numbers 49 and 50.

Note - The current firmware version does not allow Device Manager to detect the presence of an SFP module in any of the SFP slots unless there is an active connection on the SFP ports. As a result, SFP images will appear on the device panel only if there is an established connection on the physical SFP ports.

Agent Menu

From the Agent menu, you can view and edit the system information for the device, or log into the CLI using Telnet.

System Info

Displays basic system information, including system name, location, contact and description.

Note - The current firmware version accepts up to 160 characters for the System Name parameter.

Device Info

General Info

Displays common management information.

Active Software File

Displays the currently available images on the flash.

Physical Description

Basic Info

Displays the number of stack units.

Module Info

Displays module information for each unit in the system.

Port Attributes

Displays port information.

Stack Info

Displays information about the stacked devices.

Stack Active Unit ID

Displays the current unit ID of the device after reset.

Note - AT-8000S/16: The current firmware version allows the Active Unit ID After Reset parameter to be configured but the value is not saved after it is rebooted.

Power Supply Info

Displays information about the power supply and redundant power supply.

Fan Info

Displays fan status.

Unit General Info

Displays the device's software versions.

Note - The current firmware version accepts up to 160 characters for the Serial Number and Asset Tag parameters but truncates them to 31 and 16 characters respectively.

Note - The current firmware version is unable to display any value for the Service Tag parameter.

Unit Environment Info

Displays the device's main power supply and temperature status.

Software Packages

Displays the device's software packages.

Management Info

General Management

Displays common management information.

Flash File System

Basic Info

Displays the flash file size of the device.

File List

Displays the device's list of files.

Note - The current firmware version does not allow the Row Status parameter to be configured.

Jumbo Frames

Displays the current jumbo frames status.

Management ACL

Basic Info

Displays basic information about the management access list.

Note - The current firmware version does not allow the Active List Name parameter to be configured.

Access Lists

Displays information about access lists.

Mid-level Management

Alarm Options

Displays information about alarm options.

Note - The current firmware version does not allow the Alarm Enabling parameter to be configured.

MIB Tree

Displays information about the device's MIB tree.

Tuning

Agent Diagnostics

Displays diagnostic information about the agent.

Note - The current firmware version returns a 'noSuchName' value for the Location parameter.

General Tuning

Displays general tuning information.

Note - The current firmware version accepts values in the range [0-255] inclusive for the Debug Level parameter.

Max Entries Tuning

Displays information about the maximum entries in tuning.

Note - The current firmware version does not allow the following parameters to be configured:

- Max IP Next Hop Entries After Reset
- Max IP Prefixes After Reset
- Max IP ECMP Entry After Reset
- Max IP Interfaces After Reset

TCP Tuning

Displays the memory pool size for tcp tuning.

Radius Tuning

Displays the memory pool size for radius tuning.

Syslog Tuning

Displays the current cache size and its size after reset.

Management ACL Tuning

Displays the current number of access rules and the number after reset.

SSH Tuning

Displays the current number of the maximum number of authorized keys and its value after reset.

Terminal Sessions

Displays the current number of maximum sessions and its value after reset.

DNS Client Tuning

Displays the maximum values of the cache entries and the negative cache entries before and after reset.

Tuning Parameters

Displays the current value, value after reset, default value, minimum and maximum value of the different tuning parameters.

Host Parameters

Displays the corresponding value of the different host parameters.

Terminal Debug Mode

Displays the terminal debug mode password.

Note - The current firmware version does not allow the Terminal Debug Mode Password to be configured.

Telnet

Basic Info

Displays the basic telnet information.

Telnet Sessions

Displays the login time, client ip address and telnet session status.

CLI Info

Displays information if the file is enabled or not.

LCLI Info

Displays information about the device's Telnet sessions and SSH sessions if enabled or not.

Note - Valid MIB Set values for the History Size, Telnet History Size and SSH History Size parameters are in the range [10-160] inclusive. Attempting to set these parameters to a value outside of the valid range will result in the error message: "The error occurred with 'Set' operation. Error: bad value."

RS-232

Displays the configuration of the baud rate of the device.

Web

Displays the configuration about the HTTP and HTTPS Port the device used.

Date and Time

Time Synchronization

Displays the configuration about the device's date/time and time zone.

Note - The current firmware version does not allow the Managed Time and Managed Date parameters to be configured.

Note - Device Manager always treats objects of type OCTET STRING as a sequence of bytes in hexadecimal format and does not convert them to plain text format when necessary. As a result, the DST End and the DST Start parameters will neither be readable nor configurable.

Note - Valid MIB Set values for the DST Offset parameter should range from 1 to 1440. However, the current firmware version allows the user to enter values in the range [-2147483648 to 2147483647] inclusive. Attempting to enter values greater than 2147483647 will cause the new value to be converted to its equivalent wrap-around value; i.e., 2147483648 will become -2147483648, 2147483649 will become -2147483647, and so on.

SNTP/NTP Client Config

Displays information about SNTP/NTP client configuration.

Note - Valid MIB Set values for the Polling Interval parameter should range from 60 to 86400. However, the current firmware version allows the user to enter values in the range [-2147483648 to 2147483647] inclusive. Attempting to enter values greater than 2147483647 will cause the new value to be converted to its equivalent wrap-around value; i.e., 2147483648 will become -2147483648, 2147483649 will become -2147483647, and so on.

SNTP Config

Displays information about SNTP client configuration.

Note - The current firmware version returns a 'noSuchName' value for the Broadcast Poll State and Anycast Poll State parameters.

Broadcast Mode

Displays information about broadcast mode per interface.

SNTP Server Info

Displays information about trusted SNTP servers to be queried in unicast or broadcast mode.

Authentication Keys

Displays information about keys information for authentication of NTP packets.

System Log

Basic Info

Displays information and configuration of the device's log files.

Note - Setting the Clear Log File and Clear Cache parameters to a value other than 0 will delete the log file and clear the cache memory but the value used will not be retained.

Event Log

Displays information about events sent to the system log file.

Error Log

Displays information about errors registered to the system cache.

Syslog Device

Displays information about Syslog diagnostic messages.

Note - Device Manager does not handle 8-bit string parameters correctly. As a result, the Syslog Device Control parameter will display the string "00000000" and will not be configurable.

Syslog Collector

Displays the information to generate syslog messages to an aggregating agent or collector.

Syslog Application

Displays information about a managed entity that provides individual control over the severity level of the messages that it will generate.

Note - The current firmware version does not allow the Severity parameter to be configured.

Reset

Resets the switch.

Telnet

Starts a Telnet connection to the switch.

WEB Browser

Connects to the switch's HTTP server.

Routing Menu

From the Routing menu, you can view and edit information about the switch's routing functions.

IP

ARP Table

Displays the ARP cache on the switch.

Address Table

Standard

Displays the list of IP interfaces on the switch.

Additional Info

Displays additional information about the address table.

Note - The current firmware version does not allow the IP Interface Owner parameter to be configured.

Note - The Backup Address parameter is not applicable to the AT-8000S module and should be ignored.

Static Route Table

Displays the IP static routing table.

Note - The current firmware version does not allow the Routing Type parameter to be set to 'local' for all models except the AT-8000S/I6. For the AT-8000S/I6, the Routing Type parameter cannot be set to 'remote.'

IP Statistics

Displays statistics about IP routing, including the number of IP datagrams received.

Note - The current firmware version does not allow the Forwarding Status parameter to be configured.

ARP Table Config

Displays configuration information about ARP.

I/F Name-Address Translation

Displays information about the IP interface's name translated to an IP interface address.

TFTP

Displays configuration information about the TFTP.

Note - The current firmware version does not allow the Get Config File parameter to be configured to receive image/config/boot files from a TFTP server.

Note - The current firmware version does not allow the Send Config File parameter to be configured to send config/image/boot files to a TFTP server.

UDP

Listener Info

Displays UDP listener information.

UDP Statistics

Displays UDP statistics.

TCP

Connection Info

Displays TCP connection-specific information.

Note - The current firmware version does not allow the Connection Status parameter to be configured.

TCP Statistics

Displays TCP statistics.

CIDR

Route Number

Displays the number of valid CIDR entries.

Route Table

Displays the CIDR routing tables.

Note - The current firmware version does not allow the following parameters to be configured:

- Destination Port Number
- Routing Protocol MIB
- Destination Metric 2
- Destination Metric 3
- Destination Metric 4
- Destination Metric 5

Note - The current firmware version does not allow the Routing Type parameter to be set to 'local' for all models except the AT-8000S/I6. For the AT-8000S/I6, the Routing Type parameter cannot be set to 'remote'.

ICMP

ICMP Statistics

Displays ICMP Statistics.

Error Messages

Displays the variable that controls the ability to generate ICMP error messages.

DNS Resolver

Resolver Config

Displays information about the DNS client.

Note - The current firmware version does not allow the Reset parameter to be set to "reset".

Basic Counters

Displays information about basic DNS counters.

Counters by OpCode

Displays information about the current count of resolver queries and answers.

Counters by Response Code

Displays information about the current count of responses to resolver queries.

Lame Delegation Overflows

Displays information about number of times the resolver attempted to add an entry to the lame delegation table.

Cache Info

Displays information about a collection of objects providing access to and control of a DNS resolver's cache.

Negative Cache Info

Displays information about a collection of objects providing access to and control of a DNS resolver's negative response cache.

Additional Counters

Displays information about a collection of objects providing further instrumentation applicable to many but not all DNS resolvers.

Bridge Menu

From the Bridge menu, you can view and edit bridge information such as the forwarding database and the spanning tree status.

Forwarding Database

Standard View

Displays the Forwarding Database table as returned by the device.

Enhanced View

Displays the Forwarding Database table on a per port basis. User can select a port or group of ports to view its corresponding Forwarding Database entries.

Aging Time Info

Displays information about the device's aging time.

Spanning Tree Info

STP

Standard

Displays the spanning tree information such as the STP version and path cost.

Additional Info

Displays additional STP information like supported type.

MSTP

Basic Info

Displays the basic information about MSTP.

Instance Info

Displays information that contains Mstp instance specific information for the Multiple Spanning Tree Protocol.

VLAN Info

Displays information about the allocation of vlans to groups.

Statistics

Displays statistics about frames received/transmitted on the switch port.

Basic Bridge Info

Displays basic bridge information.

Bridge Port Info

Displays statistics about frames received/transmitted on the switch port.

Note - The current firmware version does not allow the Number of Traffic Class parameter to be configured.

802.1p

Device Capabilities

Displays information on the device capabilities.

Port Priority Group

Displays information about the port priority.

Traffic Class

Displays information about the traffic class and traffic class priority.

Note - Valid MIB Set values for the Traffic Class parameter are in the range [0-3] inclusive. Attempting to set this parameter to a value outside of the valid range will result in the error message: "The error occurred with 'Set' operation. Error: bad value."

MAC Table Info

Displays MAC table information.

IGMP Menu

From the IGMP menu, you can view and edit IGMP information such as IGMP queries and reports sent between devices, VLAN's IGMP functions and interfaces on which IGMP is enabled.

MAC Multicast Info

Displays configurations of the enabling/disabling multicast.

IGMP Config

Displays configurations of the Internet Group Management Protocol function.

VLAN Info

Displays configurations of the VLAN information.

Security Menu

From the Security menu, you can view and edit different security and authentication protocols SSL, SSH, and port-based authentication.

Authentication/Authorization/Accounting

Basic Info

Displays basic information about Authentication/Authorization/Accounting.

Note - The current firmware version does not allow the EAP Current Method List parameter to be configured.

Method Lists

Displays information about all method lists.

Note - The current firmware version does not allow the Row Status parameter to be configured.

Lines

Displays information about all lines, their passwords and their authorization levels.

Note - The current firmware version does not allow the Password, Row Status and Password Valid Time parameters to be configured.

Note - The current firmware version is unable to display any value for the Password Expiry Date parameter.

Local Users

Displays information about all usernames, their passwords and their authorizations.

Note - The current firmware version does not allow the User Password, Row Status and Password Valid Time parameters to be configured.

Note - The current firmware version is unable to display any value for the Password Expiry Date parameter.

Authenticated Users

Displays all the current users that have been authenticated.

EAP Method Lists

Displays information about all EAP method lists.

Note - The current firmware version does not allow the Row Status parameter to be configured.

Port-based Authentication

PAE Port Info

Displays the system level information for each port supported by the Port Access Entity.

Note - The current firmware version returns a 'noSuchName' value for the Port Number parameter.

Authenticator PAE Info

Displays configuration objects for the Authenticator PAE associated with each port.

Note - The current firmware version returns a 'noSuchName' value for the Port Number parameter.

Note - The current firmware version does not allow the Administrative Controlled Directions and Key Transmission Status parameters to be configured.

Authenticator PAE Statistics

Displays statistics objects for the Authenticator PAE associated with each port.

Note - The current firmware version returns a 'noSuchName' value for the Port Number parameter.

Authenticator PAE Diagnostics

Displays diagnostics objects for the Authenticator PAE associated with each port.

Note - The current firmware version returns a 'noSuchName' value for the Port Number parameter.

Authenticator PAE Session Statistics

Displays session statistics objects for the Authenticator PAE associated with each port.

Note - The current firmware version returns a 'noSuchName' value for the following parameters:

- Port Number
- Received Octets
- Transmitted Octets
- Received Frames
- Transmitted Frames

Note - The current firmware version is unable to display any value for the User Name parameter.

RADIUS

Basic Info

Displays basic RADIUS information.

RADIUS Server Info

Displays the IP address, UDP port number for authentication and accounting request, and current status of the RADIUS server.

Note - The current firmware version does not allow the Usage parameter to be set to 'wireless authentication'.

Authentication Client Info

Displays the number of RADIUS Access-Response packets received from unknown addresses and the identifier of the RADIUS authentication client.

Note - The current firmware version is unable to display any value for the Client ID parameter.

Authentication Server Info

Displays the list of RADIUS authentication servers with which the client shares a secret.

Accounting Client Info

Displays the number of RADIUS Access-Response packets received from unknown addresses and the identifier of the RADIUS accounting client.

Note - The current firmware version is unable to display any value for the Client ID parameter.

Accounting Server Info

Displays the list of RADIUS accounting servers with which the client shares a secret.

TACACS+

Basic Info

Displays basic TACACS+ information.

TACACS+ Server Info

Displays information about TACACS+ server.

Secure Shell

SSH Server

Displays information about the status of public key authentication and the type of regenerated host key.

Note - Configuring the Regenerate Host Key parameter will result in the error message: "The error occurred with 'Set' operation. Error: time out occurred" but a key will still be successfully generated.

SSH Client

Displays information about the user name ssh client will use and the value of the regenerated self key.

Note - The current firmware version accepts up to 60 characters for the User Name parameter.

Note - Setting the Regenerate Self Key parameter to "rsa" or "dsa" will result in the error message: "The error occurred with 'Set' operation. Error: time out occurred". Connection with the AT-8000S device will be lost and the only way to re-establish connection will be to perform a manual reset.

Note - The current firmware version does not allow the Regenerate Self Key parameter to be set to 'rsa'.

Secure Socket Layer

Basic Info

Displays basic SSL information.

Note - The current firmware version does not allow the Certificate Save parameter to be configured.

Certificate Generation

Displays information about the generated keys and self signed certificates.

Note - The current firmware version does not allow any of the parameters under this table to be configured.

Export Certificate

Displays information about the saved data from RAM and flash.

Import Certificate

Displays information about the copied external certificate of the device.

RMON Menu

From the RMON menu you can view and edit the RMON MIB.

Statistics

Displays traffic statistics in the network segment attached to each port.

History Control Table

Displays the RMON History table.

Alarm Table

Displays the RMON Alarm table.

Event Table

Displays the RMON Event table.

Event Log

Displays the RMON Event log.

Port Menu

From the Port menu, you can view and edit MIB information about the port.

Utilization

Displays the port's utilization information.

Note - The current firmware version does not allow Device Manager to display Utilization information.

Interface Info

Standard

Displays port statistics such as the number of frames received and transmitted on the port, bytes received and transmitted on the port, and port status.

Note - The current firmware version does not allow the Promiscuous Mode parameter to be configured.

Note - The current firmware version returns a "noSuchName" value for the following parameters:

- Received Error Packets
- Transmitted Error Packets
- Transmitted Buffer Length
- Received Bytes (HC)
- Received Unicast Packets (HC)
- Received Multicast Packets (HC)
- Received Broadcast Packets (HC)
- Transmitted Bytes (HC)
- Transmitted Unicast Packets (HC)
- Transmitted Multicast Packets (HC)
- Transmitted Broadcast Packets (HC)

Additional Info

Displays additional information about the port's interface info.

Error Statistics

Standard

Displays error statistics for the port.

Note - The Ethernet Chip Set parameter is not applicable to the AT-8000S series and should be ignored.

Note - The current firmware version returns a "noSuchName" value for the following parameters:

- Alignment Error Frames
- Multi Collision Frames
- SQE Test Errors
- Deferred Transmissions
- Excessive Collisions
- Internal MAC Transmit Errors
- Carrier Sense Errors
- Symbol Errors

Additional Info

Displays information about a table containing 64-bit versions of error counters.

Note - The current firmware version is unable to display any value for the Port Number and Alignment Error Frames (HC) parameters.

Note - The current firmware version returns a 'noSuchName' value for the Internal MAC Transmit Errors (HC) and Internal MAC Received Errors (HC) parameters.

Detail Info

Displays detailed port information such as duplex mode.

Note - The current firmware version does not allow the following parameters to be configured:

- Tagged Mode
- Default Priority
- Row Status
- Port Flow Control Config
- Port Speed
- Reactivate
- Combo Ethernet Config

Note - Device Manager does not handle 8-bit string parameters correctly. As a result, the Autonegotiation Capabilities Config parameter will display an unrecognizable value and will not be configurable. The Autonegotiation Capabilities Status and Remote Autonegotiation Capabilities parameters will also display unrecognizable values.

Note - The Physical Address Type parameter is not applicable to the AT-8000S series and should be ignored.

Note - The combo ports will not display the Port Context Menu on right-mouse click if logged-on in SNMPv3 mode using a user account with no read-write access to the Transceiver Type parameter.

Spanning Tree Info

STP

Standard

Displays the port's spanning tree parameters.

Additional Info

Displays a list of information maintained by every port about the Spanning Tree Protocol state for that port.

MSTP

MSTI

Displays a list of information maintained by every pair <msti, port> about the Spanning Tree Protocol state for that pair.

CIST

Displays a list of information maintained by every port of the CIST.

Enable

Enables the port.

Disable

Disables the port.

Port Lock

Basic Info

Displays basic information about port lock.

Interfaces Range

Displays information about port lock interfaces range.

MAC Control

MAC Control Sublayer

Displays information about the MAC Control sublayer on a single ethernet-like interface.

Note - The current firmware version returns a 'noSuchName' value for the Unknown Opcodes Received and Unknown Opcodes Received (HC) parameters.

MAC Control PAUSE

Displays information about the MAC Control PAUSE function on a single ethernet-like interface.

Note - Valid MIB Set values for the PAUSE Config parameter are "disabled" and "enabledXmitAndRcv". Attempting to set this parameter to any other value will result in the error message: "The error occurred with 'Set' operation. Error: bad value."

Note - The current firmware version returns a "noSuchName" value for the Received Frames (HC) and Transmit Frames (HC) parameters.

Port Trunking

Basic Info

Displays basic information about port trunking.

Note - The current firmware version does not allow any of the parameters under this table to be configured.

Balancing Criteria

Displays information about Aggregate Index.

Note - The current firmware version does not allow the Balance Layer, Used Addresses and Broadcast Type parameters to be configured.

Aggregator Info

Displays information about every Aggregator that is associated with this system.

Note - Valid MIB Set values for the Actor Administrative Key parameter are in the range [1 - 65535] inclusive. Attempting to set this parameter to a value outside of the valid range will result in the error message: "The error occurred with 'Set' operation. Error: bad value."

Aggregator Port List

Displays Link Aggregation Control information for every Aggregation Port associated with this device.

Aggregation Port Info

Displays a list of Link Aggregation Control configuration parameters for each Aggregation Port on this device.

Note - The current firmware version returns a 'noSuchName' value for the Port Number parameter.

Note - Device Manager does not handle 8-bit string parameters correctly. As a result, the Actor Administrative Status and Partner Administrative Status parameters will display unrecognizable values and will not be configurable. The Actor Operational Status and Partner Operational Status parameters will also display unrecognizable values.

Note - The current firmware version does not allow the Actor Administrative Key and Partner Administrative System ID parameters to be configured.

Storm Control

Basic Info

Displays basic information about storm control.

Storm Control Protection

Displays information about the storm control protection per port.

Note - Only the Broadcast Enable and Multicast Enable parameters can be configured.

Storm Control Group

Displays information about group id for each supported frame type defined per port.

AT-8000S Series

AT-8300GB Series

This section describes Device Manager menus and operations specific to the AT-8300GB Series.

Topics:

- Main Window
- Agent Menu
- Bridge Menu
- RMON Menu
- Port Menu
- Stacking Menu

Main Window

The screenshot displays the 'Device Manager for AT-8326GB' interface. The window title is '192.168.10.73 - Device Manager for AT-8326GB'. The menu bar includes File, View, Agent, Bridge, RMON, Port, Stacking, Tool, User, Menu, and Help. Below the menu is a toolbar with various icons for navigation and actions.

The main area contains four identical panels, each representing a different port status view for the AT-8326GB device. Each panel shows:

- 1000BASE-X** ports (SFPs) labeled 25 and 26.
- 100BASE-T/1000BASE-TX** ports (RJ-45) labeled 1 through 24.
- STACK ID** indicators labeled 1 through 6.
- RS-232 TERMINAL PORT** (ASYN0).
- DUPLEX** settings: FULL DUP (green) and HALF DUP (orange).
- STATUS** indicators: R.J-45 (green) and GBIC (orange).
- RESET** and **PMR** buttons.

The four panels show different active ports:

- Panel 1: Port 10 is active (green).
- Panel 2: Port 20 is active (red).
- Panel 3: Port 10 is active (green).
- Panel 4: Port 6 is active (red).

At the bottom of the window, there is a system information section:

- System Name:** AT-8326GB
- System Location:** ATP Lab
- System Contact:** ATP Engineering
- System Description:** AT-8326GB

A **Connect** button is located at the bottom right of the system information section.

AT-8326GB

The AT-8326GB supports up to 6 AT-8326GB stacked switches or any of the following mixed stack combinations of AT-8326GB and AT-8350GB switches:

- Two AT-8326GB switches and one AT-8350GB switch
- Two AT-8326GB switches and two AT-8350GB switches
- Three AT-8326GB switches and one AT-8350GB switch
- Four AT-8326GB switches and one AT-8350GB switch

Note - When 3 or more AT-8326GB devices are stacked together, expect the twisted pair port image of Port 26 on the last device on the stack to turn green. This is because the current firmware version returns 'on-line' for the Port Link State parameter of the port even if there is no link established.

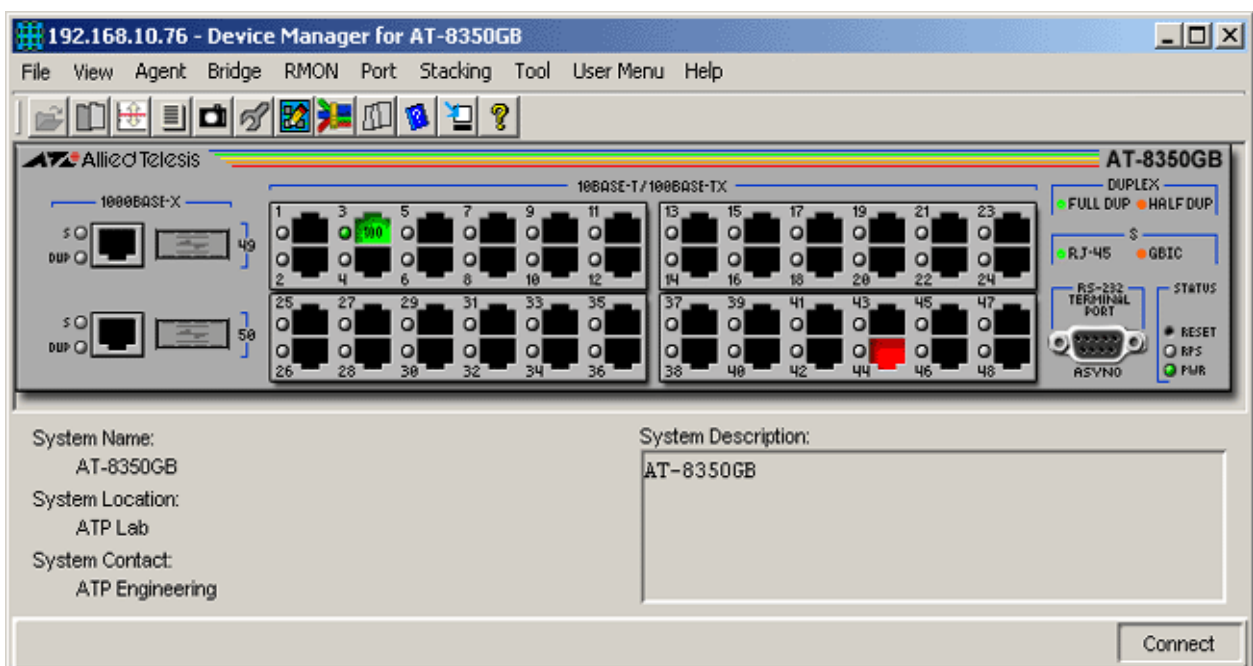

AT-8350GB

The AT-8350GB supports up to 3 stacked AT-8350GB switches.

Note - The current firmware version does not allow Device Manager to support the RPS LED.

Note - The current firmware version does not allow Device Manager to support expansion modules that may be installed on the AT-8350GB.

Device Manager LEDs for AT-8300GB Series

LED	State	Description
PWR	Green	The switch is receiving power.
STACK ID	Green	The switch's position in the switch stack.

Device Manager LEDs for AT-8300GB Series		
LED	State	Description
DUPLEX	Green	The port is operating in full-duplex mode.
	Orange	The port is operating in half-duplex mode.

Note - Status information for the gigabit ports will always be reflected on the RJ-45 gigabit port images regardless of whether the gigabit ports have been set to operate as GBIC ports or as Twisted Pair ports.

Note - When Global STP is enabled, the current firmware version sets the Port State parameter of inactive ports to 'blocking'. As a result, expect port images for inactive ports to turn yellow in Device Manager .

Note - The current firmware version does not allow Device Manager to detect the presence or absence of a GBIC module in any of the GBIC slots. As a result, the GBIC slots on the device image will remain empty regardless of whether or not GBIC modules are physically present in the slots.

Agent Menu

From the Agent menu, you can view and edit the system information for the device, or log into the CLI using Telnet.

System Info

Displays basic system information, including system name, location, contact and description.

Note - The current firmware version does not allow multiple-word values for the System Name parameter.

Note - Device Manager allows the user to enter up to 255 characters for the System Contact, System Name and System Location parameters but the current firmware version truncates them to 64 characters.

Firmware Info

Displays the version of the software running on the managed device.

Network Info

Displays network-related information such as the device IP address and the default gateway address.

Note - The current firmware version does not save changes made to the DNS Server and the Default Domain Name parameters.

DHCP Info

Displays DHCP information including the DHCP System Group and DHCP Timer Group.

Manager Address Info

Displays the IP address of the management station.

Reset

Resets the switch.

Telnet

Starts a Telnet connection to the switch.

WEB Browser

Connects to the switch's HTTP server.

Bridge Menu

From the Bridge menu, you can view and edit bridge information such as the forwarding database and the spanning tree status.

Forwarding Database

Standard View

Displays the Forwarding Database table as returned by the device.

Enhanced View

Displays the Forwarding Database table on a per port basis. User can select a port or group of ports to view its corresponding Forwarding Database entries.

Discard/Aging Time Info

Displays information about the number of address entries that were learned but discarded because of lack of memory or the entry's aging timer has expired.

Note - The current firmware version accepts values in the range [10-1000000] inclusive for the Aging Time parameter.

Spanning Tree Info

Displays spanning tree parameters such as priority and cost.

Statistics

Displays statistics about frames received/transmitted on the switch's ports.

RMON Menu

From the RMON menu you can view and edit the RMON MIB.

Statistics

Displays traffic statistics in the network segment attached to each port.

History Control Table

Displays the RMON History table.

Alarm Table

Displays the RMON Alarm table.

Event Table

Displays the RMON Event table.

Event Log

Displays the RMON Event log.

Port Menu

From the Port menu, you can view and edit MIB information about the port.

Utilization

Displays the port's utilization information.

Interface Info

Displays port statistics such as the number of frames received and transmitted on the port, bytes received and transmitted on the port, and port status.

Note - Valid MIB Set values for the Administration Status parameter are 'up' and 'down'. Attempting to set this parameter to any other value will result in the error message: "The error occurred with 'Set' operation. Error: gen Error."

Detail Info

Displays detailed port information such as duplex mode.

Note - The Port Transmit Pacing Configuration parameter is not applicable to the AT-8300GB Series.

Note - The Port VLAN Tag Priority parameter has a fixed value of 'use vlan priority' and cannot be modified.

Note - The current firmware version does not allow the Port Bridge ID parameter to be configured. Attempting to configure this parameter will result in the error message: "The error occurred with 'Set' operation. Error: bad value".

Note - When a port's Port Speed and Mode parameter is set to 'auto sense', the current firmware version does not update its Port Duplex Status parameter with the negotiated mode. As a result, the port's Port Duplex Status parameter will always display 'auto sense' and its corresponding Duplex LED will always be green regardless of the actual connection mode.

Note - The Port Name parameter is not applicable to the AT-8300GB Series.

Note - Valid MIB Set values for the Port State parameter are 'enabled' and 'disabled'. Attempting to set this parameter to any other value will result in the error message: "The error occurred with 'Set' operation. Error: bad value."

Spanning Tree Info

Displays the port's spanning tree parameters.

Enable

Enables the port.

Disable

Disables the port.

QoS

Displays QoS parameters and allows enabling of QoS status and setting priority queue.

Port Mirroring

Displays port mirroring parameters and allows configuration of port mirroring state, source and destination.

IGMP Snooping

Displays the current state of IGMP Snooping and allows reconfiguration.

Stacking Menu

From the Stacking menu, you can view basic switch information as well as stacking information.

Stacking Info

Displays information such as Product Type, Port Count, and Uplink Types for all switches in the stack.

Note - The Uplink Port A MDA Type and Uplink Port B MDA Type parameters return incorrect values.

Note - The Security Action parameter returns '???(0)' when the Security Configuration parameter is set to 'disabled'.

AT-8400

This section describes Device Manager menus and operations specific to the AT-8400 switch.

Topics:

- Main Window
- Agent Menu
- Bridge Menu
- RMON Menu
- Port Menu
- Stacking Menu

Main Window

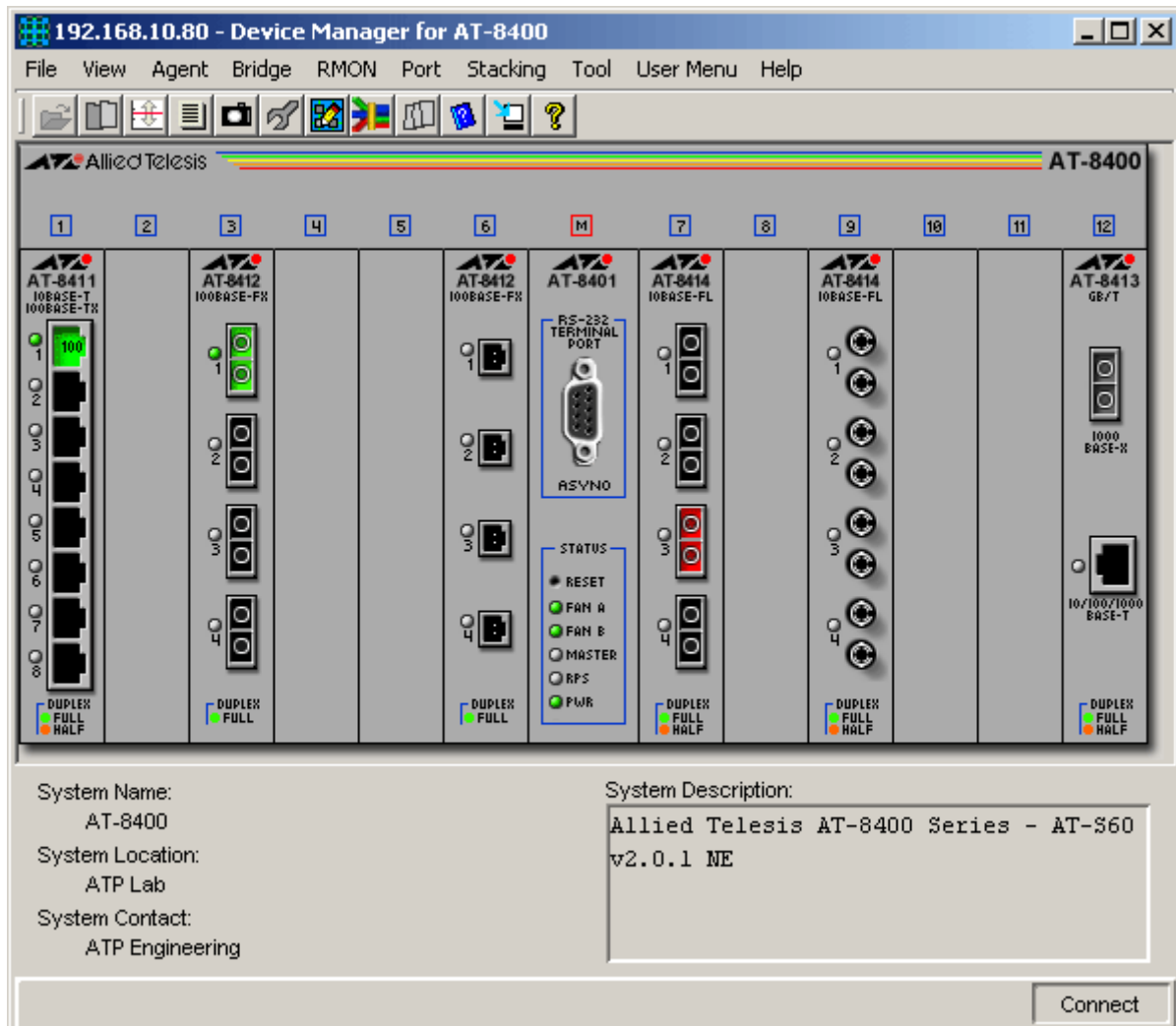

AT-8400

Device Manager LEDs for AT-8401 Management Module		
LED	State	Description
FAN A	Green	FAN TRAY A is installed and is operating correctly.
	Gray	FAN TRAY A is not installed.
FAN B	Green	FAN TRAY B is installed and is operating correctly.
	Gray	FAN TRAY B is not installed.
MASTER	Green	The switch is the master of an enhanced stack.
	Gray	The switch is either a slave switch of an enhanced stack or the switch is not a member of an enhanced stack.

Device Manager LEDs for AT-8401 Management Module		
LED	State	Description
RPS	Green	The switch is receiving power from the redundant power supply (PWR B).
	Gray	The switch is receiving power from the main power supply (PWR A).
PWR	Green	The switch is receiving power from the main power supply (PWR A).
	Gray (Only if RPS is installed)	The main power supply is not functioning.

Note - Please refer to AT-8400 Line Cards for the operations and behavior of the line cards installed on the chassis.

Note - The FAN A and FAN B LEDs are always green regardless of whether or not fan trays are actually installed.

Note - The PWR LED is always green and the RPS LED is always gray regardless of whether the switch is receiving power from the main power supply or the redundant power supply.

Note - Some parameters, when configured, may at times cause a temporary loss of connection. When this happens, the following error message appears: "The error occurred with 'Set' operation. Error: time out occurred.". This will not affect the application in any way.

Agent Menu

From the Agent menu, you can view and edit the system information for the device, or log into the CLI using Telnet.

System Info

Displays basic system information, including system name, location, contact and description.

Network Info

Displays network-related information such as the addresses of the default gateway and the agents.

Note - The current firmware version does not allow the DNS Server and Default Domain Name parameters to be configured. Attempting to configure these parameters will result in the error message: "The error occurred with 'Set' operation. Error: gen Error.".

Chassis Info

Displays chassis information including the firmware information.

Note -The current firmware version does not allow the Power A Status and Power B Status parameters to be configured. Attempting to configure these parameters will result in the error message: "The error occurred with 'Set' operation. Error: gen Error."

Line Card Info

Displays information for each line card including line card type and line card temperature.

MAC Address Table

Displays a list of static MAC address configured on the switch.

Note - Valid MIB Set values for the MAC Address Entry Status parameter are 'active', 'not in service' and 'destroy'. Attempting to set this parameter to any other value will result in error message: "The error occurred with 'Set' operation. Error: bad value".

Reset

Resets the switch.

Telnet

Starts a Telnet connection to the switch.

WEB Browser

Connects to the switch's HTTP server.

Bridge Menu

From the Bridge menu, you can view and edit bridge information such as the forwarding database and the spanning tree status.

Forwarding Database

Displays the Forwarding Database table.

Note - It may take some time to retrieve Forwarding Database information. As a result, some Forwarding Database parameters may not show any value. To avoid this, click on File > Property > Polling options and set the Polling Interval parameter to 25 seconds or longer.

Discard/Aging Time Info

Displays information about the number of address entries that were learned but discarded because either there was a lack of memory or the entry's aging timer expired.

Spanning Tree Info

Displays spanning tree parameters such as spanning tree status and spanning tree version.

Note - When setting the Spanning Tree Status parameter to 'enabled', connection to the AT-8400 is temporarily lost. As a result, the following error message appears: "The error occurred with 'Set' operation. Error: time out occurred."

Note - Setting the value of the Spanning Tree Version parameter to 'stp' will result in a permanent loss of connection. To re-establish connection, restart the device.

Statistics

Displays statistics about frames received/transmitted on the switch's ports.

Note - Ports are numbered continuously from top to bottom, across all installed line cards, starting from the leftmost line card all the way through the rightmost line card.

RMON Menu

From the RMON menu you can view and edit the RMON MIB.

Statistics

Displays traffic statistics in the network segment.

History Control Table

Displays the RMON History table.

Note - The current firmware version does not support the "historyControlTable" MIB object of RFC1757. As a result, Device Manager displays the error message "Failed to get MIB data." when the History Control Table option is selected from the RMON menu.

Alarm Table

Displays the RMON Alarm table.

Event Table

Displays the RMON Event table.

Event Log

Displays the RMON Event log.

Port Menu

From the Port menu, you can view and edit MIB information about the port.

Note - Ports are numbered continuously from top to bottom, across all installed line cards, starting from the leftmost line card all the way through the rightmost line card. This applies to the following submenu options:

- Utilization
- Interface Info -> Standard
- Error Statistics -> Standard
- Spanning Tree Info

Utilization

Displays the port's utilization information.

Interface Info

Displays port statistics such as the number of frames received and transmitted on the port, bytes received and transmitted on the port, and port status.

Note - Valid MIB Set values for the Administration Status parameter are 'up' and 'down'. Attempting to set this parameter to any other value will result in the error message: "The error occurred with 'Set' operation. Error: bad value."

Error Statistics

Displays error statistics such as alignment error frames and carrier sense errors.

Detail Info

Displays detailed port information such as duplex mode.

Note - The current firmware version does not allow the Port Name parameter to be set to NULL. Attempting to set this parameter to NULL will result in the error message: "The error occurred with 'Set' operation. Error: bad value."

Spanning Tree Info

Displays the port's spanning tree parameters.

Note - The current firmware version does not allow the Port parameter to be configured. Attempting to configure this parameter will result in the error message: "The error occurred with 'Set' operation. Error: readOnly".

Port Security

Displays the port security attributes for each physical port present in the switch.

Enable

Enables the port.

Disable

Disables the port.

Port Mirroring

Displays port mirroring parameters and allows configuration of port mirroring state and port's source list.

Note - Valid MIB Set values for the Port Mirroring Configuration Entry Status parameter are 'active', 'not in service' and 'destroy'. Attempting to set this parameter to any other value will result in the error message: "The error occurred with 'Set' operation. Error: bad value."

Stacking Menu

From the Stacking menu, you can view basic switch information as well as stacking information.

Stacking Info

Displays information such as Stack Switch ID, Stack Switch MAC Address, Stack Switch Name, Stack Switch Mode, Stack Switch Software Version and Stack Switch Model for all switches in the stack.

AT-8400

AT-8400 Line Cards

This section describes the AT-8400 Line Cards supported by Device Manager. If line cards are installed on the AT-8400 chassis at the time Device Manager is called, they will be displayed in their corresponding slots on the chassis image.



- AT-8411
- AT-8412
- AT-8413
- AT-8414

AT-8411

AT-8411		
		
LED	State	Description
DUPLEX	Green	The port is operating in full-duplex.
	Orange	The port is operating in half-duplex.

Note - When a port on the AT-8411 line card is configured to auto-negotiate and is connected to a 10/100 Mbps full-duplex port on another device, the current firmware version returns the value 'half-duplex' for the Port Duplex Status parameter. As a result, the Duplex LED turns orange instead of green.

AT-8412

AT-8412/MT		AT-8412/SC	
			
LED	State	Description	
DUPLEX	Green	The port is operating in full-duplex.	

Note - The current firmware version does not allow the Port Flow Control parameter of ports on the AT-8412/MT and AT-8412/SC line cards to be set to 'auto'. Attempting to set this parameter to 'auto' will result in the error message: "The error occurred with 'Set' operation. Error: gen Error".

AT-8413



AT-8413GB/T		
		
LED	State	Description
DUPLEX	Green	The port is operating in full-duplex.
	Orange	The port is operating in half-duplex.

Note - A GBIC image is always visible on the GBIC slot of the AT-8413GB/T line card image even if there is no GBIC physically present in the slot.

Note - Status information for the AT-8413GB/T ports will always be reflected on the RJ-45 port image regardless of whether the port that is in actual use is the GBIC port or the twisted pair port.

Note - When the 10/100/1000Base-T port of the AT-8413GB/T line card is configured to auto-negotiate and is connected to a 10/100Mbps full-duplex port on another device, the current firmware version returns the value 'half-duplex' for the Port Duplex Status parameter. As a result, the Duplex LED turns orange instead of green.

AT-8414

AT-8414/SC		AT-8414/ST	
			
LED	State	Description	
DUPLEX	Green	The port is operating in full-duplex.	
	Orange	The port is operating in half-duplex.	

Note - The Port Negotiation parameter of ports on the AT-8414/SC and AT-8414/ST line cards has a fixed value of '10Mbps full-duplex' and cannot be modified.

AT-9000/24

This section describes Device Manager menus and operations specific to the AT-9000/24 switch.

Topics:

- Main Window
- Agent Menu
- Bridge Menu
- RMON Menu
- Port Menu

Main Window

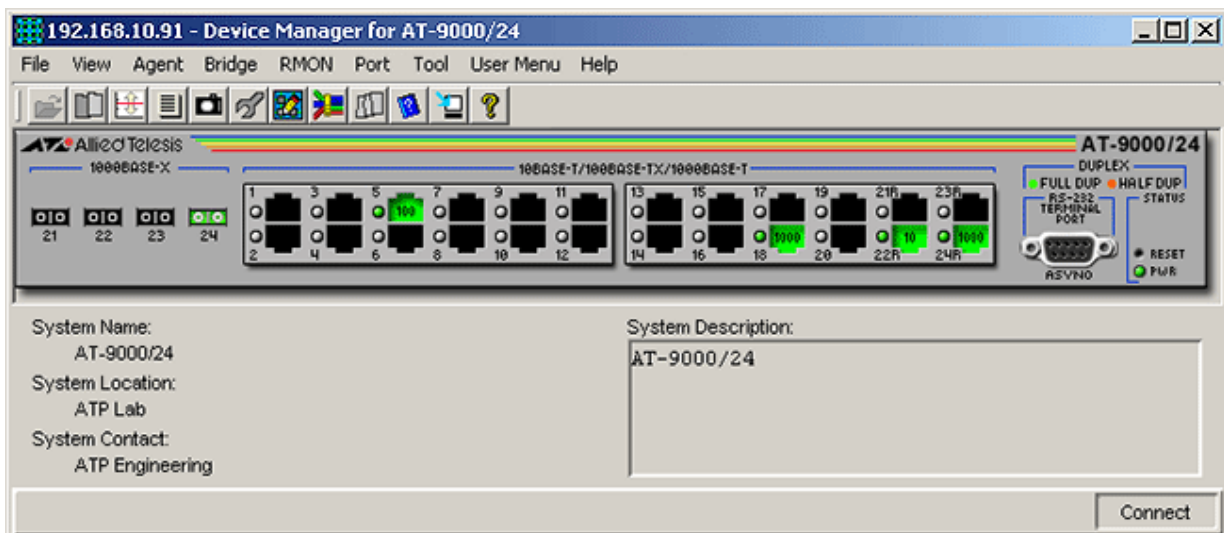

AT-9000/24

Device Manager LEDs for AT-9000/24		
LED	State	Description
PWR	Green	The switch is receiving power.
DUPLEX	Green	The port is operating at full-duplex mode.
	Orange	The port is operating at half-duplex mode.

Note - Disabled ports will not turn red.

Note - The current firmware version does not allow Device Manager to detect the presence or absence of an SFP module in any of the SFP slots. As a result, the SFP slots on the device image will always show SFP images regardless of whether or not SFP modules are physically present in the slots.

Note - Status information for ports 21 to 24 will always be reflected on both the RJ-45 port images and the SFP port images regardless of whether it is the RJ-45 or the SFP ports that are actually in operation. However, if Device Manager detects that the established link speed is less than 1 Gbps, only the RJ-45 port images will turn green.

Note - When Global RSTP is enabled, the current firmware version sets the Port State parameter of inactive ports to 'blocking'. As a result, expect port images for inactive ports to turn yellow in Device Manager.

Agent Menu

From the Agent menu, you can view and edit the system information for the device, or log into the CLI using Telnet.

System Info

Displays basic system information, including system name, location, contact and description.

Note - The current firmware version accepts up to 64 characters for the System Contact, System Name and System Location parameters.

Firmware Info

Displays firmware version.

Network Info

Displays network-related information such as the addresses of the default gateway and the agents.

Manager Address Info

Displays the IP address of the management station.

Note - The current firmware version does not return the correct values for the Trap Destination IP Address parameters if these are retrieved in bulk. As a result, all Trap Destination IP Address parameters will display a value of '0.0.0.0' upon initial display of the Manager Address Info table. To retrieve the correct values, a Get MIB Value must be performed on each Trap Destination IP Address parameter, one at a time. The same is true if their values need to be modified. A Set MIB Value would have to be performed on each instance of the parameter, one at a time.

DHCP Info

Displays DHCP information including the DHCP System Group and DHCP Timer Group.

Reset

Resets the switch.

Telnet

Starts a Telnet connection to the switch.

WEB Browser

Connects to the switch's HTTP server.

Bridge Menu

From the Bridge menu, you can view and edit bridge information such as the spanning tree status.

Bridge Info

General

Displays basic bridge information such as the LAN ID, bridge address, number of ports and the bridge type.

Port

Displays basic bridge information on a per port basis such as the LAN ID, port number, circuit, delay exceeded discards and MTU exceeded discards.

Note - The current firmware version returns a NULL value for the Circuit parameter.

Spanning Tree Info

Displays spanning tree parameters such as priority and cost.

Note - Values entered for the Root Maximum Aging Time, Root Hello Time and Root Forward Delay Time parameters must be multiples of 100. Values that are not multiples of 100 will be automatically rounded down to the nearest hundreds.

Statistics

Displays statistics about frames received/transmitted on the switch's ports.

RMON Menu

From the RMON menu you can view and edit the RMON MIB.

Statistics

Standard

Displays traffic statistics in the network segment attached to each port.

Note - The current firmware version does not support RFC1757. As a result, Device Manager will display the error message "Failed to get MIB data."

Additional Info

Displays additional traffic statistics in the network segment such as frames received/sent, collisions, broadcast frames and multicast frames.

Error

Displays error statistics in the network segment such as CRC errors, alignment errors, bad frames received late collisions and total transmit errors.

Note - There may be times when Device Manager will not be able to successfully retrieve error statistical information. When this happens, all parameters in this table will display the value "retry over occurred". To prevent this from happening, do the following:

- Go to File -> Property.
- Click on the Settings button in the Polling Options area.
- Increase the value of the Timeout parameter in the Retry area.

History Control Table

Displays the RMON History table.

Note - The current firmware version does not support RFC1757. As a result, Device Manager will display the error message "Failed to get MIB data."

Alarm Table

Displays the RMON Alarm table.

Event Table

Displays the RMON Event table.

Event Log

Displays the RMON Event log.

Port Menu

From the Port menu, you can view and edit MIB information about the port.

Utilization

Displays the port's utilization information.

Interface Info

Standard

Displays port statistics such as the number of packets received and transmitted on the port, bytes received and transmitted on the port and port status.

Note - The current firmware version does not support the Specific Media MIB parameter.

Additional Info

Displays port statistics such as the number of frames received and transmitted on the port, bytes received and transmitted on the port and port status.

Error Statistics

Displays error statistics.

Detail Info

Displays detailed port information such as duplex mode.

Note - The Port State parameter always returns the value 'enabled' even if the physical port is actually disabled.

Note - When an auto-negotiated link is established on a redundant port (RJ-45), its Port Speed parameter, as well as its port image, may not always reflect the correct negotiated speed if there is an established link on any of the other three SFP ports.

Spanning Tree Info

Displays the port's spanning tree parameters.

Enable

Enables the port.

Disable

Disables the port.

Port Mirroring

Displays port mirroring parameters and allows configuration of port mirroring state, source and destination.

IGMP Snooping

Displays the current state of IGMP Snooping and allows reconfiguration.

AT-9006 Family

This section describes Device Manager menus and operations specific to the AT-9006SX/SC and AT-9006T switches.

Topics:

- Main Window
- Agent Menu
- Bridge Menu
- RMON Menu
- VLAN Menu
- Port Menu

Main Window

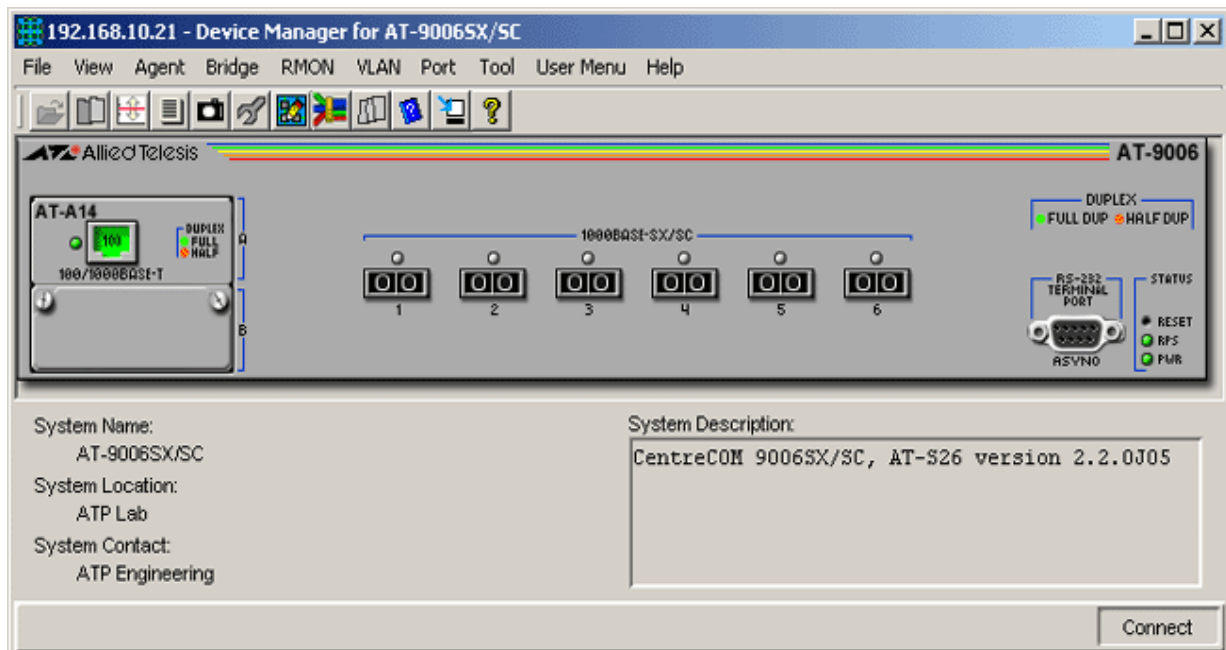

AT-9006SX/SC

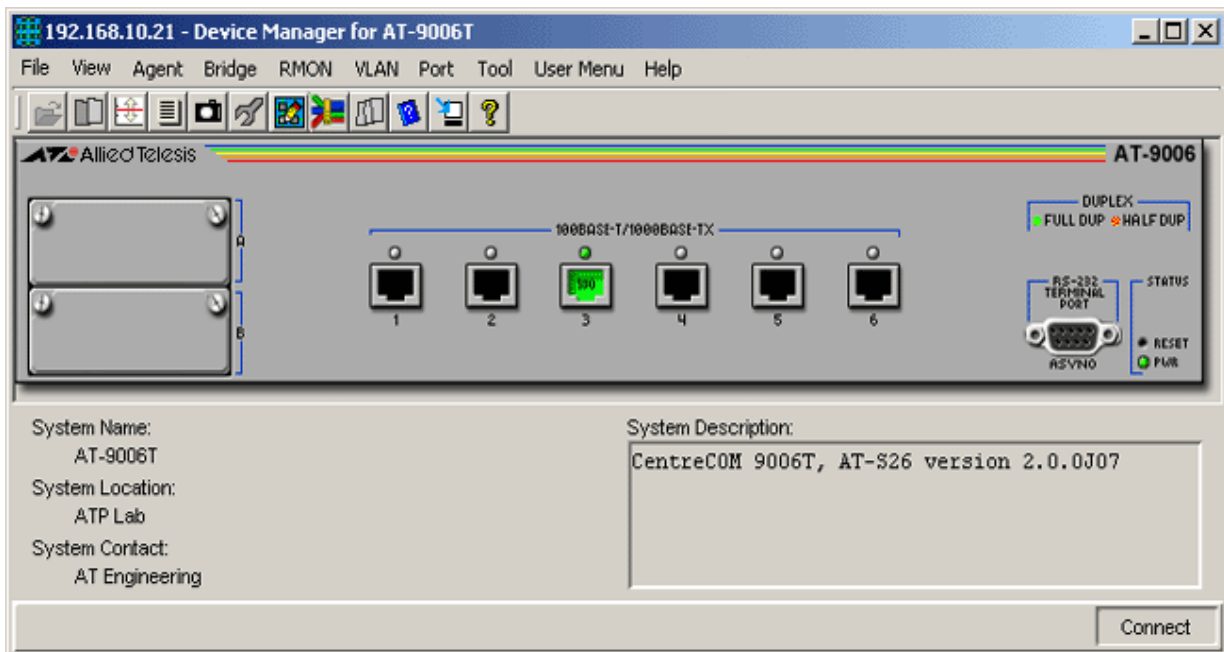

AT-9006T

Device Manager LEDs for AT-9006 Family		
LED	State	Description
PWR	Green	The switch is receiving power.
RPS	Green	An optional redundant power supply is connected to the switch.
	Gray	There is no redundant power supply connected to the switch.
DUPLEX	Green	The port is operating in full-duplex mode.
	Orange	The port is operating in half-duplex mode.

Note - Ports on the expansion modules are numbered starting from 7. Slot A's leftmost port has the smallest number and Slot B's rightmost port has the largest number.

Agent Menu

From the Agent menu, you can view and edit the system information for the device, or log into the CLI using telnet.

System Info

Displays basic system information, including system name, location, contact and description.

Firmware Info

Displays firmware version.

Network Info

Displays network-related information such as agent's and default gateway address.

Manager Address Info

Displays management station's IP address.

Reset

Reset the switch.

Telnet

Connect to the switch's telnet service.

Bridge Menu

From the Bridge menu, you can view and edit information such as forwarding database and spanning tree status.

Forwarding Database

Displays forwarding database table.

Discard/Aging Time Info

Displays information about number of address entry that was learned but discarded because of the reason such as memory shortage and entry's aging time.

Spanning Tree Info

Displays spanning tree parameters such as priority and cost.

Statistics

Displays statistics of frames received/transmitted on the switch port.

RMON Menu

From the RMON menu, you can view and edit RMON MIB.

Note - Since RMON data may be large, it may take some time for information to appear.

Statistics

Displays traffic statistics in the network segment attached to each port.

History Control Table

Displays RMON History table.

Alarm Table

Displays RMON Alarm table.

Event Table

Displays RMON Event table.

Event Log

Displays RMON Event log.

VLAN Menu

From the VLAN menu, you can view the list of VLAN and member ports.

Note - You cannot modify VLAN configuration on the AT-9006 Family using the VLAN menu.

Name List

Displays configured VLAN names.

Port Info

Displays VLAN to which the port belongs.

Port Menu

From the Port menu, you can view and edit MIB information about the port.

Utilization

Displays port's utilization information.

Interface Info

Displays port statistics such as number of frames received/transmitted on the port, bytes received/transmitted on the port and port status.

Error Statistics

Displays error statistics.

Detail Info

Displays detailed port information such as duplex mode, speed, spanning tree protocol status and switching mode.

Spanning Tree Info

Displays port's spanning tree parameters.

Enable

Enables the port.

Disable

Disables the port.

AT-9410GB

This section describes Device Manager menus and operations specific to the AT-9410GB switch.

Topics:

- Main Window
- Agent Menu
- Bridge Menu
- RMON Menu
- Port Menu

Main Window

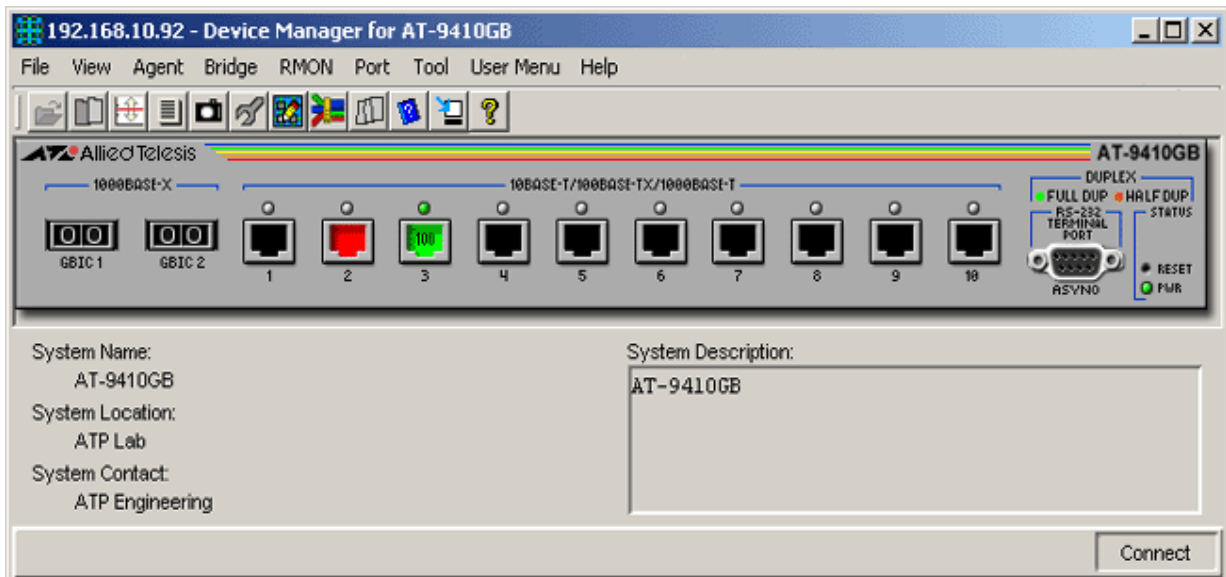

AT-9410GB

Device Manager LEDs for AT-9410GB		
LED	State	Description
PWR	Green	The switch is receiving power.
DUPLEX	Green	The port is operating at full-duplex mode.
	Orange	The port is operating at half-duplex mode.

Note - When Global STP is enabled, the current firmware version sets the Port State parameter of inactive ports to 'blocking'. As a result, expect port images for inactive ports to turn yellow in Device Manager.

Note - When a port on the AT-9410GB is set to 'auto sense' and is connected to a half-duplex port on another device, its corresponding Duplex LED on the device image turns green instead of orange.

Note - A GBIC image is always visible on each of the GBIC slots of the device image even if there are no GBICs physically inserted.

Agent Menu

From the Agent menu, you can view and edit the system information for the device, or log into the CLI using Telnet.

System Info

Displays basic system information, including system name, location, contact and description.

Note - The current firmware version does not allow the user to enter multiple-word values for the System Name parameter.

Note - Device Manager allows the user to enter up to 255 characters for the System Contact, System Name, and System Location parameters but truncates them to 64 characters.

Firmware Info

Displays firmware version.

Network Info

Displays network-related information such as the addresses of the default gateway and the agents.

Note - The current firmware version does not save changes made to the DNS Server and the Default Domain Name parameters.

Manager Address Info

Displays the IP address of the management station.

Device Info

Displays general information about the switch.

Note - The Security Action parameter returns '???(0)' when the Security Configuration parameter is set to 'disabled'.

DHCP Info

Displays DHCP information including the DHCP System Group and DHCP Timer Group.

Reset

Resets the switch.

Telnet

Starts a Telnet connection to the switch.

WEB Browser

Connects to the switch's HTTP server.

Bridge Menu

From the Bridge menu, you can view and edit bridge information such as the forwarding database and the spanning tree status.

Bridge Info

Displays basic bridge information such as the LAN ID, bridge address, number of ports and the bridge type.

Forwarding Database

Displays the Forwarding Database table.

Discard/Aging Time Info

Displays information about the number of address entries that were learned but discarded because either there was a lack of memory or the entry's aging timer expired.

Note - The current firmware version accepts values in the range [10-1000000] inclusive for the Aging Time parameter.

Spanning Tree Info

Displays spanning tree parameters such as priority and cost.

Statistics

Displays statistics about frames received/transmitted on the switch's ports.

RMON Menu

From the RMON menu you can view and edit the RMON MIB.

Statistics

Displays traffic statistics in the network segment attached to each port.

History Control Table

Displays the RMON History table.

Alarm Table

Displays the RMON Alarm table.

Event Table

Displays the RMON Event table.

Event Log

Displays the RMON Event log.

Port Menu

From the Port menu, you can view and edit MIB information about the port.

Utilization

Displays the port's utilization information.

Interface Info

Displays port statistics such as the number of frames received and transmitted on the port, bytes received and transmitted on the port, and port status.

Note - Valid MIB Set values for the Administration Status parameter are 'up' and 'down'. Attempting to set this parameter to any other value will result in the error message: "The error occurred with 'Set' operation. Error: gen Error."

Error Statistics

Displays error statistics.

Detail Info

Displays detailed port information such as duplex mode.

Note - The Port Name parameter is not applicable to the AT-9410GB.

Note - The current firmware version does not allow the Port VLAN Tag Priority parameter to be configured. Attempting to configure this parameter will result in the error message: "The error occurred with 'Set' operation. Error: bad value."

Note - The Port Transmit Pacing Configuration parameter is not applicable to the AT-9410GB.

Note - Device Manager allows the user to disable an active port. However, the disabled port's Port Link State parameter retains the value 'on-line'.

Note - When connection is established between a twisted pair port that is configured to auto-negotiate and a port on another device that is configured to operate at 10/100Mbps full/half duplex, expect the link to drop when the twisted pair port's speed and mode is changed to match the speed and mode of the port on the other device.

Note - Valid MIB Set values for the Port State parameter are 'enabled' and 'disabled'. Attempting to set this parameter to any other value will result in the error message: "The error occurred with 'Set' operation. Error: bad value."

Spanning Tree Info

Displays the port's spanning tree parameters.

Enable

Enables the port.

Disable

Disables the port.

QoS

Displays QoS parameters and allows enabling of QoS status and setting priority queue.

Port Mirroring

Displays port mirroring parameters and allows configuration of port mirroring state, source and destination.

IGMP Snooping

Displays the current state of IGMP Snooping and allows reconfiguration.

Routers

AT-AR400S Series

This section describes Device Manager menus and operations specific to the AT-AR400S Series.

Topics:

- Main Window
- Agent Menu
- Routing Menu
- Bridge Menu
- ATM Menu (not applicable to the AT-AR450S)
- ADSL Menu (AT-AR440S and AT-AR441S only)
- SHDSL Menu (AT-AR442S only)
- Port Menu

Main Window

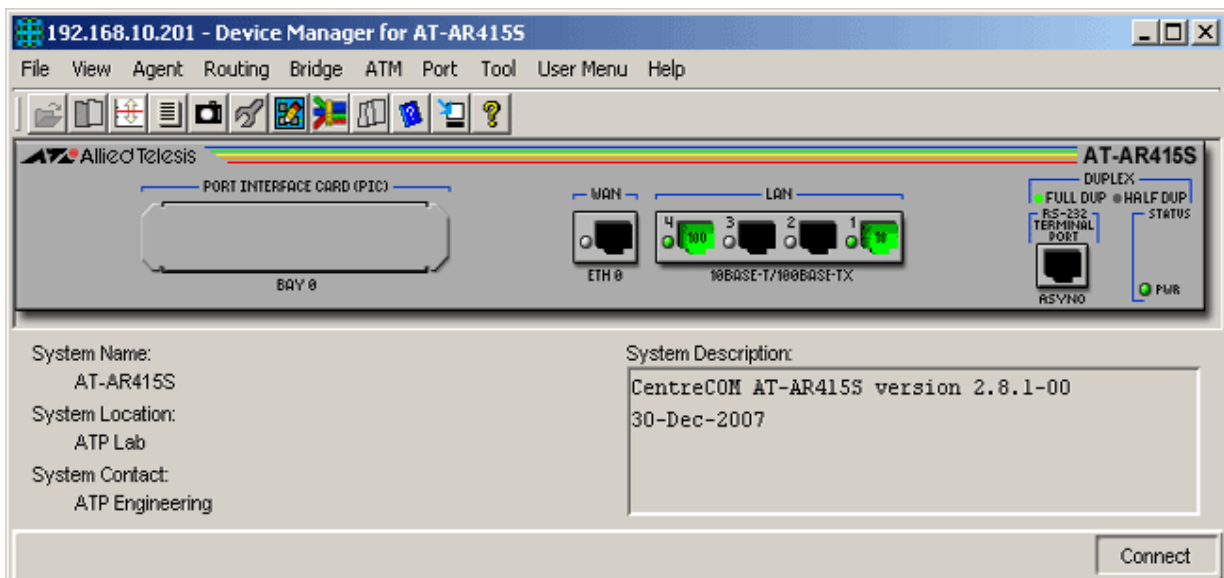

AT-AR415S

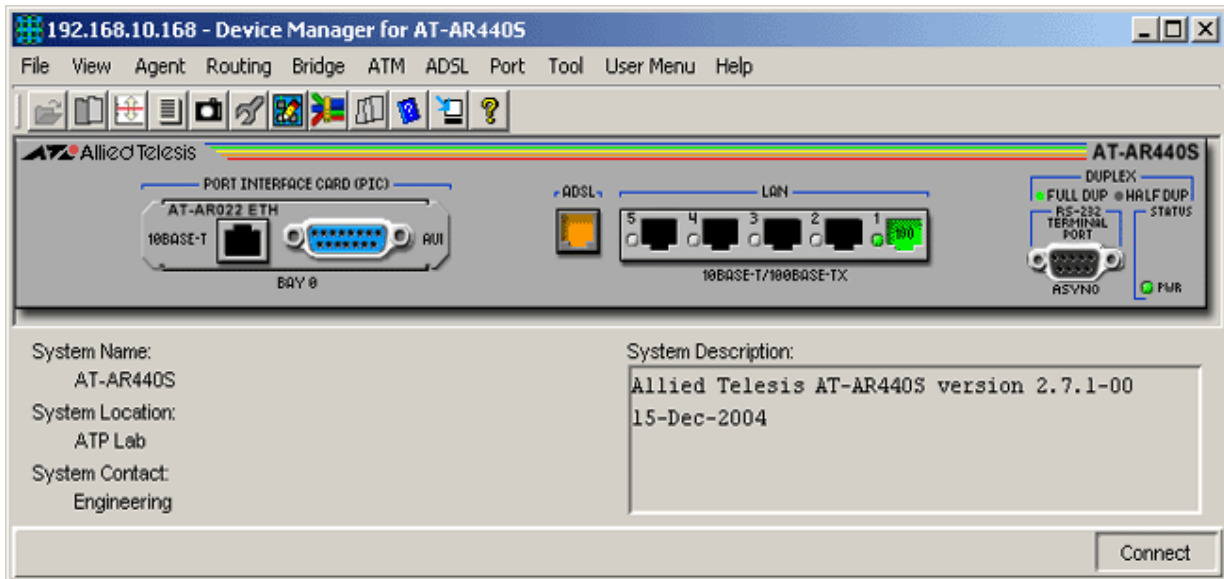

AT-AR440S

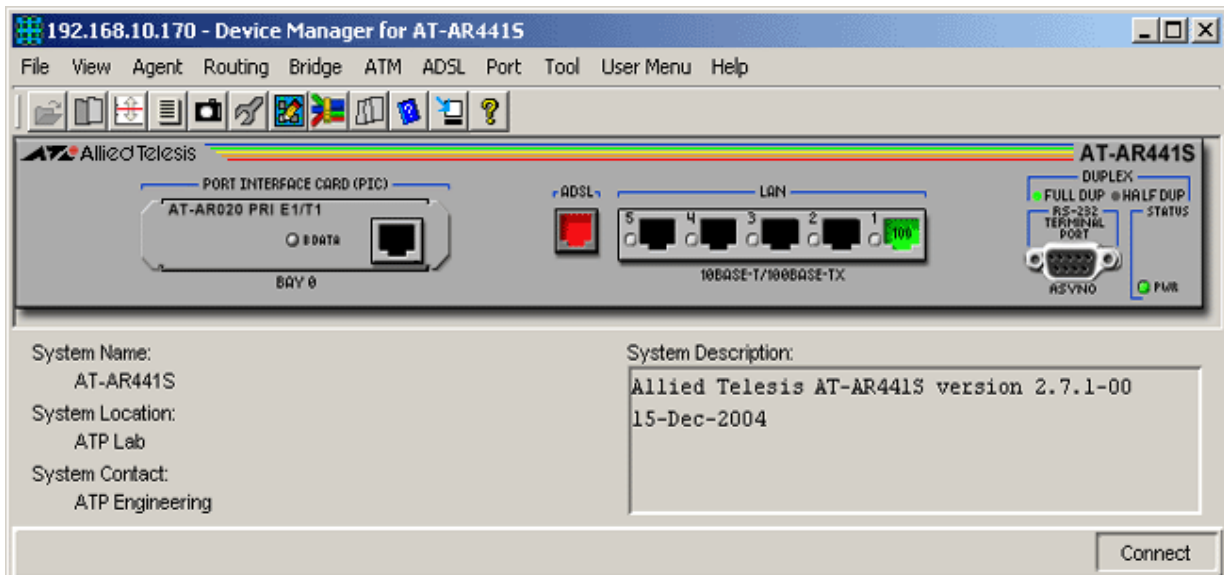

AT-AR441S

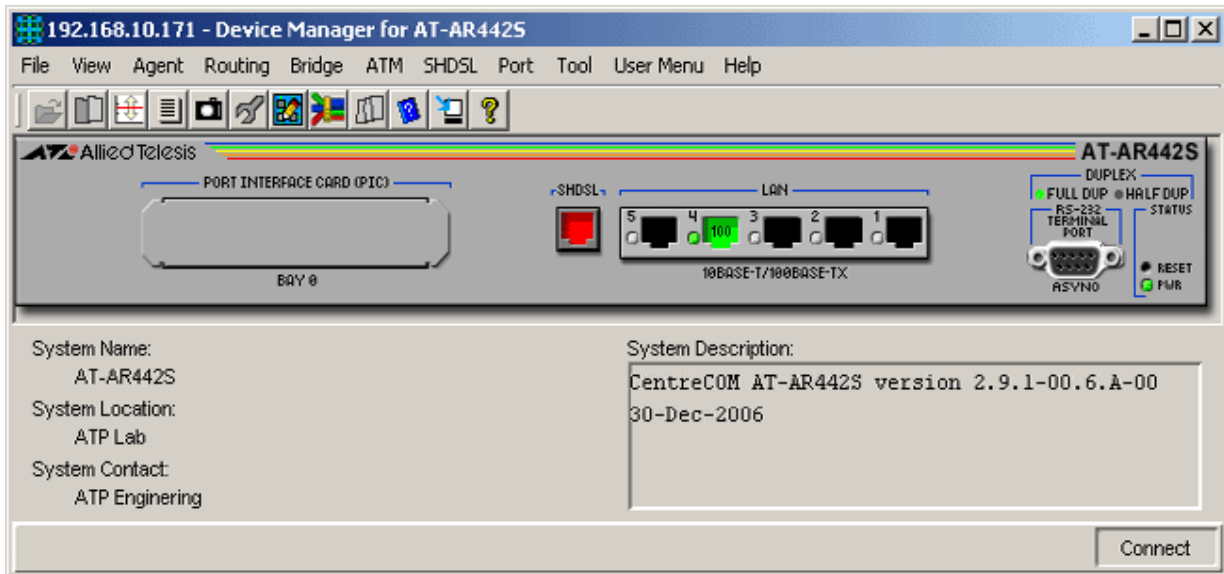

AT-AR442S

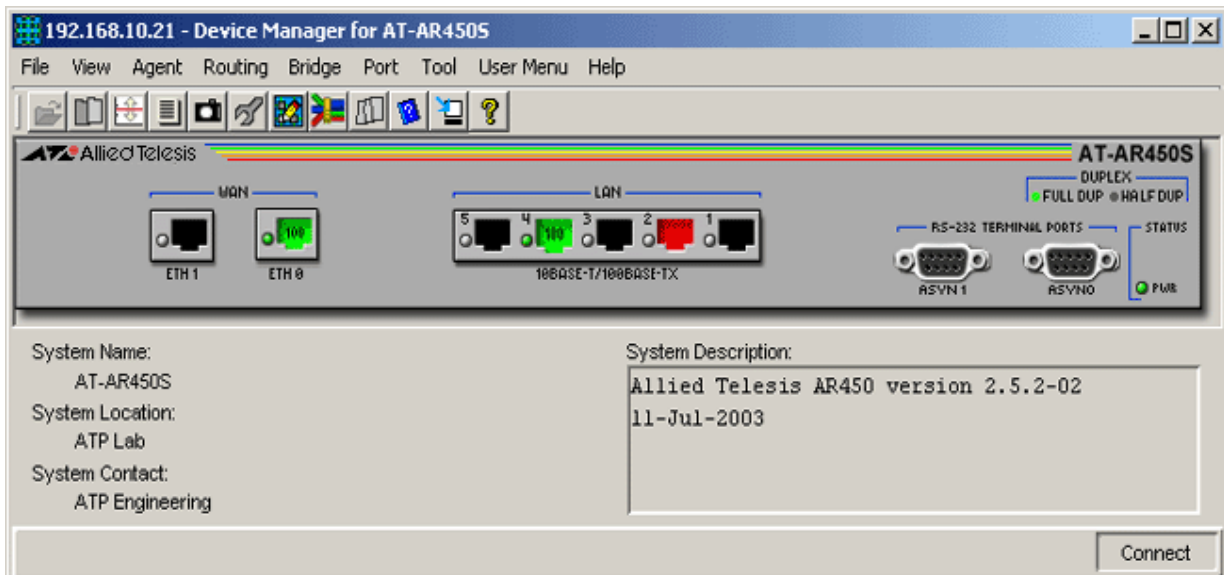

AT-AR450S

Device Manager LEDs for AT-AR400S Series

LED	State	Description
PWR	Green	The router is receiving power.
DUPLEX	Green	The port is operating at full-duplex.
	Gray	The port is either inactive or is operating at half-duplex.
ADSL	Green	The interface is enabled and the link is up.
	Orange	The interface is enabled and is handshaking. The interface is enabled and is training to negotiate the link.

Device Manager LEDs for AT-AR400S Series		
	Black	The interface is enabled and the link is down.
	Red	The interface is disabled.

Note - Please refer to Port Interface Cards (PICs) for the operations and behavior of the Port Interface Cards installed in these devices.

Agent Menu

From the Agent menu, you can view and edit the system information for the router, or log into the CLI using Telnet.

System Info

Displays basic system information, including system name, location, contact and description.

File List

Displays a list of the files in the router's flash and NVS file systems.

Config File Name

Displays the file name of the start-up configuration file.

Telnet

Starts a Telnet connection to the router.

WEB Browser

Opens your web browser and connects to the switch's HTTP server.

Note - The web browser can only contact the device if the device has a valid resource file loaded and set, and the HTTP server and GUI on the device are enabled.

Routing Menu

From the Routing menu, you can view and edit information about the router's IP routing functions.

ARP Table

Displays the mapping of IP addresses to MAC addresses (the ARP cache) on the router.

Address Table

Displays the list of IP interfaces and their IP addresses on the router.

Route Table

Displays the IP routing table on the router.

IP Statistics

Displays statistics about IP routing, including the number of IP datagrams received.

ICMP Statistics

Displays ICMP statistics.

Bridge Menu

From the Bridge menu, you can view and edit bridge information such as the forwarding database and spanning tree status. The Bridge submenus are greyed out if bridges not configured.

Discard/Aging Time Info

Displays information about the number of address entries that were learned but discarded because either there was a lack of memory or the entry's aging timer expired.

Spanning Tree Info

Displays spanning tree parameters such as priority and cost.

ATM Menu

From the ATM menu you can view and edit ATM information. The ATM instance submenus are greyed out if no ATM instances are configured. The ATM channel submenus are greyed out if no ATM channels are configured.

Instance Configuration

Displays ATM Instance configuration information.

Note - The current firmware version does not allow the following parameters to be configured:

- Max VPC
- Max VCC
- Max Active VPI Bits
- Max Active VCI Bits
- ILMI VPI
- ILMI VCI
- Neighbor IP Address
- Neighbor Name

Attempting to configure these parameters will result in the error message: "The error occurred with 'Set' operation. Error: noSuchName."

Channel Configuration

Displays ATM Channel configuration information.

Note - The current firmware version does not allow the following parameters to be configured:

- Receive Traffic Descriptor Index
- Transmit Traffic Descriptor Index

Attempting to configure these parameters will result in the error message: "The error occurred with 'Set' operation. Error: noSuchName."

Channel Error Statistics

Displays information about errors related to ATM channels.

ADSL Menu

From the ADSL menu, you can view ADSL interface information.

Line Info

Displays information about the ADSL line.

Physical Info

Displays information about the ADSL physical layer parameters.

Performance Statistics

Displays ADSL event counters.

Interval Statistics

Displays ADSL interval counters.

SHDSL Menu

From the SHDSL menu, you can view SHDSL interface information.

Status

Displays overall status information of the HDSL2/SHDSL spans.

Performance

Displays status and performance information for segment endpoints in HDSL2/SHDSL Lines.

Line Configuration

Displays span configuration profiles for SHDSL lines.

Alarm Configuration

Displays alarm configuration profiles for HDSL2/SHDSL segment endpoints.

Port Menu

From the Port menu, you can view and edit MIB information about selected ports.

Utilization

Displays the port's utilization information.

Note - Utilization menu does not apply for AT-AR450S devices.

Interface Info

Displays port statistics such as the number of frames received and transmitted on the port, bytes received and transmitted on the port, and port status.

Error Statistics

Displays error statistics for the port.

Spanning Tree Info

Displays the port's spanning tree parameters.

AT-AR400S Series

AT-AR410

This section describes Device Manager menus and operations specific to the AT-AR410 router.

Topics:

- Main Window
- Agent Menu
- Routing Menu
- Bridge Menu
- Frame Relay Menu
- Call List Menu
- Port Menu

Main Window

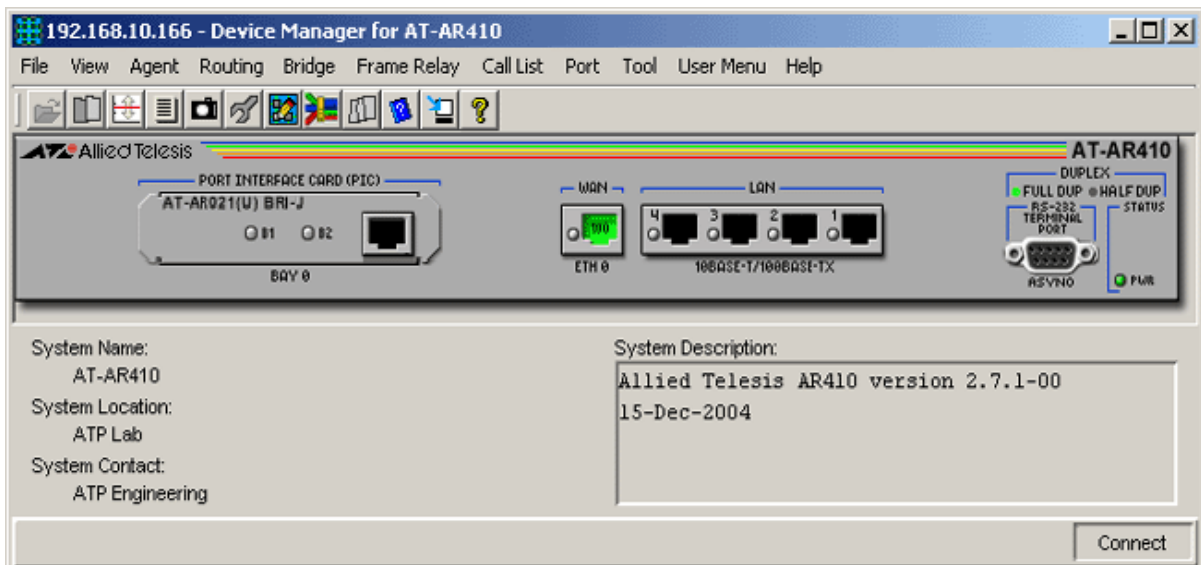

AT-AR410 with PIC installed

Device Manager LEDs for AT-AR410		
LED	State	Description
PWR	Green	The router is receiving power.
DUPLEX	Green	The port is operating at full-duplex.
	Gray	The port is either inactive or is operating at half-duplex.

Note - Please refer to Port Interface Cards (PICs) for the operations and behavior of the Port Interface Cards installed in this device.

Agent Menu

From the Agent menu, you can view and edit the system information for the router, or log into the CLI using Telnet.

System Info

Displays basic system information, including system name, location, contact and description.

File List

Displays a list of the files in the router's flash and NVS file systems.

Config File Name

Displays the file name of the start-up configuration file.

Telnet

Starts a Telnet connection to the router.

WEB Browser

Opens your web browser and connects to the switch's HTTP server.

Note - The web browser can only contact the device if the device has a valid resource file loaded and set, and the HTTP server and GUI on the device are enabled.

Routing Menu

From the Routing menu, you can view and edit information about the router's IP routing functions.

ARP Table

Displays the mapping of IP addresses to MAC addresses (the ARP cache) on the router.

Address Table

Displays the list of IP interfaces and their IP addresses on the router.

Route Table

Displays the IP routing table on the router.

IP Statistics

Displays statistics about IP routing, including the number of IP datagrams received.

ICMP Statistics

Displays ICMP statistics.

Bridge Menu

From the Bridge menu, you can view and edit bridge information such as the forwarding database and spanning tree status. The Bridge submenus are greyed out if bridges not configured.

Discard/Aging Time Info

Displays information about the number of address entries that were learned but discarded because either there was a lack of memory or the entry's aging timer expired.

Spanning Tree Info

Displays spanning tree parameters such as priority and cost.

Frame Relay Menu

From the Frame Relay menu you can view and edit Frame Relay information. The Frame Relay submenus are greyed out if Frame Relay is not configured.

DLCMI Info

Displays DLCMI (Data Link Connection Management Interface) information.

Circuit Info

Displays Frame Relay circuit statistics.

Error Info

Displays information about errors related to the Frame Relay module.

Call List Menu

From the Call List menu, you can view ISDN call information. The Call List submenus are unavailable if the device is not configured for ISDN calls.

Detail Info

Displays ISDN call information such as ISDN number and call direction for active calls.

Active call

Displays information about currently active ISDN calls.

Port Menu

From the Port menu, you can view and edit MIB information about selected ports.

Interface Info

Displays port statistics such as the number of frames received and transmitted on the port, bytes received and transmitted on the port, and port status.

Spanning Tree Info

Displays the port's spanning tree parameters.

AT-AR410

AT-AR700 Series

This section describes Device Manager menus and operations specific to the AT-AR700 Series.

Topics:

- Main Window
- Agent Menu
- Routing Menu
- Bridge Menu
- Frame Relay Menu
- Call List Menu
- Port Menu

Main Window

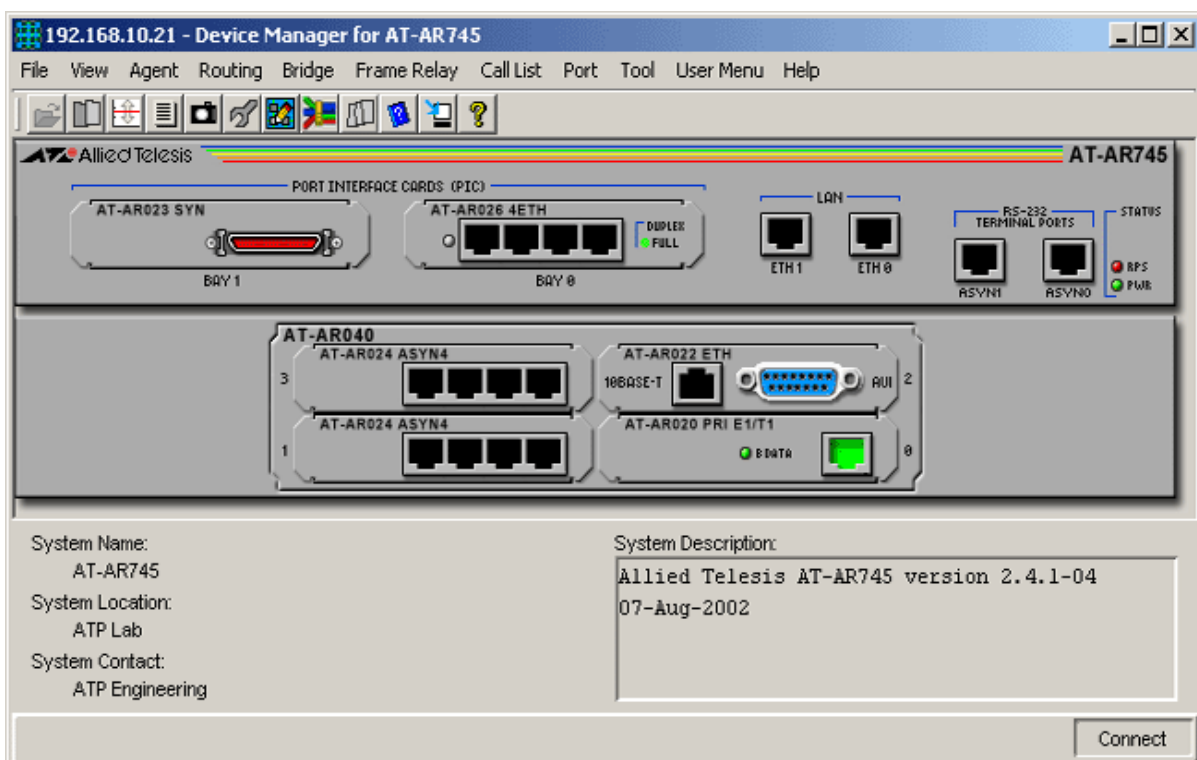

AT-AR745

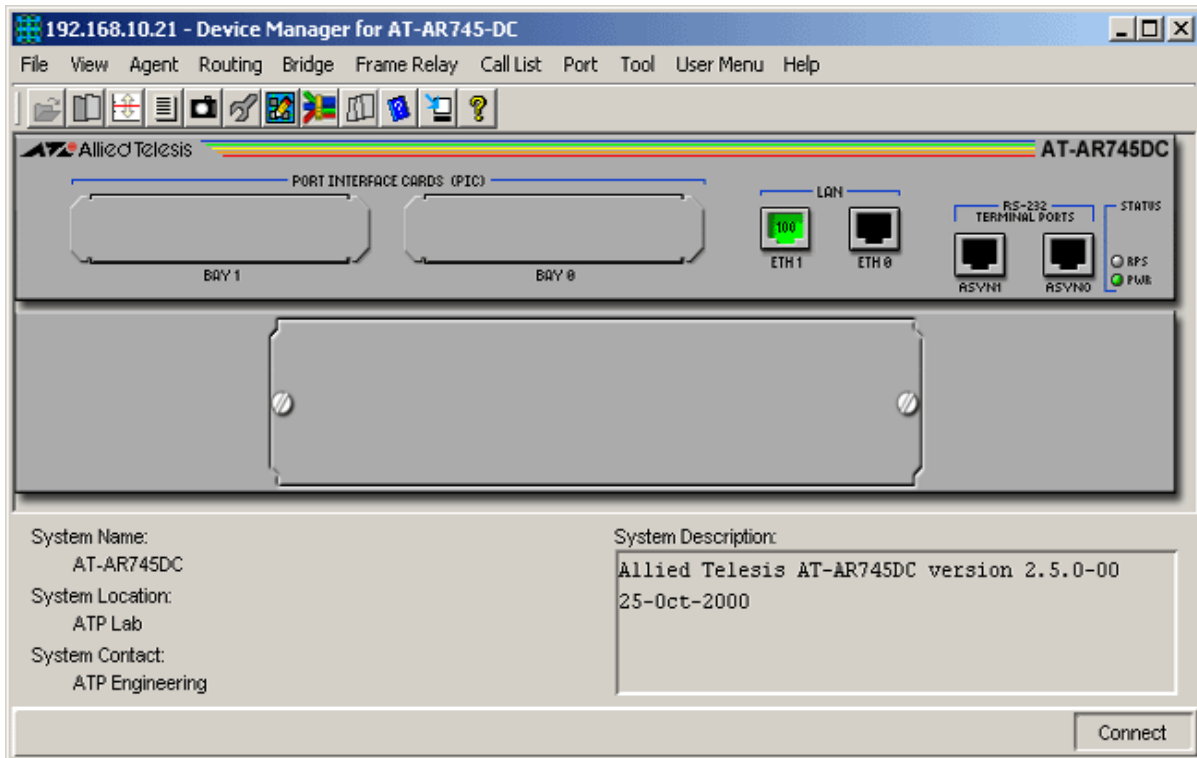

AT-AR745-DC

Device Manager LEDs for AT-AR700 Series		
LED	State	Description
PWR	Green	The router is receiving power from the main power supply unit.
	Red	The main PSU has failed.
RPS	Green	The router is receiving power from the redundant power supply.
	Red	RPS has failed.
	Gray	RPS is not installed or RPS monitoring is disabled.
DUPLEX	Green	The port is operating at full-duplex.

Note - Please refer to Port Interface Cards (PICs) for the operations and behavior of the Port Interface Cards installed in these devices.

Note - Please refer to Network Service Modules (NSMs) for the operations and behavior of the Network Service Modules installed in these devices.

Note - Before hotswapping an NSM, make sure periodic device polling is enabled (File menu -> Properties).

Note - To turn RPS monitoring on or off on the router, enter the command SET SYSTEM RPSMONITOR={ON|OFF} from the command line interface. To see whether RPS monitoring is on, use the command SHOW SYSTEM. To turn on RPS monitoring using SNMP, set the fanAndPsRpsMonitoringStatus variable to on.

Note - The current firmware version does not allow Device Manager to support the RPS LED on the DC models.

Agent Menu

From the Agent menu, you can view and edit the system information for the router, or log into the CLI using Telnet.

System Info

Displays basic system information, including system name, location, contact and description.

File List

Displays a list of the files in the router's flash file system.

Config File Name

Displays the file name of the start-up configuration file.

Telnet

Starts a Telnet connection to the router.

WEB Browser

Opens your web browser and connects to the switch's HTTP server.

Note - The web browser can only contact the device if the device has a valid resource file loaded and set, and the HTTP server and GUI on the device are enabled.

Routing Menu

From the Routing menu, you can view and edit information about the router's IP routing functions.

ARP Table

Displays the mapping of IP addresses to MAC addresses (the ARP cache) on the router.

Address Table

Displays the list of IP interfaces and their IP addresses on the router.

Route Table

Displays the IP routing table on the router.

IP Statistics

Displays statistics about IP routing, including the number of IP datagrams received.

ICMP Statistics

Displays ICMP statistics.

Bridge Menu

From the Bridge menu, you can view and edit bridge information such as the forwarding database and spanning tree status. The Bridge submenus are greyed out if bridges are not configured.

Discard/Aging Time Info

Displays information about the number of address entries that were learned but discarded because either there was a lack of memory or the entry's aging timer expired.

Spanning Tree Info

Displays spanning tree parameters such as priority and cost.

Frame Relay Menu

From the Frame Relay menu you can view and edit Frame Relay information. The Frame Relay submenus are greyed out if Frame Relay is not configured.

DLCMI Info

Displays DLCMI (Data Link Connection Management Interface) information.

Circuit Info

Displays Frame Relay circuit statistics.

Error Info

Displays information about errors related to the Frame Relay module.

Call List Menu

From the Call List menu, you can view ISDN call information. The Call List submenus are greyed out if an ISDN interface is not installed, and the device is not configured to use ISDN.

Detail Info

Displays ISDN call information such as ISDN number and call direction for active calls.

Active call

Displays information about currently active ISDN calls.

Port Menu

From the Port menu, you can view and edit MIB information about selected ports.

Interface Info

Displays port statistics such as the number of frames received and transmitted on the port, bytes received and transmitted on the port, and port status.

Error Statistics

Displays error statistics for the port.

Spanning Tree Info

Displays the port's spanning tree parameters. This option is greyed out if bridge ports are not configured on the router at the time Device Manager is started.

AT-AR700 Series

AT-AR700S Series

This section describes Device Manager menus and operations specific to the AT-AR700S Series routers.

Topics:

- Main Window
- Agent Menu
- Routing Menu
- LAN/WAN Menu
- Availability Menu
- Security Menu
- RMON Menu
- Port Menu

Main Window

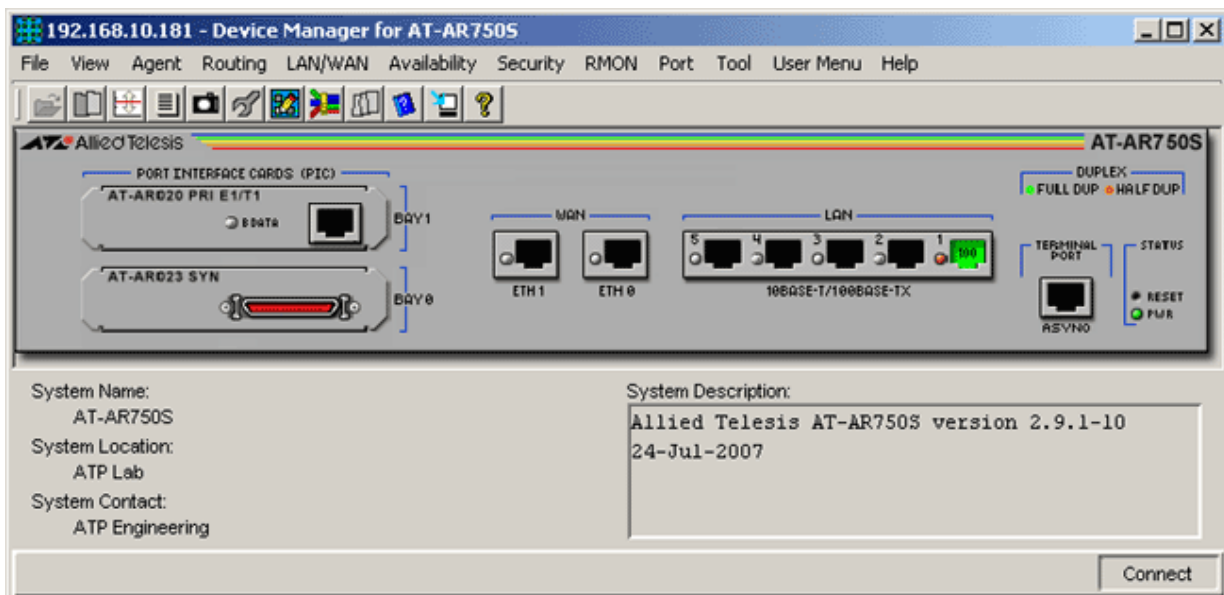

AT-AR750S

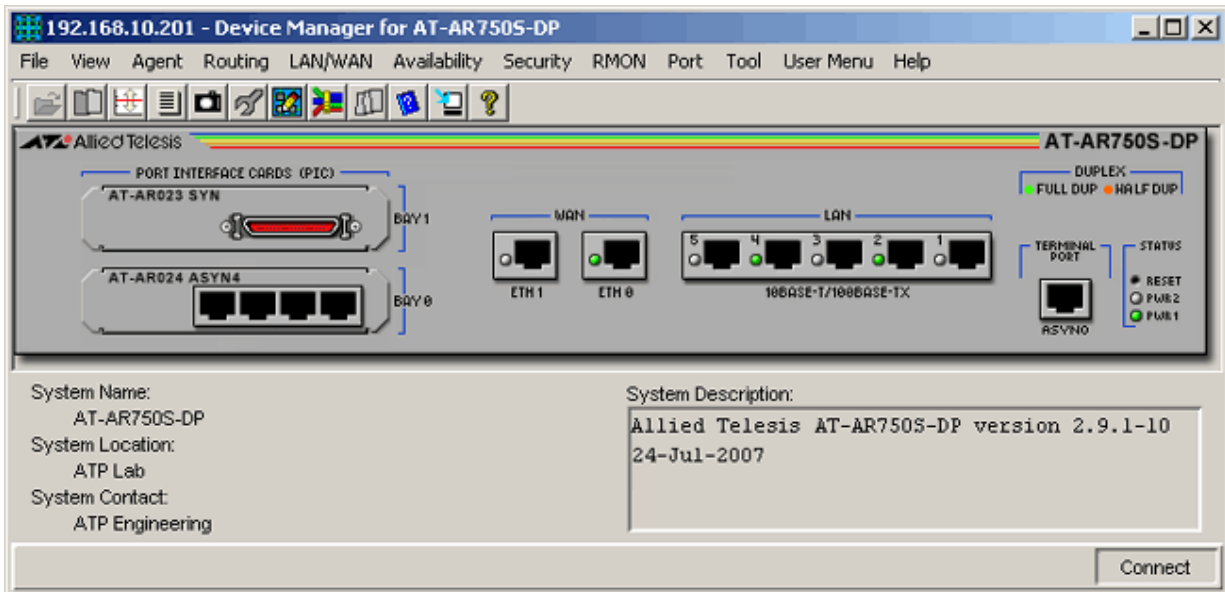

AT-AR750S-DP

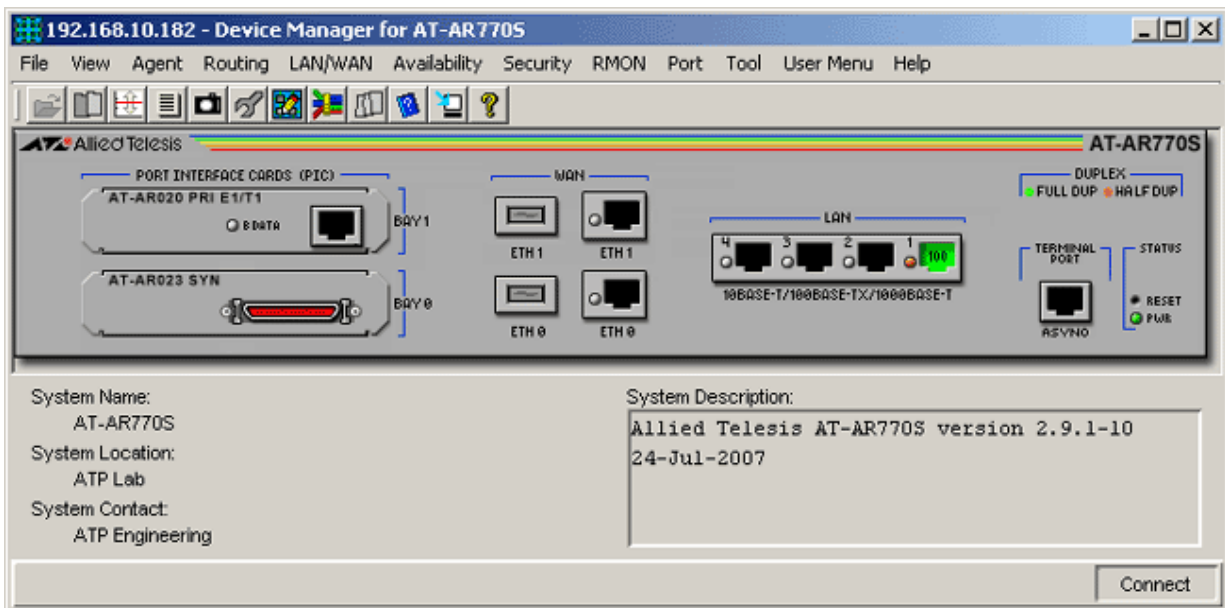

AT-AR770S

Note - AT-AR770S: DUP LEDs of active ports will always be orange regardless of the actual duplex mode of the ports. This is because the current firmware version always returns a half-duplex value for the Duplex Mode parameter of these ports.

Device Manager LEDs for the AT-AR700S Series		
LED	State	Description
PWR	Green	The router is receiving power from the main power supply unit.
DUPLEX	Green	The port is operating at full-duplex.
	Gray	The port is either inactive or is operating at half-duplex.

Note - Please refer to Port Interface Cards (PICs) for the operations and behavior of the Port Interface Cards installed on these devices.

Agent Menu

From the Agent menu, you can view and edit the system information for the router, or log into the CLI using Telnet.

System Info

Standard

Displays basic system information, including system name, location, contact and description.

Enterprise

CPU Utilization

Displays information about the CPU utilization over different periods of time.

Temperature

Displays information about the temperature monitored by the temperature sensors in the device.

Note - The current firmware version does not allow the Temperature Threshold parameter to be configured.

Host Resources

General System Info

Displays general information about the host resources.

Note - Device Manager does not handle objects of type OCTET STRING correctly. As a result, the Time and Date parameter will display a sequence of bytes in hexadecimal format instead of the actual date and time of day.

Note - The Time and Date and Initial Load Parameter parameters are implemented as 'read-only'.

Logical Storage Areas

Displays resource information about the storage devices.

Note - The Storage Size parameter is implemented as 'read-only'.

Devices

Displays resource information about the devices installed in the host.

Hardware Info

Total Boards

Displays the number of boards that are currently installed.

Board Info

Displays basic information on the boards that are currently installed.

Slot Info

Displays information on the Power Supply Bay slots.

Physical Interfaces

Displays information about the interfaces found in the device.

Firmware Info

Install Configurations

Displays information about the Software release currently loaded in the device.

Note - The current firmware version returns a 'noSuchName' value for the Release File Exists? and Patch File Exists? parameters.

Install History

Displays information about the install history.

Configuration File

Displays the Configuration file name.

Note - The Startup Config and Save Running Config parameters accept inputs from 4 to 38 characters only.

Release Licenses

Displays a list of software releases installed on the switch.

Note - The current firmware version does not allow any of the parameters under this table to be configured.

File System

Total Files

Displays the total number of files stored in the device.

File List

Displays a list of the files in the switch's file system.

Loader

Load Status

Displays the status of the device loader.

Load Parameters

Displays information about the files to be loaded.

LLDP Configuration

General Config

Displays basic LLDP configuration.

Port Config

Displays LLDP configuration for each port.

Note - The current firmware version returns a 'noSuchName' value for the Port Number parameter.

Note - Device Manager does not handle objects of type BITS correctly. As a result, the TLVs Tx Enable parameter will not be configurable and will display an 8-bit binary string instead of the actual TLV types allowed. However, the TLV types allowed can still be determined by looking at the bits that are on from left to right:

- Bit 0 - Port Description
- Bit 1 - System Name
- Bit 2 - System Description
- Bit 3 - System Capabilities

LLDP Statistics

Remote Tables

Displays statistics for the LLDP remote tables.

Port Tx

Displays statistics for LLDP frames transmitted.

Note - The current firmware version returns a 'noSuchName' value for the Port Number parameter.

Port Rx

Displays statistics for received LLDP frames.

Note - The current firmware version returns a 'noSuchName' value for the Port Number parameter.

Local System Data

General Info

Displays information about the local LLDP system.

Port Info

Displays information on the LLDP of local ports.

Note - The current firmware version returns a 'noSuchName' value for the Port Number parameter.

Management Addresses

Displays management addresses of the local LLDP system.

Note - The current firmware version returns the value 'NULL' for the OID parameter.

Reset Cold

Initiates a cold restart on the switch.

Reset Warm

Initiates a warm restart on the switch.

Reset Info

Displays information about the restart.

Telnet

Starts a Telnet connection to the switch.

WEB Browser

Opens your web browser and connects to the switch's HTTP server.

Routing Menu

From the Routing menu, you can view and edit information about the router's IP routing functions.

IP

ARP Table

Displays the ARP cache on the switch.

Note - The Physical Address and Mapping Type parameters are implemented as 'read-only'.

Address Table

Displays the list of IP interfaces on the switch.

Route Number

Displays the IP routing number on the switch.

Route Table

Displays the IP routing table on the switch.

Note - The current firmware version returns the value 'NULL' for the Routing Protocol MIB parameter.

Note - The following parameters are implemented as 'read-only':

- Destination Port Number
- Routing Type
- Next Hop AS Number
- Destination Metric 1
- Destination Metric 2
- Destination Metric 3
- Destination Metric 4
- Destination Metric 5
- Row Status

IP Statistics

Displays statistics about IP, such as the number of IP datagrams received.

UDP

Listener Info

Displays UDP listener information.

UDP Statistics

Displays UDP statistics.

TCP

Connection Info

Displays TCP connection-specific information.

Note - The Connection Status parameter is implemented as 'read-only'.

TCP Statistics

Displays TCP statistics.

ICMP Statistics

Displays ICMP statistics.

DHCP Ranges

Displays information about the DHCP module.

BGP

General Info

Displays information about the BGP module.

Peer Info

Displays BGP Peer information.

Note - The current firmware version does not allow the following parameters to be configured:

- Connect Retry Interval
- Configured Hold Time
- Configured Keep Alive
- Min AS Origination Interval
- Min Route Advertisement Interval

Path Attributes

Displays the BGP path attributes.

LAN/WAN Menu

From the LAN/WAN menu, you can view and edit information for the LAN/WAN such as the frame relay and ISDN-related information. The submenus are unavailable if the proper PICs are not installed.

Bridging

Forwarding Database

Displays the Forwarding Database table as returned by the device.

Discard/Aging Time Info

Displays information about the number of address entries that were learned but discarded for reasons such as lack of memory or the entry's aging timer.

Spanning Tree Info

Displays spanning tree parameters such as priority and cost.

Statistics

Displays statistics about frames received/transmitted on the switch port.

Basic Bridge Info

Displays basic bridge information.

Bridge Port Info

Displays bridge port information.

Note - The current firmware version returns the value 'NULL' for the Circuit parameter.

ISDN

Call Details

Displays ISDN call information such as ISDN number and call direction for active calls.

Note - The Remote Call parameter does not allow input values that contain hyphens.

Note - If the In CLI (Calling Line Info) Search parameter is set to 'list', the In CLI (Calling Line Info) List Check parameter gives the index of the CLI list to search. The value of CLI list indices ranges from 1 to 100. The value 0 is returned if the In CLI (Calling Line Info) Search parameter is not set to 'list'. When the In CLI (Calling Line Info) List Check parameter is set to 0, the In CLI (Calling Line Info) Search parameter is internally set to 'off'. Subsequently setting it to a non-zero value will set the In CLI (Calling Line Info) Search parameter to 'list'. Note that when using the command line interface, CLI List indices range from 0 to 99, but when using Device Manager, they range from 1 to 100. This is because SNMP will not allow a table index to have the value 0, and the command line usage of indices from 0 to 99 is too well established to change.

Note - If the In CLI (Calling Line Info) Check parameter is set to 'present' or 'required', the In CLI (Calling Line Info) Check List parameter gives the index of the CLI list to check against. The value of CLI list indices ranges from 1 to 100. The value 0 means that no list to check against is defined and the check immediately fails. Note that when using the command line interface, CLI list indices range from 0 to 99, but when using Device Manager, they range from 1 to 100. This is because SNMP will not allow a table index to have the value 0, and the command line usage of indices from 0 to 99 is too well established to change.

Note - The PPP Template parameter specifies the PPP template to use when creating dynamic PPP interfaces for calls generated. The value 33 represents a default PPP template while the values 1 to 32 represent PPP templates that are currently defined in the router. Note that when using the command line interface, PPP template indices range from 0 to 31, but when using Device Manager, they range from 1 to 32. This is because SNMP will not allow a table index to have the value 0.

CLI List

Displays the Calling Line Information list.

Active Calls

Displays information about currently active ISDN calls.

Call Log

Displays the call logs.

Call Detail Attachments

Displays call detail attachment information.

B Channel Attachments

Displays B Channel attachment information.

BRI Interfaces

Displays BRI interface information.

BRI Channels

Displays BRI channels information.

PRI Interfaces

Displays PRI interface information.

PRI Channels

Displays PRI channels information.

Frame Relay

DLC Management Interfaces

Displays DLCMI (Data Link Connection Management Interface) information.

Note - The DLCMI Status and Row Status parameters are not applicable to the AT-AR700S series and should be ignored.

Note - The following parameters are implemented as 'read-only':

- DLCMI State
- Address Type
- Address Length
- Polling Interval of Successive Status
- Polling Interval of Full Status Enquiry
- Error Threshold
- Monitored Error Events
- Max Supported VC Numbers
- Multicast Type

Virtual Circuits

Displays Frame Relay circuit statistics.

Note - The following parameters are not applicable to the AT-AR700S series and should be ignored:

- Multicast Type
- Type
- Discards
- Received DEs
- Sent DEs
- Logical Interface Index
- Row Status

Note - The following parameters are implemented as 'read-only':

- State
- CIR
- Maximum Line Speed
- Throughput

Errors

Displays information about errors related to the Frame Relay module.

Note - The Faults and Fault Time parameters are not applicable to the AT-AR700S series and should be ignored.

DSI

DSI Config

Displays DSI configuration.

Note - The current firmware version returns a 'noSuchName' value for the Port Number parameter.

Note - The following parameters are implemented as 'read-only':

- Line Type
- Line Coding
- Send Code
- Circuit ID
- Loopback Config
- Signal Mode
- Transmit Clock Source
- Facilities Data Link
- Line Length
- Change Status Trap
- Channelization

Near-End

Current 15-Min Interval Statistics

Displays near-end DSI statistics every 15 minutes.

Statistics for Past 24 Hours

Displays near-end DSI statistics for the past 24 hours.

Cumulative Statistics

Displays accumulated near-end DSI statistics.

Far-End

Current 15-Min Interval Statistics

Displays far-end DSI statistics every 15 minutes.

Statistics for Past 24 Hours

Displays far-end DSI statistics for the past 24 hours.

Cumulative Statistics

Displays accumulated far-end DSI statistics.

Availability Menu

From the Availability menu you can view and edit Server Load Balancing and Ping Polling information.

Server Load Balancing

General Info

Displays basic server load balancing information.

Resources

Displays server load balancing resources information.

Resource Pools

Displays server load balancing resource pools information.

Virtual Balancers

Displays virtual balancers information.

Affinity Tables

Displays load balancer affinities information.

Open TCP Connections

Displays open TCP connections information.

Ping Polling

Ping Status

Displays the status of the Ping polling.

Note - The current firmware version does not allow the Ping Status parameter to be configured.

Ping Parameters

Displays basic information of the Ping module.

Note - Valid MIB Set values for the Number of Packets parameter should range from 0-4294967595. However, the current firmware version allows the user to enter negative values as well. Furthermore, attempting to set the parameter to 0 will result in the error message: "The error occurred with 'Set' operation. Error: bad value."

Note - The current firmware version accepts values in the range [0-4294967595] inclusive for the Number of Packets and Time Interval parameters.

Note - Valid MIB Set values for the Timeout parameter should range from 1 to 65535. However, the current firmware version allows the user to enter values in the range [-65535 to -1, 1 to 65535] inclusive. Attempting to enter values greater than 65535 will cause the new value to be converted to its equivalent wrap-around value; i.e., 65536 will become 0, 65537 will become 1, and so on.

Note - The current firmware version does not allow the Address parameter to be configured.

Ping Statistics

Displays statistics of the Ping polling.

Security Menu

From the Security menu, you can view and edit port access entity information such as the PAE port information and the Supplicant PAE information.

Port-based Authentication

Authentication Status

Displays the status of the port-based authentication.

PAE Port Info

Standard

Displays standard PAE port information.

Note - The current firmware version returns a 'noSuchName' value for the Port Number parameter.

Note - Device Manager does not handle objects of type BITS correctly. As a result, the Capabilities parameter will display an 8-bit binary string instead of the actual PAE functionality supported. However, the PAE functionality supported can still be determined by looking at the bits that are on from right to left:

- Bit 0 - Authenticator
- Bit 1 - Supplicant

Enterprise

Displays enterprise PAE port information.

Note - Device Manager does not handle objects of type BITS correctly. As a result, the Capabilities parameter will display an 8-bit binary string instead of the actual PAE functionality supported. However, the PAE functionality supported can still be determined by looking at the bits that are on from right to left:

- Bit 0 - Authenticator
- Bit 1 - Supplicant

Authenticator PAE Info

Standard

Displays standard authenticator PAE information.

Note - The current firmware version returns a 'noSuchName' value for the Port Number parameter.

Note - The Administrative Controlled Directions and Key Transmission Status parameters are implemented as 'read-only'.

Enterprise

Displays enterprise authenticator PAE information.

Authenticator PAE Statistics

Standard

Displays standard statistics for the PAE Authenticator.

Note - The current firmware version returns a 'noSuchName' value for the Port Number parameter.

Enterprise

Displays enterprise statistics for the PAE Authenticator.

Supplicant PAE Info

Displays supplicant PAE information.

Note - The current firmware version returns a 'noSuchName' value for the Port Number parameter.

Supplicant PAE Statistics

Displays the statistics for the PAE supplicant.

Note - The current firmware version returns a 'noSuchName' value for the Port Number parameter.

MAC-based Authentication

PAE Port Info

Displays PAE port information.

Note - The Initialize parameter is implemented as 'read-only'.

Authenticator PAE Info

Displays authenticator PAE information.

Firewall Session Statistics

Displays the statistics for the firewall sessions.

RMON Menu

From the RMON menu you can view and edit the RMON MIB.

Statistics

Displays traffic statistics in the network segment attached to each port.

History Control Table

Displays the RMON History table.

Alarm Table

Displays the RMON Alarm table.

Event Table

Displays the RMON Event table.

Event Log

Displays the RMON Event log.

Port Menu

From the Port menu, you can view and edit MIB information about selected ports.

Utilization

Displays the port's utilization information.

Interface Info

Displays port statistics such as the number of frames received and transmitted on the port, bytes received and transmitted on the port, and port status. This table also displays high-capacity port statistics including received and transmitted unicast/multicast/broadcast packets on the port, link up/down trap and port speed.

Note - The current firmware version returns a 'noSuchName' value for the Port Alias and Counter Discontinuity Time parameters.

Note - Valid MIB Set values for the Administration Status parameter are 'up' and 'down' only.

Note - The Promiscuous Mode parameter is implemented as 'read-only'.

Detail Info

Displays detailed port information such as duplex mode.

Note - AT-AR770S: The current firmware version always returns 'half-duplex' for the Duplex Mode parameter regardless of the actual duplex mode of the port.

Error Statistics

Displays error statistics.

Note - The Ethernet Chip Set, Symbol Errors and Duplex Status parameters are not applicable to the AT-AR700S series and should be ignored.

Spanning Tree Info

Displays the port's spanning tree parameters.

Note - Valid MIB Set values for the Port Path Cost parameter is in the range [1-65535] inclusive.

MAU Info

Displays interface-related MAU information for the port.

Note - The MAU Type List Bits and HC False Carriers parameters are not applicable to the AT-AR700S series and should be ignored.

Note - The MAU Status and Default MAU Type parameters are implemented as 'read-only'.

MAU Negotiation Info

Displays the MAU's auto-negotiation settings and its status.

Note - The following parameters are not applicable to the AT-AR700S series and should be ignored:

- Capability Bits
- Advertised Bits
- Received Bits
- Remote Fault Advertised
- Remote Fault Received

Note - The Administration Status, Advertised Negotiation Capability and Restart parameters are implemented as 'read-only'.

Enable

Enables the port.

Disable

Disables the port.

Advanced Layer 2 Switches

AT-8500 Series

This section describes Device Manager menus and operations specific to the AT-8500 Series.

Topics:

- Main Window
- Agent Menu
- Routing Menu
- Bridge Menu
- RMON Menu
- Port Menu
- Stacking Menu
- Expansion Module Notes

Main Window

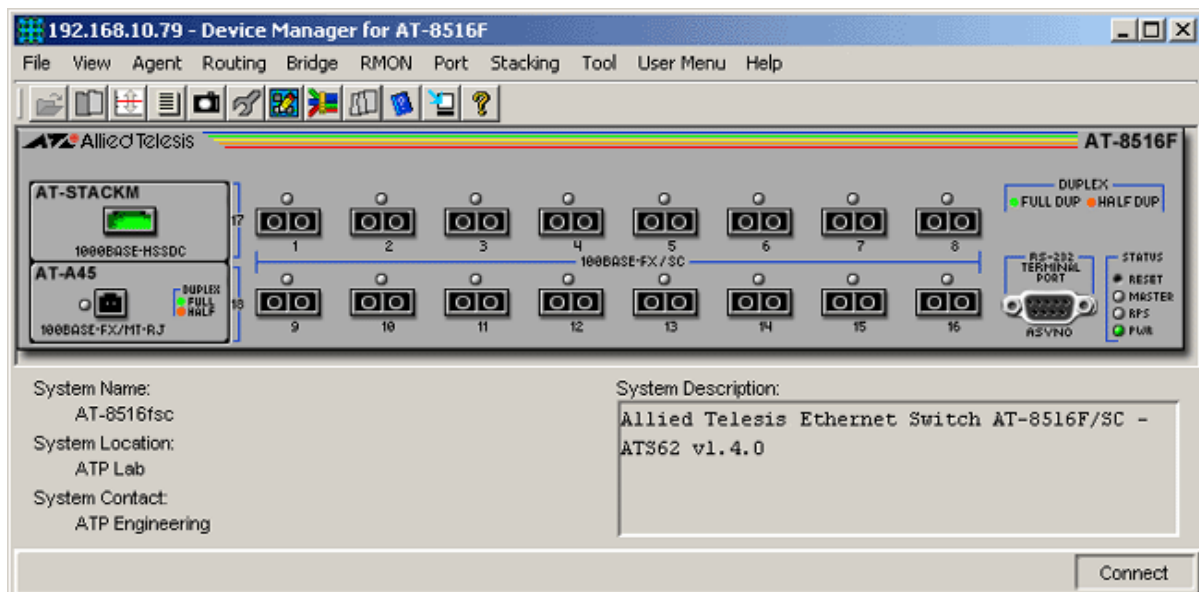

AT-8516F/SC

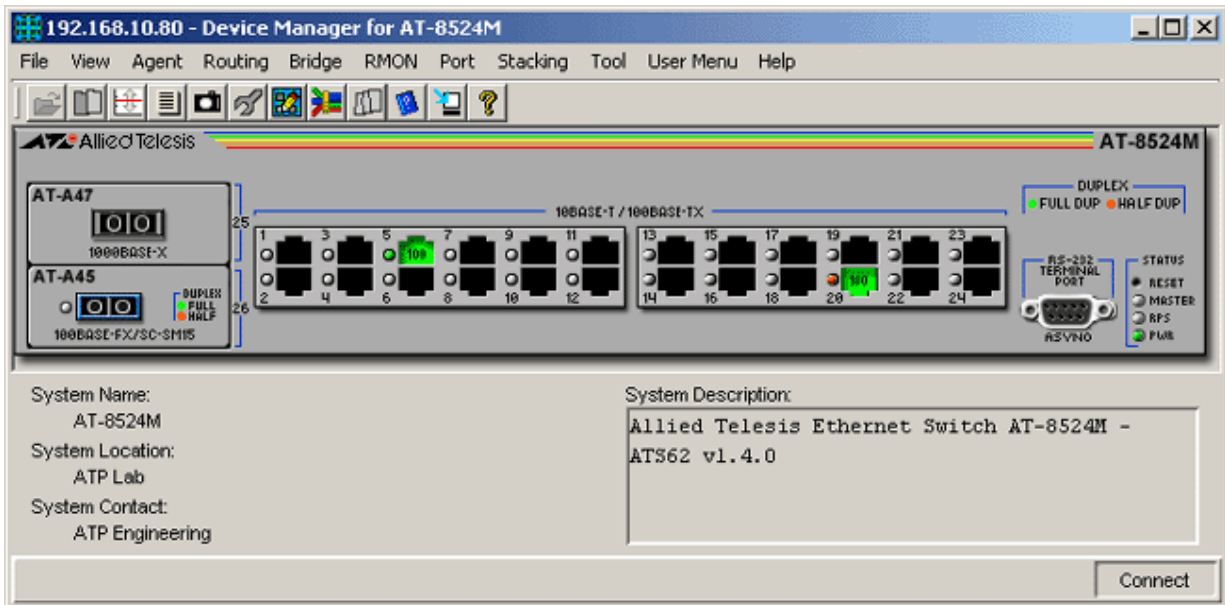

AT-8524M

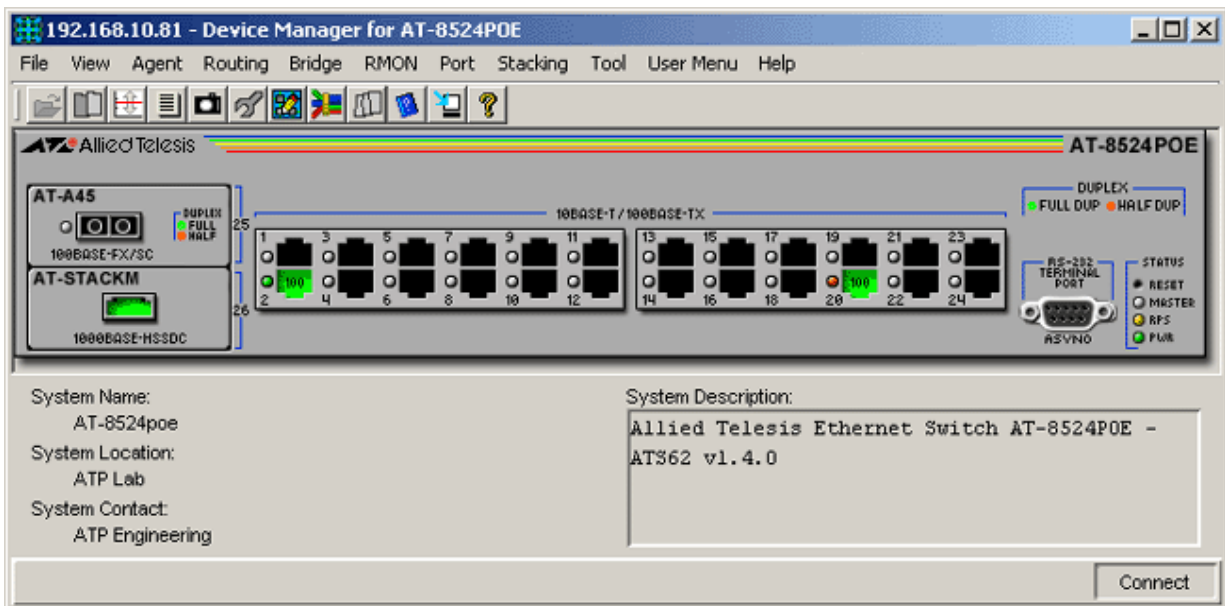

AT-8524POE

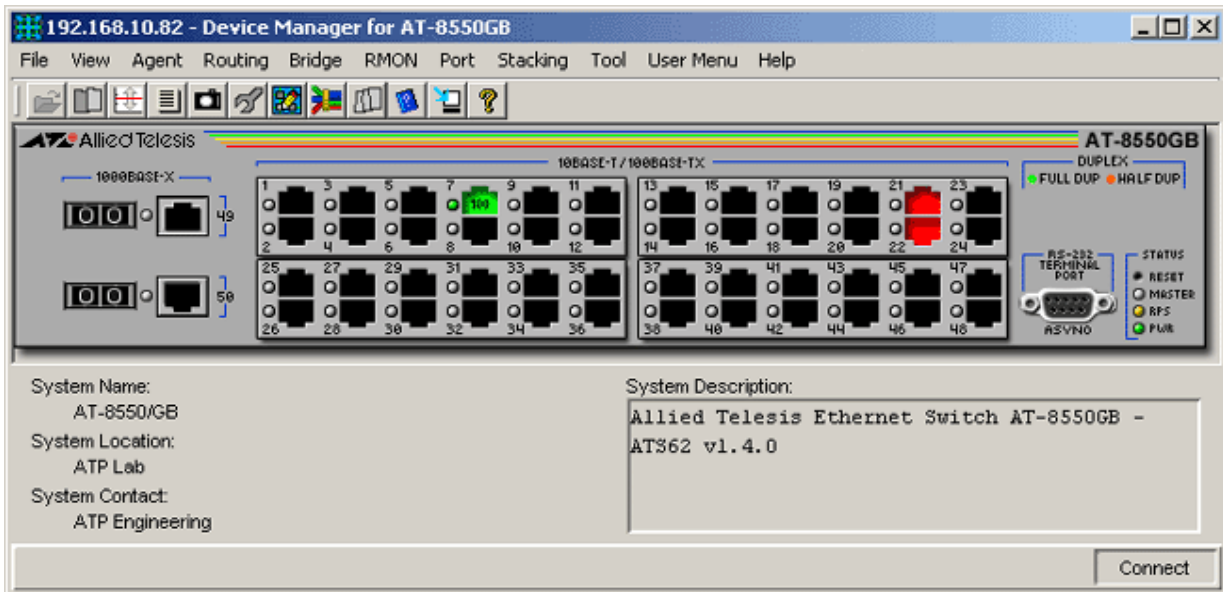

AT-8550GB

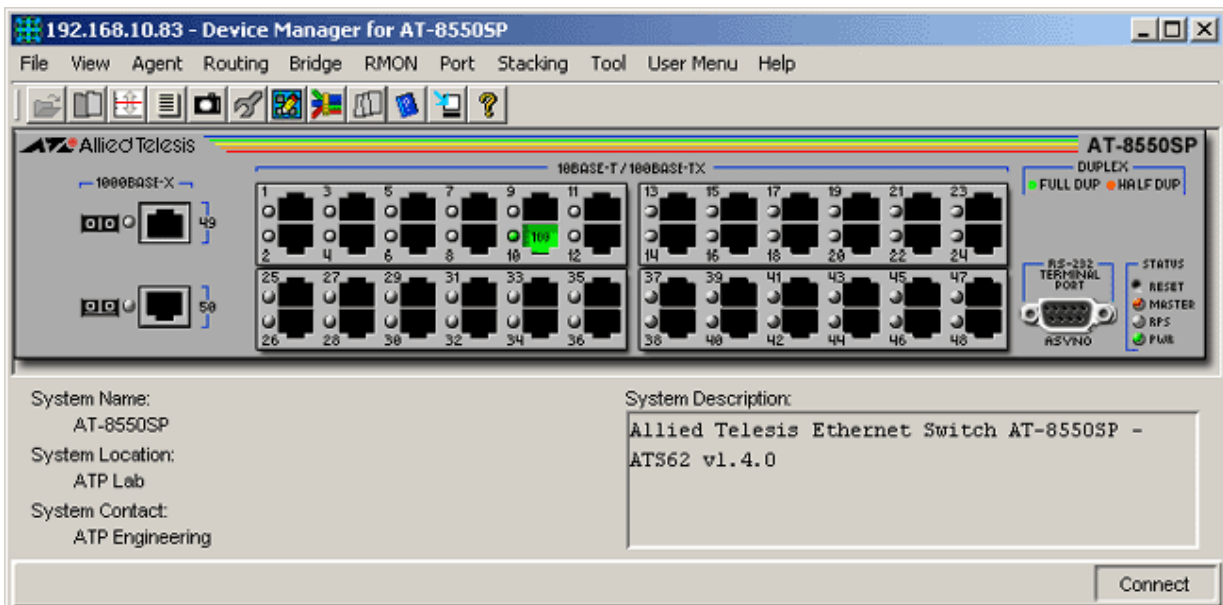

AT-8550SP

Device Manager LEDs for AT-8500 Series

LED	State	Description
PWR	Green	The switch is receiving power.
MASTER	Orange	The switch is the master switch of an enhanced stack.
	Gray	The switch is a slave switch or is not a member of an enhanced stack.

Device Manager LEDs for AT-8500 Series		
LED	State	Description
DUPLEX	Green	The port is operating in full-duplex mode.
	Orange	The port is operating in half-duplex mode.
RPS	Green	An optional redundant power supply is connected to the switch and is turned on.
	Gray	There is no redundant power supply connected to the switch.
	Yellow	An optional redundant power supply is connected to the switch but is turned off.

Note - Please refer to Uplink Modules for the operations and behaviour of the expansion modules installed on these devices.

Note - When connecting to a slave switch, Device Manager does not automatically replace the master switch image in the main window with the slave switch image. The same is true when returning to the master switch from the slave switch. To view the updated image, click on the Refresh option under the Agent menu.

Note - AT-8550SP: If a copper SFP is inserted in either of the SFP module expansion slots, status information will be reflected on its corresponding redundant RJ-45 port image regardless of whether it is the RJ-45 or the SFP port that is actually in operation.

Note - The SNMP Client on the device may take a while to respond or may stop responding altogether after several SNMP commands have already been issued. When this happens, it may take a while for device information to be displayed in Device Manager. Error messages may also be encountered during Get MIB Value and Set MIB Value operations.

Agent Menu

From the Agent menu, you can view and edit the system information for the device, or log into the CLI using Telnet.

System Info

Displays basic system information, including system name, location, contact and description.

Note - The current firmware version allows the user to enter up to 38 characters for the System Location parameter.

Note - Configuring the System Contact, System Name and System Location parameters may sometimes result in the error message: "The error occurred with 'Set' operation. Error: gen Error." However, the values are still set successfully.

Network Info

Displays network-related information such as the addresses of the default gateway and the agents.

Note - The current firmware version returns an initial value of '???(0)' for the Action parameter.

Note - Valid MIB Set values for the Action parameter are 'reset' and 'defaultConfig'. The 'saveConfig' value is nonfunctional in the current firmware release and selecting it may cause the SNMP client on the device to stop responding to SNMP commands. To save changes made via SNMP to the switch's configuration file, use one of the other management interfaces (i.e. menu, command line, web browser).

Device Info

Displays general information about the switch.

Note - AT-8550SP: The current firmware version returns a value of 'other' for the Uplink A Port Type and Uplink B Port Type parameters if copper SFPs are inserted in the SFP module expansion slots.

Uplink Info

Displays uplink information of the switch.

Note - The current firmware version returns 'not present' for the Type parameter.

MAC Address Table

Displays a list of static MAC addresses configured on the switch.

Note - The MIB (atiStackSwitch.mib v2.28) supported by the current firmware version defines the Module ID, Port ID, and Port List parameters as "read-write". As a result, Device Manager displays these parameters as configurable objects. However, attempting to configure these parameters will show that the firmware does not accept any value.

Note - The only valid MIB Set value for the Status parameter is 'destroy'. Attempting to set this parameter to any other value may result in the value being ignored or the error message: "The error occurred with 'Set' operation. Error: bad value."

Reset

Resets the switch.

Telnet

Starts a Telnet connection to the switch.

WEB Browser

Connects to the switch's HTTP server.

Routing Menu

From the Routing menu, you can view and edit information about the switch's routing functions.

IP

ARP Table

Displays the ARP cache on the switch.

Address Table

Displays the list of IP interfaces on the switch.

Route Table

Displays the IP routing table on the switch.

IP Statistics

Displays statistics about IP routing, including the number of IP datagrams received.

Note - The current firmware version does not allow the Default TTL parameter to be configured.

UDP

Listener Info

Displays UDP listener information.

UDP Statistics

Displays UDP statistics.

TCP

Connection Info

Displays TCP connection-specific information.

Note - The current firmware version does not allow the Connection Status parameter to be configured.

TCP Statistics

Displays TCP statistics.

ICMP Statistics

Displays ICMP statistics.

Bridge Menu

From the Bridge menu, you can view and edit bridge information such as the forwarding database and the spanning tree status.

Forwarding Database

Note - Changes to the Forwarding Database table caused by dynamic network topology/configuration changes will not be reflected unless the device is restarted.

Standard View

Displays the Forwarding Database table as returned by the device.

Enhanced View

Displays the Forwarding Database table on a per port basis. User can select a port or group of ports to view its corresponding Forwarding Database entries.

Discard/Aging Time Info

Displays information about the number of address entries that were learned but discarded because either there was a lack of memory or the entry's aging timer expired.

Spanning Tree Info

Displays spanning tree parameters such as priority and cost.

Note - When the Spanning Tree Status parameter is set to 'enabled' and the Spanning Tree Version parameter is set to 'mstp', the current firmware version continues to return a value of 'forwarding' for the Port STP State parameter of blocking ports. As a result, blocking ports will remain green and will not turn to yellow.

Statistics

Displays statistics about frames received/transmitted on the switch port.

RMON Menu

From the RMON menu you can view and edit the RMON MIB.

Statistics

Displays traffic statistics in the network segment attached to each port.

History Control Table

Displays the RMON History table.

Note - The current firmware version is unable to provide History Control Table information. As a result, the following error message appears: "Failed to get MIB data."

Alarm Table

Displays the RMON Alarm table.

Event Table

Displays the RMON Event table.

Event Log

Displays the RMON Event log.

Port Menu

From the Port menu, you can view and edit MIB information about the port.

Utilization

Displays the port's utilization information.

Interface Info

Standard

Displays port statistics such as the number of packets received and transmitted on the port, bytes received and transmitted on the port and port status. This table also displays high-capacity port statistics including received and transmitted unicast/multicast/broadcast packets on the port, link up/down trap and port speed.

Note - Valid MIB Set values for the Administration Status parameter are 'up' and 'down'. Attempting to set this parameter to any other value will result in the error message: "The error occurred with 'Set' operation. Error: bad value."

Note - The current firmware version does not allow the Promiscuous Mode and Port Alias parameters to be configured.

Additional Info

Displays port statistics such as the number of frames received and transmitted on the port, bytes received and transmitted on the port and port status.

Error Statistics

Displays error statistics.

Detail Info

Displays detailed port information such as duplex mode.

Note - Valid MIB Set values for the Port Flow Control parameter are 'disable' and 'enable'. Attempting to set Port Flow Control to 'unknown' will cause the parameter to be set to 'enable'.

Note - Valid MIB Set values for the Port Back Pressure parameter are 'disable' and 'enable'. Attempting to set Port Back Pressure to 'unknown' will cause the parameter to be set to 'enable'.

Note - The Port CoS/QoS Priority parameter is not applicable to the AT-8500 series and should be ignored.

Note - AT-8550 : The current firmware version allows the Port Speed and Mode parameter of a GBIC or SFP port to be set to '10Mbps full-duplex' or '100Mbps full-duplex' even if the GBIC or SFP module inserted is not capable of 10/100 Mbps connectivity.

Note - AT-8550 : The 10/100/1000Base-T twisted pair ports cannot be manually set to 1000Mbps. However, the current firmware version allows the Port Speed and Mode parameter for these ports to be set to '1Gbps full-duplex' or '1Gbps half-duplex'.

Note - When the Port Speed and Mode parameter is set to 'auto sense', the Port MDIO parameter is automatically set to 'mdi' and cannot be changed to 'auto mdix'.

Note - AT-8516F/SC: The Port Speed and Mode parameter of the 100Base-FX/SC fixed ports can only be set to '100Mbps full-duplex'.

CoS

Displays Class of Service parameters and allows you to configure CoS for a port, change the default mappings of CoS priorities to egress priority queues and configure a scheduling method for Class of Service.

Note - Valid MIB Set values for the CoS Queue parameters are:

- egress-queue-0
- egress-queue-1
- egress-queue-2
- egress-queue-3

Attempting to set these parameters to any other value will result in the error message: "The error occurred with 'Set' operation. Error: bad value."

Note - The current firmware version accepts values in the range [1-255] inclusive for the Queue Weight parameters.

QoS

Displays Quality of Service parameters and allows you to configure Flow Groups, Traffic Classes, and Policies.

Flow Groups

Displays Flow Group parameters used to group similar traffic flows together.

Note - The current firmware version accepts up to 32 characters for the Description parameter. NULL values are not allowed.

Traffic Classes

Displays Traffic Class parameters used to provide most of the QoS controls.

Note - The current firmware version accepts up to 32 characters for the Description parameter. NULL values are not allowed.

Policies

Displays Policy parameters.

Note - The current firmware version accepts up to 32 characters for the Description parameter. NULL values are not allowed.

Note - The Redirect Port parameter is cleared of its value each time the switch is restarted.

Note - The current firmware version does not allow the Ingress Port List and Egress Port List parameters to be set to NULL.

Enable

Enables the port.

Disable

Disables the port.

Port Mirroring

Displays Port Mirroring parameters and allows you to create/delete a port mirror.

Note - The Mirroring Source Module, Mirroring Source Port and Mirroring Destination Module parameters are not applicable to the AT-8500 series and should be ignored.

Note - Setting the Port Mirroring Status parameter to 'enabled' without setting the Mirroring Destination Port parameter to a valid value first will result in the error message "The error occurred with 'Set' operation. Error: gen Error". However, the value 'enabled' is still set successfully.

Note - The current firmware version does not allow the Mirroring Destination Port parameter to be set to 0.

Note - The current firmware version does not allow the Mirroring Source Port (Ingress) and Mirroring Source Port (Egress) parameters to be set to NULL.

Note - The current firmware version does not allow the Port Mirroring Status parameter to be set to 'enabled' if, upon device startup, the Port Mirroring feature is disabled.

MAC Address Security

Displays MAC Address Security parameters and allows you to set the security level for dynamic and static MAC addresses learned and assigned to a port.

Intrusion Attack

Displays the VLAN ID and the MAC Address of each port.

Note - The VLAN ID and MAC Address parameters do not return valid values. They return "noSuchName.", "No such instance" or NULL.

DoS Defense

Displays DoS Defense parameters and allows you to enable/disable a defense mechanism on a port.

Note - The Module ID and Port Number parameters under each Attack Type option do not return valid values. They return "noSuchName.", "No such instance" or NULL.

Note - The Attack Mirror Port parameter under each Attack Type option is already obsolete and should be ignored.

Note - The Attack Mirror Port Status parameter is not applicable to the SYN Flood and Smurf defenses and should be ignored.

Stacking Menu

From the Stacking menu, you can access slave switches and other Master switches in the enhanced stack.

Stacking Info

Displays Enhanced Stacking parameters, allows you to set the switch's enhanced stacking status and select a switch to manage in the enhanced stack.

Expansion Module Notes

- When adding/removing/changing an expansion module, Device Manager does not automatically refresh the device image in the main window to reflect the addition/removal/change. To view the updated device image, click on the Refresh option under the Agent menu.
- The Port Speed and Mode parameter of the 100Base-FX port on the AT-A45/SC, AT-A45/SC-SMI5 and AT-A45/MT expansion modules can only be set to '100Mbps full-duplex'.

- The AT-A46 expansion module port cannot be manually set to 1000Mbps. However, the current firmware version allows the Port Speed and Mode parameter for this port to be set to '1Gbps full-duplex' or '1Gbps half-duplex'
- The current firmware version allows the Port Speed and Mode parameter of the AT-A47 expansion module port to be set to '10Mbps full-duplex' or '100Mbps full-duplex' even if the GBIC installed is not capable of 10/100 Mbps connectivity.
- The Port Speed and Mode parameter of the AT-STACKM expansion module port should have a fixed value of 'auto sense'. However, the current firmware version allows it to be changed to '10Mbps full-duplex', '100Mbps full-duplex' or '1Gbps full-duplex'.

AT-8700XL Series

This section describes Device Manager menus and operations specific to the AT-8700XL Series of Advanced Layer 2 Switches.

Topics:

- Main Window
- Agent Menu
- Routing Menu
- Bridge Menu
- Port Menu

Main Window

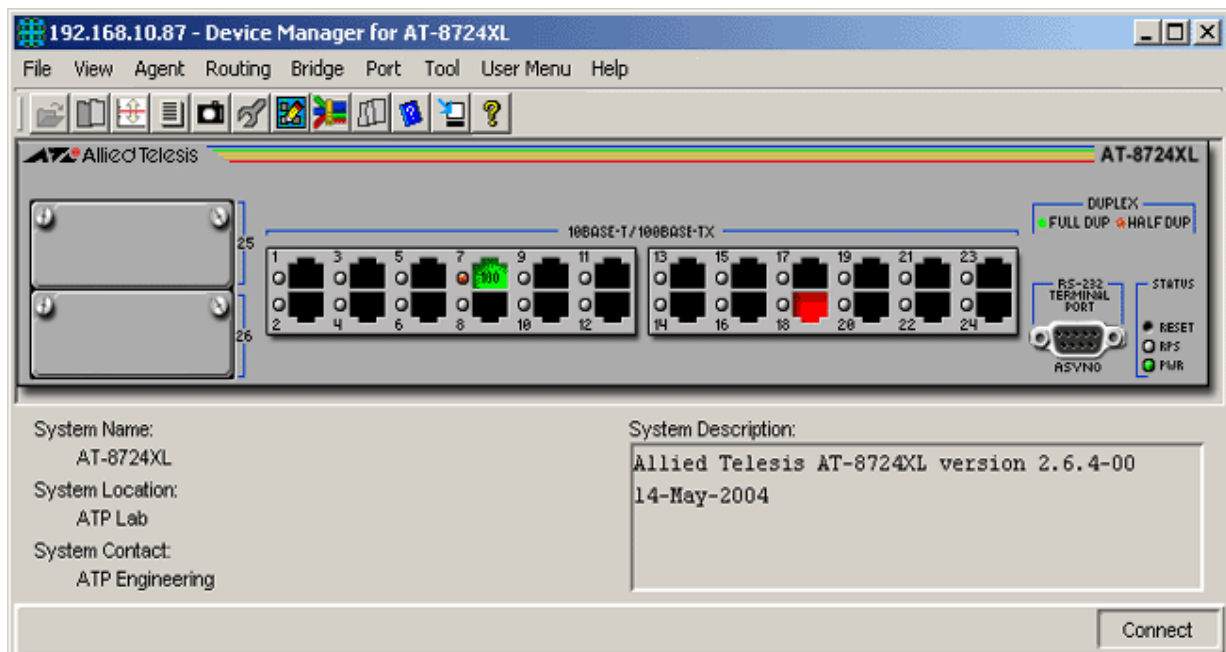

AT-8724XL

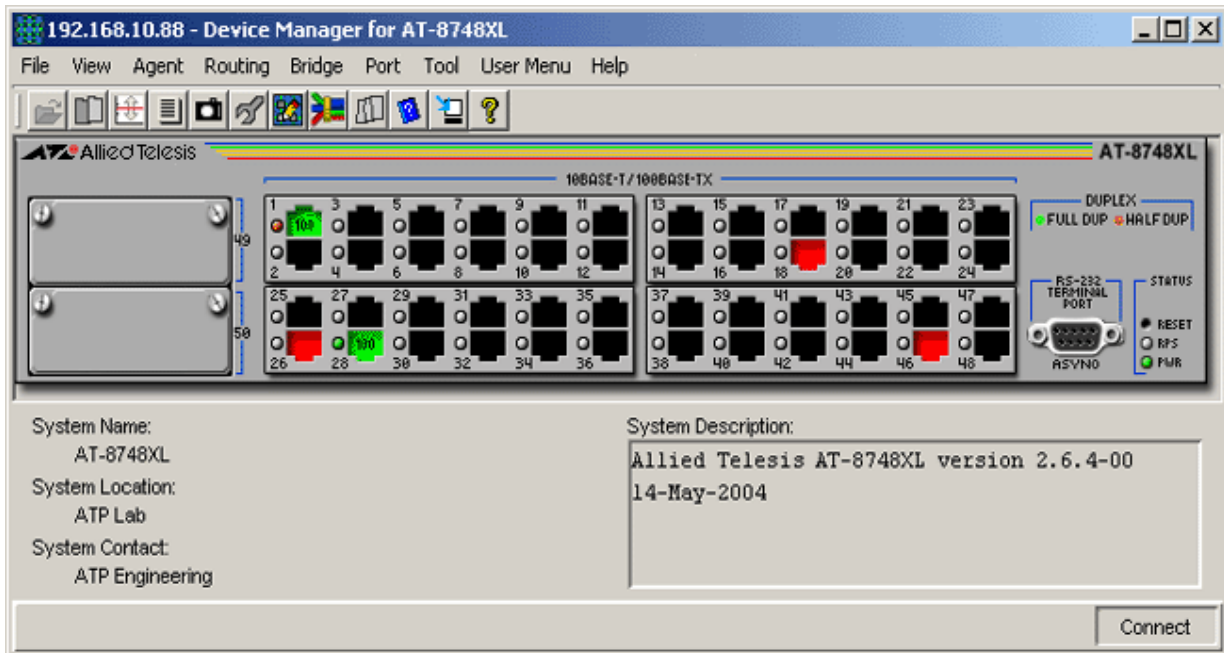

AT-8748XL

Device Manager LEDs for AT-8700XL Series (AC Models)

LED	State	Description
PWR	Green	The switch is receiving power from the main power supply.
	Red	Main power supply is either off or has failed.
RPS	Green	The switch is receiving power from the redundant power supply.
	Red	RPS has failed.
	Gray	RPS is not installed or RPS monitoring is disabled.
DUPLEX	Green	The port is operating at full duplex.
	Orange	The port is operating at half duplex.

Device Manager LEDs for AT-8700XL Series (DC Models)

LED	State	Description
PWR	Green	The switch is receiving power.
DUPLEX	Green	The port is operating at full duplex.
	Orange	The port is operating at half duplex.

Note - AT-8724XL and AT-8724XL-DC share the same device image.

Note - AT-8748XL and AT-8748XL-DC share the same device image.

Note - Please refer to Uplink Modules for the operations and behavior of the uplink modules installed on these devices.

Note - To turn RPS monitoring on or off on the switch, enter the command SET SYSTEM RPSMONITOR={ON|OFF} from the command line interface. To see whether RPS monitoring is on, use the command SHOW SYSTEM. To turn on RPS monitoring using SNMP, set the fanAndPsRpsMonitoringStatus variable to on.

Note - The current firmware version does not allow Device Manager to support the Reset button.

Note - The current firmware version does not allow Device Manager to support the RPS LED on the DC models.

Agent Menu

From the Agent menu, you can view and edit the system information for the switch, or log into the CLI using Telnet.

System Info

Displays basic system information, including system name, location, contact and description.

Power Supply Info

Displays information about the power supply, redundant power supply and power supply monitoring. (AC models only)

File List

Displays a list of the files in the switch's flash file system.

Config File Name

Displays the file name of the start-up configuration file.

Telnet

Starts a Telnet connection to the switch.

WEB Browser

Opens your web browser and connects to the switch's HTTP server.

Note - The web browser can only contact the device if the device has a valid resource file loaded and set, and the HTTP server and GUI on the device are enabled.

Routing Menu

From the Routing menu, you can view and edit information about the switch's IP routing functions.

ARP Table

Displays the mapping of IP addresses to MAC addresses (the ARP cache), on the switch.

Address Table

Displays the list of IP interfaces and their IP addresses on the switch.

Route Table

Displays the IP routing table on the switch.

IP Statistics

Displays statistics about IP routing, including the number of IP datagrams received.

ICMP Statistics

Displays statistics about ICMP, including the number of ICMP datagrams received.

Bridge Menu

From the Bridge menu, you can view and edit bridge information such as the forwarding database and the spanning tree status.

Forwarding Database

Standard View

Displays the Forwarding Database table as returned by the device.

Enhanced View

Displays the Forwarding Database table on a per port basis. User can select a port or group of ports to view its corresponding Forwarding Database entries.

Discard/Aging Time Info

Displays information about the number of address entries that were learned but discarded because either there was a lack of memory or the entry's aging timer expired.

Spanning Tree Info

Displays spanning tree parameters such as priority and cost.

Statistics

Displays statistics about frames received/transmitted on the switch port.

Port Menu

From the Port menu, you can view and edit MIB information about the port.

Utilization

Displays the port's utilization information.

Interface Info

Displays port statistics such as the number of frames received and transmitted on the port, bytes received and transmitted on the port, and port status.

Error Statistics

Displays error statistics.

Spanning Tree Info

Displays the port's spanning tree parameters.

Enable

Enables the port.

Disable

Disables the port.

AT-8700XL Series

Layer 3 Switches

AT-8600 Series

This section describes Device Manager menus and operations specific to the AT-8600 Series Layer 3 Switch.

Topics:

- Main Window
- Agent Menu
- Routing Menu
- Bridge Menu
- Port Menu
- Expansion Module Notes

Main Window

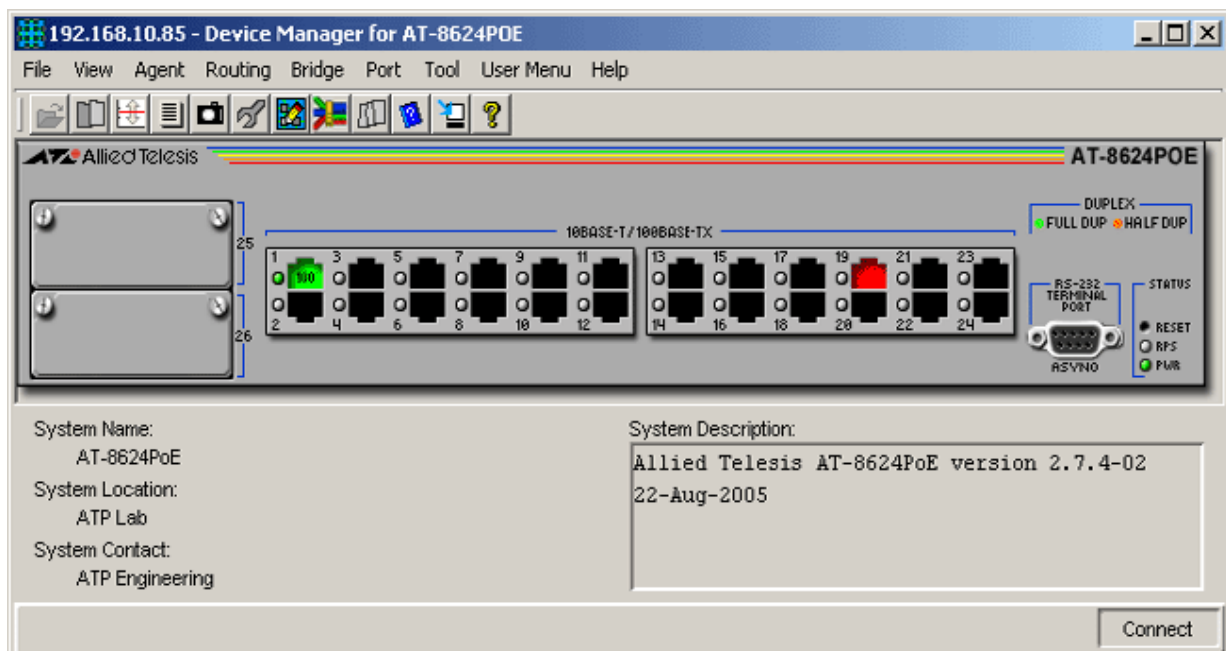

AT-8624POE

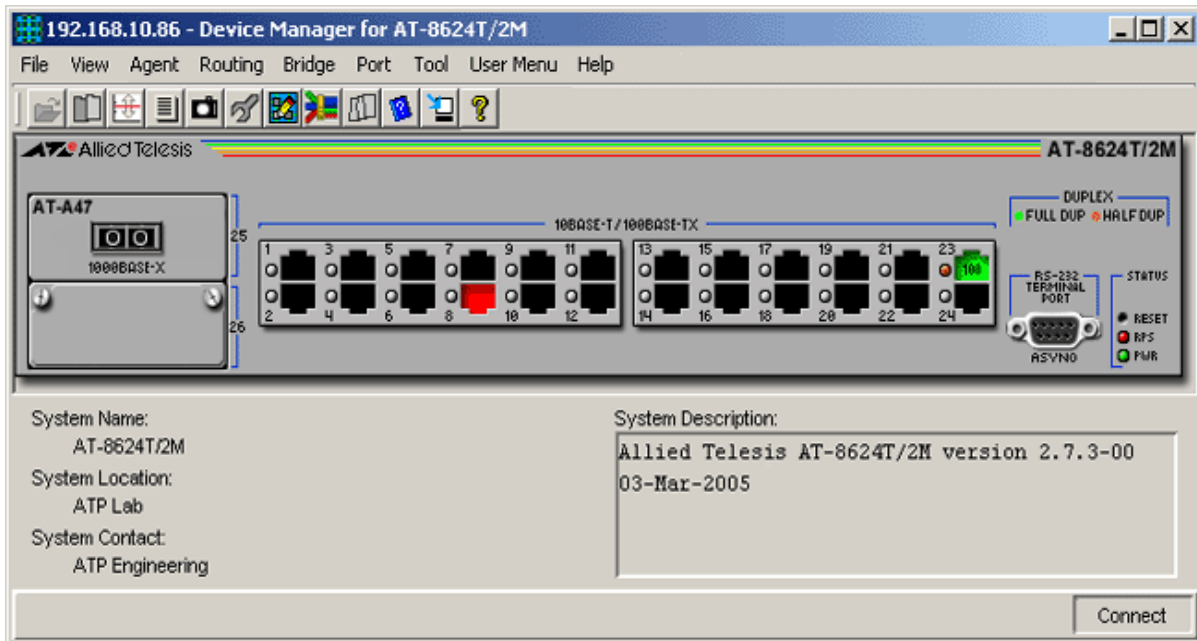

AT-8624T/2M

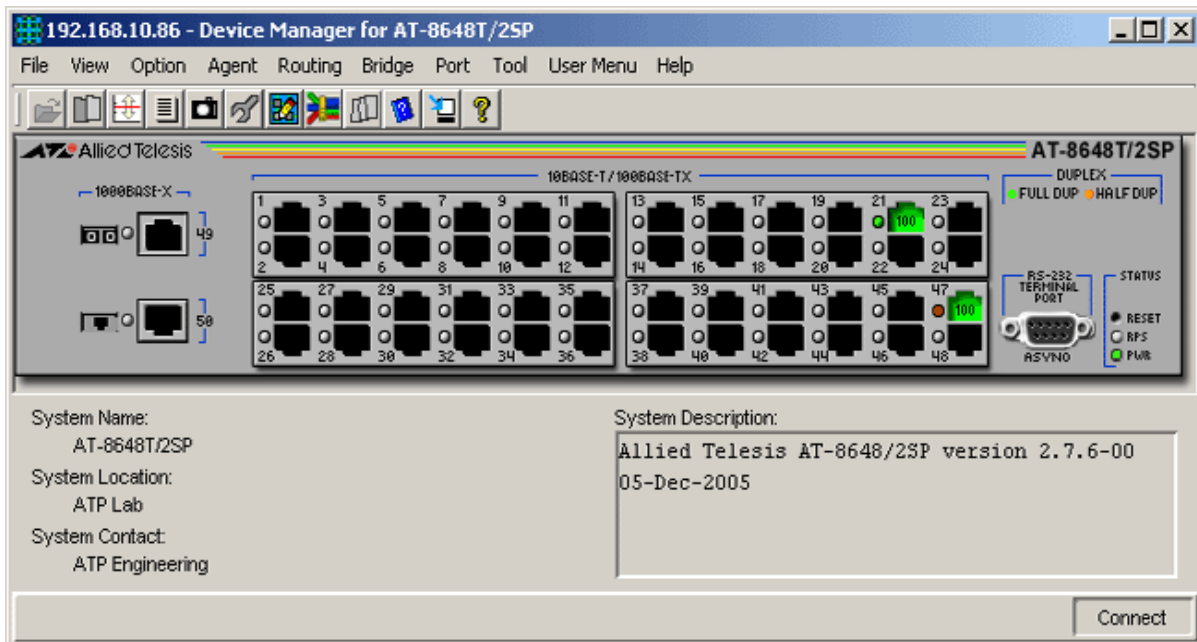

AT-8648T/2SP

Device Manager LEDs for AT-8600 Series

LED	State	Description
PWR	Green	The switch is receiving power from the main power supply.
	Red	Main power supply is either off or has failed.
RPS	Green	The switch is receiving power from the redundant power supply.

Device Manager LEDs for AT-8600 Series		
LED	State	Description
	Red	RPS has failed.
	Gray	RPS is not installed or RPS monitoring is disabled.
DUPLEX	Green	The port is operating at full duplex.
	Orange	The port is operating at half duplex.

Note - At device start-up, the current firmware version returns 'operational' status for all ports. As a result, RJ-45 SFP port image will appear on ports 49-50 even if there is no SFP module inserted.

Note - The current firmware version does not allow Device Manager to support the Reset button.

Agent Menu

From the Agent menu, you can view and edit the system information for the switch, or log into the CLI using Telnet.

System Info

Displays basic system information, including system name, location, contact and description.

Power Supply Info

Displays information about the power supply, redundant power supply and power supply monitoring.

File List

Displays a list of the files in the switch's file system.

Config File Name

Displays the file name of the start-up configuration file.

Telnet

Starts a Telnet connection to the switch.

WEB Browser

Opens your web browser and connects to the switch's HTTP server.

Note - The web browser can only contact the device if the device has a valid resource file loaded and set, and the HTTP server and GUI on the device are enabled.

Routing Menu

From the Routing menu, you can view and edit information about the switch's IP routing functions.

ARP Table

Displays the mapping of IP addresses to MAC addresses (the ARP cache), on the switch.

Address Table

Displays the list of IP interfaces and their IP addresses on the switch.

Route Table

Displays the IP routing table on the switch.

IP Statistics

Displays statistics about IP routing, including the number of IP datagrams received.

ICMP Statistics

Displays statistics about ICMP, including the number of ICMP datagrams received.

Bridge Menu

From the Bridge menu, you can view and edit bridge information such as the forwarding database and the spanning tree status.

Forwarding Database

Standard View

Displays the Forwarding Database table as returned by the device.

Enhanced View

Displays the Forwarding Database table on a per port basis. User can select a port or group of ports to view its corresponding Forwarding Database entries.

Discard/Aging Time Info

Displays information about the number of address entries that were learned but discarded because either there was a lack of memory or the entry's aging timer expired.

Spanning Tree Info

Displays spanning tree parameters such as priority and cost.

Statistics

Displays statistics about frames received/transmitted on the switch port.

Port Menu

From the Port menu, you can view and edit MIB information about the port.

Utilization

Displays the port's utilization information.

Interface Info

Displays port statistics such as the number of frames received and transmitted on the port, bytes received and transmitted on the port, and port status.

Error Statistics

Displays error statistics.

Spanning Tree Info

Displays the port's spanning tree parameters.

MAU Info

Displays interface-related MAU information for the port.

MAU Negotiation Info

Displays the MAU's auto-negotiation settings and its status.

Enable

Enables the port.

Disable

Disables the port.

Expansion Module Notes

- A GBIC image is always visible on the GBIC slot of the AT-A47 expansion module even if there is no GBIC physically inserted.

AT-8800 Series

This section describes Device Manager menus and operations specific to the AT-8800 Series of Intelligent Workgroup Switches.

Topics:

- Main Window
- Agent Menu
- Routing Menu
- Bridge Menu
- Port Menu

Main Window

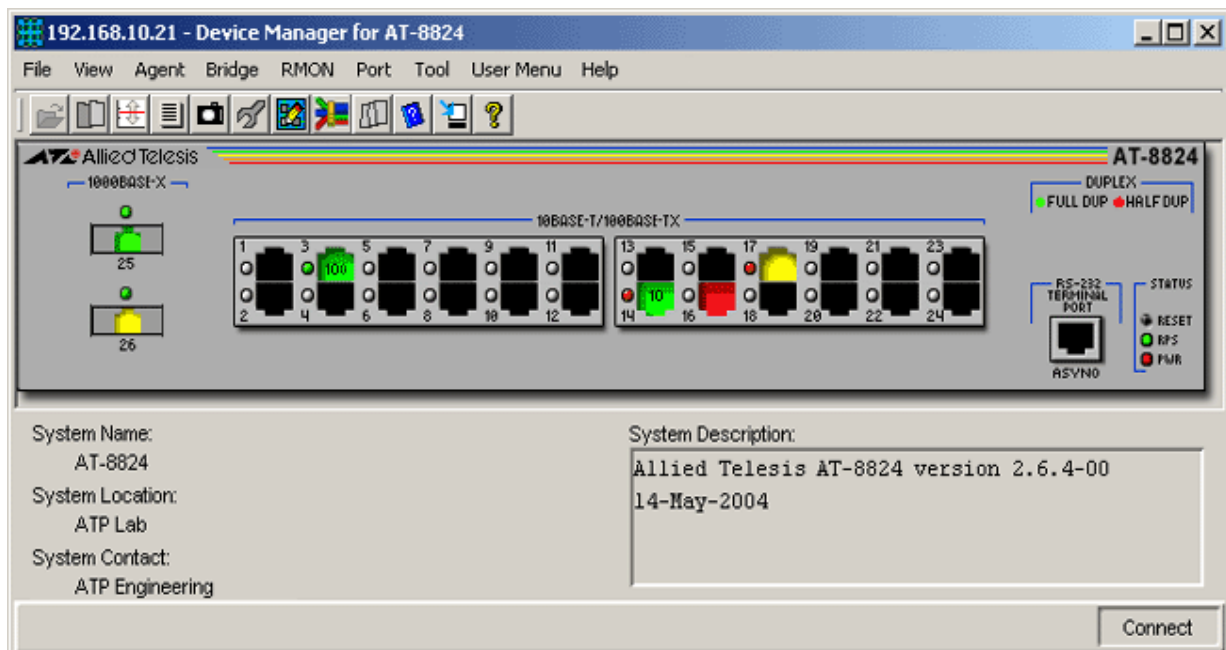

AT-8824

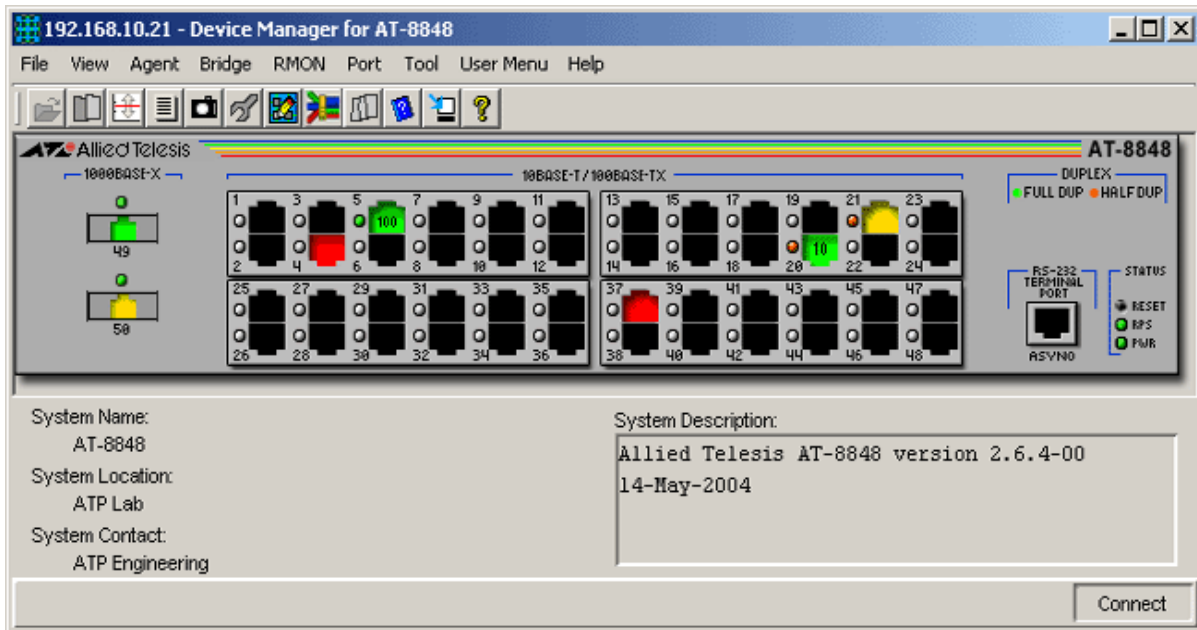

AT-8848

Device Manager LEDs for AT-8800 Series		
LED	State	Description
PWR	Green	The switch is receiving power from the main power supply.
	Red	Main power supply is either off or has failed.
RPS	Green	The switch is receiving power from the redundant power supply.
	Red	RPS has failed.
	Gray	RPS is not installed or RPS monitoring is disabled.
DUPLEX	Green	The port is operating at full duplex.
	Orange	The port is operating at half duplex.
	Grey	There is no link over the port.

Note - To turn RPS monitoring on or off on the switch, enter the command SET SYSTEM RPSMONITOR={ON|OFF} from the command line interface. To see whether RPS monitoring is on, use the command SHOW SYSTEM. To turn on RPS monitoring using SNMP, set the fanAndPsRpsMonitoringStatus variable to on.

Agent Menu

From the Agent menu, you can view and edit the system information for the switch, or log into the CLI using Telnet.

System Info

Displays basic system information, including system name, location, contact and description.

Firmware Info

Displays a list of software releases installed on the switch.

Power Supply Info

Displays information about the power supply, redundant power supply and power supply monitoring.

File List

Displays a list of the files in the switch's file system.

Config File Name

Displays the file name of the start-up configuration file.

Chassis Temperature Info

Displays the actual temperature of the switch and the temperature status.

Reset Cold

Resets the hardware and executes the default configuration file.

Reset Warm

Performs a warm start of the software modules and executes the default configuration file.

Telnet

Starts a Telnet connection to the switch.

WEB Browser

Opens your web browser and connects to the switch's HTTP server.

Note - The web browser can only contact the device if the device has a valid resource file loaded and set, and the HTTP server and GUI on the device are enabled.

Routing Menu

From the Routing menu, you can view and edit information about the switch's IP routing functions.

ARP Table

Displays the ARP cache on the switch.

Address Table

Displays the list of IP interfaces on the switch.

Route Table

Displays the IP routing table on the switch.

IP Statistics

Displays statistics about IP, such as the number of IP datagrams received.

ICMP Statistics

Displays statistics about ICMP, such as the number of ICMP datagrams received.

Bridge Menu

From the Bridge menu, you can view and edit bridge information such as the forwarding database and the spanning tree status.

Forwarding Database

Standard View

Displays the Forwarding Database table as returned by the device.

Enhanced View

Displays the Forwarding Database table on a per port basis. User can select a port or group of ports to view its corresponding Forwarding Database entries.

Discard/Aging Time Info

Displays information about the number of address entries that were learned but discarded for reasons such as lack of memory or the entry's aging timer.

Spanning Tree Info

Displays spanning tree parameters such as priority and cost.

Statistics

Displays statistics about frames received/transmitted on the switch port.

Port Menu

From the Port menu, you can view and edit MIB information about the port.

Utilization

Displays the port's utilization information.

Interface Info

Displays port statistics such as the number of frames received and transmitted on the port, bytes received and transmitted on the port, and port status.

Error Statistics

Displays error statistics.

Spanning Tree Info

Displays the port's spanning tree parameters.

MAU Info

Displays interface-related MAU information for the port.

MAU Negotiation Info

Displays the MAU's auto-negotiation settings and its status.

Enable

Enables the port.

Disable

Disables the port.

AT-8948

This section describes Device Manager menus and operations specific to the AT-8948 Enhanced Layer 3+ Switch.

Topics:

- Main Window
- Agent Menu
- Routing Menu
- Bridge Menu
- LLDP Menu
- Availability Menu
- Security Menu
- RMON Menu
- Port Menu

Main Window

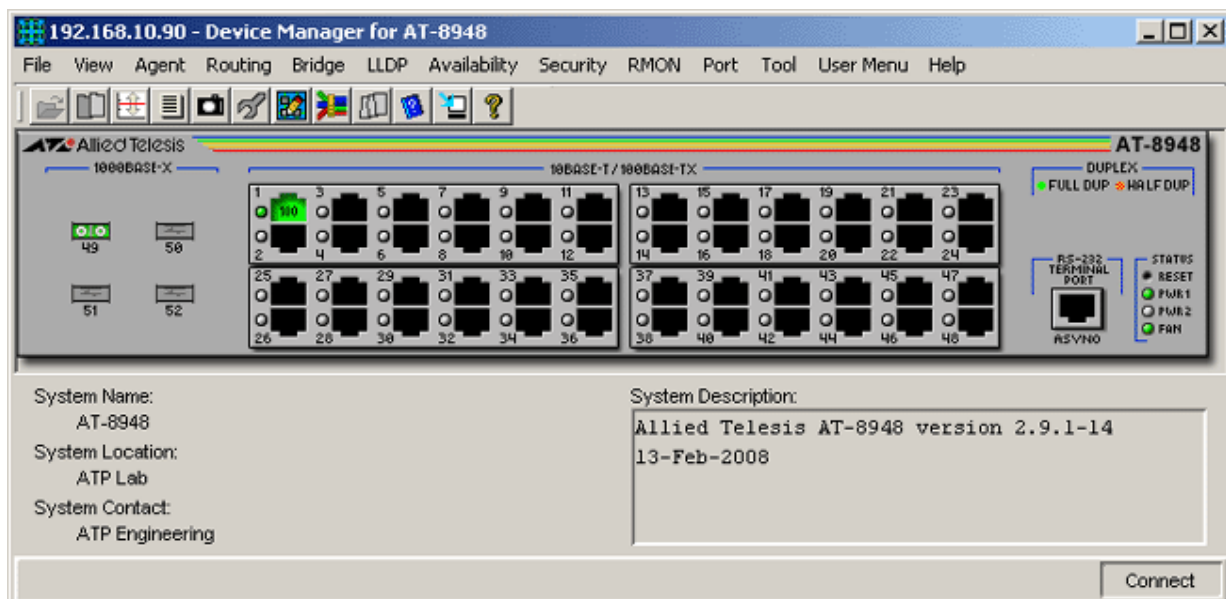

AT-8948

Device Manager LEDs for the AT-8948		
LED	State	Description
PWR 1 and PWR 2	Green	There is a power supply unit (PSU) in the PSU bay.
	Gray	There is no power supply unit (PSU) in the PSU bay.
FAN	Green	There is a functioning Fan Only Module (FOM) in the PSU bay.
	Gray	There is no functioning Fan Only Module (FOM) in the PSU bay.
DUPLEX	Green	The port is operating at full duplex.
	Orange	The port is operating at half duplex.

Note - The current firmware version does not allow Device Manager to display the correct image for SFP module 'AT-SPFXBD-LC-13'. As a result, the SFP image that will be displayed is the generic SFP Fiber image.

Note - When a single PSU is installed, it is advised to install it in the device's PSU Bay 2 in order for the Device Manager to display correct information on the Fan and Power Supply modules.

Agent Menu

From the Agent menu, you can view and edit the system information for the switch, or log into the CLI using Telnet.

System Info

Standard

Displays basic system information, including system name, location, contact and description.

Enterprise

CPU Utilization

Displays information about the CPU utilization over different periods of time.

Power Supply Info

Displays information about the power supply, redundant power supply and power supply monitoring.

Fan and Power Supply

Displays information about type and status of the Fan and PSU.

Temperature

Displays information about the temperature monitored by the temperature sensors in the device.

Note - The current firmware version does not allow the Temperature Threshold parameter to be configured.

Host Resources

General System Info

Displays general information about the host resources.

Note - Device Manager does not handle objects of type OCTET STRING correctly. As a result, the Time and Date parameter will display a sequence of bytes in hexadecimal format instead of the actual date and time of day.

Note - The Time and Date and Initial Load Parameter parameters are implemented as 'read-only'.

Logical Storage Areas

Displays resource information about the storage devices.

Note - The Storage Size parameter is implemented as 'read-only'.

Devices

Displays resource information about the devices installed in the host.

Hardware Info

Total Boards

Displays the number of boards that are currently installed.

Board Info

Displays basic information on the boards that are currently installed.

Slot Info

Displays information on the Power Supply Bay slots.

Physical Interfaces

Displays information about the interfaces found in the device.

Firmware Info

Install Configurations

Displays information about the Software release currently loaded in the device.

Note - The current firmware version returns a 'noSuchName' value for the Release File Exists? and Patch File Exists? parameters.

Install History

Displays information about the install history.

Configuration File

Displays the Configuration file name.

Note - The current firmware version accepts inputs from 5 to 32 characters for the Startup Config and Save Running Config parameters.

Release Licenses

Displays a list of software releases installed on the switch.

Note - The current firmware version does not allow any of the parameters under this table to be configured.

File System

Total Files

Displays the total number of files stored in the device.

File List

Displays a list of the files in the switch's file system.

Loader

Load Status

Displays the status of the device loader.

Load Parameters

Displays information about the files to be loaded.

DHCP Ranges

Displays information about the DHCP module.

Reset Cold

Initiates a cold restart on the switch.

Reset Warm

Initiates a warm restart on the switch.

Reset Info

Displays information about the restart.

Telnet

Starts a Telnet connection to the switch.

WEB Browser

Opens your web browser and connects to the switch's HTTP server.

Note - The web browser can only contact the device if the device has a valid resource file loaded and set, and the HTTP server and GUI on the device are enabled.

Routing Menu

From the Routing menu, you can view and edit information about the switch's IP routing functions.

IP

ARP Table

Displays the ARP cache on the switch.

Note - The Physical Address and Mapping Type parameters are implemented as 'read-only'.

Address Table

Displays the list of IP interfaces on the switch.

Route Number

Displays the IP routing number on the switch.

Route Table

Displays the IP routing table on the switch.

Note - The current firmware version returns the value 'NULL' for the Routing Protocol MIB parameter.

Note - The following parameters are implemented as 'read-only':

- Destination Port Number
- Routing Type
- Next Hop AS Number
- Destination Metric 1
- Destination Metric 2
- Destination Metric 3
- Destination Metric 4
- Destination Metric 5
- Row Status

IP Statistics

Displays statistics about IP, such as the number of IP datagrams received.

Note - The Default TTL parameter is implemented as 'read-only'.

UDP

Listener Info

Displays UDP listener information.

UDP Statistics

Displays UDP statistics.

TCP

Connection Info

Displays TCP connection-specific information.

Note - The Connection Status parameter is implemented as 'read-only'.

TCP Statistics

Displays TCP statistics.

ICMP Statistics

Displays ICMP statistics.

BGP

General Info

Displays information about the BGP module.

Peer Info

Displays BGP Peer information.

Note - The current firmware version does not allow the following parameters to be configured:

- Connect Retry Interval
- Configured Hold Time
- Configured Keep Alive
- Min AS Origination Interval
- Min Route Advertisement Interval

Path Attributes

Displays the BGP path attributes.

Bridge Menu

From the Bridge menu, you can view and edit bridge information such as the forwarding database and the spanning tree status.

Forwarding Database

Standard View

Displays the Forwarding Database table as returned by the device.

Enhanced View

Displays the Forwarding Database table on a per port basis. User can select a port or group of ports to view its corresponding Forwarding Database entries.

Discard/Aging Time Info

Displays information about the number of address entries that were learned but discarded for reasons such as lack of memory or the entry's aging timer.

Spanning Tree Info

Displays spanning tree parameters such as priority and cost.

Note - Valid MIB Set values for the Port Path Cost parameter is in the range [1-65535] inclusive.

Statistics

Displays statistics about frames received/transmitted on the switch port.

Basic Bridge Info

Displays basic bridge information.

Bridge Port Info

Displays bridge port information.

Note - The current firmware version returns the value 'NULL' for the Circuit parameter.

LLDP Menu

From the LLDP menu, you can view and edit LLDP information such as the LLDP Port Configuration and Local System Data.

LLDP Configuration

General Config

Displays basic LLDP configuration.

Port Config

Displays LLDP configuration for each port.

Note - Device Manager does not handle objects of type BITS correctly. As a result, the TLVs Tx Enable parameter will not be configurable and will display an 8-bit binary string instead of the actual TLV types allowed. However, the TLV types allowed can still be determined by looking at the bits that are on from left to right:

- Bit 0 - Port Description
- Bit 1 - System Name
- Bit 2 - System Description
- Bit 3 - System Capabilities

LLDP Statistics

Remote Tables

Displays statistics for the LLDP remote tables.

Port Tx

Displays statistics for LLDP frames transmitted.

Port Rx

Displays statistics for received LLDP frames.

Local System Data

General Info

Displays information about the local LLDP system.

Port Info

Displays information on the LLDP of local ports.

Management Addresses

Displays management addresses of the local LLDP system.

Note - Device Manager does not handle objects of type OCTET STRING correctly. As a result, the Port Tx Enable parameter will display a sequence of bytes in hexadecimal format instead of the actual input value.

Note - The current firmware version returns the value 'NULL' for the OID parameter.

Availability Menu

From the Availability menu you can view and edit Server Load Balancing and Ping Polling information.

Server Load Balancing

General Info

Displays basic server load balancing information.

Resources

Displays server load balancing resources information.

Resource Pools

Displays server load balancing resource pools information.

Virtual Balancers

Displays virtual balancers information.

Affinity Tables

Displays load balancer affinities information.

Open TCP Connections

Displays open TCP connections information.

Ping Polling

Ping Status

Displays the status of the Ping polling.

Note - The current firmware version only allows the Ping Status parameter to be configured if Protocol parameter under Ping Parameters is set to OSI.

Ping Parameters

Displays basic information of the Ping module.

Note - Valid MIB Set values for the Timeout parameter should range from 1 to 60. However, the current firmware version allows the user to enter values in the range [-9223372036854775808 to -1, 1 to 9223372036854775807] inclusive. But attempting to enter values greater than 65535 will cause the new value to be converted to its equivalent wrap-around value; i.e., 65536 will become 0, 65537 will become 1, and so on.

Note - Valid MIB Set values for the Time Interval parameter should range from 0 to 604800. However, the current firmware version allows the user to enter values in the range [-9223372036854775808 to 9223372036854775807] inclusive. But attempting to enter values greater than 999999999 will cause the new value to be converted to its equivalent wrap-around value; i.e., 9999999990 will become 1410065398, 9999999991 will become 1410065399, and so on.

Note - Valid MIB Set values for the Number of Packets parameter should range from 1 to 4294967295. However, the current firmware version does not allow Device Manager to display the correct value greater than 2147483647. Attempting to enter values greater than 2147483647 will cause the new value to be converted to its equivalent wrap-around value; i.e. 2147483648 will become -2147483648, 2147483649 will become -2147483647, and so on.

Note - The current firmware version only allows the Address parameter to be configured if the Protocol parameter is set to OSI.

Note - Valid MIB Set values for the Data Pattern parameter should range from 1 to 4294967295. However, the current firmware version does not allow Device Manager to display the correct value greater than 2147483647. Attempting to enter values greater than 2147483647 will cause the new value to be converted to the following values:

- 4286578688 - 4294934527: 8388608 - 16744447
- 4294934528 - 4294967167: 32768 - 65407
- 4294967168 - 4294967295: 128 - 255

Note - Device Manager does not handle objects of type OCTET STRING correctly. As a result, the Address parameter will not be configurable and will display a sequence of bytes in hexadecimal format instead of the actual destination of ping packets.

Ping Statistics

Displays statistics of the Ping polling.

Security Menu

From the Security menu, you can view and edit port access entity information such as the PAE port information and the Supplicant PAE information.

Port-based Authentication

Authentication Status

Displays the status of the port-based authentication.

PAE Port Info

Standard

Displays standard PAE port information.

Note - Device Manager does not handle objects of type BITS correctly. As a result, the Capabilities parameter will display an 8-bit binary string instead of the actual PAE functionality supported. However, the PAE functionality supported can still be determined by looking at the bits that are on from right to left:

- Bit 0 - Authenticator
- Bit 1 - Supplicant

Enterprise

Displays enterprise PAE port information.

Authenticator PAE Info

Standard

Displays standard authenticator PAE information.

Note - The Administrative Controlled Directions and Key Transmission Status parameters are implemented as 'read-only'.

Enterprise

Displays enterprise authenticator PAE information.

Authenticator PAE Statistics

Standard

Displays standard statistics for the PAE Authenticator.

Enterprise

Displays enterprise statistics for the PAE Authenticator.

Supplicant PAE Info

Displays supplicant PAE information.

Supplicant PAE Statistics

Displays the statistics for the PAE supplicant.

MAC-based Authentication

PAE Port Info

Displays PAE port information.

Note - The Initialize parameter is implemented as 'read-only'.

Authenticator PAE Info

Displays authenticator PAE information.

Firewall Session Statistics

Displays the statistics for the firewall sessions.

RMON Menu

From the RMON menu you can view and edit the RMON MIB.

Statistics

Displays traffic statistics in the network segment attached to each port.

History Control Table

Displays the RMON History table.

Alarm Table

Displays the RMON Alarm table.

Event Table

Displays the RMON Event table.

Event Log

Displays the RMON Event log.

Port Menu

From the Port menu, you can view and edit MIB information about selected ports.

Utilization

Displays the port's utilization information.

Interface Info

Displays port statistics such as the number of frames received and transmitted on the port, bytes received and transmitted on the port, and port status. This table also displays high-capacity port statistics including received and transmitted unicast/multicast/broadcast packets on the port, link up/down trap and port speed.

Note - The current firmware version returns a 'noSuchName' value for the Port Alias and Counter Discontinuity Time parameters.

Detail Info

Duplex Mode

Displays the duplex mode of the ports.

Bandwith Limits

Displays bandwidth limits of the switch ports.

Error Statistics

Displays error statistics.

Note - The following parameters are not applicable to the AT-8948 and should be ignored:

- Ethernet Chip Set
- Symbol Errors
- Duplex Status

Spanning Tree Info

Displays the port's spanning tree parameters.

MAU Info

Displays interface-related MAU information for the port.

Note - The MAU Type List Bits and HC False Carriers parameters are not applicable to the AT-8948.

Note - The MAU Status and Default MAU Type parameters are implemented as 'read-only'.

MAU Negotiation Info

Displays the MAU's auto-negotiation settings and its status.

Note - The following parameters are not applicable to the AT-8948 and should be ignored:

- Capability Bits
- Advertised Bits
- Received Bits
- Remote Fault Advertised
- Remote Fault Received

Note - The Administration Status, Advertised Negotiation Capability and Restart parameters are implemented as 'read-only'.

Port Trunking

Aggregator Port List

Displays Link Aggregation Control information for every Aggregation Port associated with this device.

Note - The following parameters are implemented as 'read-only':

- Actor Operational Key
- Partner Administrative System Priority
- Partner Administrative System ID
- Partner Administrative Key
- Partner Administrative Port
- Partner Administrative Port Priority
- Actor Administrative Status
- Partner Administrative Status

LACP Statistics

Displays Link Aggregation information for every port that is associated with this device.

LACP Debug

Displays Link Aggregation debug information for every port that is associated with this device.

Enable

Enables the port.

Disable

Disables the port.

AT-8948

AT-x900-48 Series

This section describes Device Manager menus and operations specific to the AT-x900-48 Series Enhanced Layer 3+ Switch.

Topics:

- Main Window
- Agent Menu
- Routing Menu
- Bridge Menu
- LLDP Menu
- Availability Menu
- Security Menu
- RMON Menu
- Port Menu

Main Window

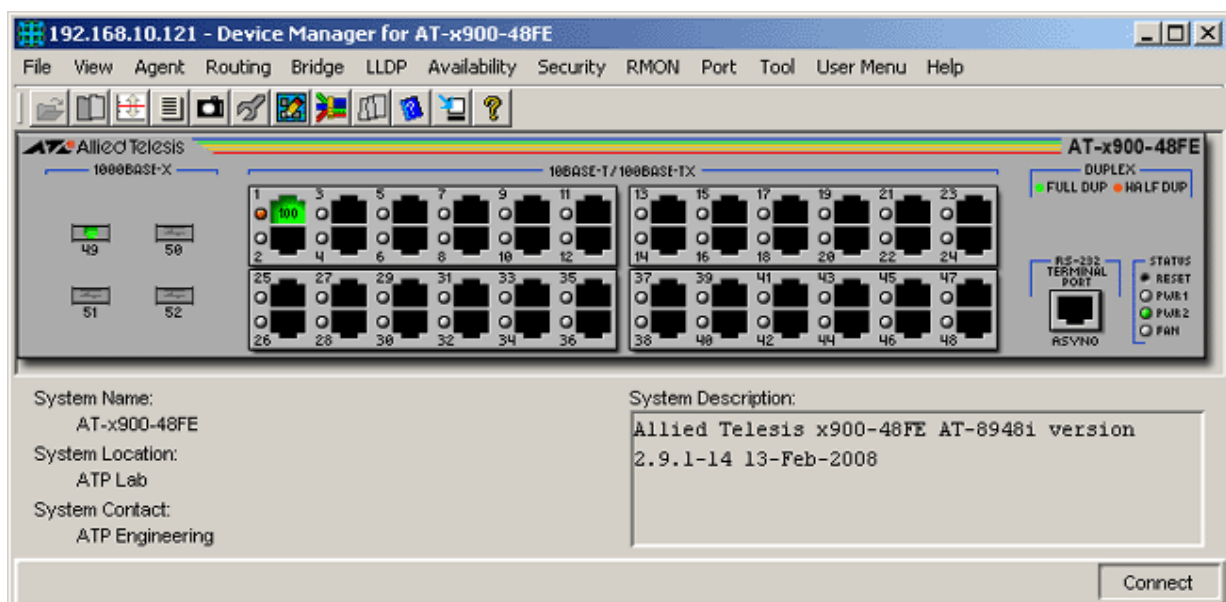

AT-x900-48FE

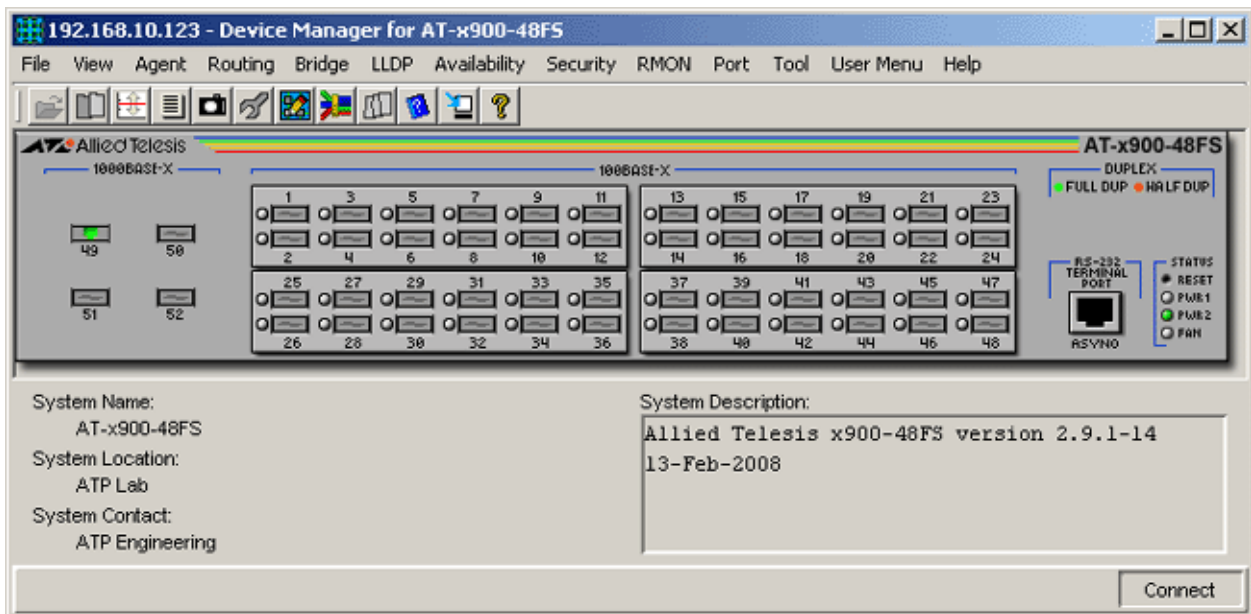

AT-x900-48FS

Device Manager LEDs for the AT-x900-48 Series

LED	State	Description
PWR 1 and PWR 2	Green	There is a power supply unit (PSU) in the PSU bay.
	Gray	There is no power supply unit (PSU) in the PSU bay.
FAN	Green	There is a functioning Fan Only Module (FOM) in the PSU bay.
	Gray	There is no functioning Fan Only Module (FOM) in the PSU bay.
DUPLEX	Green	The port is operating at full duplex.
	Orange	The port is operating at half duplex.

Note - The current firmware version does not allow Device Manager to display the correct image for SFP module 'AT-SPFXBD-LC-13'. As a result, the SFP image that will be displayed is the generic SFP Fiber image.

Note - When a single PSU is installed, it is advised to install it in the device's PSU Bay 2 in order for the Device Manager to display correct information on the Fan and Power Supply modules.

Agent Menu

From the Agent menu, you can view and edit the system information for the switch, or log into the CLI using Telnet.

System Info

Standard

Displays basic system information, including system name, location, contact and description.

Enterprise

CPU Utilization

Displays information about the CPU utilization over different periods of time.

Power Supply Info

Displays information about the power supply, redundant power supply and power supply monitoring.

Fan and Power Supply

Displays information about type and status of the Fan and PSU.

Temperature

Displays information about the temperature monitored by the temperature sensors in the device.

Note - The current firmware version does not allow the Temperature Threshold parameter to be configured.

Host Resources

General System Info

Displays general information about the host resources.

Note - Device Manager does not handle objects of type OCTET STRING correctly. As a result, the Time and Date parameter will display a sequence of bytes in hexadecimal format instead of the actual date and time of day.

Note - The Time and Date and Initial Load Parameter parameters are implemented as 'read-only'.

Logical Storage Areas

Displays resource information about the storage devices.

Note - The Storage Size parameter is implemented as 'read-only'.

Devices

Displays resource information about the devices installed in the host.

Hardware Info

Total Boards

Displays the number of boards that are currently installed.

Board Info

Displays basic information on the boards that are currently installed.

Slot Info

Displays information on the Power Supply Bay slots.

Physical Interfaces

Displays information about the interfaces found in the device.

Firmware Info

Install Configurations

Displays information about the Software release currently loaded in the device.

Note - The current firmware version returns a 'noSuchName' value for the Release File Exists? and Patch File Exists? parameters.

Install History

Displays information about the install history.

Configuration File

Displays the Configuration file name.

Note - The current firmware version accepts inputs from 5 to 32 characters for the Startup Config and Save Running Config parameters.

Release Licenses

Displays a list of software releases installed on the switch.

Note - The current firmware version does not allow any of the parameters under this table to be configured.

File System

Total Files

Displays the total number of files stored in the device.

File List

Displays a list of the files in the switch's file system.

Loader

Load Status

Displays the status of the device loader.

Load Parameters

Displays information about the files to be loaded.

DHCP Ranges

Displays information about the DHCP module.

Reset Cold

Initiates a cold restart on the switch.

Reset Warm

Initiates a warm restart on the switch.

Reset Info

Displays information about the restart.

Telnet

Starts a Telnet connection to the switch.

WEB Browser

Opens your web browser and connects to the switch's HTTP server.

Note - The web browser can only contact the device if the device has a valid resource file loaded and set, and the HTTP server and GUI on the device are enabled.

Routing Menu

From the Routing menu, you can view and edit information about the switch's IP routing functions.

IP

ARP Table

Displays the ARP cache on the switch.

Note - The Physical Address and Mapping Type parameters are implemented as 'read-only'.

Address Table

Displays the list of IP interfaces on the switch.

Route Number

Displays the IP routing number on the switch.

Route Table

Displays the IP routing table on the switch.

Note - The current firmware version returns the value 'NULL' for the Routing Protocol MIB parameter.

Note - The following parameters are implemented as 'read-only':

- Destination Port Number
- Routing Type
- Next Hop AS Number
- Destination Metric 1
- Destination Metric 2
- Destination Metric 3
- Destination Metric 4
- Destination Metric 5
- Row Status

IP Statistics

Displays statistics about IP, such as the number of IP datagrams received.

Note - The Default TTL parameter is implemented as 'read-only'.

UDP

Listener Info

Displays UDP listener information.

UDP Statistics

Displays UDP statistics.

TCP

Connection Info

Displays TCP connection-specific information.

Note - The Connection Status parameter is implemented as 'read-only'.

TCP Statistics

Displays TCP statistics.

ICMP Statistics

Displays ICMP statistics.

BGP

General Info

Displays information about the BGP module.

Peer Info

Displays BGP Peer information.

Note - The current firmware version does not allow the following parameters to be configured:

- Connect Retry Interval
- Configured Hold Time
- Configured Keep Alive
- Min AS Origination Interval
- Min Route Advertisement Interval

Path Attributes

Displays the BGP path attribute

Bridge Menu

From the Bridge menu, you can view and edit bridge information such as the forwarding database and the spanning tree status.

Forwarding Database

Standard View

Displays the Forwarding Database table as returned by the device.

Enhanced View

Displays the Forwarding Database table on a per port basis. User can select a port or group of ports to view its corresponding Forwarding Database entries.

Discard/Aging Time Info

Displays information about the number of address entries that were learned but discarded for reasons such as lack of memory or the entry's aging timer.

Spanning Tree Info

Displays spanning tree parameters such as priority and cost.

Note - Valid MIB Set values for the Port Path Cost parameter is in the range [1-65535] inclusive.

Statistics

Displays statistics about frames received/transmitted on the switch port.

Basic Bridge Info

Displays basic bridge information.

Bridge Port Info

Displays bridge port information.

Note - The current firmware version returns the value 'NULL' for the Circuit parameter.

LLDP Menu

From the LLDP menu, you can view and edit LLDP information such as the LLDP Port Configuration and Local System Data.

LLDP Configuration

General Config

Displays basic LLDP configuration.

Port Config

Displays LLDP configuration for each port.

Note - Device Manager does not handle objects of type BITS correctly. As a result, the TLVs Tx Enable parameter will not be configurable and will display an 8-bit binary string instead of the actual TLV types allowed. However, the TLV types allowed can still be determined by looking at the bits that are on from left to right:

- Bit 0 - Port Description
- Bit 1 - System Name
- Bit 2 - System Description
- Bit 3 - System Capabilities

LLDP Statistics

Remote Tables

Displays statistics for the LLDP remote tables.

Port Tx

Displays statistics for LLDP frames transmitted.

Port Rx

Displays statistics for received LLDP frames.

Local System Data

General Info

Displays information about the local LLDP system.

Port Info

Displays information on the LLDP of local ports.

Management Addresses

Displays management addresses of the local LLDP system.

Note - Device Manager does not handle objects of type OCTET STRING correctly. As a result, the Port Tx Enable parameter will display a sequence of bytes in hexadecimal format instead of the actual input value.

Note - The current firmware version returns the value 'NULL' for the OID parameter.

Availability Menu

From the Availability menu you can view and edit Server Load Balancing and Ping Polling information.

Server Load Balancing

General Info

Displays basic server load balancing information.

Resources

Displays server load balancing resources information.

Resource Pools

Displays server load balancing resource pools information.

Virtual Balancers

Displays virtual balancers information.

Affinity Tables

Displays load balancer affinities information.

Open TCP Connections

Displays open TCP connections information.

Ping Polling

Ping Status

Displays the status of the Ping polling.

Note - The current firmware version only allows the Ping Status parameter to be configured if Protocol parameter under Ping Parameters is set to OSI.

Ping Parameters

Displays basic information of the Ping module.

Note - Valid MIB Set values for the Timeout parameter should range from 1 to 60. However, the current firmware version allows the user to enter values in the range [-9223372036854775808 to -1, 1 to 9223372036854775807] inclusive. But attempting to enter values greater than 65535 will cause the new value to be converted to its equivalent wrap-around value; i.e., 65536 will become 0, 65537 will become 1, and so on.

Note - Valid MIB Set values for the Time Interval parameter should range from 0 to 604800. However, the current firmware version allows the user to enter values in the range [-9223372036854775808 to 9223372036854775807] inclusive. But attempting to enter values greater than 999999999 will cause the new value to be converted to its equivalent wrap-around value; i.e., 9999999990 will become 1410065398, 9999999991 will become 1410065399, and so on.

Note - Valid MIB Set values for the Number of Packets parameter should range from 1 to 4294967295. However, the current firmware version does not allow Device Manager to display the correct value greater than 2147483647. Attempting to enter values greater than 2147483647 will cause the new value to be converted to its equivalent wrap-around value; i.e. 2147483648 will become -2147483648, 2147483649 will become -2147483647, and so on.

Note - The current firmware version only allows the Address parameter to be configured if the Protocol parameter is set to OSI.

Note - Valid MIB Set values for the Data Pattern parameter should range from 1 to 4294967295. However, the current firmware version does not allow Device Manager to display the correct value greater than 2147483647. Attempting to enter values greater than 2147483647 will cause the new value to be converted to the following values:

- 4286578688 - 4294934527: 8388608 - 16744447
- 4294934528 - 4294967167: 32768 - 65407
- 4294967168 - 4294967295: 128 - 255

Note - Device Manager does not handle objects of type OCTET STRING correctly. As a result, the Address parameter will not be configurable and will display a sequence of bytes in hexadecimal format instead of the actual destination of ping packets.

Ping Statistics

Displays statistics of the Ping polling.

Security Menu

From the Security menu, you can view and edit port access entity information such as the PAE port information and the Supplicant PAE information.

Port-based Authentication

Authentication Status

Displays the status of the port-based authentication.

PAE Port Info

Standard

Displays standard PAE port information.

Note - Device Manager does not handle objects of type BITS correctly. As a result, the Capabilities parameter will display an 8-bit binary string instead of the actual PAE functionality supported. However, the PAE functionality supported can still be determined by looking at the bits that are on from right to left:

- Bit 0 - Authenticator
- Bit 1 - Supplicant

Enterprise

Displays enterprise PAE port information.

Authenticator PAE Info

Standard

Displays standard authenticator PAE information.

Note - The Administrative Controlled Directions and Key Transmission Status parameters are implemented as 'read-only'.

Enterprise

Displays enterprise authenticator PAE information.

Authenticator PAE Statistics

Standard

Displays standard statistics for the PAE Authenticator.

Enterprise

Displays enterprise statistics for the PAE Authenticator.

Supplicant PAE Info

Displays supplicant PAE information.

Supplicant PAE Statistics

Displays the statistics for the PAE supplicant.

MAC-based Authentication

PAE Port Info

Displays PAE port information.

Note - The Initialize parameter is implemented as 'read-only'.

Authenticator PAE Info

Displays authenticator PAE information.

Firewall Session Statistics

Displays the statistics for the firewall sessions.

RMON Menu

From the RMON menu you can view and edit the RMON MIB.

Statistics

Displays traffic statistics in the network segment attached to each port.

History Control Table

Displays the RMON History table.

Alarm Table

Displays the RMON Alarm table.

Event Table

Displays the RMON Event table.

Event Log

Displays the RMON Event log.

Port Menu

From the Port menu, you can view and edit MIB information about selected ports.

Utilization

Displays the port's utilization information.

Interface Info

Displays port statistics such as the number of frames received and transmitted on the port, bytes received and transmitted on the port, and port status. This table also displays high-capacity port statistics including received and transmitted unicast/multicast/broadcast packets on the port, link up/down trap and port speed.

Note - The current firmware version returns a 'noSuchName' value for the Port Alias and Counter Discontinuity Time parameters.

Detail Info

Duplex Mode

Displays the duplex mode of the ports.

Bandwidth Limits

Displays bandwidth limits of the switch ports.

Error Statistics

Displays error statistics.

Note - The following parameters are not applicable to the AT-x900-48 series and should be ignored:

- Ethernet Chip Set
- Symbol Errors
- Duplex Status

Spanning Tree Info

Displays the port's spanning tree parameters.

MAU Info

Displays interface-related MAU information for the port.

Note - The MAU Type List Bits and HC False Carriers parameters are not applicable to the AT-x900-48 series and should be ignored.

Note - The MAU Status and Default MAU Type parameters are implemented as 'read-only'.

MAU Negotiation Info

Displays the MAU's auto-negotiation settings and its status.

Note - The following parameters are not applicable to the AT-x900-48 series and should be ignored:

- Capability Bits
- Advertised Bits
- Received Bits
- Remote Fault Advertised
- Remote Fault Received

Note - The Administration Status, Advertised Negotiation Capability and Restart parameters are implemented as 'read-only'.

Port Trunking

Aggregator Port List

Displays Link Aggregation Control information for every Aggregation Port associated with this device.

Note - The following parameters are implemented as 'read-only':

- Actor Operational Key
- Partner Administrative System Priority
- Partner Administrative System ID
- Partner Administrative Key
- Partner Administrative Port
- Partner Administrative Port Priority
- Actor Administrative Status
- Partner Administrative Status

LACP Statistics

Displays Link Aggregation information for every port that is associated with this device.

LACP Debug

Displays Link Aggregation debug information for every port that is associated with this device.

Enable

Enables the port.

Disable

Disables the port.

Rapier

This section describes Device Manager menus and operations specific to Rapier Layer 3 Fast Ethernet Switches.

Topics:

- Main Window
- Agent Menu
- Routing Menu
- Bridge Menu
- Frame Relay Menu
- Call List Menu
- Port Menu

Main Window

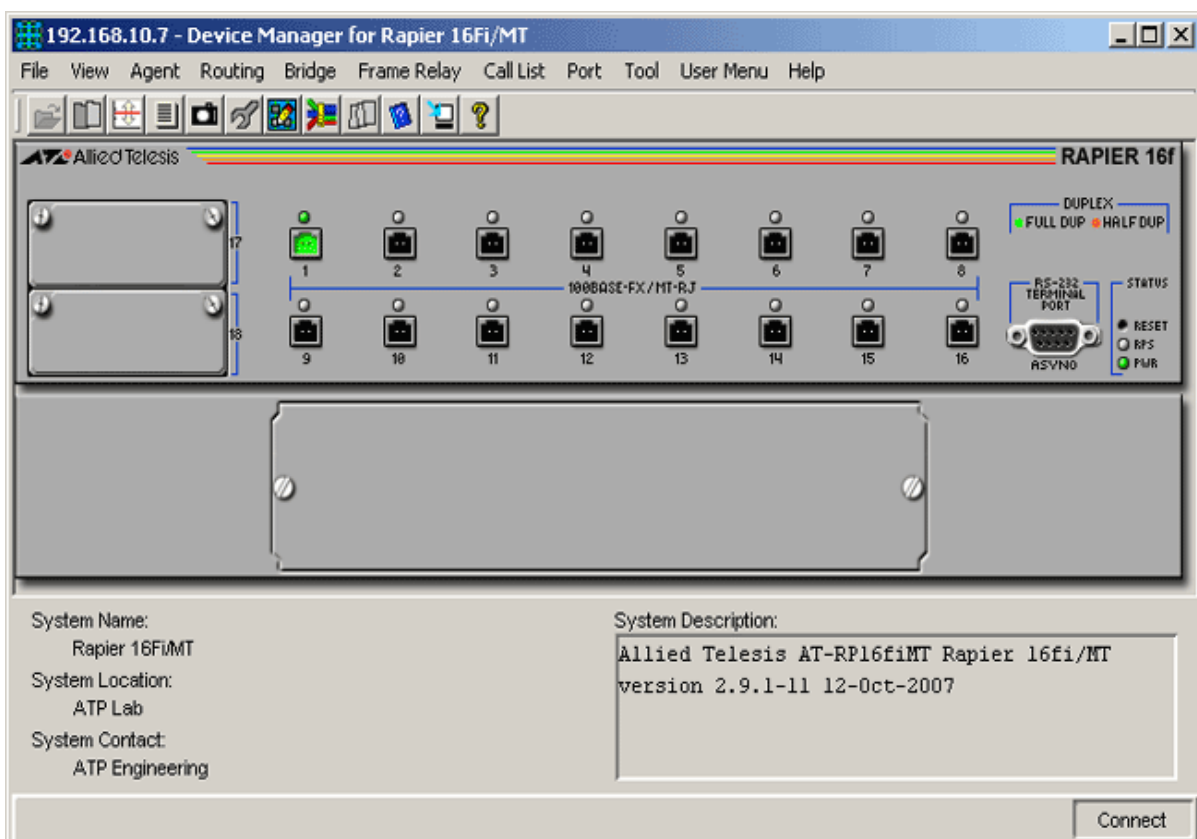

Rapier 16Fi/MT

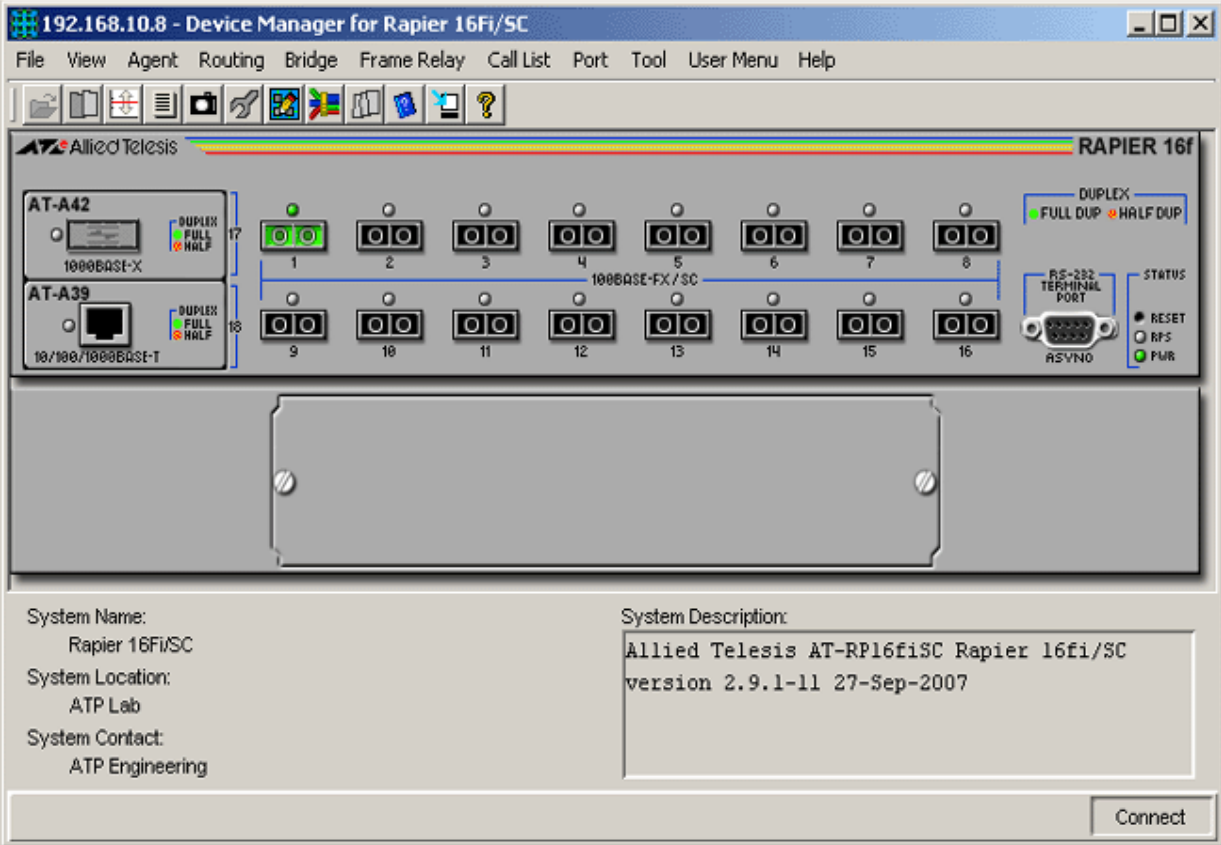

Rapier 16Fi/SC

192.168.10.21 - Device Manager for Rapier 24i

File View Agent Routing Bridge Frame Relay Call List Port Tool User Menu Help

Allied Telesis RAPIER 24i

AT-A39 10/100/1000BASE-T

10BASE-T/100BASE-TX

1 3 5 7 9 11 13 15 17 19 21 23
 2 4 6 8 10 12 14 16 18 20 22 24

DUPLEX: FULL DUP (green) HALF DUP (red)

RS-232 TERMINAL PORT

STATUS: RESET (red), RPS (green), PWR (green)

AT-AR041 BRI-S/T

7 6 5 4 3 2 1 0

System Name: Rapier 24i
 System Location: ATP Lab
 System Contact: ATP Engineering

System Description:
 Allied Telesis AT-RP24i Rapier 24i version
 2.5.3-00 17-Jun-2003

Connect

Rapier 24i

192.168.10.21 - Device Manager for Rapier 48i

File View Agent Routing Bridge Port Tool User Menu Help

Allied Telesis RAPIER 48i

10BASE-T/100BASE-TX

1 3 5 7 9 11 13 15 17 19 21 23
 2 4 6 8 10 12 14 16 18 20 22 24

25 27 29 31 33 35 37 39 41 43 45 47
 26 28 30 32 34 36 38 40 42 44 46 48

DUPLEX: FULL DUP (green) HALF DUP (red)

RS-232 TERMINAL PORT

STATUS: RESET (red), RPS (green), PWR (green)

System Name: Rapier 48i
 System Location: ATP Lab
 System Contact: ATP Engineering

System Description:
 Allied Telesis AT-RP48i Rapier 48i version
 2.6.1-02 30-Oct-2003

Connect

Rapier 48i

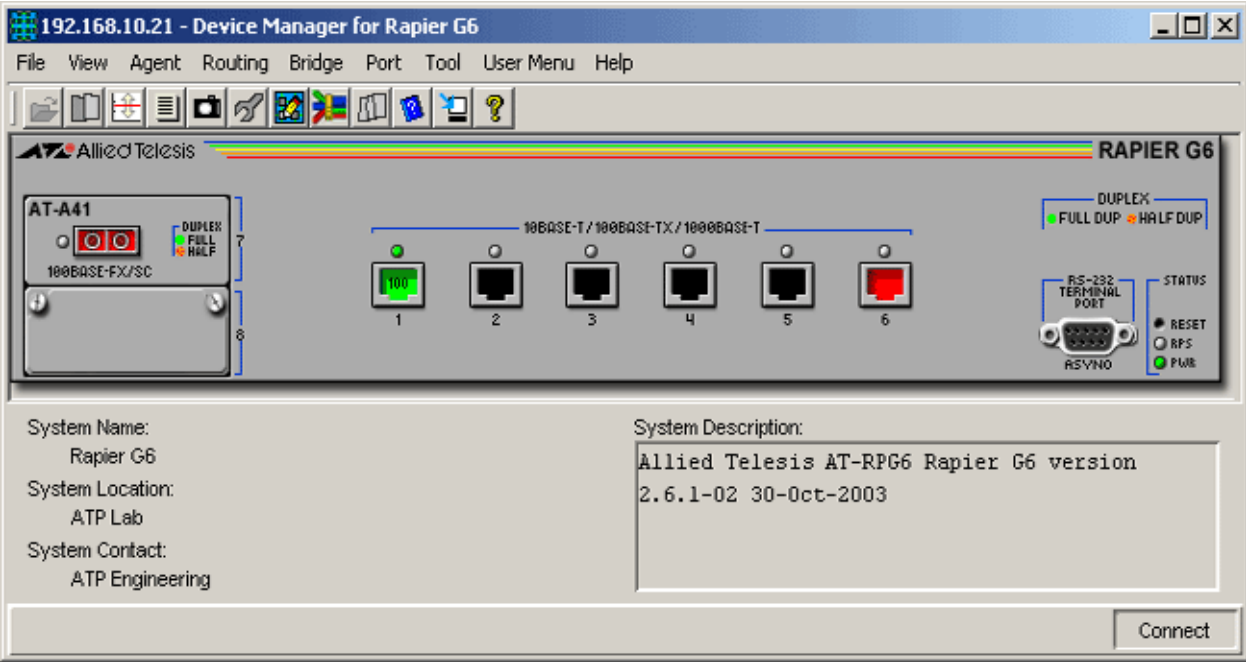

Rapier G6

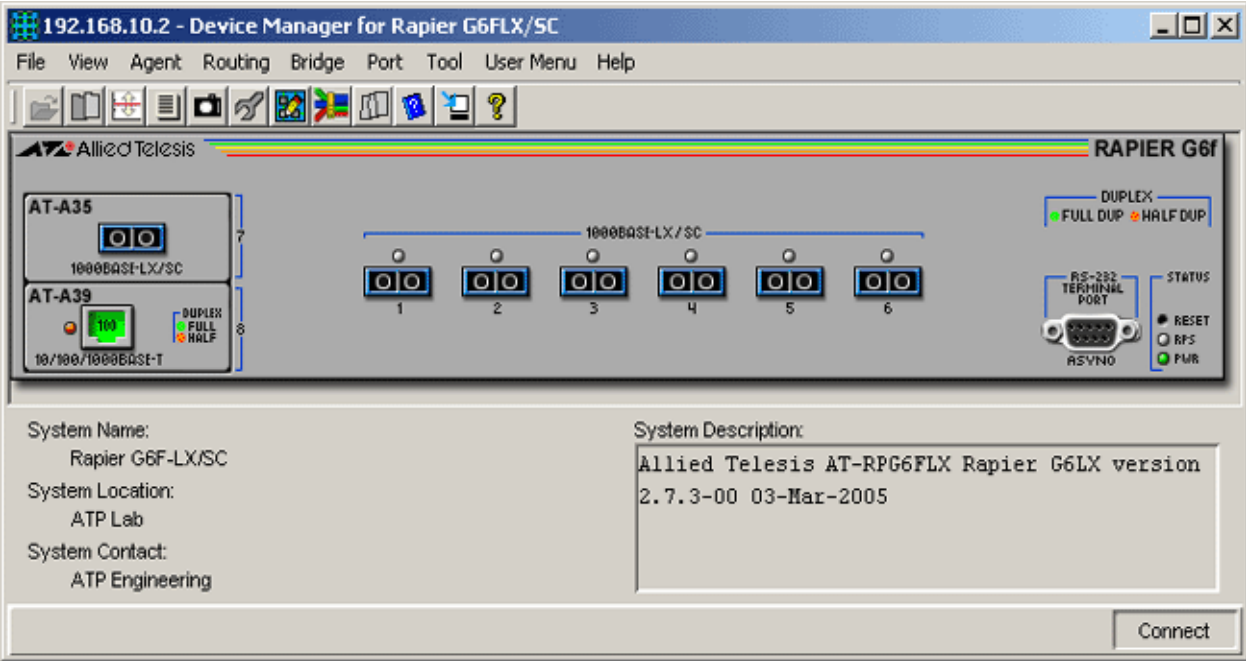

Rapier G6F-LX/SC

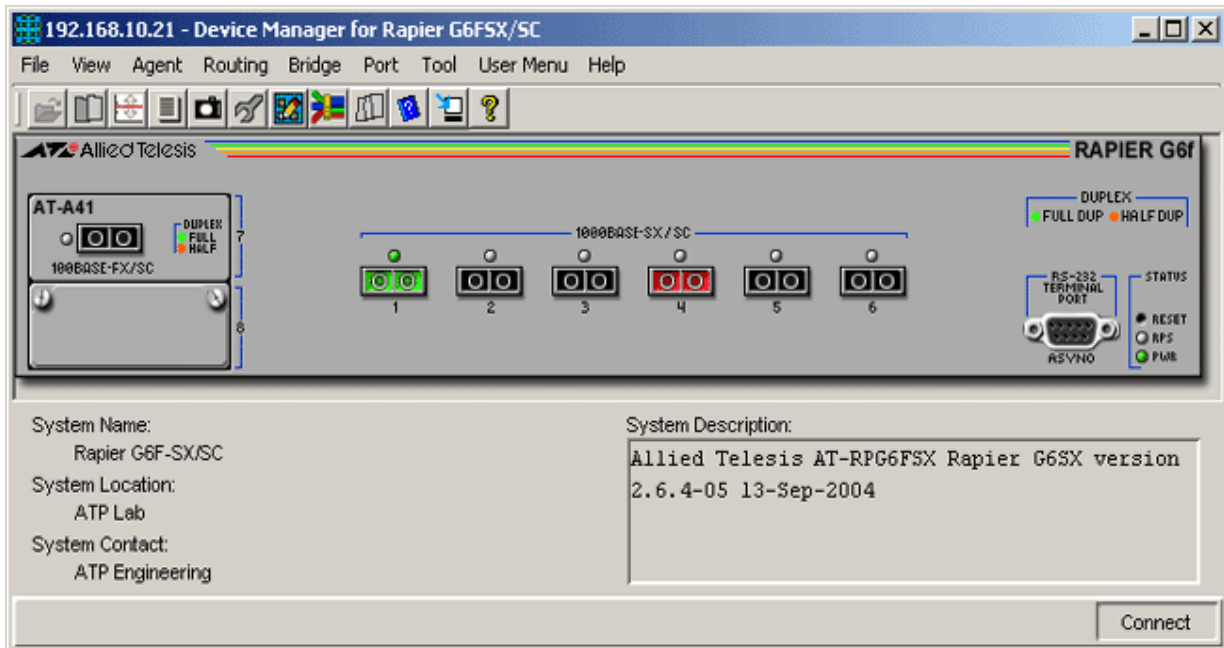

Rapier G6F-SX/SC

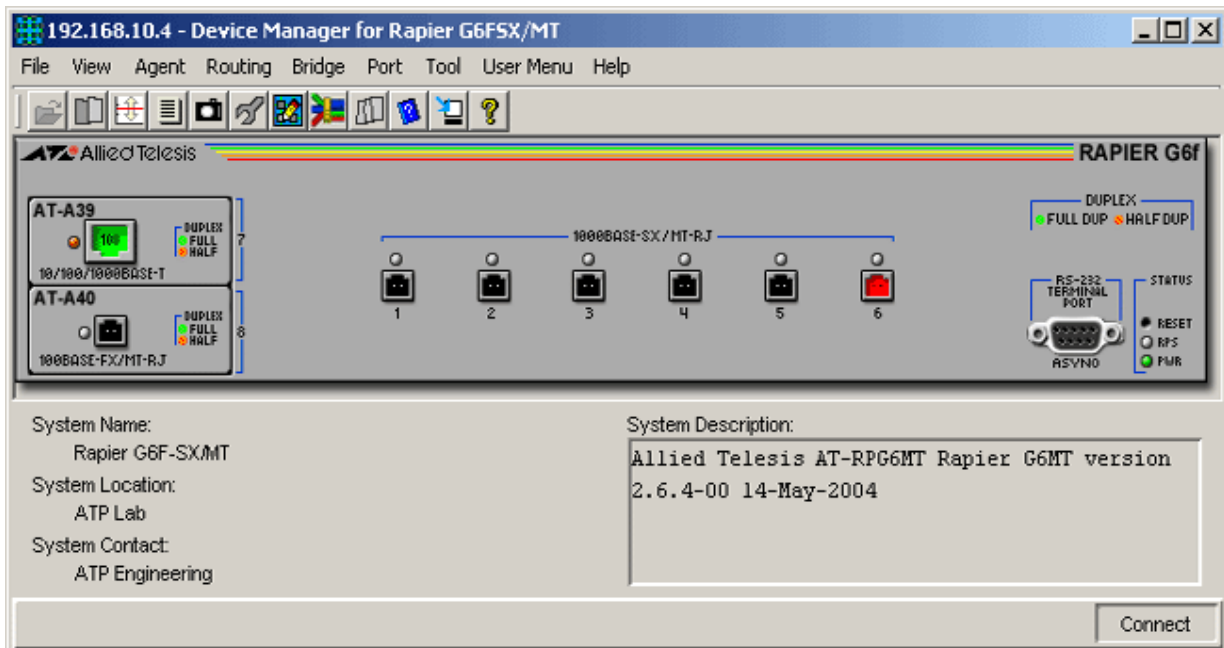

Rapier G6F-SX/MT

Device Manager LEDs for Rapiers		
LED	State	Description
PWR	Green	The switch is receiving power from the main power supply.
	Red	The main power supply has failed.
RPS	Green	The switch is receiving power from the redundant power supply.
	Red	RPS has failed.
	Gray	RPS is not installed or RPS monitoring is disabled.
DUPLEX	Green	The port is operating at full duplex.
	Orange	The port is operating at half duplex.

Note - The current firmware version does not allow Device Manager to support the Reset button.

Note - Please refer to Uplink Modules for the operations and behavior of the uplink modules installed in these devices.

Note - Please refer to Network Service Modules for the operations and behavior of the Network Service Modules installed in these devices.

Note - To turn RPS monitoring on or off on the switch, enter the command `SET SYSTEM RPSMONITOR={ON|OFF}` from the command line interface. To see whether RPS monitoring is on, use the command `SHOW SYSTEM`. To turn on RPS monitoring using SNMP, set the `fanAndPsRpsMonitoringStatus` variable to on.

Agent Menu

From the Agent menu, you can view and edit the system information for the switch, or log into the CLI using Telnet.

System Info

Displays basic system information, including system name, location, contact and description.

Power Supply Info

Displays information about the power supply, redundant power supply and power supply monitoring.

File List

Displays a list of the files in the switch's file system.

Config File Name

Displays the file name of the start-up configuration file.

Telnet

Starts a Telnet connection to the switch.

WEB Browser

Opens your web browser and connects to the switch's HTTP server.

Note - The web browser can only contact the device if the device has a valid resource file loaded and set, and the HTTP server and GUI on the device are enabled.

Routing Menu

From the Routing menu, you can view and edit information about the switch's IP routing functions.

ARP Table

Displays the mapping of IP addresses to MAC addresses (the ARP cache), on the switch.

Address Table

Displays the list of IP interfaces and their IP addresses on the switch.

Route Table

Displays the IP routing table on the switch.

IP Statistics

Displays statistics about IP routing, including the number of IP datagrams received.

ICMP Statistics

Displays statistics about ICMP, including the number of ICMP datagrams received.

Bridge Menu

From the Bridge menu, you can view and edit bridge information such as the forwarding database and the spanning tree status.

Forwarding Database

Standard View

Displays the Forwarding Database table as returned by the device.

Enhanced View

Displays the Forwarding Database table on a per port basis. User can select a port or group of ports to view its corresponding Forwarding Database entries.

Discard/Aging Time Info

Displays information about the number of address entries that were learned but discarded because either there was a lack of memory or the entry's aging timer expired.

Spanning Tree Info

Displays spanning tree parameters such as priority and cost.

Statistics

Displays statistics about frames received/transmitted on the switch port.

Frame Relay Menu

From the Frame Relay menu you can view and edit Frame Relay information. The Frame Relay submenus are greyed out if the Frame Relay is not configured.

Note - The Frame Relay Menu does not apply to the Rapier 48i, Rapier G6, Rapier G6F-LX/SC, Rapier G6F-SX/SC and Rapier G6F-SX/MT.

DLCMI Info

Displays DLCMI (Data Link Connection Management Interface) information.

Circuit Info

Displays Frame Relay circuit statistics.

Error Info

Displays information about errors related to the Frame Relay module.

Call List Menu

From the Call List menu, you can view ISDN call information. The Call List submenus are greyed out if the device is not configured for ISDN.

Note - The Call List Menu does not apply to the Rapier 48i, Rapier G6, Rapier G6F-LX/SC, Rapier G6F-SX/SC and Rapier G6F-SX/MT.

Detail Info

Displays ISDN call information such as ISDN number and call direction for active calls.

Active call

Displays information about currently active ISDN calls.

Port Menu

From the Port menu, you can view and edit MIB information about the port.

Utilization

Displays the port's utilization information.

Interface Info

Displays port statistics such as the number of frames received and transmitted on the port, bytes received and transmitted on the port, and port status.

Error Statistics

Displays error statistics.

Spanning Tree Info

Displays the port's spanning tree parameters.

Enable

Enables the port.

Disable

Disables the port.

Rapier

AT-Rapier 48w

This section describes Device Manager menus and operations specific to the AT-Rapier 48w switch.

Topics:

- Main Window
- Agent Menu
- Routing Menu
- LAN/WAN Menu
- Availability Menu
- Security Menu
- RMON Menu
- Port Menu

Main Window

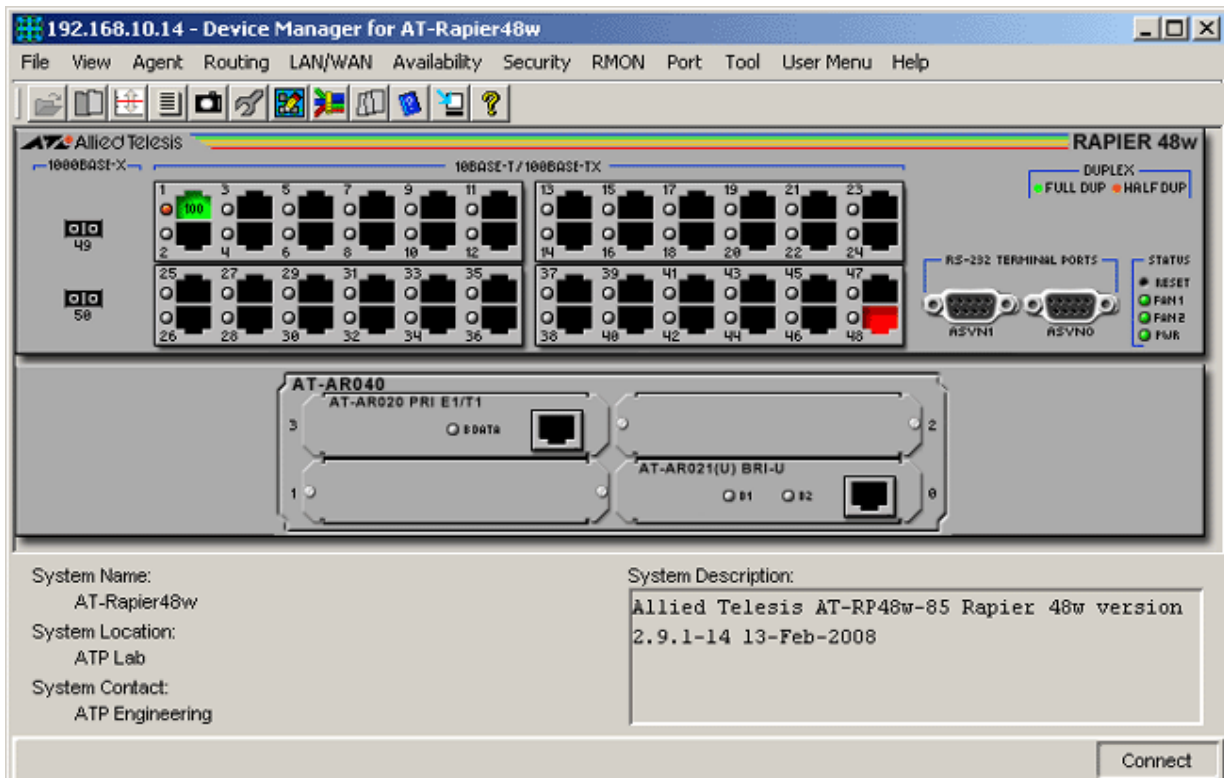

AT-Rapier 48w

Device Manager LEDs for the AT-Rapier 48w		
LED	State	Description
PWR	Green	The router is receiving power from the main power supply unit.
FAN 1 and FAN 2	Green	The FAN module is present and is turned on.
	Gray	The FAN module is not present.
DUPLEX	Green	The port is operating at full-duplex.
	Orange	The port is operating at half duplex.

Agent Menu

From the Agent menu, you can view and edit the system information for the router, or log into the CLI using Telnet.

System Info

Standard

Displays basic system information, including system name, location, contact and description.

Enterprise

CPU Utilization

Displays information about the CPU utilization over different periods of time.

Power Supply Info

Displays information about the power supply, redundant power supply and power supply monitoring.

Fan and Power Supply

Displays information about type and status of the Fan and PSU.

Note - The current firmware version returns a 'noSuchName' value for the Power Supply Unit Power Status parameter.

Temperature

Displays information about the temperature monitored by the temperature sensors in the device.

Note - The current firmware version does not allow the Temperature Threshold parameter to be configured.

Host Resources

General System Info

Displays general information about the host resources.

Note - Device Manager does not handle objects of type OCTET STRING correctly. As a result, the Time and Date parameter will display a sequence of bytes in hexadecimal format instead of the actual date and time of day.

Note - The Time and Date and Initial Load Parameter parameters are implemented as 'read-only'.

Logical Storage Areas

Displays resource information about the storage devices.

Note - The Storage Size parameter is implemented as 'read-only'.

Devices

Displays resource information about the devices installed in the host.

Hardware Info

Total Boards

Displays the number of boards that are currently installed.

Board Info

Displays basic information on the boards that are currently installed.

Slot Info

Displays information on the Power Supply Bay slots.

Physical Interfaces

Displays information about the interfaces found in the device.

Note - The Per Board submenu will appear under the Physical Interfaces menu if one or more PIC/s in the Network Service Module is/are installed.

Firmware Info

Install Configurations

Displays information about the Software release currently loaded in the device.

Note - The current firmware version returns a 'noSuchName' value for the Release File Exists? and Patch File Exists? parameters.

Install History

Displays information about the install history.

Configuration File

Displays the Configuration file name.

Release Licenses

Displays a list of software releases installed on the switch.

Note - The current firmware version does not allow any of the parameters under this table to be configured.

File System

Total Files

Displays the total number of files stored in the device.

File List

Displays a list of the files in the switch's file system.

Loader

Load Status

Displays the status of the device loader.

Load Parameters

Displays information about the files to be loaded.

LLDP Configuration

General Config

Displays basic LLDP configuration.

Port Config

Displays LLDP configuration for each port.

Note - Device Manager does not handle objects of type BITS correctly. As a result, the TLVs Tx Enable parameter will not be configurable and will display an 8-bit binary string instead of the actual TLV types allowed. However, the TLV types allowed can still be determined by looking at the bits that are on from left to right:

- Bit 0 - Port Description
- Bit 1 - System Name
- Bit 2 - System Description
- Bit 3 - System Capabilities

LLDP Statistics

Remote Tables

Displays statistics for the LLDP remote tables.

Port Tx

Displays statistics for LLDP frames transmitted.

Port Rx

Displays statistics for received LLDP frames.

Local System Data

General Info

Displays information about the local LLDP system.

Port Info

Displays information on the LLDP of local ports.

Note - The current firmware version returns the value 'NULL' for the Circuit parameter.

Management Addresses

Displays management addresses of the local LLDP system.

Note - Device Manager does not handle objects of type OCTET STRING correctly. As a result, the Port Tx Enable parameter will not be configurable and will display a sequence of bytes in hexadecimal format instead of the actual input value.

Note - The current firmware version returns the value 'NULL' for the OID parameter.

Reset Cold

Initiates a cold restart on the switch.

Reset Warm

Initiates a warm restart on the switch.

Reset Info

Displays information about the restart.

Telnet

Starts a Telnet connection to the switch.

WEB Browser

Opens your web browser and connects to the switch's HTTP server.

Note - The web browser can only contact the device if the device has a valid resource file loaded and set, and the HTTP server and GUI on the device are enabled.

Routing Menu

From the Routing menu, you can view and edit information about the router's IP routing functions.

IP

ARP Table

Displays the ARP cache on the switch.

Note - The Physical Address and Mapping Type parameters are implemented as 'read-only'.

Address Table

Displays the list of IP interfaces on the switch.

Route Number

Displays the IP routing number on the switch.

Route Table

Displays the IP routing table on the switch.

Note - The current firmware version returns the value 'NULL' for the Routing Protocol MIB parameter.

Note - The following parameters are implemented as 'read-only':

- Destination Port Number
- Routing Type
- Nexthop AS Number
- Destination Metric 1
- Destination Metric 2
- Destination Metric 3
- Destination Metric 4
- Destination Metric 5
- Row Status

IP Statistics

Displays statistics about IP, such as the number of IP datagrams received.

Note - The Default TTL parameter is implemented as 'read-only'.

UDP

Listener Info

Displays UDP listener information.

UDP Statistics

Displays UDP statistics.

TCP

Connection Info

Displays TCP connection-specific information.

Note - The Connection Status parameter is implemented as 'read-only'.

TCP Statistics

Displays TCP statistics.

ICMP Statistics

Displays ICMP statistics.

DHCP Ranges

Displays information about the DHCP module.

BGP

General Info

Displays information about the BGP module.

Peer Info

Displays BGP Peer information.

Note - The current firmware version does not allow the following parameters to be configured:

- Connect Retry Interval
- Configured Hold Time
- Configured Keep Alive
- Min AS Origination Interval
- Min Route Advertisement Interval

Path Attributes

Displays the BGP path attributes.

LAN/WAN Menu

From the LAN/WAN menu, you can view and edit information for the LAN/WAN such as the frame relay and ISDN-related information. The submenus are unavailable if the proper PICs are not installed.

Bridging

Forwarding Database

Standard View

Displays the Forwarding Database table as returned by the device.

Enhanced View

Displays the Forwarding Database table on a per port basis. User can select a port or group of ports to view its corresponding Forwarding Database entries.

Discard/Aging Time Info

Displays information about the number of address entries that were learned but discarded for reasons such as lack of memory or the entry's aging timer.

Spanning Tree Info

Displays spanning tree parameters such as priority and cost.

Note - Valid MIB Set values for the Port Path Cost parameter are in the range [1 - 65535] inclusive. Attempting to set this parameter to a value outside of the valid range will result in the error message: "The error occurred with 'Set' operation. Error: bad value."

Statistics

Displays statistics about frames received/transmitted on the switch port.

Basic Bridge Info

Displays basic bridge information.

Bridge Port Info

Displays bridge port information.

ISDN

Call Details

Displays ISDN call information such as ISDN number and call direction for active calls.

Note - If the In CLI (Calling Line Info) Search parameter is set to 'list', the In CLI (Calling Line Info) List Check parameter gives the index of the CLI list to search. The value of CLI list indices ranges from 1 to 100. The value 0 is returned if the In CLI (Calling Line Info) Search parameter is not set to 'list'. When the In CLI (Calling Line Info) List Check parameter is set to 0, the In CLI (Calling Line Info) Search parameter is internally set to 'off'. Subsequently setting it to a non-zero value will set the In CLI (Calling Line Info) Search parameter to 'list'. Note that when using the command line interface, CLI List indices range from 0 to 99, but when using Device Manager, they range from 1 to 100. This is because SNMP will not allow a table index to have the value 0, and the command line usage of indices from 0 to 99 is too well established to change.

Note - If the In CLI (Calling Line Info) Check parameter is set to 'present' or 'required', the In CLI (Calling Line Info) Check List parameter gives the index of the CLI list to check against. The value of CLI list indices ranges from 1 to 100. The value 0 means that no list to check against is defined and the check immediately fails. Note that when using the command line interface, CLI list indices range from 0 to 99, but when using Device Manager, they range from 1 to 100. This is because SNMP will not allow a table index to have the value 0, and the command line usage of indices from 0 to 99 is too well established to change.

Note - The PPP Template parameter specifies the PPP template to use when creating dynamic PPP interfaces for calls generated. The value 33 represents a default PPP template while the values 1 to 32 represent PPP templates that are currently defined in the router. Note that when using the command line interface, PPP template indices range from 0 to 31, but when using Device Manager, they range from 1 to 32. This is because SNMP will not allow a table index to have the value 0.

CLI List

Displays the Calling Line Information list.

Active Calls

Displays information about currently active ISDN calls.

Call Log

Displays the call logs.

Call Detail Attachments

Displays call detail attachment information.

B Channel Attachments

Displays B Channel attachment information.

BRI Interfaces

Displays BRI interface information.

BRI Channels

Displays BRI channels information.

PRI Interfaces

Displays PRI interface information.

PRI Channels

Displays PRI channels information.

Frame Relay

DLC Management Interfaces

Displays DLCMI (Data Link Connection Management Interface) information.

Virtual Circuits

Displays Frame Relay circuit statistics.

Errors

Displays information about errors related to the Frame Relay module.

DSI

DSI Config

Displays DSI configuration

Note - The current firmware version returns a 'noSuchName' value for the Port Number parameter.

Near-End

Current 15-Min Interval Statistics

Displays near-end DSI statistics every 15 minutes.

Statistics for Past 24 Hours

Displays near-end DSI statistics for the past 24 hours.

Cumulative Statistics

Displays accumulated near-end DSI statistics.

Far-End

Current 15-Min Interval Statistics

Displays far-end DSI statistics every 15 minutes.

Statistics for Past 24 Hours

Displays far-end DSI statistics for the past 24 hours.

Cumulative Statistics

Displays accumulated far-end DSI statistics.

Availability Menu

From the Availability menu you can view and edit Server Load Balancing and Ping Polling information.

Server Load Balancing

General Info

Displays basic server load balancing information.

Resources

Displays server load balancing resources information.

Resource Pools

Displays server load balancing resource pools information.

Virtual Balancers

Displays virtual balancers information.

Affinity Tables

Displays load balancer affinities information.

Open TCP Connections

Displays open TCP connections information.

Ping Polling

Ping Status

Displays the status of the Ping polling.

Note - The current firmware version does not allow the Ping Status parameter to be configured.

Ping Parameters

Displays basic information of the Ping module.

Note - Valid MIB Set values for the Timeout parameter should range from 1 to 60. However, the current firmware version allows the user to enter values in the range [-4294967295 to -1, 1 to 4294967295] inclusive. But attempting to enter values greater than 65535 will cause the new value to be converted to its equivalent wrap-around value; i.e., 65536 will become 0, 65537 will become 1, and so on.

Note - Valid MIB Set values for the Time Interval parameter should range from 0 to 604800. However, the current firmware version allows the user to enter values in the range [-9223372036854775808 to 9223372036854775807] inclusive. But attempting to enter values greater than 999999999 will cause the new value to be converted to its equivalent wrap-around value; i.e., 9999999990 will become 1410065398, 9999999991 will become 1410065399, and so on.

Note - Valid MIB Set values for the Number of Packets parameter should range from 1 to 4294967295. However, the current firmware version does not allow Device Manager to display the correct value greater than 2147483647. Attempting to enter values greater than 2147483647 will cause the new value to be converted to its equivalent wrap-around value; i.e. 2147483648 will become -2147483648, 2147483649 will become -2147483647, and so on.

Note - The current firmware version only allows the Address parameter to be configured if the Protocol parameter is set to OSI.

Note - Valid MIB Set values for the Data Pattern parameter should range from [0-4294967295] inclusive. However the current firmware version does not allow Device Manager to display correct values greater than 4286578687. Attempting to enter values greater than 4286578687 will cause the new value to be converted to the following values:

- 4286578688 - 4294934527: 8388608 - 16744447
- 4294934528 - 4294967167: 32768 - 65407
- 4294967168 - 4294967295: 128 - 255

Ping Statistics

Displays statistics of the Ping polling.

Security Menu

From the Security menu, you can view and edit port access entity information such as the PAE port information and the Supplicant PAE information.

Port-based Authentication

Authentication Status

Displays the status of the port-based authentication.

PAE Port Info

Standard

Displays standard PAE port information.

Note - Device Manager does not handle objects of type BITS correctly. As a result, the Capabilities parameter will display an 8-bit binary string instead of the actual PAE functionality supported. However, the PAE functionality supported can still be determined by looking at the bits that are on from right to left:

- Bit 0 - Authenticator
- Bit 1 - Supplicant

Enterprise

Displays enterprise PAE port information.

Authenticator PAE Info

Standard

Displays standard authenticator PAE information.

Note - The Administrative Controlled Directions and Key Transmission Status parameters are implemented as 'read-only'.

Enterprise

Displays enterprise authenticator PAE information.

Authenticator PAE Statistics

Standard

Displays standard statistics for the PAE Authenticator..

Enterprise

Displays enterprise statistics for the PAE Authenticator.

Supplicant PAE Info

Displays supplicant PAE information.

Supplicant PAE Statistics

Displays the statistics for the PAE supplicant.

MAC-based Authentication

PAE Port Info

Displays the PAE port information.

Note - The Initialize parameter is implemented as 'read-only'.

Authenticator PAE Info

Displays authenticator PAE information.

Firewall Session Statistics

Displays the statistics for the firewall sessions.

RMON Menu

From the RMON menu you can view and edit the RMON MIB.

Statistics

Displays traffic statistics in the network segment attached to each port.

History Control Table

Displays the RMON History table.

Alarm Table

Displays the RMON Alarm table.

Event Table

Displays the RMON Event table.

Event Log

Displays the RMON Event log.

Port Menu

From the Port menu, you can view and edit MIB information about selected ports.

Utilization

Displays the port's utilization information.

Interface Info

Displays port statistics such as the number of frames received and transmitted on the port, bytes received and transmitted on the port, and port status. This table also displays high-capacity port statistics including received and transmitted unicast/multicast/broadcast packets on the port, link up/down trap and port speed.

Note - The current firmware version returns a 'noSuchName' value for the Port Alias and Counter Discontinuity Time parameters.

Note - Although the current firmware allows the Administration Status parameter to be set to 'testing', the value 'testing' is not a valid MIB Set value.

Note - The Promiscuous Mode parameter is implemented as 'read-only'.

Detail Info

Duplex Mode

Displays the duplex mode of the ports.

Bandwith Limits

Displays bandwidth limits of the switch ports.

Error Statistics

Displays error statistics.

Note - The following parameters are not applicable to AT-Rapier48w and should be ignored:

- Ethernet Chip Set
- Symbol Errors
- Duplex Status

Spanning Tree Info

Displays the port's spanning tree parameters.

MAU Info

Displays interface-related MAU information for the port.

Note - The MAU Type List Bits and HC False Carriers parameters are not applicable to the AT-Rapier48w and should be ignored.

Note - The MAU Status and Default MAU Type parameters are implemented as 'read-only'.

MAU Negotiation Info

Displays the MAU's auto-negotiation settings and its status.

Note - The following parameters are not applicable to the AT-Rapier48w and should be ignored:

- Capability Bits
- Advertised Bits
- Received Bits
- Remote Fault Advertised
- Remote Fault Received

Note - The Administration Status, Advertised Negotiation Capability and Restart parameters are implemented as 'read-only'.

Port Trunking

Aggregator Port List

Displays Link Aggregation Control information for every Aggregation Port associated with this device.

Note - The following parameters are implemented as 'read-only':

- Actor Operational Key
- Partner Administrative System Priority
- Partner Administrative System ID
- Partner Administrative Key
- Partner Administrative Port
- Partner Administrative Port Priority
- Actor Administrative Status
- Partner Administrative Status

LACP Statistics

Displays Link Aggregation information for every port that is associated with this device.

LACP Debug

Displays Link Aggregation debug information for every port that is associated with this device.

Enable

Enables the port.

Disable

Disables the port.

SwitchBlade

This section describes Device Manager menus and operations specific to the SwitchBlade Series, including the AT-SB4211 Switch Controller, power supply units and fan tray installed.

Topics:

- Main Window
- Agent Menu
- Routing Menu
- Bridge Menu
- Port Menu

Main Window

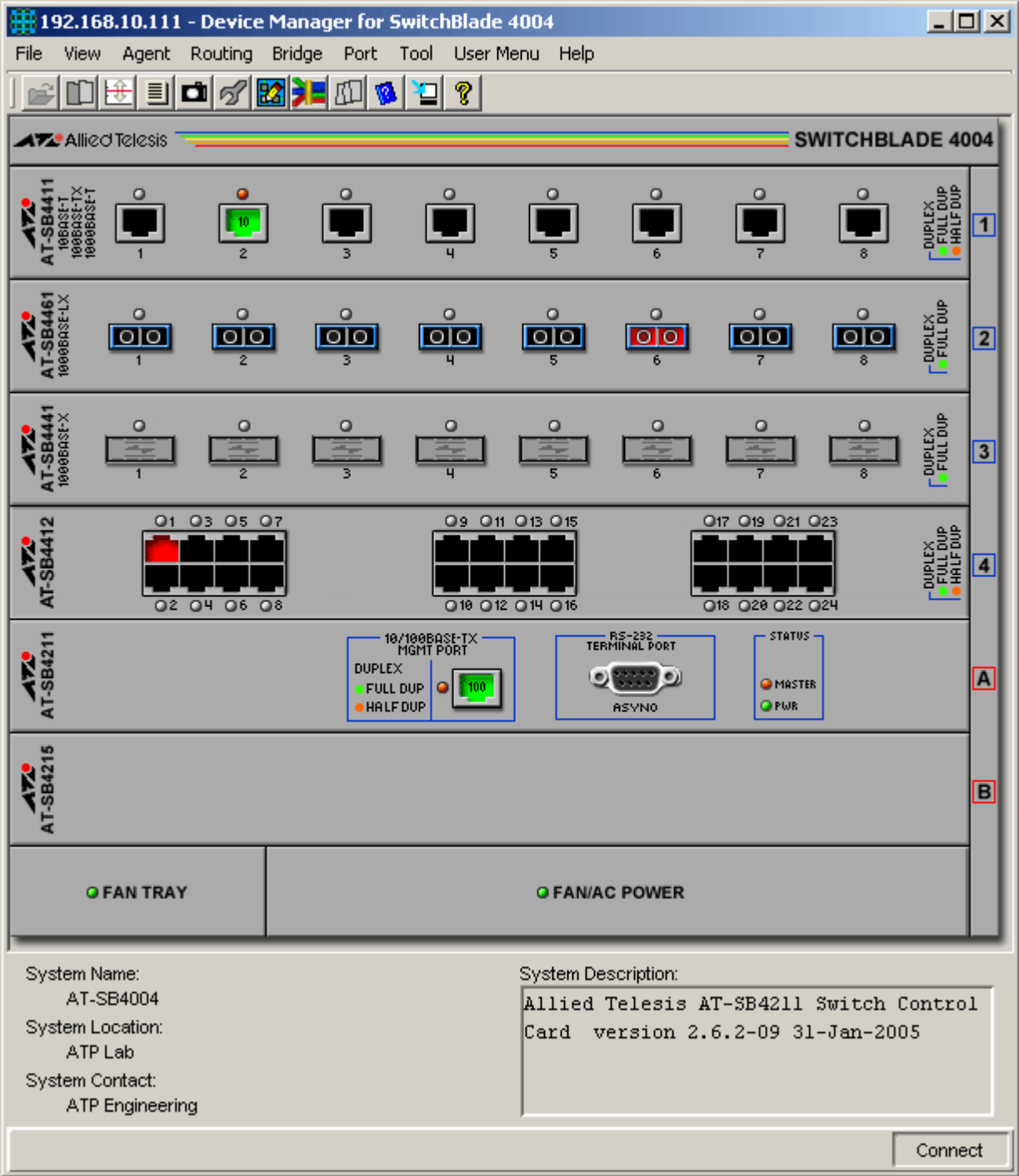

SwitchBlade 4004 with SB4211 Switch Controller, SB4215 Bandwidth Expander, and Line Cards installed

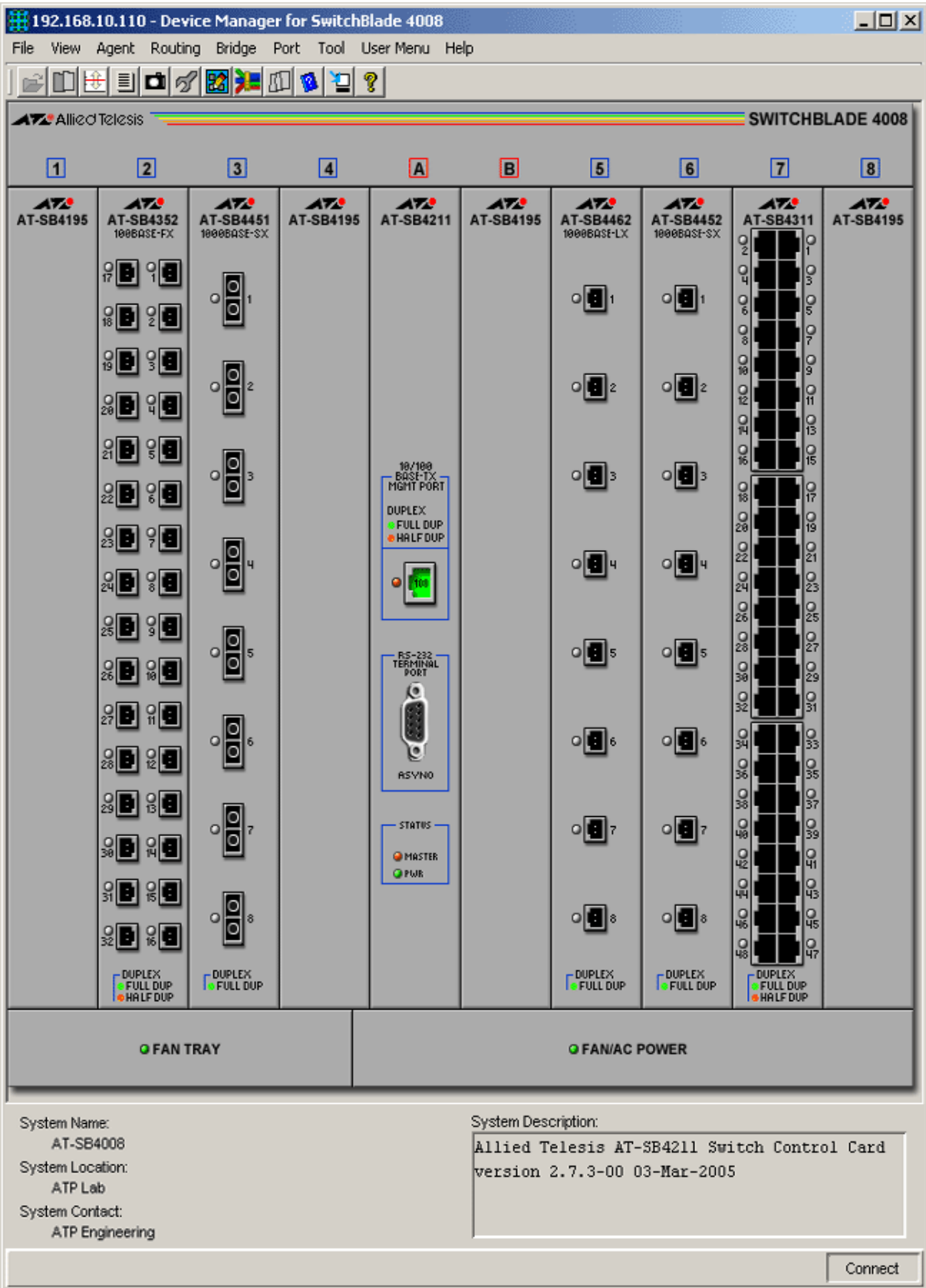

SwitchBlade 4008 with SB4211 Switch Controller and Line Cards installed

Device Manager LEDs for AT-SB4211 Switch Controller		
LED	State	Description
PWR	Green	The PSU is receiving power from its supply circuit.
MASTER	Orange	The card is the master switch controller.
	Gray	The card is a slave switch controller.
DUPLEX	Green	The port is operating at full duplex.
	Orange	The port is operating at half duplex.

Device Manager LEDs for Fan Tray and Power Supply Units (PSUs)		
LED	State	Description
FAN TRAY	Green	The fan tray is installed and functioning.
	Red	The fan tray is either not installed or not functioning.
FAN/AC POWER (For AC Model)	Green	The power supply units installed including the fans are fully operational.
	Red	One of the PSU installed or its fan is faulty.
FAN/DC POWER (For DC Model)	Green	The power supply units installed including the fans are fully operational.
	Red	One of the PSU installed or its fan is faulty.

Note - Please refer to SwitchBlade Line Cards for the operations and behavior of the line cards installed on these devices.

Note - There is no distinction between one or more PSUs. The FAN/AC POWER and FAN/DC POWER LEDs show information for all PSUs installed in the device.

Agent Menu

From the Agent menu, you can view and edit the system information for the switch, or log into the CLI using Telnet.

System Info

Displays basic system information, including system name, location, contact and description.

File List

Displays a list of the files in the switch's file system.

Config File Name

Displays the file name of the start-up configuration file.

Boards Info

Displays information about the chassis board, and switch controller and line card boards installed in the device.

Telnet

Starts a Telnet connection to the switch.

WEB Browser

Opens your web browser and connects to the switch's HTTP server.

Note - The web browser can only contact the device if the device has a valid resource file loaded and set, and the HTTP server and GUI on the device are enabled.

Routing Menu

From the Routing menu, you can view and edit information about the switch's IP routing functions.

ARP Table

Displays the mapping of IP addresses to MAC addresses (the ARP cache), on the switch.

Address Table

Displays the list of IP interfaces and their IP addresses on the switch.

Route Table

Displays the IP routing table on the switch.

IP Statistics

Displays statistics about IP routing, including the number of IP datagrams received.

ICMP Statistics

Displays statistics about ICMP, including the number of ICMP datagrams received.

Bridge Menu

From the Bridge menu, you can view and edit bridge information such as the forwarding database and the spanning tree status.

Forwarding Database

Standard View

Displays the Forwarding Database table as returned by the device.

Enhanced View

Displays the Forwarding Database table on a per port basis. User can select a port or group of ports to view its corresponding Forwarding Database entries.

Note - The current firmware version may, at times, return duplicate Forwarding Database table entries.

Discard/Aging Time Info

Displays information about the number of address entries that were learned but discarded because either there was a lack of memory or the entry's aging timer expired.

Spanning Tree Info

Displays spanning tree parameters such as priority and cost.

Statistics

Displays statistics about frames received/transmitted on the switch port.

Port Menu

From the Port menu, you can view and edit MIB information about the port. For each Port menu option, select first the slot in the SwitchBlade chassis, then the ports in the line card for which you require information. Note that the Port Number shown is the value of the MIB object ifIndex, except for the STP Info option, which shows the value of the MIB object dot1dBasePort.

Utilization

Displays the port's utilization information.

Interface Info

Displays port statistics such as the number of frames received and transmitted on the port, bytes received and transmitted on the port, and port status.

Detail Info

Displays detailed information about the ports, including multicast and broadcast packets received and transmitted.

Error Statistics

Displays error statistics.

Spanning Tree Info

Displays the port's spanning tree parameters. The Port Number displayed is the MIB object dot1dBasePort.

Enable

Enables the port.

Disable

Disables the port.

SwitchBlade

SwitchBlade Line Cards

This section describes the SwitchBlade Line Cards in Device Manager. If the following Line Cards are installed in a SwitchBlade chassis, they are displayed in the main window. The operations available for the SwitchBlade include any of these line cards.

- AT-SB4311
- AT-SB4352
- AT-SB4411
- AT-SB4412
- AT-SB4441
- AT-SB4442
- AT-SB4451
- AT-SB4452
- AT-SB4461
- AT-SB4462
- AT-SB4541

AT-SB4311 / AT-SB4352 / AT-SB4411 / AT-SB4412



48-Port (RJ-45) 10BASE-T/100BASE-TX Fast Ethernet Line Card



32-Port (MT-RJ) 100BASE-FX Fast Ethernet Line Card



8-Port (RJ-45) 10BASE-T/100BASE-TX/1000BASE-T Gigabit Ethernet Line Card

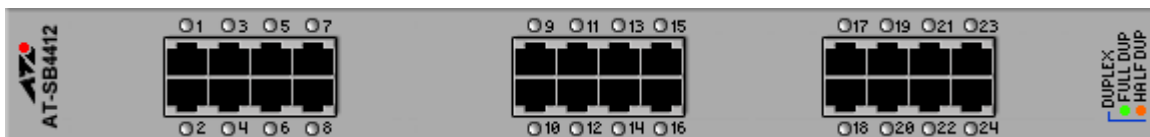

24-Port (RJ-45) 10BASE-T/100BASE-TX/1000BASE-T Gigabit Ethernet Line Card

LED	State	Description
DUPLEX	Green	The port is operating at full-duplex.
	Orange	The port is operating at half-duplex.

AT-SB4441

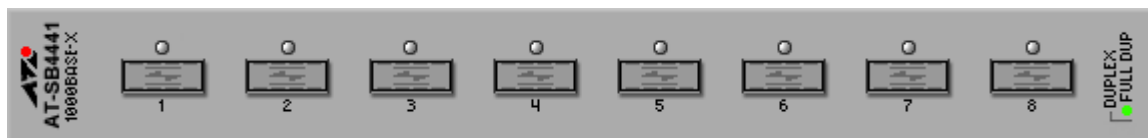

8-Port 1000BASE-X GBIC Line Card

LED	State	Description
DUPLEX	Green	The port is operating at full-duplex.

AT-SB4442

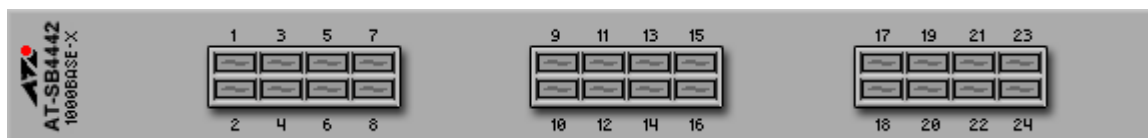

24-port 1000Base-X (SFP) Line Card

Note - There are no LEDs on this module.

AT-SB4451 / AT-SB4452 / AT-SB4461 / AT-SB4462

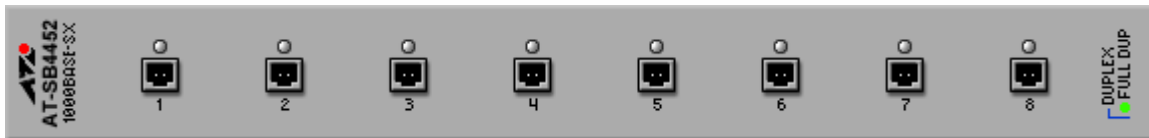
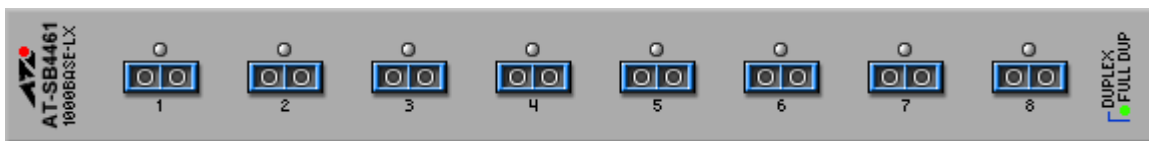
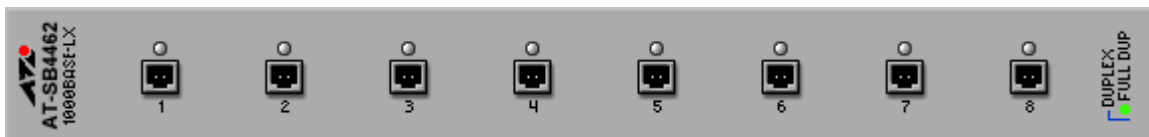
8-Port (SC) 1000BASE-SX Gigabit Ethernet Line Card

8-Port (MT-RJ) 1000BASE-SX Gigabit Ethernet Line Card

8-Port (SC) 1000BASE-LX Gigabit Ethernet Line Card

8-Port (MT-RJ) 1000BASE-LX Gigabit Ethernet Line Card

LED	State	Description
DUPLEX	Green	The port is operating at full-duplex.

AT-SB4541

1-port 10GBASE-R Line Card

LED	State	Description
XFP	Green	An XFP is installed and enabled.
	Orange	An XFP is installed, but disabled.
	Off	No XFP is installed.

Multi-Layer Gigabit Switches

AT-9400 Series

This section describes Device Manager menus and operations specific to the AT-9400 Series.

Topics:

- Main Window
- Agent Menu
- Routing Menu
- Bridge Menu
- Security Menu
- RMON Menu
- Port Menu
- Stacking Menu

Main Window

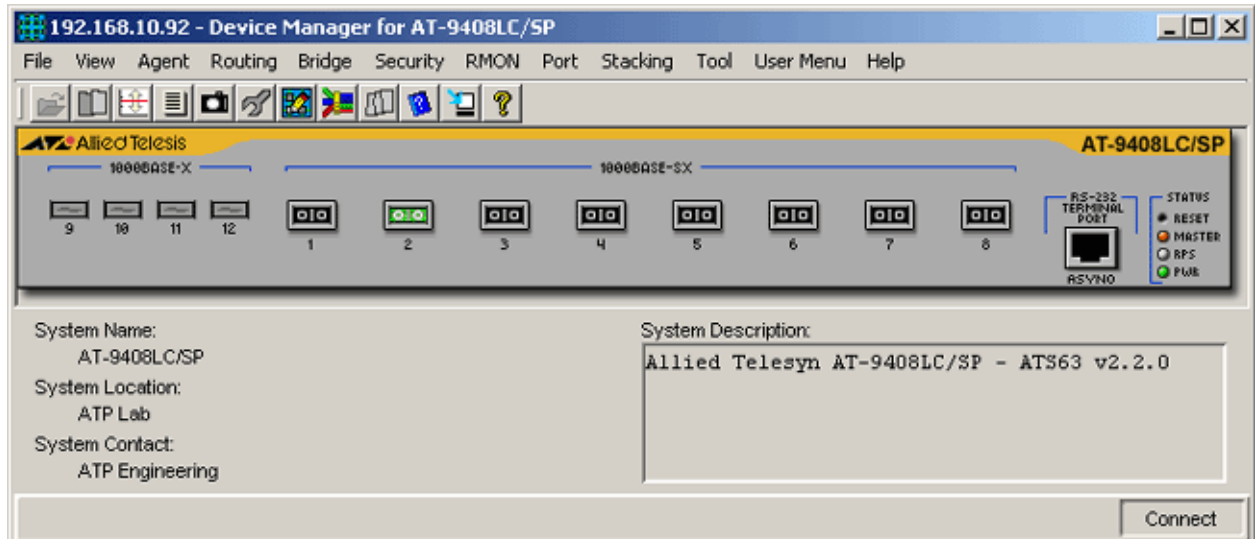

AT-9408LC/SP

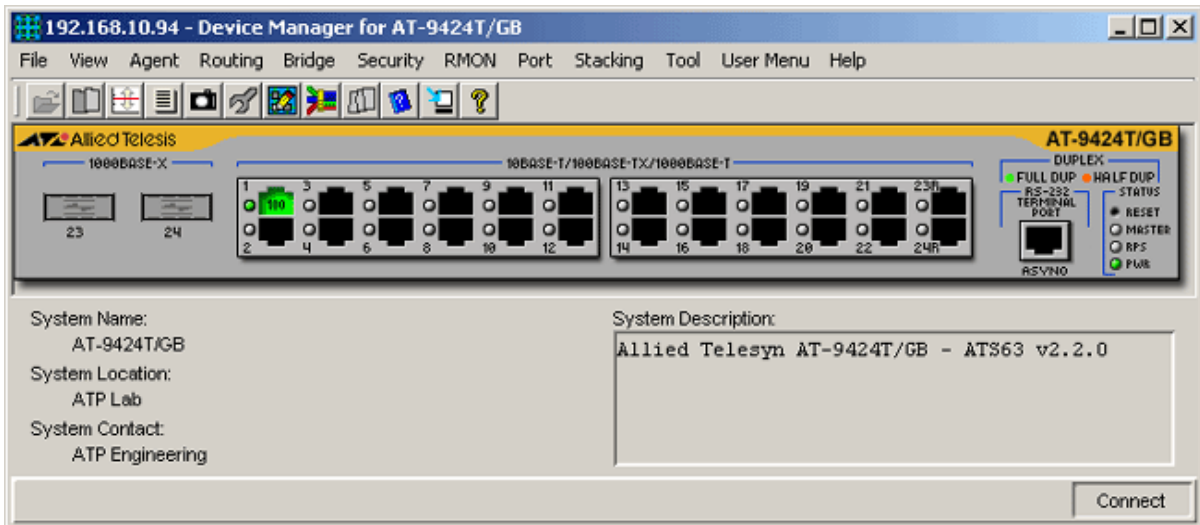

AT-9424T/GB

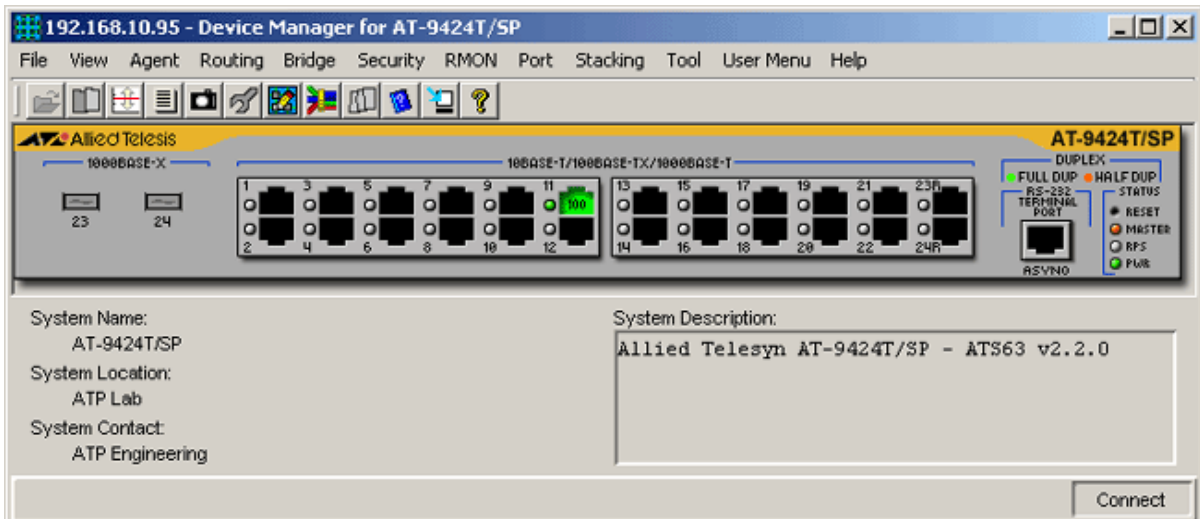

AT-9424T/SP

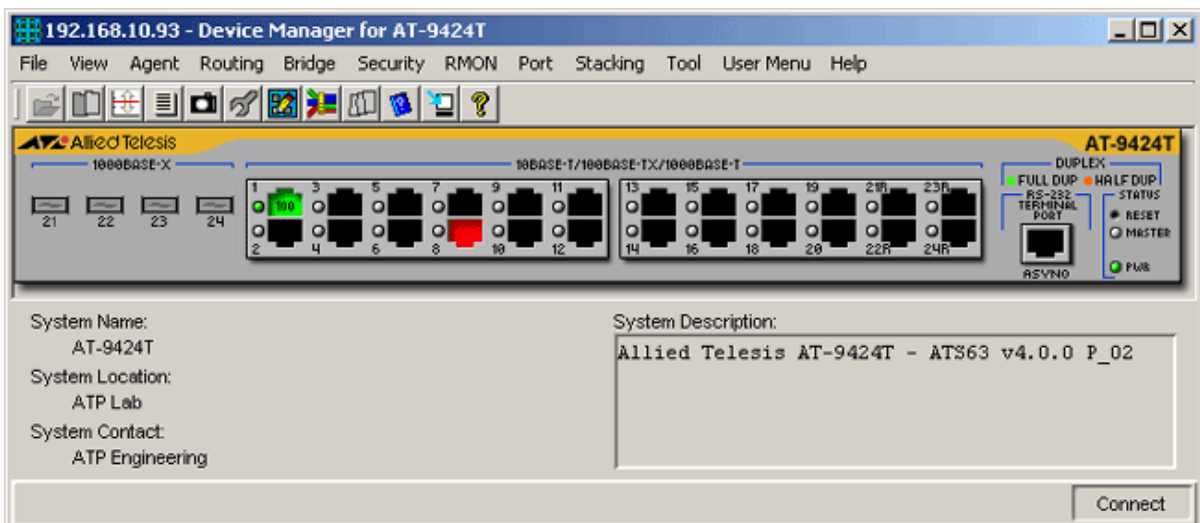

AT-9424T

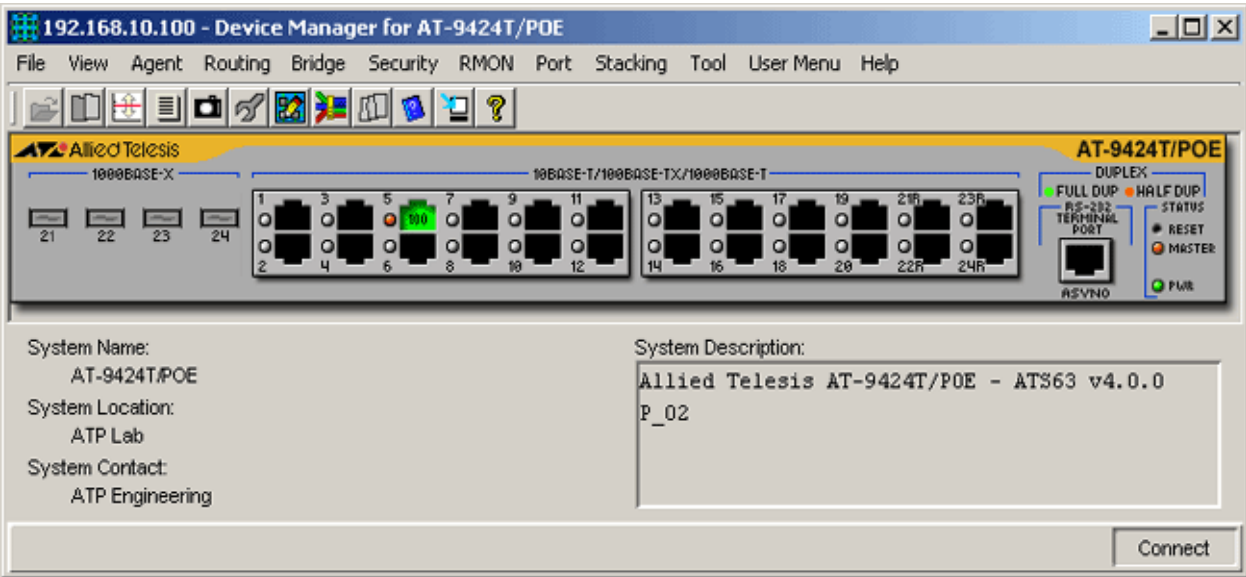

AT-9424T/POE

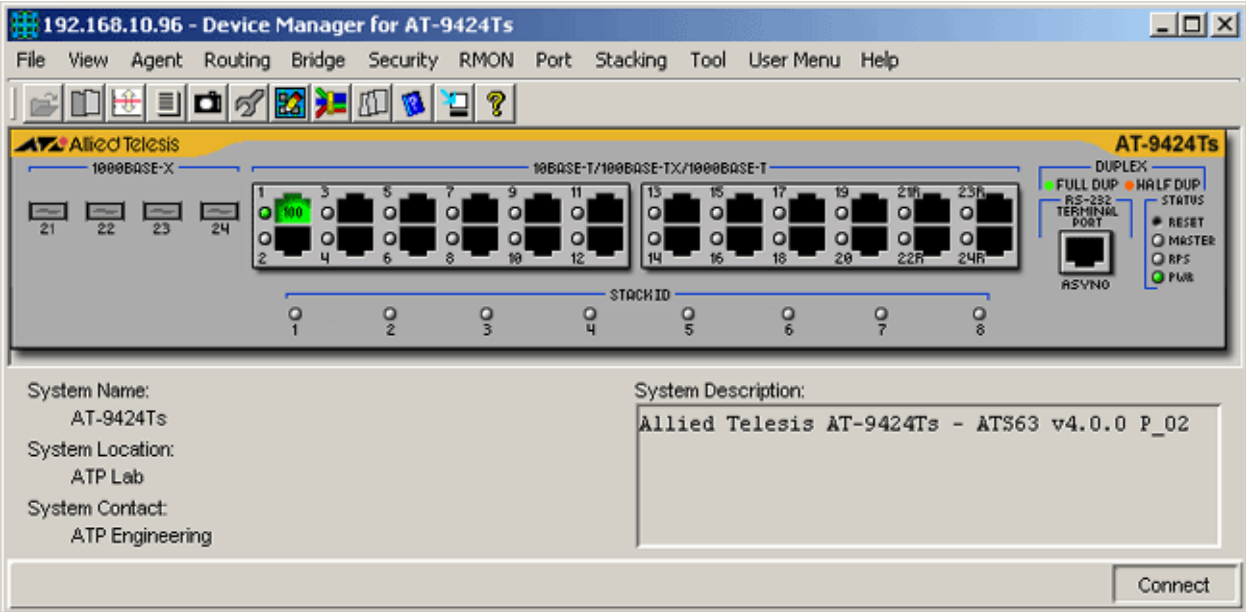

AT-9424Ts

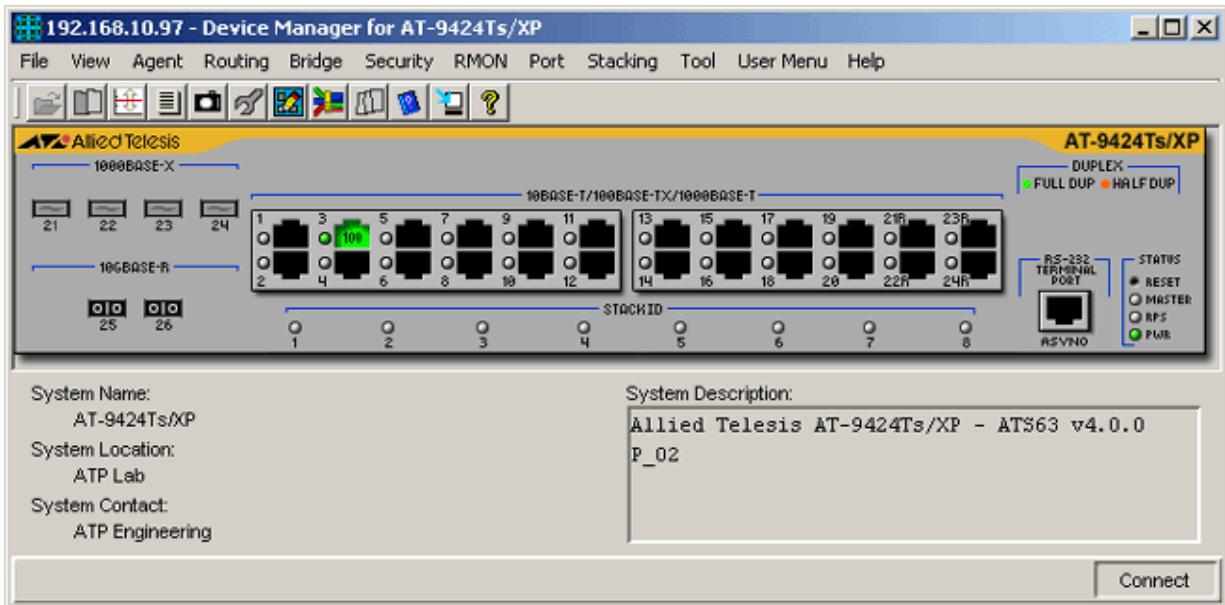

AT-9424Ts/XP

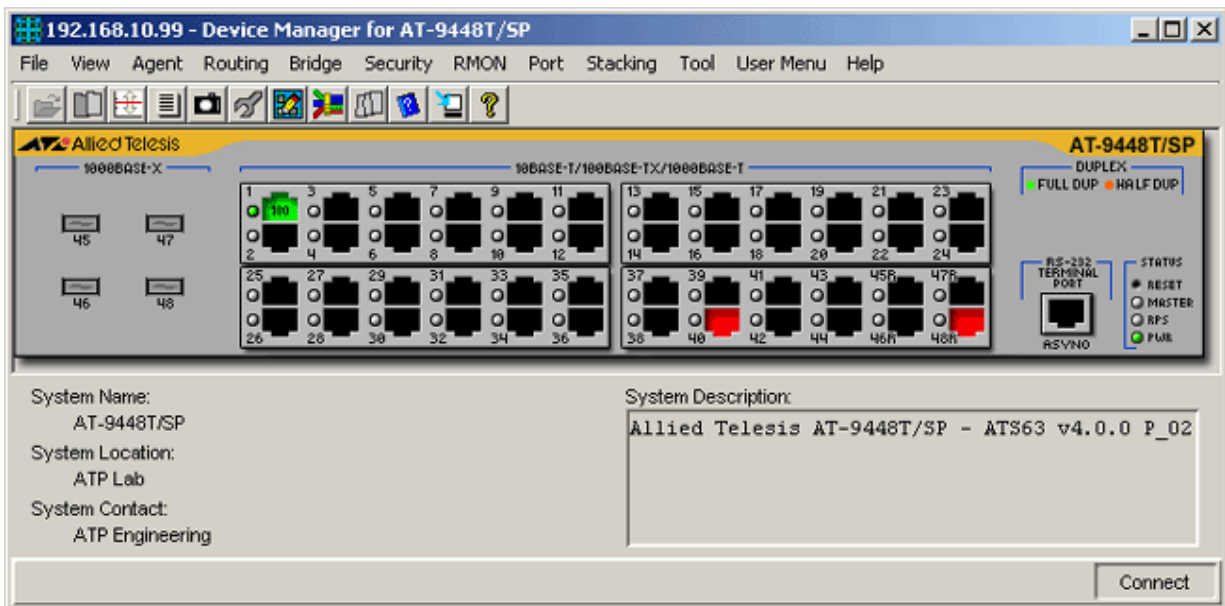

AT-9448T/SP

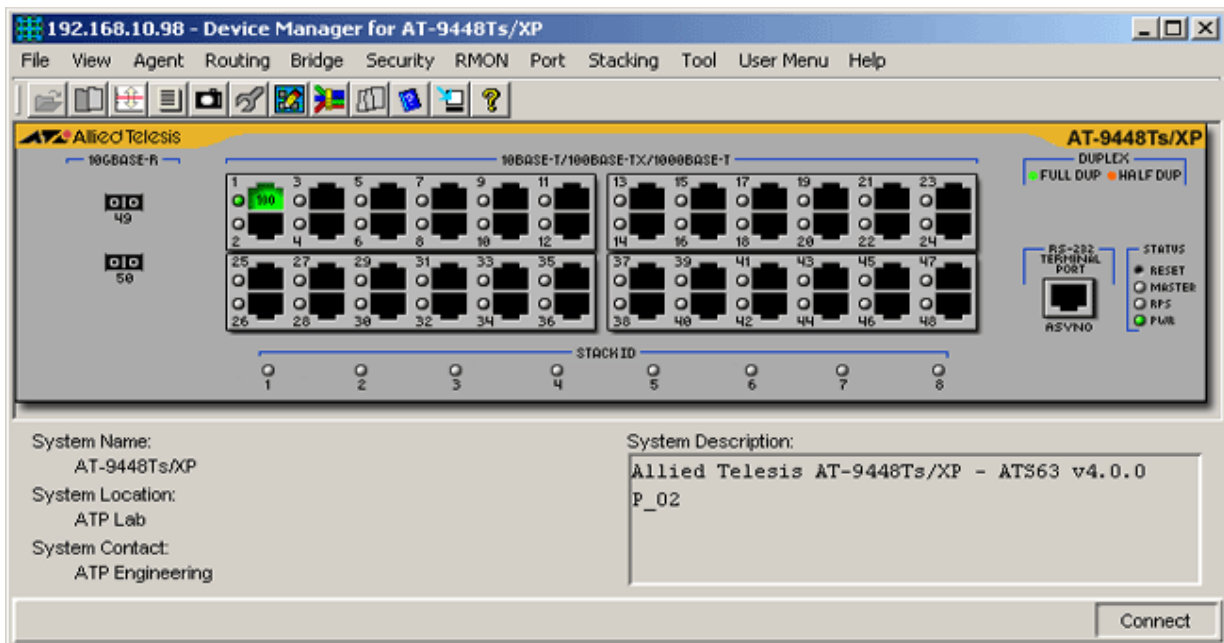

AT-9448Ts/XP

Device Manager LEDs for AT-9400 Series

LED	State	Description
PWR	Green	The switch is receiving power.
MASTER	Orange	The switch is the master switch of an enhanced stack.
	Gray	The switch is a slave switch or is not a member of an enhanced stack.
DUPLIX	Green	The port is operating in full-duplex mode.
	Orange	The port is operating in half-duplex mode.
RPS	Green	An optional redundant power supply is connected to the switch and is turned on.
	Gray	There is no redundant power supply connected to the switch.
	Yellow	An optional redundant power supply is connected to the switch but is turned off.
STACK ID	Orange	The stacked unit is either the Stacking Master or the Backup Master.
	Gray	The switch is set to standalone mode.
	Green	The stacked unit is a slave switch.

Note - Status information for combo ports will always be reflected on both the RJ-45 port images and the GBIC/SFP port images regardless of whether it is the RJ-45 or the GBIC/SFP ports that are actually in operation. However, if Device Manager detects that the established link speed is less than 1 Gbps, only the RJ-45 port images will turn green.

Note - The current firmware version is unable to detect the presence or absence of an XFP module in any of the XFP slots. As a result, the XFP slots on the device image will always show XFP images regardless of whether or not XFP modules are physically present in the slots.

Note - When connecting to a slave switch, Device Manager does not automatically replace the master switch image in the main window with the slave switch image. The same is true when returning to the master switch from the slave switch. To view the updated image, click on the Refresh option under the Agent menu.

Note - Using an SNMP v3 account that has a NO-READ VACM setting, a 'noSuchName' or 'noSuchObject' error may be displayed.

Note - L2+ Models: Blocking ports will appear green instead of yellow when the Spanning Tree Status parameter is set to "enabled" and the Spanning Tree Version parameter is set to "rstp".

Note - L3 Models: Blocking ports will appear green instead of yellow when the Spanning Tree Status parameter is set to "enabled".

Note - L3 Models: Attempting to connect to any slave device via Enhanced Stacking with AT-9448Ts/XP as the master switch will always fail.

Note - L3 Models: The current firmware version does not return the operating state of the power supply used. As a result, the PWR LED on the device image will always be colored green regardless of whether or not the main power supply is off.

Agent Menu

From the Agent menu, you can view and edit the system information for the device, or log into the CLI using Telnet.

System Info

Displays basic system information, including system name, location, contact and description.

Note - L3 Models: The current firmware version allows up to 38 characters for the System Location parameter.

Network Info

Displays network-related information such as the addresses of the default gateway and the agents.

Note - When multiple units of the AT-9400 are stacked together, the current firmware version will always return the value '1' for the Number of Modules parameter.

Device Info

General Info

Displays general information about the switch.

Note - L2+ Models: The current firmware version returns an incorrect value for the RPS Present parameter. If the device is connected to an RPS, the RPS Present parameter returns 'disconnected'. If it is not, it returns 'connected'.

Note - The current firmware version does not return the correct value for the Hardware Version parameter of the following models:

- AT-9408LC/SP
- AT-9424T/GB
- AT-9424T/SP
- AT-9424Ts

Note - AT-9424T & AT-9424T/POE: The current firmware version always returns the value 'on' for the RPS State parameter regardless of its current state.

Uplink Info

Displays uplink information.

Note - AT-94xxTs/XP: The current firmware version does not return the Uplink Info of the XFP port slots with XFP module/s inserted.

Note - AT-9448Ts/XP: When multiple units of the AT-9400 are stacked together, the current firmware version intermittently returns values for non-uplink ports or does not return any values for the Uplink Info parameter.

Temperature Info

Displays temperature information.

Note - This table is applicable to the L2+ models only.

Fan Info

Displays fan information.

Note - This table is applicable to the L2+ models only.

Note - AT-9424T/POE: The current firmware version returns a 'noSuchName' value for the Fan Info parameter.

Voltage Info

Displays voltage information.

Note - This table is applicable to the L2+ models only.

Management Info

General Config

Displays management configuration information about the switch.

Note - The current firmware version returns "???(0)" for the Action parameter.

Note - AT-9408LC/SP: The current firmware version does not allow the Configuration Action parameter to be configured.

Access Lists

Displays management access lists for the switch.

Note - Device Manager does not handle objects of type BITS correctly. As a result, the Application parameter may display any of the following values:

- 00100000 - ping
- 01000000 - web
- 10000000 - telnet
- 11100000 - all

but may not be configured.

Note - The current firmware version does not allow the Device Manager to display the option 'All' for the Application parameter.

Note - L3 Models: The current firmware version does not return any Set Error when configuring the Row Status parameter to 'not in service'.

Date and Time

Displays and configures the current date and time of the device.

MAC Address Table

Displays a list of static MAC addresses configured on the switch.

Note - The MIB (atiStackSwitch.mib - L2+ Models: v2.36 / L3 Models: v3.13) supported by the current firmware version defines the Module ID, Port ID and Port List parameters as "read-write". As a result, Device Manager displays these parameters as configurable objects. However, attempting to configure these parameters will show that the firmware does not accept any value.

Note - The only valid MIB Set value for the Status parameter is "destroy". Attempting to set this parameter to any other value may result in the value being ignored or the error message: "The error occurred with 'Set' operation. Error: bad value."

Note - L3 Models: The current firmware version does not return any Set Error when configuring the Status parameter to 'not in service'.

Reset

Resets the switch.

Telnet

Starts a Telnet connection to the switch.

WEB Browser

Connects to the switch's HTTP server.

Note - L3 Models: Attempting to launch a WEB Browser with network traffic and/or collision detected within the network will cause the device to restart.

Routing Menu

From the Routing menu, you can view and edit information about the switch's routing functions.

IP

ARP Table

Displays the ARP cache on the switch.

Address Table

Displays the list of IP interfaces on the switch.

Route Table

Displays the IP routing table on the switch.

Note - The current firmware version does not allow the Device Manager to display the Destination Network Address parameter on the Edit tab.

Note - L3 Models: The current firmware version returns the value 'NULL' for the Routing Protocol parameter.

IP Statistics

Displays statistics about IP routing, including the number of IP datagrams received.

Note - The current firmware version does not allow the Default TTL parameter to be configured.

UDP

Listener Info

Displays UDP listener information.

UDP Statistics

Displays UDP statistics.

TCP

Connection Info

Displays TCP connection-specific information.

TCP Statistics

Displays TCP statistics.

ICMP Statistics

Displays ICMP statistics.

Bridge Menu

From the Bridge menu, you can view and edit bridge information such as the forwarding database and the spanning tree status.

Forwarding Database

Note - Forwarding Database table entries for aggregated ports do not reflect the correct port number in the Port Number column.

Note - When multiple units of the AT-9400 series are stacked together, the FDB table will only return the FDB entries of the master switch.

Note - L2+ Models: Changes to the Forwarding Database table caused by dynamic network topology/configuration changes will not be reflected unless the device is restarted.

Standard View

Displays the Forwarding Database table as returned by the device.

Enhanced View

Displays the Forwarding Database table on a per port basis. User can select a port or group of ports to view its corresponding Forwarding Database entries.

Discard/Aging Time Info

Displays information about the number of address entries that were learned but discarded because either there was a lack of memory or the entry's aging timer expired.

Spanning Tree Info

Displays spanning tree parameters such as priority and cost.

Note - The current firmware version does not allow the Spanning Tree parameter to be configured when the Spanning Tree Version is set to 'MSTP'.

Statistics

Displays statistics about frames received/transmitted on the switch port.

Basic Bridge Info

Displays basic bridge information.

Bridge Port Info

Displays statistics about frames received/transmitted on the switch port.

Note - L3 Models: The current firmware version returns the value 'NULL' for the Circuit parameter.

Security Menu

From the Security menu, you can view and edit security protocols such as the ACL.

Access Control List

Displays the Access Control List table as returned by the device.

Note - The current firmware version allows up to 31 characters for the Description parameter.

Note - The current firmware version does not allow the Port List parameter to be configured to any valid port number when using an AT-9424Ts, AT-9424Ts/XP and AT-9448Ts/XP device models.

Note - The current firmware version does not return any Set Error for the AT-9424Ts, AT-9424Ts/XP and AT-9448Ts/XP device models when configuring the Port List parameter to null.

Note - L3 Models: The current firmware version does not return any Set Error when configuring the Port List parameter to invalid values.

Note - L3 Models: The current firmware version does not return any Set Error when configuring the Row Status parameter to 'not in service'.

Note - L3 Models: The current firmware version does not return any Set Error when configuring the Classifier List parameter to invalid values.

RMON Menu

From the RMON menu you can view and edit the RMON MIB.

Statistics

Displays traffic statistics in the network segment attached to each port.

Standard

Displays standard port statistics.

Additional Info

Displays additional port statistics.

Note - The current firmware version returns a 'noSuchName' value for the Additional Info parameter when using an SNMP v1 account.

Error

Displays error statistics.

Note - The current firmware version returns a 'noSuchName' value for the Error parameter when using an SNMP v1 account.

History Control Table

Displays the RMON History table.

Note - The current firmware version is unable to provide History Control Table information. As a result, the following error message appears: "Failed to get MIB data."

Alarm Table

Displays the RMON Alarm table.

Event Table

Displays the RMON Event table.

Event Log

Displays the RMON Event log.

Port Menu

From the Port menu, you can view and edit MIB information about the port.

Utilization

Displays the port's utilization information.

Interface Info

Standard

Displays port statistics such as the number of packets received and transmitted on the port, bytes received and transmitted on the port and port status. This table also displays high-capacity port statistics including received and transmitted unicast/multicast/broadcast packets on the port, link up/down trap and port speed.

Note - Valid MIB Set values for the Administration Status parameter are 'up' and 'down'. Attempting to set this parameter to any other value will result in the error message: "The error occurred with 'Set' operation. Error: bad value."

Note - The current firmware version does not allow the Port Alias parameter to be configured.

Note - Use SNMP v2c or v3 to view high capacity (HC) port parameter values.

Note - L3 Models: The current firmware version returns the value 'NULL' for the Specific Media parameter.

Additional Info

Displays port statistics such as the number of frames received and transmitted on the port, bytes received and transmitted on the port and port status.

Note - Use SNMP v2c or v3 to view this table.

Error Statistics

Displays error statistics.

Standard

Displays port error statistics such as error frames and collision frames. It also displays deferred transmissions and ethernet chipset information.

Note - When multiple units of the AT-9400 are stacked together, and the master switch is an AT-9424Ts or an AT-9424Ts/XP, the current firmware version returns incorrect values for the Error Statistics parameter.

Note - L3 Models: The current firmware version returns the value 'NULL' for the Ethernet Chip Set parameter.

Additional Info

Displays Bad Frames Received and Collision parameters.

Note - Use SNMP v2c or v3 to view this table.

Detail Info

Displays detailed port information such as duplex mode.

Note - The Port MDIO parameter is not applicable to the AT-9408LC/SP.

Note - The Port CoS/QoS Priority and Port STP State parameters are not applicable to the AT-9400 series and should be ignored.

Note - Valid MIB Set values for the Port Flow Control and Port Back Pressure parameters are 'disable' and 'enable'. Attempting to set these parameters to 'unknown' will cause them to be set to 'enable'.

Note - Configuring the Port HOL Limit parameter of a slave switch to any value within the range [1-8191] will return a Set Error and will cause the master device to restart.

Note - L3 Models: The current firmware version does not allow the Port Speed and Port Duplex parameters to be configured to the desired port speed and duplex mode. As a result, the speed label that will be displayed on the port image and its corresponding DUP LED will depend on the actual speed and duplex mode detected by the device.

Note - AT-94xxTs/XP: The current firmware version returns the value 'unknown' for the Port Speed parameter of the XFP ports.

Enable

Enables the port.

Disable

Disables the port.

Port Trunking

Displays Port Trunking information as returned by the device and allows the configuration of trunk name, method and port list.

Note - The current firmware version allows the Trunk Name parameter to be configured.

Note - L3 Models: The current firmware version does not return any Set Error when configuring the Row Status parameter to 'not in service'.

Note - L3 Models: The current firmware version does not return any Set Error when configuring the Port List parameter to invalid values.

Port Mirroring

Displays Port Mirroring parameters and allows you to create/delete a port mirror.

Note - The Mirroring Source Module, Mirroring Source Port and Mirroring Destination Module parameters are not applicable to the AT-9400 series and should be ignored.

Note - L2+ Models: The current firmware version does not allow the Mirroring Source Port (Ingress) and Mirroring Source Port (Egress) parameters to be set to NULL.

Note - L3 Models: The current firmware version does not return any Set Error when configuring the Mirroring Source Port (Ingress) and Mirroring Source Port (Egress) parameters to invalid values.

MAC Address Security

Displays MAC Address Security parameters and allows you to set the security level for dynamic and static MAC addresses learned and assigned to a port.

Note - The current firmware version does not allow the Security Mode parameter to be configured to 'automatic', 'limited' or 'locked' when connected to an AT-9424T, AT-9448T/SP or to an AT-9424T/PoE device models.

DoS Defense

Displays DoS Defense parameters and allows you to enable/disable a defense mechanism on a port.

Note - The Attack Mirror Port parameter under each Attack Type option is already obsolete and should be ignored.

Note - The Attack Mirror Port Status parameter is not applicable to the SYN Flood and Smurf defenses and should be ignored.

LAN IP Subnet

Displays LAN IP address and subnet mask

SYN Flood Config

Displays syn flood attack type configuration

Smurf Config

Displays smurf attack type configuration.

Land Config

Displays land attack type configuration

IP Option Config

Displays IP option attack type configuration

Note - L3 Models: The current firmware version does not allow the Attack Action Status parameter to be set to 'enabled'.

Note - L3 Models: The current firmware version does not allow the Attack Mirror Port Status parameter to be set to 'enabled' or 'disabled'.

Teardrop Config

Displays teardrop attack type configuration

Ping Death Config

Displays ping of death attack type configuration

Stacking Menu

From the Stacking menu, you can view physical stack info and you can access slave switches and other Master switches in the enhanced stack.

Stack Info

Displays the number of modules present in the stack.

Enhanced Stacking Info

Displays Enhanced Stacking parameters, allows you to set the switch's enhanced stacking status and select a switch to manage in the enhanced stack.

Note - Attempting to connect to an AT-9424Ts or an AT-9424Ts/XP slave from any master device that supports Enhanced Stacking will result in the error message: "The error occurred with 'Set' operation. Error: gen Error".

Note - Attempting to connect to an AT-8400 slave from an AT-9400 master will result in the error message: "The error occurred with 'Set' operation. Error: gen Error".

Note - Connecting to an AT-9408LC/SP or to an AT-9424T/SP slave from any master device that supports Enhanced Stacking can only be done once. Once the management session is returned to the master device, any attempt to reconnect to these slave devices will fail.

AT-9700 Series

This section describes Device Manager menus and operations specific to the AT-9700 Series of Advanced Layer 3 Gigabit Switches.

Topics:

- Main Window
- Agent Menu
- Routing Menu
- Bridge Menu
- IGMP Menu
- VRRP Menu
- Security Menu
- RMON Menu
- Port Menu

Main Window

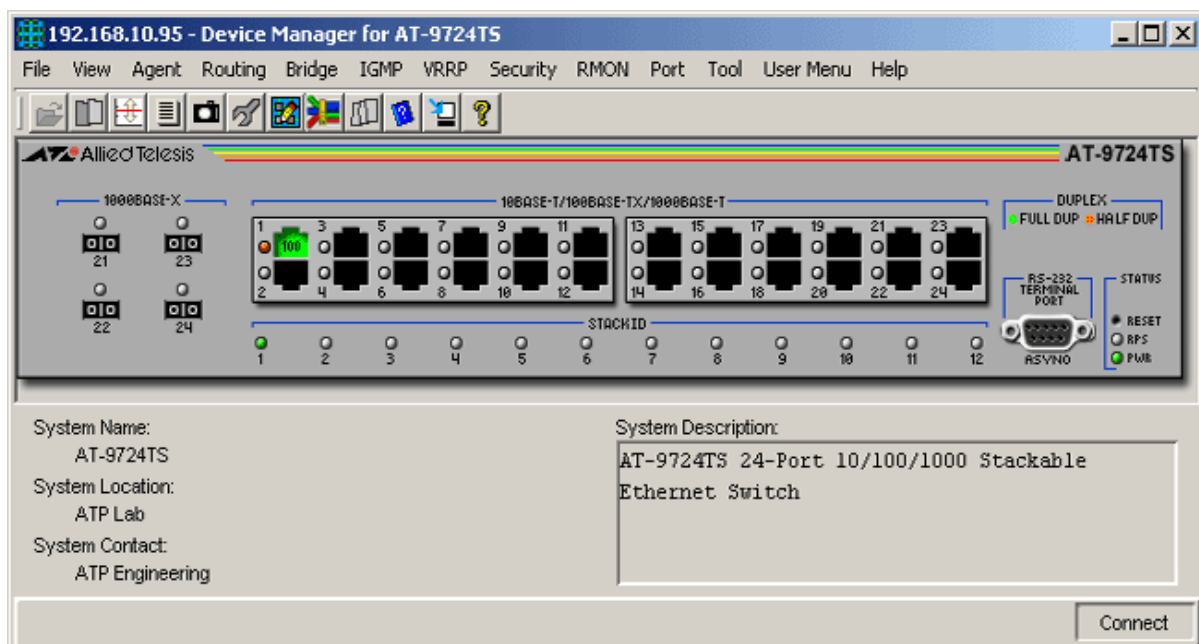

AT-9724TS

The AT-9724TS supports up to 12 stacked AT-9724TS switches.

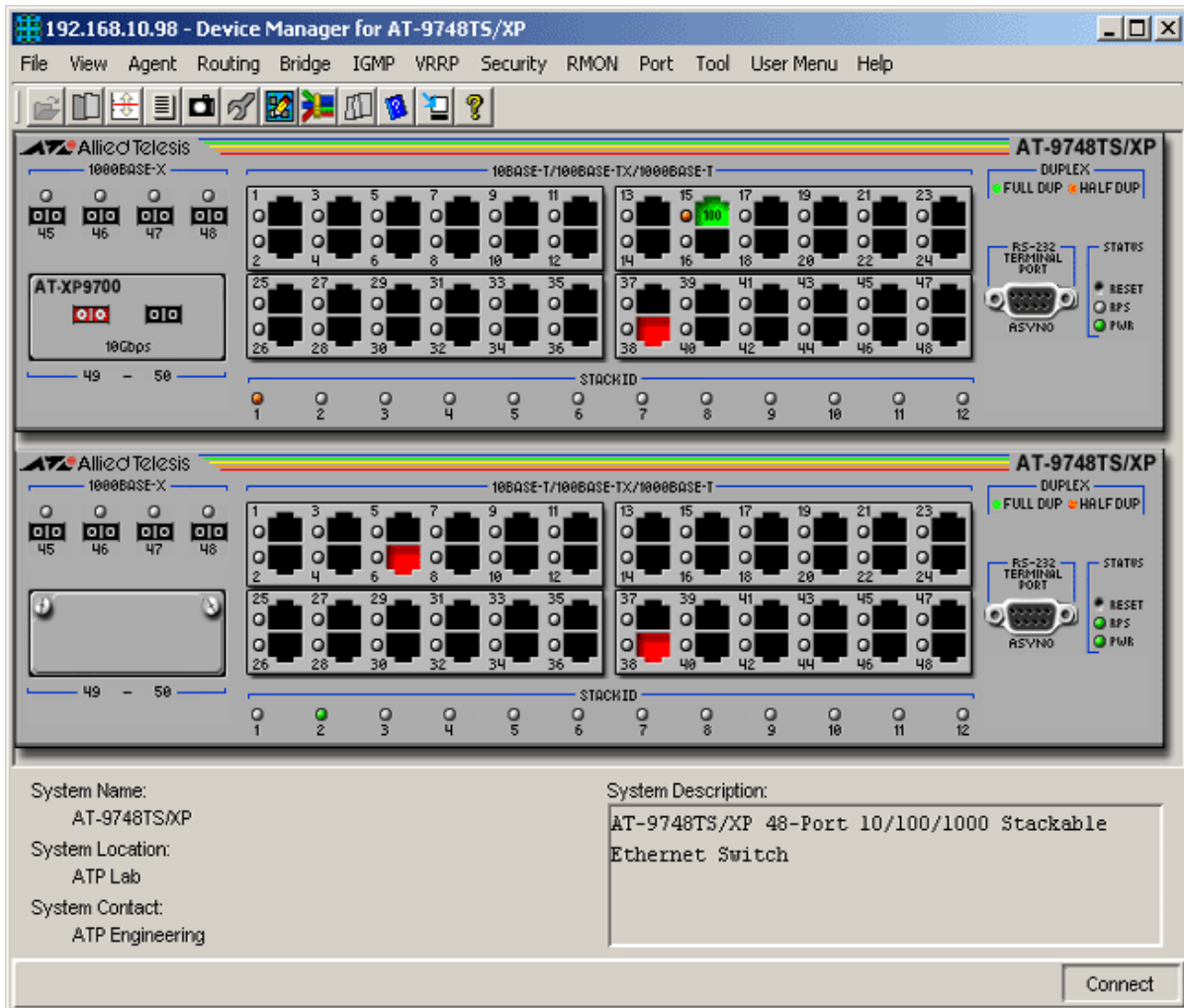

AT-9748TS/XP

The AT-9748TS/XP supports up to 8 AT-9748TS/XP stacked switches with no uplinks or 5 AT-9748TS/XP stacked switches with 10G uplinks or any of the following mixed stack combinations of AT-9748TS/XP and AT-9724TS switches.

AT-9748TS/XP (With 10G Uplink)	AT-9748TS/XP (No Uplink)	AT-9724TS
5	0	≤ 1
4	2	0
4	1	≤ 2
3	2	≤ 3
3	1	≤ 5
3	0	≤ 7
2	5	0
2	4	≤ 2
2	3	≤ 4

AT-9748TS/XP (With 10G Uplink)	AT-9748TS/XP (No Uplink)	AT-9724TS
2	2	<=6
2	1	<=8
2	0	<=10
1	6	<=1
1	5	<=3
1	4	<=5
1	3	<=7
1	2	<=9
1	1	<=10
1	0	<=11
0	7	<=2
0	6	<=4
0	5	<=6
0	4	<=8
0	3	<=9
0	2	<=10
0	1	<=11

Device Manager LEDs for AT-9700 Series		
LED	State	Description
PWR	Green	The switch is receiving power from the main power supply.
RPS	Green	The switch is receiving power from the redundant power supply.
	Gray	RPS is not installed or not functioning.
STACK ID	Green	The stacked unit is either a slave switch or the switch is not in a stacked mode.
	Orange	The stacked unit is the master switch.
DUPLEX	Green	The port is operating in full-duplex mode.
	Orange	The port is operating in half-duplex mode.

Note - The Stack ID LED indicates the Box ID of the stacked switch or standalone switch.

Note - When multiple units of the AT-9700 series are stacked together, port numbering is continuous based on the Box ID.

- Box ID 1 - 1 to 64
- Box ID 2 - 65 to 128
- Box ID 3 - 129 to 192
- Box ID 4 - 193 to 256
- Box ID 5 - 257 to 320
- Box ID 6 - 321 to 384
- Box ID 7 - 385 to 448
- Box ID 8 - 449 to 512
- Box ID 9 - 513 to 576
- Box ID 10 - 577 to 640
- Box ID 11 - 641 to 704
- Box ID 12 - 705 to 768

This numbering scheme assumes that a unit can have a maximum of 64 ports.

Note - The current firmware version does not allow Device Manager to detect the presence or absence of an SFP module in any of the SFP slots. As a result, the SFP slots on the device image will always show SFP images regardless of whether or not SFP modules are physically present in the slots.

Note - Status information for ports 21 to 24 on the AT-9724TS and ports 45 to 48 on the AT-9748TS/XP will always be reflected on both the RJ-45 port images and the SFP port images regardless of whether it is the RJ-45 or the SFP ports that are actually in operation. However, if Device Manager detects that the established link speed is less than 1 Gbps, only the RJ-45 port images will turn green.

Agent Menu

From the Agent menu, you can view and edit the system information for the switch, or log into the CLI using Telnet.

System Info

Displays basic system information, including system name, location, contact and description.

Device Info

Equipment Capacity

Displays the equipment capacity supported in the system.

Power Supply Info

Displays information about the power supply and redundant power supply .

Fan Info

Displays fan status.

Unit Info

Displays information about the system's stacking mode, units supported in the system, total number of ports and number of ports in use.

Unit Management Info

Displays management information for each unit in the system.

Module Info

Displays module information for each unit in the system.

Management Info

General Info

Displays common management information.

General Config

Displays basic control of the system.

Note - The current firmware version does not allow the RS-232C Mode parameter to be configured.

Note - It may take a while for the device to set the STP Status parameter to 'enable'. As a result, a timeout error may occur. However, the value is still set successfully.

MIB List

Displays the list of MIB capability entries supported by the system.

TFTP Services

Displays information about the files that have been downloaded from and uploaded to the device.

Note - The current firmware version does not allow the following parameters to be configured:

- Description
- Transfer Type
- File Type
- File Control
- Download CFG File
- Multi Image Control ID

Note - Valid MIB Set values for the Load Type parameter will depend on the Description parameter:

- boot file - download
- log file - upload
- config file - upload/download

IP Protocol Info

Displays information about the IP interfaces supported by the system.

Multiple Image List

Displays information about multiple image management.

Alarm Config

Displays the status of trap configurations.

Group Management

Group Management Info

Displays the basic information of the device.

Group Management Config

Displays status and role state of the switch in the system.

Note - The current firmware version does not allow the Switch Role parameter to be set to 'member'.

Member Switches

Displays information about member switches that belong to the group management group.

Note - The current firmware version does not allow the Candidate ID and Candidate Password parameters to be configured.

Candidate Switches

Displays information about candidate switches that belong to the group management group.

Groups

Displays information about group management groups learned by the command switch.

Neighbors

Displays information about group management Neighbors.

Date and Time

System Date and Time

Displays the current date and time configuration of the system.

Note - The current firmware version does not allow the Current Clock parameter to be configured.

Summer Date and Time

Displays the summer date and time configuration of the system.

Note - The current firmware version does not allow the following parameters to be configured:

- Repeating Start
- Repeating End
- Annual Start
- Annual End

SNTP

Displays the SNTP configuration of the system.

System Log Server Config

Displays basic information and configuration of the System Log Server.

Reset Cold

Performs a hardware reset.

Reset Warm

Performs a software reset.

Note - This function is currently not supported.

Telnet

Starts a Telnet connection to the switch.

WEB Browser

Connects to the switch's HTTP server.

Routing Menu

From the Routing menu, you can view and edit various routing protocols such as RIP, DVMRP, OSPF, PIM and IPM.

IP

Interface Info

Displays information about IP interfaces.

Note - The current firmware version does not allow the following parameters to be configured:

- Interface Name
- IP Subnet Mask
- VLAN Name
- Operation Mode
- Secondary IP

Forwarding Database

Displays the Forwarding Database table.

ARP Aging Time

Displays the timeout period in minutes for aging out dynamically learned arp information.

Static Route Table

Displays the IP static routing table.

Note - The current firmware version does not allow the Next Hop Address and Destination Metric parameters to be configured.

Note - The only valid MIB Set value for the Entry Status parameter is 'invalid'. Attempting to set this parameter to any other value will result in the error message: "The error occurred with 'Set' operation. Error: noSuchName."

IP Statistics

Displays statistics about IP routing, including the number of IP datagrams received.

UDP

Listener Info

Displays UDP listener information.

UDP Statistics

Displays UDP Statistics.

TCP

Connection Info

Displays TCP connection-specific information.

Note - The current firmware version does not allow the Connection Status parameter to be configured.

TCP Statistics

Displays TCP Statistics.

CIDR

Route Number

Displays the number of valid CIDR entries.

Route Table

Displays the CIDR routing tables.

Note - Only the Row Status parameter can be configured.

ICMP Statistics

Displays ICMP Statistics.

Route Preferences

Displays configurations of routing preferences.

Route Redistribution

Displays the route redistribution table of various protocols.

RIP

Basic Info

Displays basic information about Routing Information Protocol.

Interface Info

Displays the list of subnets which require separate status monitoring in Routing Information Protocol.

Note - The Row Status parameter has a fixed value of 'active' and cannot be modified.

Interface Config

Displays the list of subnets which require separate configuration in Routing Information Protocol.

Note - The current firmware version does not allow the Domain and Default Metric parameters to be configured.

Note - Valid MIB Set values for the Row Status parameter are 'active' and 'not in service'. Attempting to set this parameter to any other value will result in the error message: "The error occurred with 'Set' operation. Error: bad value".

Note - The current firmware version does not allow the following parameters to be configured:

- Domain
- Authentication Key
- Default Metric
- Source IP Address

Active Peer Info

Displays information about active peer relationships.

OSPF

Basic Info

Displays basic information about Open Shortest Path First routing protocol.

Note - The current firmware version does not allow the following parameters to be configured:

- AS Border Router Status
- Type of Service Support Status
- Ext Link State DB Limit
- Multicast Extensions
- Exit Overflow Interval
- Demand Extensions

Area Info

Displays the configured parameters and cumulative statistics of the device's attached areas.

Note - The Authentication Type parameter is not applicable to the AT-9700 Series and should be ignored.

Stub Area Config

Displays the set of metrics that will be advertised by a default Area Border Router into a stub area.

Note - The current firmware version does not allow the Row Status and Metric Type parameters to be configured.

Link State Ads

Displays the OSPF Process' Link State Database.

Note - The Link State Ads sub-menu option does not display the correct parameters. Instead, it displays the sub-menu option name as a parameter with a value of 'noSuchName'.

Host Info

Displays the list of hosts, and their metrics, that the device will advertise as host routes.

Note - The current firmware version does not allow the Metric parameter to be set to 0.

Interface Info

Displays the interfaces from the viewpoint of OSPF.

Note - The current firmware version does not allow the following parameters to be configured:

- Type
- Transit Delay
- Retransmission Interval
- Multicast Forwarding

- Demand
- Authentication Type
- Authentication Key
- Authentication Key ID
- Row Status

Interface Metric

Displays the Type of Service metrics for a non-virtual interface.

Note - The current firmware version does not allow the Value parameter to be set to 0.

Virtual Interface Info

Displays information about this device's virtual interfaces.

Note - The current firmware version does not allow the following parameters to be configured:

- Authentication Type
- Authentication Key
- Authentication Key ID

Neighbor Info

Displays the non-virtual neighbor information.

Note - The Neighbor Info sub-menu option does not display the correct parameters. Instead, it displays the sub-menu option name as a parameter with a value of 'noSuchName'.

Virtual Neighbor Info

Displays the virtual neighbor information.

Note - The Virtual Neighbor Info sub-menu option does not display the correct parameters. Instead, it displays the sub-menu option name as a parameter with a value of 'noSuchName'.

External Link State Ads

Displays the OSPF Process' Link State Database containing only the External Link State Advertisements.

Area Aggregate Info

Displays the range of IP addresses specified by an IP address/IP network mask pair .

DVMRP

Basic Info

Displays basic information about Distance Vector Multicast Routing Protocol.

Interface Info

Displays a list of the device's multicast capable interfaces.

Note - The current firmware version does not return any value for the Interface Index parameter.

Note - The following parameters are not applicable to the AT-9700 Series and should be ignored:

- Remote Address
- Remote Subnet Mask
- Generation ID
- Received Packets
- Transmitted Packets
- Received Octets
- Transmitted Octets

Note - The current firmware version returns 'noSuchName' for the Transmitted Routes, Master Key and Master Key Version parameters.

Note - The current firmware version does not allow the Local Address parameter to be configured.

Neighbor Info

Displays a list of the device's DVMRP neighbors, as discovered by receiving DVMRP messages.

Note - The Neighbor Info sub-menu option does not display the correct parameters. Instead, it displays the sub-menu option name as a parameter with a value of 'noSuchName'.

Route Table

Displays the table of routes learned through DVMRP route exchange.

Next Hop Table

Displays the table containing information on the next hops on outgoing interfaces for routing IP multicast datagrams.

Note - The Next Hop Table sub-menu option does not display the correct parameters. Instead, it displays the sub-menu option name as a parameter with a value of 'noSuchName'.

PIM

Basic Info

Displays the default interval at which periodic PIM-SM Join/Prune messages are to be sent, PIM Parameter Settings, Candidate - Rendezvous Point Global Settings, and Candidate - BSR Settings.

Note - The current firmware version returns 'noSuchName' for the Join/Prune Interval parameter and does not allow it to be configured.

Note - Valid MIB set values for the Register Probe Time parameter are in the range [0-127] inclusive.

Note - Valid MIB set values for the Register Suppression Time parameter are in the range [1-255] inclusive.

Interface Info

Displays the list of device's Protocol Independent Multicast interfaces.

DR Priority

Displays the DR Priority of the router's interface.

Neighbor Info

Displays a list of the device's PIM neighbors.

Note - The current firmware version returns 'noSuchName' for the Mode parameter.

Route Table

Displays the table of routes learned through PIM route exchange.

Note - The Route Table sub-menu option does not display the correct parameters. Instead, it displays the sub-menu option name as a parameter with a value of 'noSuchName'.

Next Hop Table

Displays the table containing information on the next hops on outgoing interfaces for routing IP multicast datagrams.

Note - The Next Hop Table sub-menu option does not display the correct parameters. Instead, it displays the sub-menu option name as a parameter with a value of 'noSuchName'.

Rendezvous Points

Displays the list of PIM information for candidate Rendezvous Points for IP multicast groups.

Note - The Rendezvous Points sub-menu option does not display the correct parameters. Instead, it displays the sub-menu option name as a parameter with a value of 'noSuchName'.

Candidate - RP

Displays the list of IP multicast groups for which the local router is to advertise itself as a Candidate-RP

Component

Displays the list of objects specific to a PIM.

Note - The Component sub-menu option does not display the correct parameters. Instead, it displays the sub-menu option name as a parameter with a value of 'noSuchName'.

Candidate - BSR

Displays the Candidate - Boot Strap Router configuration.

Register Checksum

Displays the Register Checksum including Data RP List settings.

Static RP

Displays the Static RP settings configured in the router.

Note - The current firmware version does not allow the RP Address parameter to be configured.

Note - The current firmware version returns an incorrect value for the RP Address and Row Status parameters whenever the Get MIB Value button is used.

IPM

Basic Info

Displays basic information about IP Multicast Routing Protocol.

Interface Info

Displays the list of multicast routing information specific to interfaces.

Note - The current firmware version returns 'noSuchName' for the following parameters:

- Rate Limit
- Received Multicast Octets
- Transmitted Multicast Octets
- Received Multicast Octets (HC)
- Transmitted Multicast Octets (HC).

Note - The current firmware version does not allow the Datagram TTL Threshold parameter to be configured.

Scope Name Info

Displays the list of multicast scope names.

Note - The Scope Name Info sub-menu option does not display the correct parameters. Instead, it displays the sub-menu option name as a parameter with a value of 'noSuchName'.

Scope Boundary Info

Displays a list of the device's scoped multicast address boundaries.

Note - The Scope Boundary Info sub-menu option does not display the correct parameters. Instead, it displays the sub-menu option name as a parameter with a value of 'noSuchName'.

Route Table

Displays the table containing multicast routing information for IP datagrams sent by particular sources to the IP multicast groups known to this device.

Note - The Route Table sub-menu option does not display the correct parameters. Instead, it displays the sub-menu option name as a parameter with a value of 'noSuchName'.

Next Hop Table

Displays the table containing information on the next hops on outgoing interfaces for routing IP multicast datagrams.

Note - The Next Hop Table sub-menu option does not display the correct parameters. Instead, it displays the sub-menu option name as a parameter with a value of 'noSuchName'.

BOOTP Relay

Basic Info

Displays basic information about the BOOTP relay function.

Note - Valid MIB set values for the Hop Count parameter are in the range [0-16] inclusive.

Interface Info

Displays information about a specific IP address as a destination to forward BOOTP packets to.

DNS Relay

Basic Info

Displays basic information about the DNS relay function.

Interface Info

Displays the current DNS relay static.

MD5 Key Config

Displays the current MD5 key table.

Note - To configure the MD5 Key parameter, the Row Status parameter must first be set to 'create and go'. Once the MD5 Key parameter has been configured, the Row Status parameter is automatically set to 'active'.

Note - If the MD5 Key parameter is set to a new value whose length is shorter than the length of the previously active MD5 Key, an extra character, as well as the remaining characters of the previous key, is appended to the new value.

Bridge Menu

From the Bridge menu, you can view and edit bridge information such as the forwarding database, discard/aging time information, spanning tree status and 802.1p.

Forwarding Database

Note - A user account assigned a MIB view that excludes a row or multiple rows from the Forwarding Database table will not be allowed to view the table at all.

Standard View

Displays the Forwarding Database table as returned by the device.

Enhanced View

Displays the Forwarding Database table on a per port basis. User can select a port or group of ports to view its corresponding Forwarding Database entries.

Discard/Aging Time Info

Displays information about the number of address entries that were learned but discarded because either there was a lack of memory or the entry's aging timer expired.

Spanning Tree Info

STP Global Settings

Displays spanning tree parameters such as status and version.

MSTP Instance Info

Displays information about the Multiple Spanning Tree Protocol instance.

Note - The current firmware version does not allow the following parameters to be configured:

- VLAN Range List 1 - 64
- VLAN Range List 65 - 128
- VLAN Range List 129 - 192
- VLAN Range List 193 - 256
- VLAN Range List 257 - 320
- VLAN Range List 321 - 384
- VLAN Range List 385 - 448
- VLAN Range List 449 - 512
- Row Status

Statistics

Displays statistics about frames received/transmitted on the switch port.

High Capacity Ports

Displays statistics about frames received/transmitted on high capacity ports.

Note - The current firmware version returns 'noSuchName' for the Received Frames, Transmitted Frames and Discarded Frames parameters.

Overflow Counters

Displays statistics for the high capacity interfaces of a transparent bridge.

802.1p

Config

Displays information on 802.1p such as Device Capabilities, GMRP Status and if Traffic classes are enabled.

Note - The current firmware version returns 'noSuchName' for the GMRP Status parameter.

Port Capabilities

Displays port capabilities associated with this bridge.

GMRP

Displays the list of GARP Multicast Registration Protocol control and status information for every bridge port.

Note - The current firmware version returns 'noSuchName' for the GMRP Status, Failed Registrations and Last PDU Origin parameters.

GARP

Displays Generic Attribute Registration Protocol control for a bridge port.

Note - The current firmware version does not allow the Join Time, Leave Time and Leave All Time to be configured.

IGMP Menu

From the IGMP menu, you can view and edit IGMP information such as IGMP queries and reports sent between devices, VLAN's IGMP functions and interfaces on which IGMP is enabled.

IGMP Config

Displays configurations of the Internet Group Management Protocol function.

Note - IGMP Config parameters cannot be configured when the Row Status parameter under IGMP -> MGMT Management -> Router Interface Info is set to 'active'.

VLAN Info

Displays VLAN parameters such as the maximum supported VLANs and maximum group number per VLAN.

Query Info

Displays IGMP parameters such as the current IGMP query packets which is captured by this device, as well as the IGMP query packets sent by the device.

Group Info

Displays current information which is captured by the device provided that IGMP Snooping and IGMP Status of associated VLAN entry are all enabled.

MGMD Management

Router Interface Info

Displays the list of interfaces on which IGMP is enabled.

Note - The current firmware version accepts values in the range [0-255] inclusive for the Query Maximum Response Time and Last Member Query Interval parameters. However, if the value entered is not a multiple of 10, the firmware will convert it to the largest multiple of 10 less than the entered value. Values less than 10 but greater than 0 will be converted to 10.

Router Cache Info

Displays the list of IP multicast groups for which there are members on a particular interface.

Note - The Router Cache Info sub-menu option does not display the correct parameters. Instead, it displays the sub-menu option name as a parameter with a value of 'noSuchName'.

VRRP Menu

From the VRRP menu, you can view and edit VRRP-related information such as the current VRRP version, VRRP status, VRRP statistics and IP addresses associated with VRRP.

Basic Info

Displays basic information such as the particular version of the Virtual Routing Redundancy Protocol supported by the device and the whether the VRRP-enabled router will generate SNMP traps.

Note - The current firmware version returns 'noSuchName' for the Trap Packet IP Address and Trap Authentication Error Type parameters.

Operations

Displays the table containing statistics information about a given virtual router.

Note - The current firmware version does not allow the Primary IP Address and Authentication Key parameters to be configured.

Note - The current firmware version does not allow the Priority parameter to be configured when the Virtual IP Address (VRRP -> Associated IP Addresses) and the Master IP Address (VRRP -> Operations) values are the same.

Associated IP Addresses

Displays the table of addresses associated with this virtual router.

Statistics

Displays the total number of VRRP packets received with an invalid VRRP checksum value, with an unknown or unsupported version number and with an invalid VRID for this virtual router.

Security Menu

From the Security menu, you can view and edit different security and authentication protocols SSL, SSH, AAC, ACL, port-based and MAC-based authentication.

Authentication Info

Displays authentication information such as the Port Access Control status, authentication protocol used to authenticate user and authentication mode of the device.

Port-based Authentication

PAE Port Info

Displays the system level information for each port supported by the Port Access Entity.

Note - The current firmware version returns 'noSuchName' for the Port Number parameter.

Note - The current firmware version does not allow the Initialize and Re-authenticate parameters to be configured.

Authenticator PAE Info

Displays configuration objects for the Authenticator PAE associated with each port.

Note - The current firmware version returns 'noSuchName' for the Port Number parameter.

Note - The current firmware version does not allow the Key Transmission Status parameter to be configured.

Authenticator PAE Statistics

Displays statistics objects for the Authenticator PAE associated with each port.

Note - The current firmware version returns 'noSuchName' for the Port Number parameter.

Authenticator PAE Diagnostics

Displays diagnostics objects for the Authenticator PAE associated with each port.

Note - The current firmware version returns 'noSuchName' for the Port Number parameter.

Authenticator PAE Session Statistics

Displays session statistics objects for the Authenticator PAE associated with each port.

Note - The current firmware version returns 'noSuchName' for the Port Number, Received Octets and Transmitted Octets parameters.

Supplicant PAE Info

Displays configuration objects for the Supplicant PAE associated with each port.

Note - The current firmware version returns 'noSuchName' for all parameters under this sub-menu option.

Supplicant PAE Statistics

Displays statistics objects for the Supplicant PAE associated with each port.

Note - The current firmware version returns 'noSuchName' for all parameters under this sub-menu option.

MAC-based Authentication

Authenticator PAE Info

Displays status objects for the Authenticator PAE associated with each virtual port (MAC).

Note - The Authenticator PAE Info sub-menu option does not display the correct parameters. Instead, it displays the sub-menu option name as a parameter with a value of 'noSuchName'.

Authenticator PAE Statistics

Displays statistics objects for the Authenticator PAE associated with each MAC address.

Note - The Authenticator PAE Statistics sub-menu option does not display the correct parameters. Instead, it displays the sub-menu option name as a parameter with a value of 'noSuchName'.

Authenticator PAE Diagnostics

Displays diagnostics objects for the Authenticator PAE associated with each MAC address.

Note - The Authenticator PAE Diagnostics sub-menu option does not display the correct parameters. Instead, it displays the sub-menu option name as a parameter with a value of 'noSuchName'.

Authenticator PAE Session Statistics

Displays session statistics objects for the Authenticator PAE associated with each MAC address.

Note - The Authenticator PAE Session Statistics sub-menu option does not display the correct parameters. Instead, it displays the sub-menu option name as a parameter with a value of 'noSuchName'.

RADIUS

RADIUS Server Info

Displays the IP address, UDP port number for authentication and accounting request, and current status of the RADIUS server.

Authentication Client Info

Displays the number of RADIUS Access-Response packets received from unknown addresses and the identifier of the RADIUS authentication client.

Authentication Server Info

Displays the list of RADIUS authentication servers with which the client shares a secret.

Accounting Client Info

Displays the number of RADIUS Access-Response packets received from unknown addresses and the identifier of the RADIUS accounting client.

Accounting Server Info

Displays the list of RADIUS accounting servers with which the client shares a secret.

Secure Shell

SSH Config

Displays basic information and control for Secure Shell management.

Encryption Algorithm

Displays the status of various encryption algorithm such as TDES, Blowfish, AES128, AES192, AES256, Arcfour, CAST128, Twofish128, Twofish192, and Twofish256.

Authentication Mode

Displays the status of various authentication method such as password authentication, Public Key authentication, and Host Key authentication.

Data Integrity Algorithm

Displays the status of the HMAC-SHA1 and HMAC-MD5 data integrity algorithms.

Public Key Algorithm

Displays the status of the RSA and DSA public key algorithms.

Secure Socket Layer

SSL Config

Displays the status of SSL support and cipher suites, and the cache timeout value for the SSL module to refresh the session resume data kept in the database.

Note - The current firmware version does not allow the Cipher Suites parameter to be configured.

Certificate File

Displays the parameters used in downloading certificate or key files.

Access Authentication Control

Basic Info

Displays the maximum number of Login method lists, Enable method lists, Server Groups and AAC servers supported by the system.

Login Method Lists

Displays information about Login authentication method lists.

Note - For user-defined lists, the only valid MIB Set value for the Row Status parameter is 'destroy'. Attempting to set this parameter to any other value will result in the error message: "The error occurred with 'Set' operation. Error: bad value."

Enable Method Lists

Displays information about Enable authentication method lists.

Note - For user-defined lists, the only valid MIB Set value for the Row Status parameter is 'destroy'. Attempting to set this parameter to any other value will result in the error message: "The error occurred with 'Set' operation. Error: bad value."

Application Authentication Settings

Displays various applications that can be used to execute authentication such as console, telnet, HTTP and SSH.

Server Group Info

Displays information about server groups.

Note - For user-defined server groups, the only valid MIB Set value for the Row Status parameter is 'destroy'. Attempting to set this parameter to any other value will result in the error message: "The error occurred with 'Set' operation. Error: bad value."

Server Info

Displays information about servers.

Note - The current firmware version does not allow the Authentication Key parameter to be configured.

Note - The only valid MIB Set value for the Row Status parameter is 'destroy'. Attempting to set this parameter to any other value will result in the error message: "The error occurred with 'Set' operation. Error: bad value."

Access Control List

Ethernet Info

Displays ACL mask of Ethernet information.

Note - The current firmware version does not allow the following parameters to be configured:

- Filtered Ports
- Source MAC Address Mask
- Destination MAC Address Mask

Ethernet Rule

Displays ACL rule of Ethernet information.

Note - The current firmware version does not allow the following parameters to be configured:

- VLAN
- Source MAC Address
- Destination MAC Address
- Ethernet Type

IP Info

Displays ACL mask of IP information.

Note - The current firmware version does not allow the following parameters to be configured:

- Filtered Ports
- TCP/UDP Source Port Mask
- TCP/UDP Destination Port Mask
- Protocol ID Mask

IP Rule

Displays ACL rule of IP information.

Note - The current firmware version does not allow the VLAN and User Mask parameters to be configured.

Packet Content Info

Displays ACL mask of user-defined information.

Note - The current firmware version does not allow the following parameters to be configured:

- Filtered Ports
- Offset 0 to 15
- Offset 16 to 31
- Offset 32 to 47
- Offset 48 to 63
- Offset 64 to 79

Packet Content Rule

Displays ACL rule of user-defined information.

Note - The current firmware version does not allow the following parameters to be configured:

- Offset 0 to 15
- Offset 16 to 31
- Offset 32 to 47
- Offset 48 to 63
- Offset 64 to 79

RMON Menu

From the RMON menu you can view and edit the RMON MIB.

Statistics

Displays traffic statistics in the network segment attached to each port.

History Control Table

Displays the RMON History table.

Alarm Table

Displays the RMON Alarm table.

Event Table

Displays the RMON Event table.

Event Log

Displays the RMON Event log.

Probe

Probe Config

Displays RMON probe information.

Note - The current firmware version returns 'noSuchName' for the Date and Time parameter.

Network Interface Config

Displays configuration parameters for a particular network interface on this device.

Note - Valid MIB Set values for the Row Status parameter are 'active' and 'not in service'. Attempting to set this parameter to any other value will result in error message: "The error occurred with 'Set' operation. Error: bad value".

Port Menu

From the Port menu, you can view and edit MIB information about selected ports.

Utilization

Displays the port's utilization information.

Interface Info

Displays port statistics such as the number of frames received and transmitted on the port, bytes received and transmitted on the port, and port status.

Note - The current firmware version returns '???' (117) for the Port Type parameter.

Note - The current firmware version returns the value 0.0 for the Specific Media MIB parameter which Device Manager interprets as a null value.

Error Statistics

Displays error statistics for the port.

Note - The current firmware version returns the value 0.0 for the Ethernet Chip Set parameter which Device Manager interprets as a null value.

Detail Info

Port Info

Displays detailed port information such as port type, port link state and port speed and duplex status.

Port Config

Displays configuration parameters for a particular port such as administration status and port speed and mode.

Note - The current firmware version does not allow the Port Speed and Mode parameter to be set to 'other'.

Note - The Port Flow Control parameter is not applicable to the 10Gbps ports on the AT-XP9700 expansion module.

Spanning Tree Info

STP

Displays information maintained by every port about the Spanning Tree Protocol.

Note - The current firmware version does not allow the Administrative Hello Time and Migration parameters to be configured.

MSTP

Displays information maintained by every port about the Multiple Spanning Tree Protocol.

Enable

Enables the port.

Disable

Disables the port.

Port Security

Config

Displays port security configuration parameters for every port present in the switch.

Deletion

Displays configuration parameters to allow port security deletion.

Note - The current firmware version does not allow the MAC Address and Port Security Deletion Activity parameters to be configured.

Traffic Management

Config

Displays traffic control configuration parameters for every port present in the switch.

Segmentation

Displays the information that specifies the port with its traffic forward list.

Note - The current firmware version does not allow the Forward Ports parameter to be configured.

Port Mirroring

Displays port mirroring parameters and allows configuration of port mirroring status, destination port, Ingress source port and Egress source port.

Note - The current firmware version does not allow the Mirroring Source Port (Ingress) and Mirroring Source Port (Egress) parameters to be configured.

QoS

Basic Config

Displays QoS parameters and allows enabling of Hol prevention status and setting of scheduling mechanism.

Scheduling Mechanism

Displays scheduling mechanism parameters.

802.Ip Default Priority

Displays the 802.Ip default priority table..

802.Ip User Priority

Displays the 802.Ip user priority class table.

User Priority Regeneration

Displays the regenerated user priorities table.

Traffic Class

Displays the traffic class table.

Outbound Access Priority

Displays the outbound access priority table.

Bandwidth Control

Displays the bandwidth control table.

Note - Valid MIB Set values for the Receive Rate and Transmit Rate parameters are in the range [1-10000] inclusive. However, specifying a value greater than 999 will automatically set these parameters to 999.

Port Trunking

Basic Info

Displays basic information about port trunking.

Trunk Config

Displays port trunking parameteres and allows configuration of the master port, member ports, trunk type and trunk status.

Note - The current firmware version does not allow the Member Ports and Trunk Type parameters to be configured.

Aggregator Info

Displays information about every Aggregator that is associated with this system.

Note - The current firmware version returns 'noSuchName' for the Aggregate Index parameter.

Note - The current firmware version does not allow the Actor System Priority and Collector Maximum Delay parameters to be configured.

Aggregator Port List

Displays Link Aggregation Control information for every Aggregation Port associated with this device.

Note - The current firmware version returns 'noSuchName' for the Port Number parameter.

Note - The current firmware version does not allow the following parameters to be configured:

- Actor System Priority
- Actor Operational Key
- Partner Administrative System Priority
- Partner Administrative System ID
- Actor Port Priority
- Partner Administrative Port
- Partner Administrative Port Priority

Note - Setting the Actor Administrative Status parameter and the Partner Administrative Status parameter to 'lACPActivity' or 'lACPTimeout' will result in the same hex value of '6C'. On the other hand, setting them to 'distributing' or 'defaulted' will result in the same hex value of '64'.

LACP Statistics

Displays Link Aggregation information for every port that is associated with this device.

Note - The current firmware version returns 'noSuchName' for all parameters under this sub-menu option.

LACP Debug

Displays Link Aggregation debug information for every port that is associated with this device.

Note - The current firmware version returns 'noSuchName' for all parameters under this sub-menu option.

Expansion Module Notes

- The current firmware version does not allow Device Manager to detect the presence or absence of an XFP transceiver in any of the expansion module's XFP slots. As a result, the XFP slots on the device image will always show XFP images regardless of whether or not XFP transceivers are physically present in the slots.

AT-9700 Series

AT-9800 Series

This section describes Device Manager menus and operations specific to the AT-9800 Series of Multi-Layer Gigabit Switches.

Topics:

- Main Window
- Agent Menu
- Routing Menu
- Bridge Menu
- Port Menu

Main Window

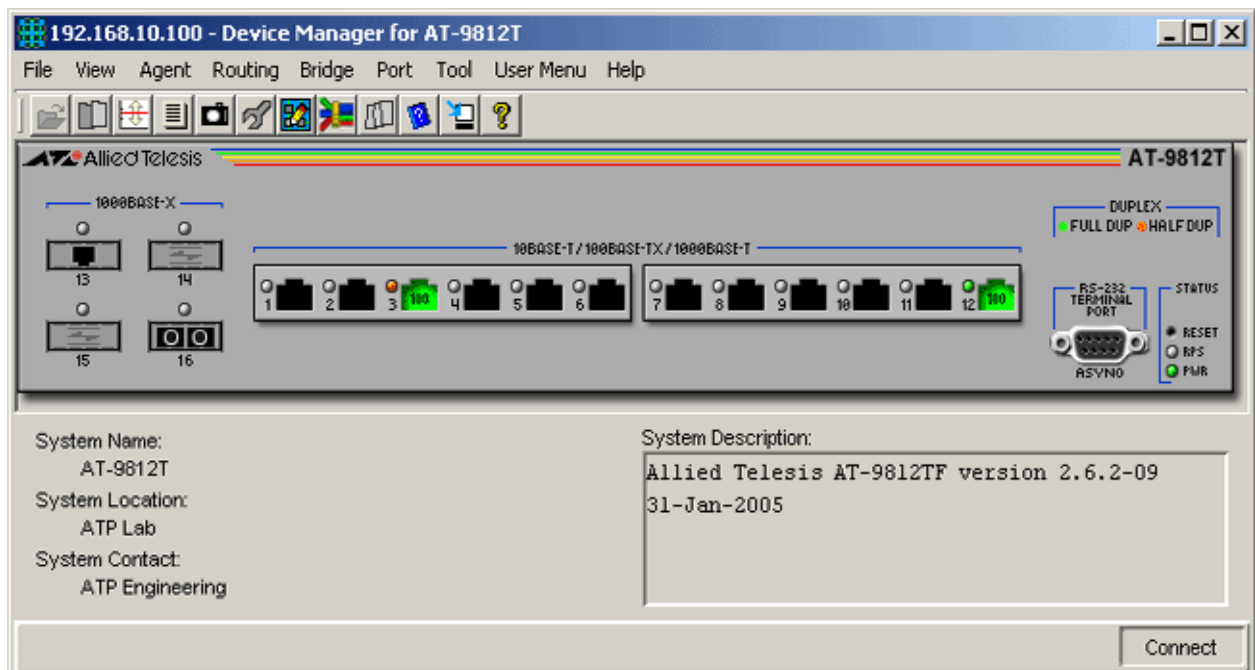

AT-9812T

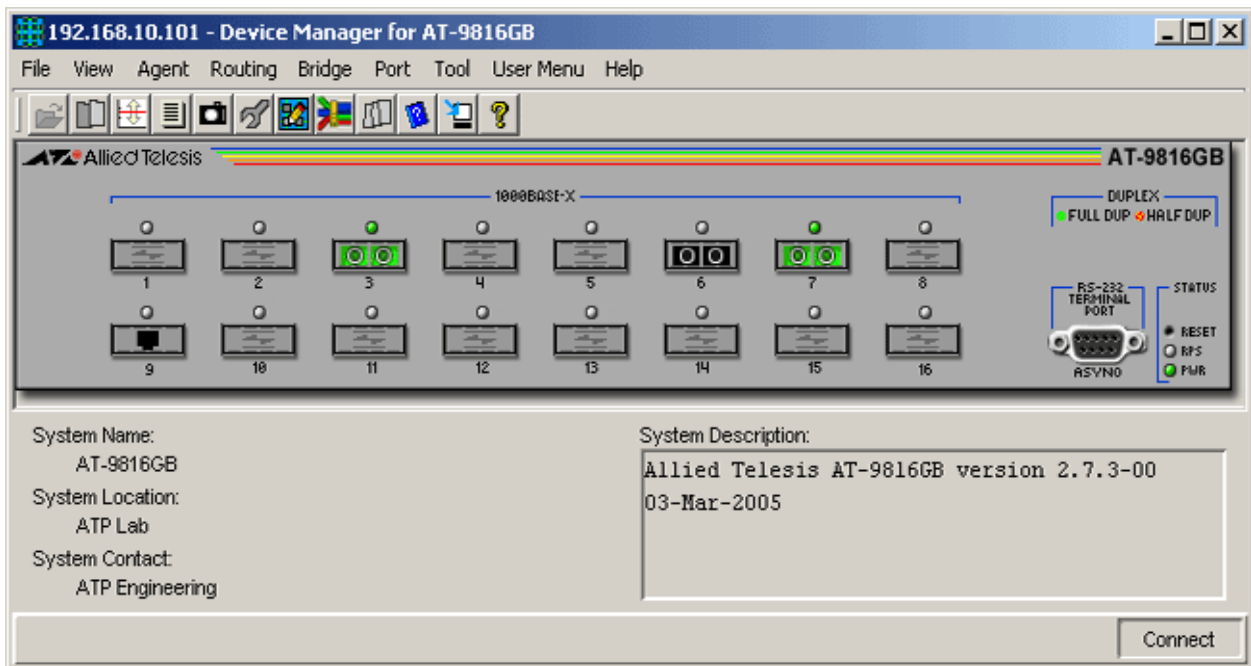

AT-9816GB

Device Manager LEDs for AT-9800 Series		
LED	State	Description
PWR	Green	The switch is receiving power from the main power supply.
	Red	Main power supply is either off or has failed.
RPS	Green	The switch is receiving power from the redundant power supply.
	Red	RPS has failed.
	Gray	RPS is not installed or RPS monitoring is disabled.
DUPLEX	Green	The port is operating at full duplex.
	Orange	The port is operating at half duplex.

Note - AT-9812T, AT-9812TF and AT-9812T-DC share the same device image.

Note - AT-9816GB, AT-9816GF and AT-9816GB-DC share the same device image.

Note - To turn RPS monitoring on or off on the switch, enter the command `SET SYSTEM RPSMONITOR={ON|OFF}` from the command line interface. To see whether RPS monitoring is on, use the command `SHOW SYSTEM`. To turn on RPS monitoring using SNMP, set the `fanAndPsRpsMonitoringStatus` variable to on.

Note - The current firmware version does not allow Device Manager to support the RPS LED on the DC models.

Agent Menu

From the Agent menu, you can view and edit the system information for the switch, or log into the CLI using Telnet.

System Info

Displays basic system information, including system name, location, contact and description.

Power Supply Info

Displays information about the power supply, redundant power supply and power supply monitoring.

Firmware Info

Displays a list of software releases installed on the switch.

File List

Displays a list of the files in the switch's file system.

Config File Name

Displays the file name of the start-up configuration file.

Chassis Temperature Info

Displays the actual temperature of the switch and the temperature status.

Telnet

Starts a Telnet connection to the switch.

WEB Browser

Opens your web browser and connects to the switch's HTTP server.

Note - The web browser can only contact the device if the device has a valid resource file loaded and set, and the HTTP server and GUI on the device are enabled.

Reset Cold

Resets the hardware and executes the default configuration file.

Reset Warm

Performs a warm start of the software modules and executes the default configuration file.

Routing Menu

From the Routing menu, you can view and edit information about the switch's IP routing functions.

ARP Table

Displays the mapping of IP addresses to MAC addresses (the ARP cache), on the switch.

Address Table

Displays the list of IP interfaces and their IP addresses on the switch.

Route Table

Displays the IP routing table on the switch.

IP Statistics

Displays statistics about IP routing, including the number of IP datagrams received.

ICMP Statistics

Displays statistics about ICMP, including the number of ICMP datagrams received.

Bridge Menu

From the Bridge menu, you can view and edit bridge information such as the forwarding database and the spanning tree status.

Forwarding Database

Standard View

Displays the Forwarding Database table as returned by the device.

Enhanced View

Displays the Forwarding Database table on a per port basis. User can select a port or group of ports to view its corresponding Forwarding Database entries.

Discard/Aging Time Info

Displays information about the number of address entries that were learned but discarded because either there was a lack of memory or the entry's aging timer expired.

Spanning Tree Info

Displays spanning tree parameters such as priority and cost.

Statistics

Displays statistics about frames received/transmitted on the switch port.

Port Menu

From the Port menu, you can view and edit MIB information about the port.

Utilization

Displays the port's utilization information.

Interface Info

Displays port statistics such as the number of frames received and transmitted on the port, bytes received and transmitted on the port, and port status.

Error Statistics

Displays error statistics.

Spanning Tree Info

Displays the port's spanning tree parameters.

MAU Info

Displays interface-related MAU information for the port.

MAU Negotiation Info

Displays the MAU's auto-negotiation settings and its status.

Enable

Enables the port.

Disable

Disables the port.

AT-9900/AT-9900s Series

This section describes Device Manager menus and operations specific to the AT-9924T, AT-9924SP, AT-9924T/4SP and AT-9924Ts Advanced Layer 3 Gigabit Switches.

Topics:

- Main Window
- Agent Menu
- Routing Menu
- Bridge Menu
- Port Menu

Main Window

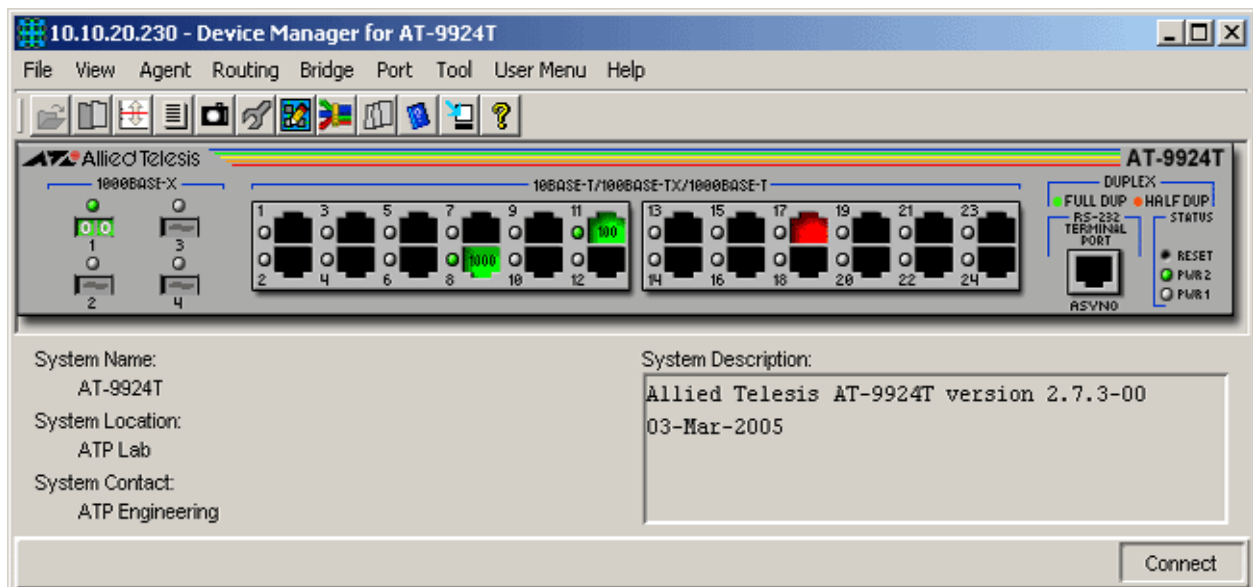

AT-9924T

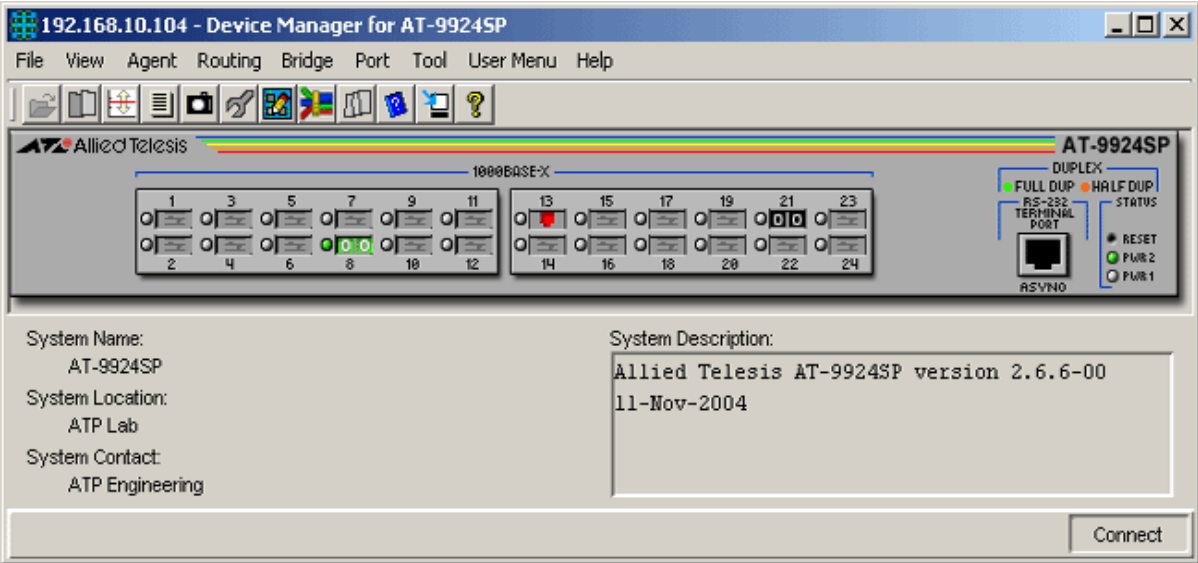

AT-9924SP

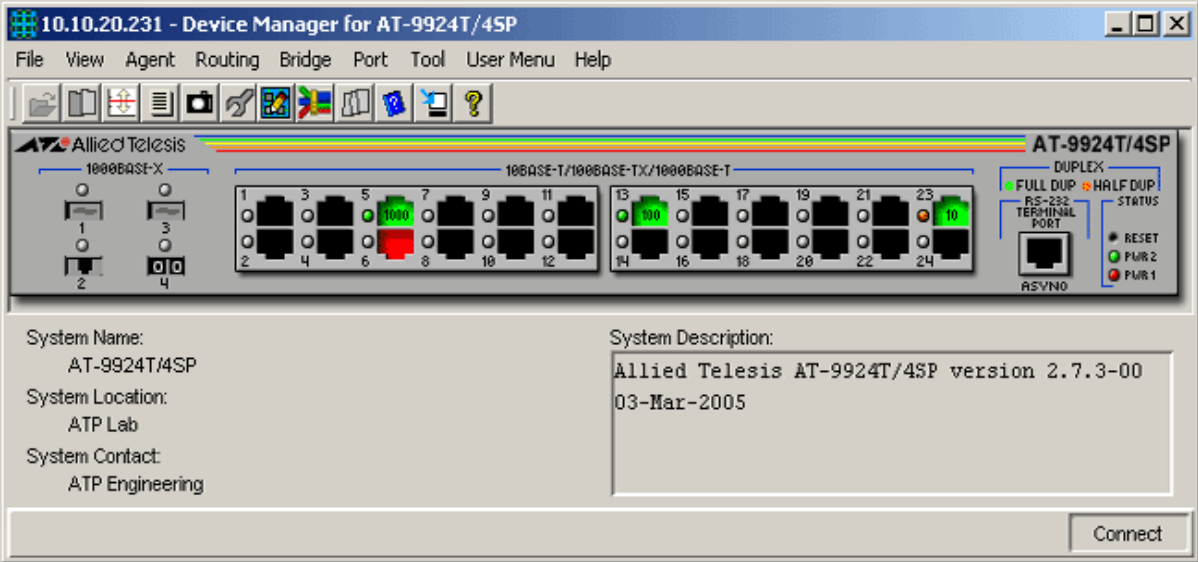

AT-9924T/4SP

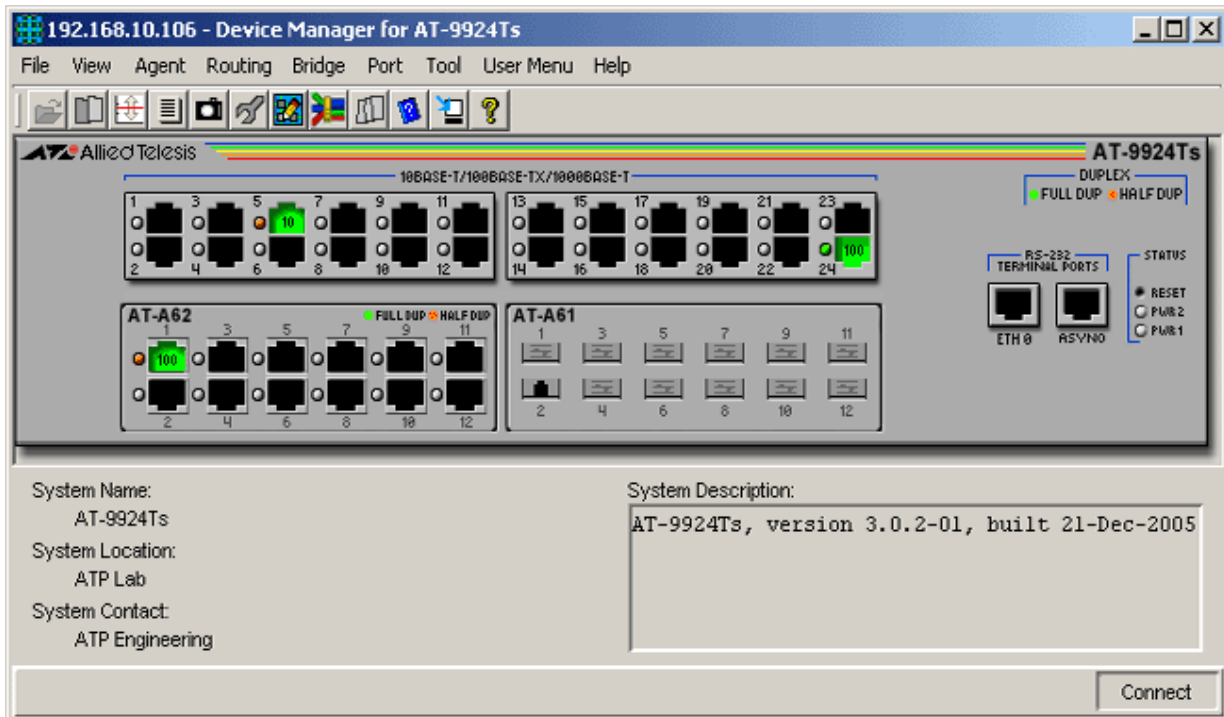

AT-9924Ts

Device Manager LEDs for AT-9900/AT-9900s Series		
LED	State	Description
PWR 1 and PWR 2	Green	There is a power supply unit (PSU) in the PSU bay, and it is supplying power to the switch.
	Gray	There is a functioning Fan Only Module (FOM) in the PSU bay.
	Red	Either: <ul style="list-style-type: none"> - there is no PSU or FOM in the PSU bay, or - a PSU is installed but has a power supply or fan fault, or its temperature has exceeded its recommended threshold, or - an FOM is installed and a fan has failed. <p>Note - No FOM is OK for AT-9924T and AT-9924SP.</p>
DUPLEX	Green	The port is operating at full duplex.
	Orange	The port is operating at half duplex.
	Gray	The port has no link.

Note - Please refer to Uplink Modules for the operations and behavior of the Expansion Modules installed on these devices.

Agent Menu

From the Agent menu, you can view and edit the system information for the switch, or log into the CLI using Telnet.

System Info

Displays basic system information, including system name, location, contact and description.

Firmware Info

Displays a list of software releases installed on the switch.

Power Supply Info

Displays information about the power supply.

File List

Displays a list of the files in the switch's file system.

Config File Name

Displays the file name of the start-up configuration file.

Chassis Temperature and Fan Info

Displays the actual temperature of the switch, the temperature status, and the fan status.

Reset

Reset Cold resets the hardware and executes the default configuration file. Reset Warm performs a warm start of the software modules and executes the default configuration file.

Telnet

Starts a Telnet connection to the switch.

WEB Browser

Opens your web browser and connects to the switch's HTTP server.

Note - The web browser can only contact the device if the device has a valid resource file loaded and set, and the HTTP server and GUI on the device are enabled.

Routing Menu

From the Routing menu, you can view and edit information about the switch's IP routing functions.

ARP Table

Displays the ARP cache on the switch.

Address Table

Displays the list of IP interfaces on the switch.

Route Table

Displays the IP routing table on the switch.

IP Statistics

Displays statistics about IP, such as the number of IP datagrams received.

ICMP Statistics

Displays statistics about ICMP, such as the number of ICMP datagrams received.

Bridge Menu

From the Bridge menu, you can view and edit bridge information such as the forwarding database and the spanning tree status.

Forwarding Database

Standard View

Displays the Forwarding Database table as returned by the device.

Enhanced View

Displays the Forwarding Database table on a per port basis. User can select a port or group of ports to view its corresponding Forwarding Database entries.

Discard/Aging Time Info

Displays information about the number of address entries that were learned but discarded for reasons such as lack of memory or the entry's aging timer.

Spanning Tree Info

Displays spanning tree parameters such as priority and cost.

Statistics

Displays statistics about frames received/transmitted on the switch port.

Port Menu

From the Port menu, you can view and edit MIB information about the port.

Utilization

Displays the port's utilization information.

Interface Info

Displays port statistics such as the number of frames received and transmitted on the port, bytes received and transmitted on the port, and port status.

Error Statistics

Displays error statistics.

Spanning Tree Info

Displays the port's spanning tree parameters.

MAU Info

Displays interface-related MAU information for the port.

MAU Negotiation Info

Displays the MAU's auto-negotiation settings and its status.

Enable

Enables the port.

Disable

Disables the port.

AT-x600 Series

This section describes Device Manager menus and operations specific to the AT-x600 Series Advanced Layer 3 Gigabit Switches.

Topics:

- Main Window
- Agent Menu
- Routing Menu
- Bridge Menu
- Availability Menu
- RMON Menu
- Port Menu
- Stacking Menu

Main Window

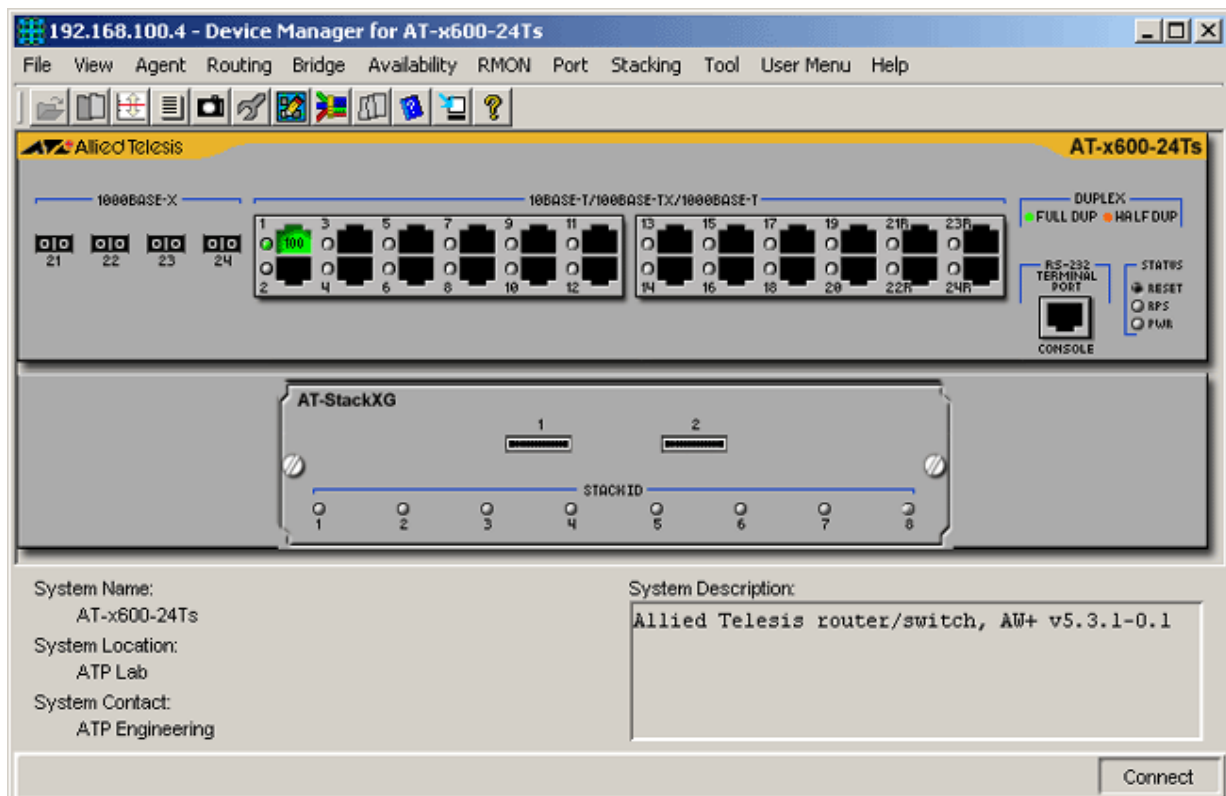

AT-x600-24Ts

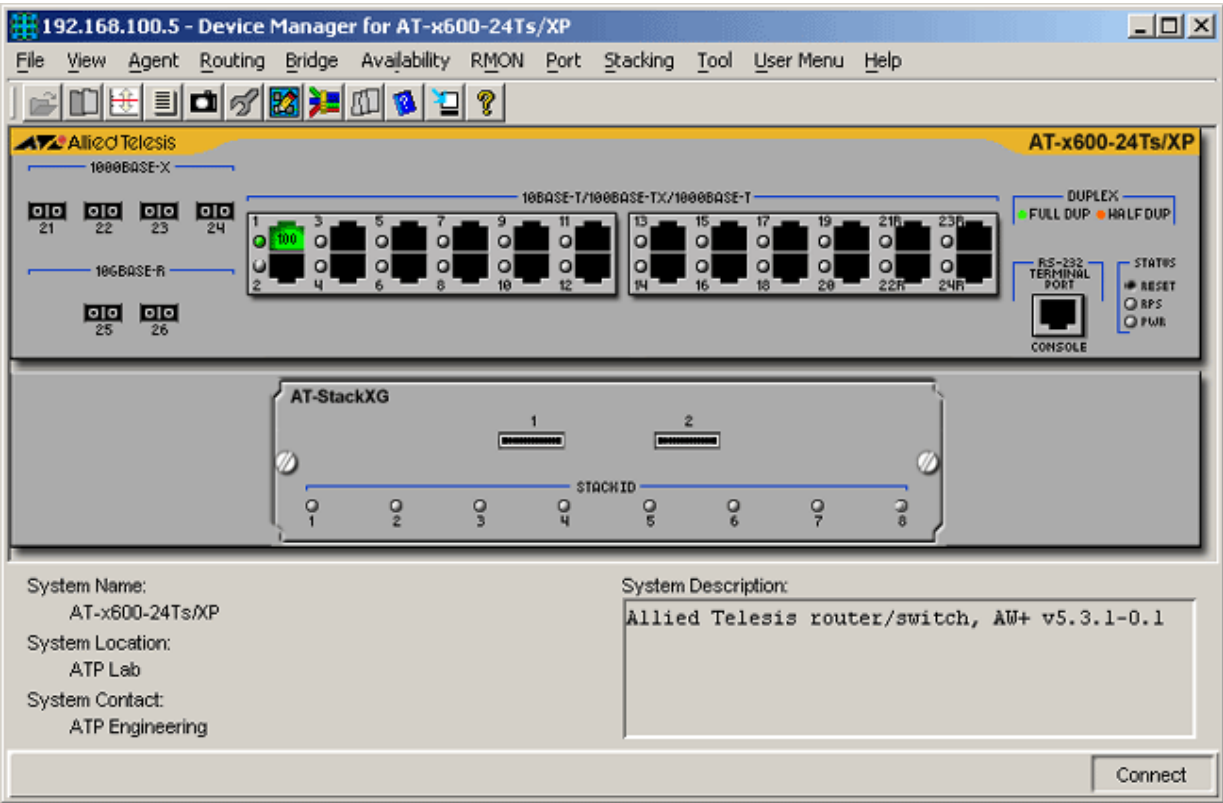

AT-x600-24Ts/XP

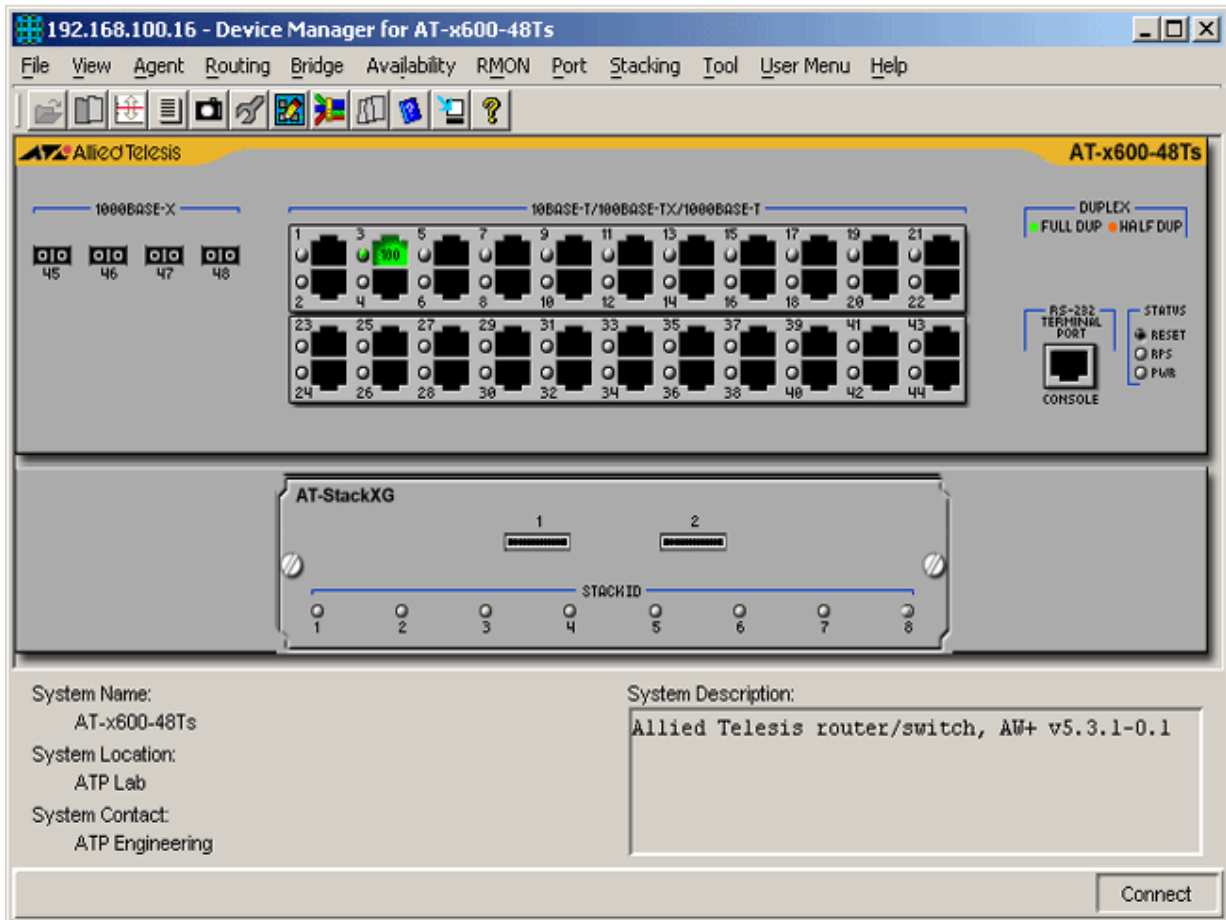

AT-x600-48Ts

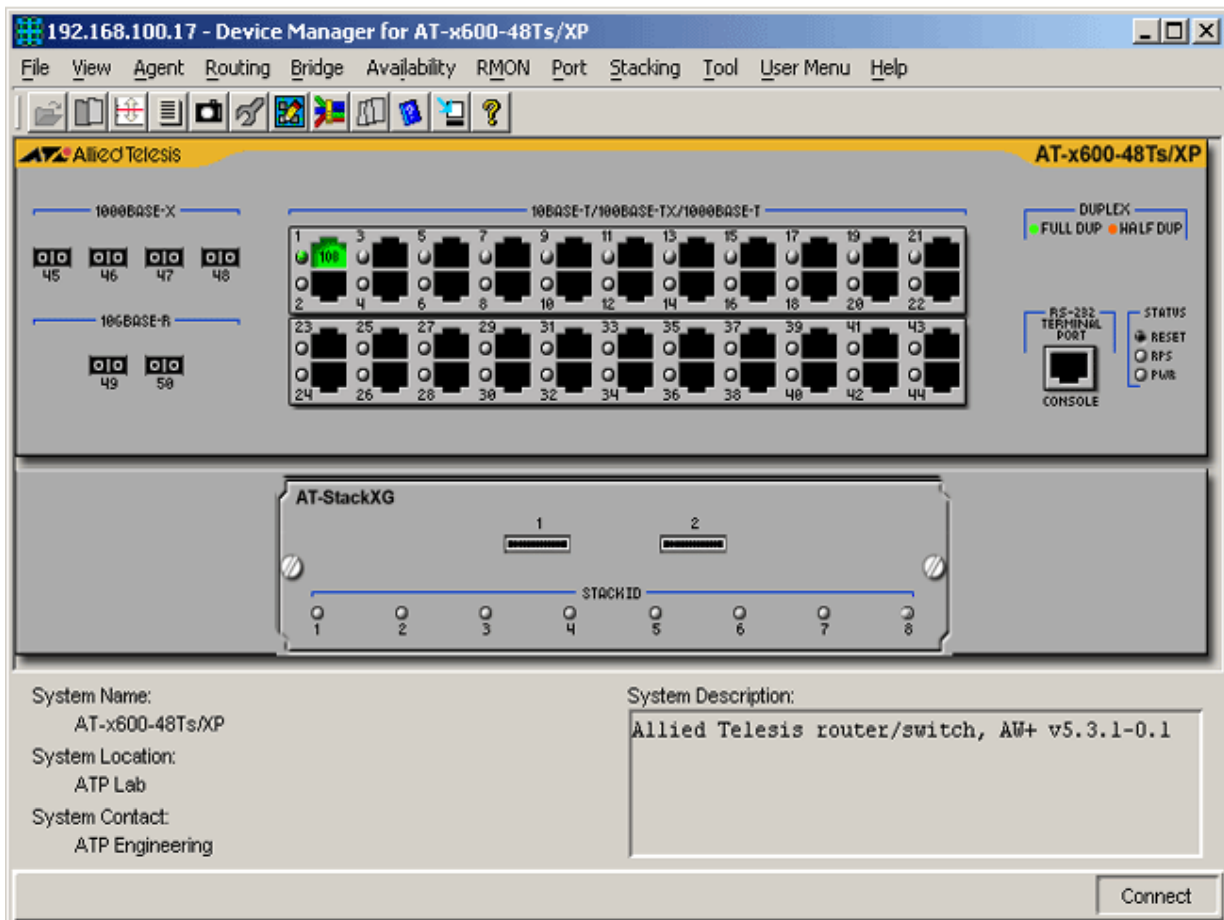

AT-x600-48Ts/XP

Device Manager LEDs for the AT-x600 Series

LED	State	Description
PWR	Green	The Power Supply Unit (PSU) is installed and functioning in the PSU bay.
	Gray	The Power Supply Unit (PSU) is either not installed or not functioning in the PSU bay.
DUPLX	Green	The port is operating at full duplex.
	Orange	The port is operating at half duplex.
RPS	Green	An optional redundant power supply is connected to the switch and is turned on.
	Gray	There is no redundant power supply connected to the switch.
	Orange	An optional redundant power supply is connected to the switch but is turned off.

Device Manager LEDs for the AT-x600 Series		
LED	State	Description
STACK ID	Green	The stacked unit is either the Stacking Master or the Backup Master.
	Gray	The switch is set to standalone mode.
	Orange	The stacked unit is a slave switch.

Note - Please refer to Uplink Modules for the operations and behavior of the Expansion Modules installed on these devices.

Note - The current firmware version does not allow Device Manager to support the PWR and RPS LEDs.

Note - The current firmware version does not allow Device Manager to detect the presence or absence of an SFP module in any of the SFP slots. As a result, the SFP slots on the device image and uplink module image will always show SFP images regardless of whether or not SFP modules are physically present in the slots.

Note - The current firmware version does not allow Device Manager to detect the presence or absence of an XFP module in any of the XFP slots. As a result, the XFP slots on the uplink module image will always show XFP images regardless of whether or not XFP modules are physically present in the slots.

Note - When the Spanning Tree Status parameter is set to 'enabled', the current firmware version continues to return a value of 'forwarding' for the Port State parameter of blocking ports. As a result, blocking ports will remain green and will not turn to yellow.

Note - Status information for combo ports will always be reflected on both the RJ-45 port images and the SFP port images regardless of whether it is the RJ-45 or the SFP ports that are actually in operation.

Note - The current firmware version intermittently fails to reinitialize SNMP agent once the device is restarted. As a result, Device Manager intermittently fails to re-establish connection with the device. To re-establish connection, user will need to re-issue the SNMP commands from the command line interface.

Agent Menu

From the Agent menu, you can view and edit the system information for the switch, or log into the CLI using Telnet.

System Info
Standard

Displays basic system information, including system name, location, contact and description.

Note - Valid MIB Set values for the System Contact and System Location parameters are up to 255 characters. Attempting to enter values greater than the valid range will be accepted but values exceeding 255 characters will be truncated.

Note - Valid MIB Set values for the System Name parameter is up to 255 characters. However, values exceeding 64 characters will be truncated.

Note - The current firmware version allows the System Name parameter to be set to 'NULL'. However, attempting to set this parameter to value 'NULL' will set it to its default value 'awplus'.

Enterprise

CPU Utilization

Displays information about the CPU utilization over different periods of time.

Fan Speeds

Displays information about fans installed in the device that have their fan speeds monitored by environment monitoring hardware.

Voltage Rails

Displays information about voltage rails in the device that are monitored by environment monitoring hardware.

Temperature Sensors

Displays information about the temperature monitored by the temperature sensors in the device.

LED Faults

Displays information about the LEDs on the device.

Contact Details / Memory

Displays Contact Details information and Memory information of the device.

Host Resources

General System Info

Displays general information about the host resources.

Note - Device Manager does not handle objects of type OCTET STRING correctly. As a result, the Time and Date parameter will display a sequence of bytes in hexadecimal format instead of the actual date and time of day.

Note - The Time and Date, Initial Load Device and Initial Load Parameter parameters are implemented as 'read-only'.

Logical Storage Areas

Displays resource information about the storage devices.

Note - The current firmware version returns a "noSuchName" value for the Allocation Failures parameter.

Note - The Storage Size parameter is implemented as 'read-only'.

Devices

Displays resource information about the devices installed in the host.

Note - The current firmware version returns the value 'NULL' for the Device ID parameter.

Processors

Displays basic information about the processor installed in the host.

Note - Device Manager does not handle objects of type OCTET STRING correctly. As a result, the Firmware Product ID parameter will display a sequence of bytes in hexadecimal format instead of the actual integer value.

Running Software

Displays each distinct piece of software that is running or loaded into physical or virtual memory of the device.

Note - The current firmware version returns the value 'NULL' for the Run ID parameter.

Note - The Status parameter is implemented as 'read-only'.

Software Performance

Displays the CPU and Memory Software running performance of the device.

Host Info

Displays the host information of the device.

Hardware Info

Installed Modules Info

Displays information about the expansion modules installed in the device.

Note - The current firmware version does not allow the Board Bay parameter to be configured. Attempting to configure this parameter to any valid value will result in the error "The error occurred with 'Set' operation. Error: gen error".

Firmware Info

Current Firmware

Displays information about the current software version installed in the device.

Note - Configuring the Save Current Software parameter to values greater than its valid range will be accepted but will cause the device to restart intermittently.

Note - The current firmware version allows the Save Current Software parameter to be set to a 'null' value. However, the Save Current Software parameter will always return 'saving (null)' value and will not be configurable unless the switch is restarted.

Note - The SNMP agent may take awhile to respond if the Save Current Software parameter has been set to 'saving'. When this happens, it may take a while for device information to be displayed in Device Manager.

Next Boot Firmware

Displays the version of the firmware that the device is currently set to boot from and its full path.

Backup Firmware

Displays the backup software version and its path in the device.

Software License Info

Base License

Displays information about the installed base software licenses on the device.

Installed Licenses

Displays information about the software licenses installed on the device.

Note - The current firmware version returns inconsistent values for the Index and Stack ID parameters.

Note - Configuring the Row Status parameter to 'destroy' as its value will result to an error message "The error occurred with 'Set' operation. Error: time out occurred". However, the value is still set successfully.

Features Info

Displays information about the feature licenses installed on the device.

Install New License

Allows the user to install a new license on the device.

Note - Configuring the Name and Key parameters to value 'NULL' will cause the device to restart intermittently.

Note - The SNMP agent may take awhile to respond if the Name and Key parameters have been set to value 'NULL'. When this happens, it may take a while for device information to be displayed in Device Manager.

File System

Standard

Displays the standard file system information of the device.

Note - Device Manager does not handle objects of type OCTET STRING correctly. As a result, the Last Full Backup Date and Last Partial Backup Date parameter will display a sequence of bytes in hexadecimal format instead of the actual date and time of day.

Note - The Last Full Backup Date and Last Partial Backup Date parameters are implemented as 'read-only'.

Enterprise

File Options Parameters

Displays information about the file options on the device.

File Information

Displays information about the files saved on the device.

Note - The current firmware version returns a 'noSuchName' value intermittently for the File Information parameter when using SNMPv1.

Note - The current firmware version does not return values for the File Size, File Creation Time and File Attributes parameters intermittently when using an SNMPv3 account.

File Operations

Allows user to perform copy, move and delete file operations on the device.

Note - The current firmware version allows the Copy Begin, Move Begin and Delete Begin parameters to be set to '1' even if the values set in the Source Stack ID and Destination Stack ID parameters are incorrect. However, copy, move or delete operation will not be successful.

SD Card

Displays information about the installed SD cards.

Config File Info

Device Configurations

Current Config

Allows the user to save and set the running configuration of the device to its flash.

Next Boot Config

Displays the full path of the configuration file to use the next time the device is rebooted.

Default Config

Displays the default config file info of the device.

GUI Configurations

Displays the latest GUI applet file residing in the root directory of flash that is applicable to the currently running system software.

CLI Servers

Displays information about CLI Servers.

Users

User Info

Displays the information about the users currently logged in the device.

User Config

Displays the information about the users configured in the local user database of the device.

NTP

Peers

Displays the NTP Peer Information on the device.

Note - The current firmware version does not allow the Row Status parameter to be set to 'active' as its value. Attempting to do so will result in the error message "The error occurred with 'Set' operation. Error: time out occurred".

Note - Valid MIB Set values for the Name Address parameter is from 1 to 256 characters. However, the current firmware version allows the user to enter values greater than the valid range.

Associations

Displays the NTP Association on the device.

NTP Info

Displays the peer index's next available value.

System Log

Log Entries

Displays information of the log entries on the device.

Note - The current firmware version returns a 'noSuchName' value intermittently for the Log Entries parameter when using SNMPv1.

Log Options

Displays the log options on the device.

Trigger

Trigger Info

Displays the trigger configuration information in the device.

Trigger Counters

Displays counters in activation of the triggers in the device.

Remote Ping

Ping Objects

Displays the maximum number of concurrent active ping requests.

Note - The Target Address Type parameter is implemented as 'read-only'.

Ping Control

Defines the Ping Control Table for providing, via SNMP, the capability of performing ping operations at a remote host.

Note - The current firmware version returns a 'noSuchName' value for the Owner Index and Test Name parameters.

Note - Device Manager does not handle MIB table with Read-Create access correctly. Attempting to set any parameters of this table will result in the error "The Error occurred with 'Set' operation.Error:NoSuchname".

Ping Results

Displays the results of the performed ping operations in the Ping Control table.

Note - Device Manager does not handle objects of type OCTET STRING correctly. As a result, the Target IP Address parameter will display a sequence of bytes in hexadecimal format instead of the actual IP address of the remote host.

Note - Device Manager does not handle objects of type OCTET STRING correctly. As a result, the Last Good Probe parameter will display a sequence of bytes in hexadecimal format instead of the actual date and time of day.

Ping Probe History Table

Displays ping probe history in performing ping operations.

Note - The current firmware version returns a 'noSuchName' value for the Ping Probe History Table parameters.

Restart Device

Initiates a restart on the switch.

Telnet

Starts a Telnet connection to the switch.

WEB Browser

Connects to the switch's HTTP server.

Routing Menu

From the Routing menu, you can view and edit information about the switch's IP routing functions.

IP

Address Table

Standard

Displays the list of IP interfaces on the switch.

Note - The Re-assemble Max Size parameter is not applicable to the AT-x600 series and should be ignored.

Additional Info

Displays the information of the IP Address of the device.

Note - Device Manager does not handle objects of type OCTET STRING correctly. As a result, the Address parameter will display a sequence of bytes in hexadecimal format instead of the actual IP address of the device.

Note - The current firmware version does not allow the Port Number and Assignment Type parameters to be configured.

Note - The current firmware version allows the user to enter up to 128 characters for the Label parameter but truncates entered values to 127 characters.

Note - Configuring Prefix Length parameter will result in the error message "The error occurred with 'Set' operation. Error: time out occurred." However, the new value is still set successfully.

Route Number

Displays the IP routing number on the switch.

Route Table

Displays the IP routing table on the switch.

Note - The current firmware version returns the value 'NULL' for the Routing Protocol MIB parameter.

Note - The following parameters are implemented as 'read-only':

- Destination Port Number
- Routing Type
- Routing Protocol MIB

- Next Hop AS Number
- Destination Metric 1
- Destination Metric 2
- Destination Metric 3
- Destination Metric 4
- Destination Metric 5
- Row Status

IP Statistics

Displays statistics about IP, such as the number of IP datagrams received.

Note - Valid MIB Set values for the Default TTL parameter should range from 1-255. However, the current firmware version does not allow this parameter to be set to '1' as its value. Attempting to set this parameter to '1' will result in the error message "The error occurred with 'Set' operation: time out occurred." Connection with the device will be lost and the only way to re-establish connection will be to perform a manual reset.

Note - Setting the Forwarding Status parameter to 'not forwarding' will not return an error message but connection with the device will be lost. The only way to re-establish connection will be to perform a manual reset.

UDP

Listener Info

Displays UDP listener information.

UDP Statistics

Displays UDP statistics.

TCP

Connection Info

Displays TCP connection-specific information.

Note - The Connection Status parameter is implemented as 'read-only'.

TCP Statistics

Displays TCP statistics.

ICMP Statistics

Displays ICMP statistics.

DNS

DNS Server

Displays DNS server information.

Note - The current firmware version does not allow the Status parameter to be set to 'active' as its value. Attempting do so will result in the error message "The error occurred with 'Set' operation. Error: time out occurred".

DNS Client
Displays DNS Client information.

Bridge Menu

From the Bridge menu, you can view and edit bridge information such as the forwarding database and the spanning tree status.

Forwarding Database

Standard View

Displays the Forwarding Database table as returned by the device.

Enhanced View

Displays the Forwarding Database table on a per port basis. User can select a port or group of ports to view its corresponding Forwarding Database entries.

Discard/Aging Time Info

Displays information about the number of address entries that were learned but discarded for reasons such as lack of memory or the entry's aging timer.

Note - Valid MIB Set values for the Aging Time parameter is in the range [10-630] inclusive.

Note - Values entered for the Aging Time parameter must be multiples of 10. Values that are not multiples of 10 will be automatically rounded down to the nearest tens.

Spanning Tree Info

Displays spanning tree parameters such as priority and cost.

Statistics

Displays statistics about frames received/transmitted on the switch port.

Basic Bridge Info

Displays basic bridge information.

Bridge Port Info

Displays bridge port information.

Note - The current firmware version returns the value 'NULL' for the Circuit parameter.

802.1p

Device Capabilities

Displays the device capabilities information.

Traffic Class

Displays the bridge traffic class and received traffic class info.

Note - The Traffic Class Priority parameter is not applicable to the AT-x600 series and should be ignored.

Note - The Received Traffic Class parameter is implemented as 'read-only'.

Availability Menu

From the Availability menu, you can view the EPSR MIB.

EPSR

Displays the EPSR information of the device.

RMON Menu

From the RMON menu, you can view and edit the RMON MIB.

Statistics

Displays traffic statistics in the network segment attached to each port.

History Control Table

Displays the RMON History table.

Note - Device Manager does not handle MIB table with Read-Create access correctly. Attempting to set any parameters of this table will not be successful.

Alarm Table

Displays the RMON Alarm table.

Event Table

Displays the RMON Event table.

Event Log

Displays the RMON Event log.

Port Menu

From the Port menu, you can view and edit MIB information about the port.

Utilization

Displays the port's utilization information.

Interface Info

Standard

Displays high-capacity port statistics including received and transmitted unicast/multicast/broadcast packets on the port, link up/down trap and port speed.

Note - The following parameters are not applicable to the the AT-x600 series and should be ignored:

- Specific Media MIB
- Received Non Unicast Packets
- Transmitted Non Unicast Packets
- Transmitted Buffer Length

Note - Device Manager will not display the correct state of the ports and duplex LEDs if logged-on in SNMPv3 mode using a user account with no read access to the Interface Info parameters.

Additional Info

Displays port statistics such as the number of frames received and transmitted on the port, bytes received and transmitted on the port, and port status.

Note - The current firmware version returns a 'noSuchName' value for the following parameters:

- Received Bytes (HC)
- Received Unicast Packets (HC)
- Received Multicast Packets (HC)
- Received Broadcast Packets (HC)
- Transmitted Bytes (HC)
- Transmitted Unicast Packets (HC)
- Transmitted Multicast Packets (HC)
- Transmitted Broadcast Packets (HC)

Note - The Promiscuous Mode parameter is implemented as 'read-only'.

Note - The Counter Discontinuity Time parameter is not applicable to the AT-x600 series and should be ignored.

Note - Valid MIB Set values for the Port Alias parameter is up to 64 characters. Attempting to enter values greater than the valid range will be accepted but values exceeding 64 characters will be truncated.

Error Statistics

Displays error statistics.

Note - The Ethernet Chipset parameter is not applicable to the AT-x600 series and should be ignored.

Received Address

Displays the address for which the system will accept packets/frames on the particular interface.

Note - The Received Address parameter is not applicable to the AT-x600 series and should be ignored

Note - The Received Address Status and Received Address Type parameters are implemented as 'read-only'.

Spanning Tree Info

Standard

Displays the port's spanning tree parameters.

Note - Valid MIB Set values for the Port Path Cost parameter is in the range [1-65535] inclusive.

Note - The current firmware version does not allow the Port parameter to be configured.

Additional Info

Displays additional information on the port's spanning tree parameters.

Note - The current firmware version does not allow the Protocol Migration parameter to be set to 'true'.

Note - The current firmware version does not allow the Point-to-Point Config parameter to be set to 'auto'.

Note - Valid MIB Set values for the Port Path Cost Config parameter is [1-200000000] inclusive. However, the current firmware version allows the user to set this parameter to '0' as its value and will automatically set the entered value to valid values.

MAC Control Pause

Displays information about the MAC Control Pause function on a single ethernet-like interface.

Note - The current firmware version returns a 'noSuchName' value for the Received Frames (HC) and Transmit Frames (HC) parameters.

Note - The PAUSE Config parameter is implemented as 'read-only'.

MAU Info

Displays interface-related MAU information for the port.

Note - The MAU Status and Default MAU Type parameters are implemented as 'read-only'.

Note - The MAU Type List parameter is not applicable to the AT-x600 series and should be ignored.

Note - The Mau Type List Bits and HC False Carriers parameters are not applicable to the AT-x600 series and should be ignored.

Note - The current firmware version returns the value 'NULL' for the MAU Type and Default MAU Type parameters.

MAU Negotiation Info

Displays the MAU's auto-negotiation settings and its status.

Note - The Administration Status and Restart parameters are implemented as 'read-only'.

Note - The Advertised Negotiation Capability parameter is not applicable to the AT-x600 series and should be ignored.

Note - The Negotiation Capability, Advertised Negotiation Capability and Received Negotiation Capability parameters are not applicable to the AT-x600 series and should be ignored.

Note - The following parameters are not applicable to the AT-x600 series and should be ignored:

- Capability Bits
- Advertised Bits
- Received Bits
- Remote Fault Advertised
- Remote Fault Received

Aggregator Port List

Displays Link Aggregation Control information for every Aggregation Port associated with this device.

Note - The current firmware version returns a 'noSuchName' value for the Partner Administrative System ID and Partner Operational System ID parameters.

Note - The current firmware version does not allow the Actor Administrative Status and Partner Administrative Status parameter to be configured. Attempting to configure this parameter to any valid value will result in the error "The error occurred with 'Set' operation. Error: gen error".

Note - The current firmware version does not allow the following parameters to be set to '0'.

- Partner Administrative System Priority
- Partner Administrative Port
- Partner Administrative Port Priority

Enable

Enables the port.

Disable

Disables the port.

Stacking Menu

From the Stacking menu, you can view and edit the Stacking MIB.

Stack Status

Displays the stack status information of the device.

Stack Info

Displays information about the stacked devices.

AT-x900-12X Series

This section describes Device Manager menus and operations specific to the AT-x900-12X Series Advanced Layer 3 Gigabit Switches.

Topics:

- Main Window
- Agent Menu
- Routing Menu
- Bridge Menu
- Availability Menu
- RMON Menu
- Port Menu
- Stacking Menu

Main Window

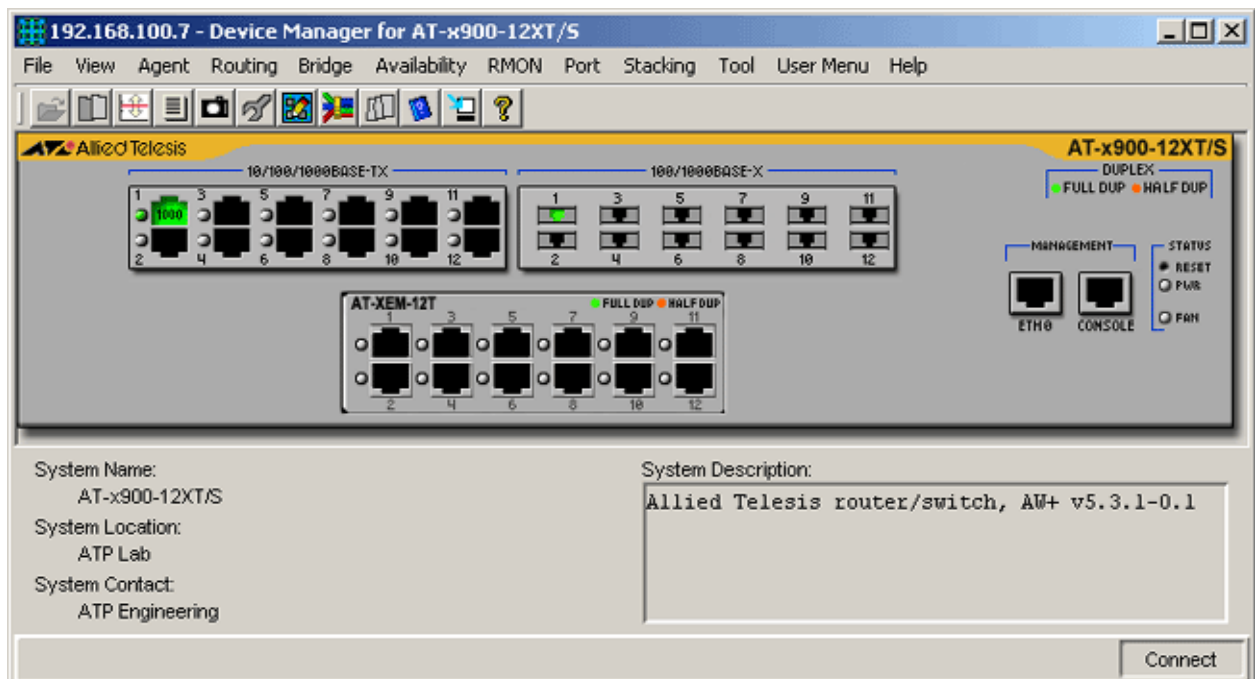

AT-x900-12XT/S

Device Manager LEDs for the AT-x900-12X Series		
LED	State	Description
PWR	Green	The Power Supply Unit (PSU) is installed and functioning in the PSU bay.
FAN	Green	The Fan Module is installed and functioning in the PSU bay.
	Gray	The Fan Module is either not installed or not functioning in the PSU bay.
DUPLEX	Green	The port is operating at full duplex.
	Orange	The port is operating at half duplex.
STACK ID	Green	The stacked unit is either the Stacking Master or the Backup Master.
	Gray	The switch is set to standalone mode.
	Orange	The stacked unit is a slave switch.

Note - Please refer to Uplink Modules for the operations and behavior of the Expansion Modules installed on these devices.

Note - The current firmware version does not allow Device Manager to support the PWR and FAN LEDs.

Note - The current firmware version does not allow Device Manager to detect the presence or absence of an SFP module in any of the SFP slots. As a result, the SFP slots on the device image and uplink module image will always show SFP images regardless of whether or not SFP modules are physically present in the slots.

Note - The current firmware version does not allow Device Manager to detect the presence or absence of an XFP module in any of the XFP slots. As a result, the XFP slots on the uplink module image will always show XFP images regardless of whether or not XFP modules are physically present in the slots.

Note - When the Spanning Tree Status parameter is set to 'enabled', the current firmware version continues to return a value of 'forwarding' for the Port State parameter of blocking ports. As a result, blocking ports will remain green and will not turn to yellow.

Note - Status information for combo ports will always be reflected on both the RJ-45 port images and the SFP port images regardless of whether it is the RJ-45 or the SFP ports that are actually in operation.

Agent Menu

From the Agent menu, you can view and edit the system information for the switch, or log into the CLI using Telnet.

System Info

Standard

Displays basic system information, including system name, location, contact and description.

Note - Valid MIB Set values for the System Contact and System Location parameters are up to 255 characters. Attempting to enter values greater than the valid range will be accepted but values exceeding 255 characters will be truncated.

Note - Valid MIB Set values for the System Name parameter is up to 255 characters. However, values exceeding 64 characters will be truncated.

Note - The current firmware version allows the System Name parameter to be set to 'NULL'. However, attempting to set this parameter to value 'NULL' will set it to its default value 'awplus'.

Enterprise

CPU Utilization

Displays information about the CPU utilization over different periods of time.

Fan Speeds

Displays information about fans installed in the device that have their fan speeds monitored by environment monitoring hardware.

Voltage Rails

Displays information about voltage rails in the device that are monitored by environment monitoring hardware.

Temperature Sensors

Displays information about the temperature monitored by the temperature sensors in the device.

Power Supply Bay Sensors

Displays information about device installed in the Power Supply Bay.

LED Faults

Displays information about the LEDs on the device.

Contact Details / Memory

Displays Contact Details information and Memory information of the device.

Host Resources

General System Info

Displays general information about the host resources.

Note - Device Manager does not handle objects of type OCTET STRING correctly. As a result, the Time and Date parameter will display a sequence of bytes in hexadecimal format instead of the actual date and time of day.

Note - The Time and Date, Initial Load Device and Initial Load Parameter parameters are implemented as 'read-only'.

Logical Storage Areas

Displays resource information about the storage devices.

Note - The current firmware version returns a "noSuchName" value for the Allocation Failures parameter.

Note - The Storage Size parameter is implemented as 'read-only'.

Devices

Displays resource information about the devices installed in the host.

Note - The current firmware version returns the value 'NULL' for the Device ID parameter.

Processors

Displays basic information about the processor installed in the host.

Note - Device Manager does not handle objects of type OCTET STRING correctly. As a result, the Firmware Product ID parameter will display a sequence of bytes in hexadecimal format instead of the actual integer value.

Running Software

Displays each distinct piece of software that is running or loaded into physical or virtual memory of the device.

Note - The current firmware version returns the value 'NULL' for the Run ID parameter.

Note - The Status parameter is implemented as 'read-only'.

Software Performance

Displays the CPU and Memory Software running performance of the device.

Host Info

Displays the host information of the device.

Hardware Info

Total Expansion Modules Installed

Displays the number of expansion modules installed in the device.

Installed Modules Info

Displays information about the expansion modules installed in the device.

Note - The current firmware version does not allow the Board Bay parameter to be configured. Attempting to configure this parameter to any valid value will result in the error "The error occurred with 'Set' operation. Error: gen error".

Firmware Info

Current Firmware

Displays information about the current software version installed in the device.

Note - Configuring the Save Current Software parameter to values greater than its valid range will be accepted but will cause the device to restart intermittently.

Note - The current firmware version allows the Save Current Software parameter to be set to a 'null' value. However, the Save Current Software parameter will always return 'saving (null)' value and will not be configurable unless the switch is restarted.

Note - The SNMP agent may take awhile to respond if the Save Current Software parameter has been set to 'saving'. When this happens, it may take a while for device information to be displayed in Device Manager.

Next Boot Firmware

Displays the version of the firmware that the device is currently set to boot from and its full path.

Backup Firmware

Displays the backup software version and its path in the device.

Software License Info

Base License

Displays information about the installed base software licenses on the device.

Installed Licenses

Displays information about the software licenses installed on the device.

Note - The current firmware version returns inconsistent values for the Index and Stack ID parameters.

Note - Configuring the Row Status parameter to 'destroy' as its value will result to an error message "The error occurred with 'Set' operation. Error: time out occurred". However, the value is still set successfully.

Features Info

Displays information about the feature licenses installed on the device.

Install New License

Allows the user to install a new license on the device.

Note - Configuring the Name and Key parameters to value 'NULL' will cause the device to restart intermittently.

Note - The SNMP agent may take awhile to respond if the Name and Key parameters have been set to value 'NULL'. When this happens, it may take a while for device information to be displayed in Device Manager.

File System

Standard

Displays the standard file system information of the device.

Note - Device Manager does not handle objects of type OCTET STRING correctly. As a result, the Last Full Backup Date and Last Partial Backup Date parameter will display a sequence of bytes in hexadecimal format instead of the actual date and time of day.

Note - The Last Full Backup Date and Last Partial Backup Date parameters are implemented as 'read-only'.

Enterprise

File Options Parameters

Displays information about the file options on the device.

File Information

Displays information about the files saved on the device.

Note - The current firmware version returns a 'noSuchName' value intermittently for the File Information parameter when using SNMPv1.

Note - The current firmware version does not return values for the File Size, File Creation Time and File Attributes parameters intermittently when using an SNMPv3 account.

File Operations

Allows user to perform copy, move and delete file operations on the device.

Note - The current firmware version allows the Copy Begin, Move Begin and Delete Begin parameters to be set to '1' even if the values set in the Source Stack ID and Destination Stack ID parameters are incorrect. However, copy, move or delete operation will not be successful.

SD Card

Displays information about the installed SD cards.

Config File Info

Device Configurations

Current Config

Allows the user to save and set the running configuration of the device to its flash.

Next Boot Config

Displays the full path of the configuration file to use the next time the device is rebooted.

Default Config

Displays the default config file info of the device.

GUI Configurations

Displays the latest GUI applet file residing in the root directory of flash that is applicable to the currently running system software.

CLI Servers

Displays information about CLI Servers.

Users

User Info

Displays the information about the users currently logged in the device.

User Config

Displays the information about the users configured in the local user database of the device.

NTP

Peers

Displays the NTP Peer Information on the device.

Note - The current firmware version does not allow the Row Status parameter to be set to 'active' as its value. Attempting to do so will result in the error message "The error occurred with 'Set' operation. Error: time out occurred".

Note - Valid MIB Set values for the Name Address parameter is from 1 to 256 characters. However, the current firmware version allows the user to enter values greater than the valid range.

Associations

Displays the NTP Association on the device.

NTP Info

Displays the peer index's next available value.

System Log

Log Entries

Displays information of the log entries on the device.

Note - The current firmware version returns a 'noSuchName' value intermittently for the Log Entries parameter when using SNMPv1.

Log Options

Displays the log options on the device.

Trigger

Trigger Info

Displays the trigger configuration information in the device.

Trigger Counters

Displays counters in activation of the triggers in the device.

Remote Ping

Ping Objects

Displays the maximum number of concurrent active ping requests.

Note - The Target Address Type parameter is implemented as 'read-only'.

Ping Control

Defines the Ping Control Table for providing, via SNMP, the capability of performing ping operations at a remote host.

Note - The current firmware version returns a 'noSuchName' value for the Owner Index and Test Name parameters.

Note - Device Manager does not handle MIB table with Read-Create access correctly. Attempting to set any parameters of this table will result in the error "The Error occurred with 'Set' operation.Error:NoSuchname".

Ping Results

Displays the results of the performed ping operations in the Ping Control table.

Note - Device Manager does not handle objects of type OCTET STRING correctly. As a result, the Target IP Address parameter will display a sequence of bytes in hexadecimal format instead of the actual IP address of the remote host.

Note - Device Manager does not handle objects of type OCTET STRING correctly. As a result, the Last Good Probe parameter will display a sequence of bytes in hexadecimal format instead of the actual date and time of day.

Ping Probe History Table

Displays ping probe history in performing ping operations.

Note - The current firmware version returns a 'noSuchName' value for the Ping Probe History Table parameters.

Restart Device

Initiates a restart on the switch.

Note - For devices that is set to standalone mode, while the Reset operation is in progress, error "The error with 'Set' operation. Error: time out occurred." will be displayed and should be ignored.

Telnet

Starts a Telnet connection to the switch.

WEB Browser

Connects to the switch's HTTP server.

Routing Menu

From the Routing menu, you can view and edit information about the switch's IP routing functions.

IP

Address Table

Standard

Displays the list of IP interfaces on the switch.

Note - The Re-assemble Max Size parameter is not applicable to the AT-x900-12X series and should be ignored.

Additional Info

Displays the information of the IP Address of the device.

Note - Device Manager does not handle objects of type OCTET STRING correctly. As a result, the Address parameter will display a sequence of bytes in hexadecimal format instead of the actual IP address of the device.

Note - The current firmware version does not allow the Port Number and Assignment Type parameters to be configured.

Note - The current firmware version allows the user to enter up to 128 characters for the Label parameter but truncates entered values to 127 characters.

Note - Configuring Prefix Length parameter will result in the error message "The error occurred with 'Set' operation. Error: time out occurred." However, the new value is still set successfully.

Route Number

Displays the IP routing number on the switch.

Route Table

Displays the IP routing table on the switch.

Note - The current firmware version returns the value 'NULL' for the Routing Protocol MIB parameter.

Note - The following parameters are implemented as 'read-only':

- Destination Port Number
- Routing Type
- Routing Protocol MIB
- Next Hop AS Number
- Destination Metric 1
- Destination Metric 2
- Destination Metric 3
- Destination Metric 4
- Destination Metric 5
- Row Status

IP Statistics

Displays statistics about IP, such as the number of IP datagrams received.

Note - Valid MIB Set values for the Default TTL parameter should range from 1-255. However, the current firmware version does not allow this parameter to be set to '1' as its value. Attempting to set this parameter to '1' will result in the error message "The error occurred with 'Set' operation: time out occurred." Connection with the device will be lost and the only way to re-establish connection will be to perform a manual reset.

UDP

Listener Info

Displays UDP listener information.

UDP Statistics

Displays UDP statistics.

TCP

Connection Info

Displays TCP connection-specific information.

Note - The Connection Status parameter is implemented as 'read-only'.

TCP Statistics

Displays TCP statistics.

ICMP Statistics

Displays ICMP statistics.

DNS

DNS Server

Displays DNS server information.

Note - The current firmware version does not allow the Status parameter to be set to 'active' as its value. Attempting do so will result in the error message "The error occurred with 'Set' operation. Error: time out occurred".

DNS Client

Displays DNS Client information.

Bridge Menu

From the Bridge menu, you can view and edit bridge information such as the forwarding database and the spanning tree status.

Forwarding Database

Standard View

Displays the Forwarding Database table as returned by the device.

Note - The current firmware version returns the value "00 00 CD 00 00 00" for the Management MAC Address parameter of base port 11.

Enhanced View

Displays the Forwarding Database table on a per port basis. User can select a port or group of ports to view its corresponding Forwarding Database entries.

Discard/Aging Time Info

Displays information about the number of address entries that were learned but discarded for reasons such as lack of memory or the entry's aging timer.

Note - Valid MIB Set values for the Aging Time parameter is in the range [10-630] inclusive.

Note - Values entered for the Aging Time parameter must be multiples of 10. Values that are not multiples of 10 will be automatically rounded down to the nearest tens.

Spanning Tree Info

Displays spanning tree parameters such as priority and cost.

Statistics

Displays statistics about frames received/transmitted on the switch port.

Basic Bridge Info

Displays basic bridge information.

Bridge Port Info

Displays bridge port information.

Note - The current firmware version returns the value 'NULL' for the Circuit parameter.

802.1p

Device Capabilities

Displays the device capabilities information.

Traffic Class

Displays the bridge traffic class and received traffic class info.

Note - The Traffic Class Priority parameter is not applicable to the AT-x900-12X series and should be ignored.

Note - The Received Traffic Class parameter is implemented as 'read-only'.

Availability Menu

From the Availability menu, you can view the EPSR MIB.

EPSR

Displays the EPSR information of the device.

RMON Menu

From the RMON menu, you can view and edit the RMON MIB.

Statistics

Displays traffic statistics in the network segment attached to each port.

History Control Table

Displays the RMON History table.

Note - Device Manager does not handle MIB table with Read-Create access correctly. Attempting to set any parameters of this table will not be successful.

Alarm Table

Displays the RMON Alarm table.

Event Table

Displays the RMON Event table.

Event Log

Displays the RMON Event log.

Port Menu

From the Port menu, you can view and edit MIB information about the port.

Utilization

Displays the port's utilization information.

Interface Info

Standard

Displays high-capacity port statistics including received and transmitted unicast/multicast/broadcast packets on the port, link up/down trap and port speed.

Note - The following parameters are not applicable to the AT-x900-12X series and should be ignored:

- Specific Media MIB
- Received Non Unicast Packets
- Transmitted Non Unicast Packets
- Transmitted Buffer Length

Note - Device Manager will not display the correct state of the ports and duplex LEDs if logged-on in SNMPv3 mode using a user account with no read access to the Interface Info parameters.

Additional Info

Displays port statistics such as the number of frames received and transmitted on the port, bytes received and transmitted on the port, and port status.

Note - The current firmware version returns a 'noSuchName' value for the following parameters:

- Received Bytes (HC)
- Received Unicast Packets (HC)
- Received Multicast Packets (HC)
- Received Broadcast Packets (HC)
- Transmitted Bytes (HC)
- Transmitted Unicast Packets (HC)
- Transmitted Multicast Packets (HC)
- Transmitted Broadcast Packets (HC)

Note - The Promiscuous Mode parameter is implemented as 'read-only'.

Note - The Counter Discontinuity Time parameter is not applicable to the AT-x900-12X series and should be ignored.

Note - Valid MIB Set values for the Port Alias parameter is up to 64 characters. Attempting to enter values greater than the valid range will be accepted but values exceeding 64 characters will be truncated.

Error Statistics

Displays error statistics.

Note - The Ethernet Chipset parameter is not applicable to the AT-x900-12X series and should be ignored.

Received Address

Displays the address for which the system will accept packets/frames on the particular interface.

Note - The Received Address parameter is not applicable to the AT-x900-12X series and should be ignored

Note - The Received Address Status and Received Address Type parameters are implemented as 'read-only'.

Spanning Tree Info

Standard

Displays the port's spanning tree parameters.

Note - Valid MIB Set values for the Port Path Cost parameter is in the range [1-65535] inclusive.

Note - The current firmware version does not allow the Port parameter to be configured.

Additional Info

Displays additional information on the port's spanning tree parameters.

Note - The current firmware version does not allow the Protocol Migration parameter to be set to 'true'.

Note - The current firmware version does not allow the Point-to-Point Config parameter to be set to 'auto'.

Note - Valid MIB Set values for the Port Path Cost Config parameter is [1-200000000] inclusive. However, the current firmware version allows the user to set this parameter to '0' as its value and will automatically set the entered value to valid values.

MAC Control Pause

Displays information about the MAC Control Pause function on a single ethernet-like interface.

Note - The current firmware version returns a 'noSuchName' value for the Received Frames (HC) and Transmit Frames (HC) parameters.

Note - The PAUSE Config parameter is implemented as 'read-only'.

MAU Info

Displays interface-related MAU information for the port.

Note - The MAU Status and Default MAU Type parameters are implemented as 'read-only'.

Note - The MAU Type List parameter is not applicable to the AT-x900-12X series and should be ignored.

Note - The Mau Type List Bits and HC False Carriers parameters are not applicable to the AT-x900-12X series and should be ignored.

Note - The current firmware version returns the value 'NULL' for the MAU Type and Default MAU Type parameters.

MAU Negotiation Info

Displays the MAU's auto-negotiation settings and its status.

Note - The Administration Status and Restart parameters are implemented as 'read-only'.

Note - The Advertised Negotiation Capability parameter is not applicable to the AT-x900-12X series and should be ignored.

Note - The Negotiation Capability, Advertised Negotiation Capability and Received Negotiation Capability parameters are not applicable to the AT-x900-12X series and should be ignored.

Note - The following parameters are not applicable to the AT-x900-12X series and should be ignored:

- Capability Bits
- Advertised Bits
- Received Bits
- Remote Fault Advertised
- Remote Fault Received

Aggregator Port List

Displays Link Aggregation Control information for every Aggregation Port associated with this device.

Note - The current firmware version returns a 'noSuchName' value for the Partner Administrative System ID and Partner Operational System ID parameters.

Note - The current firmware version does not allow the Actor Administrative Status and Partner Administrative Status parameter to be configured. Attempting to configure this parameter to any valid value will result in the error "The error occurred with 'Set' operation. Error: gen error".

Note - The current firmware version does not allow the following parameters to be set to '0'.

- Partner Administrative System Priority
- Partner Administrative Port
- Partner Administrative Port Priority

Enable

Enables the port.

Disable

Disables the port.

Stacking Menu

From the Stacking menu, you can view and edit the Stacking MIB.

Stack Status

Displays the stack status information of the device.

Stack Info

Displays information about the stacked devices.

AT-x900-24X Series (AlliedWare)

This section describes Device Manager menus and operations specific to the AT-x900-24X Series Advanced Layer 3 Gigabit Switches.

Topics:

- Main Window
- Agent Menu
- Routing Menu
- Bridge Menu
- LLDP Menu
- Security Menu
- RMON Menu
- Port Menu

Main Window

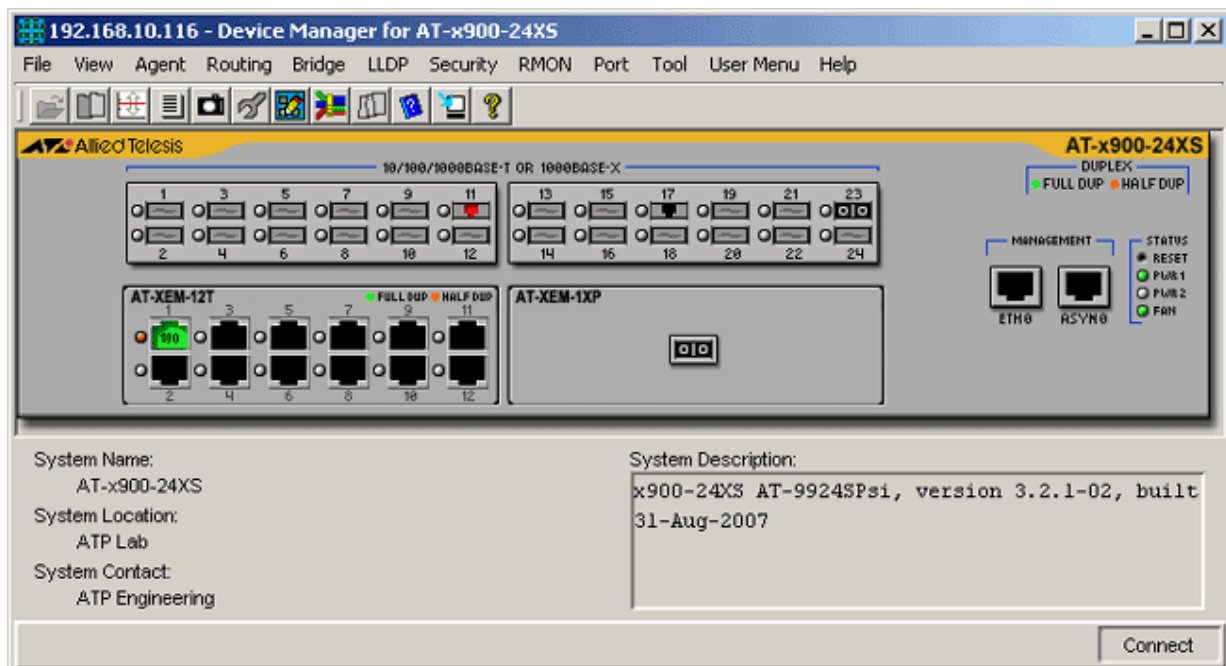

AT-x900-24XS

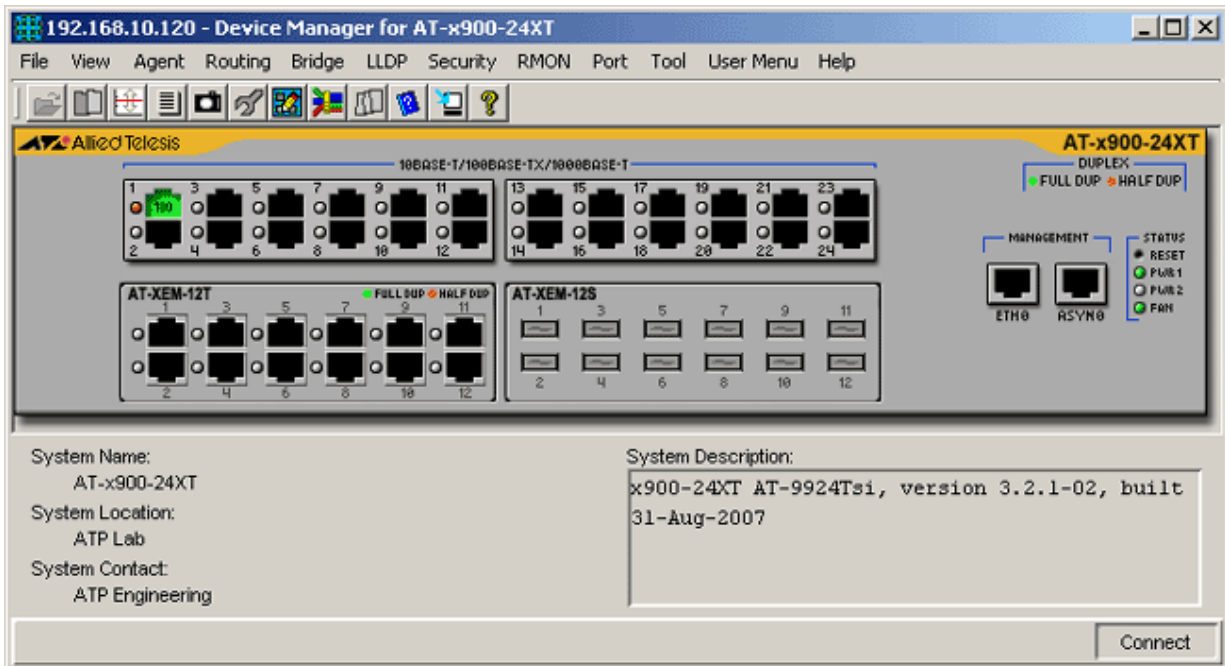

AT-x900-24XT

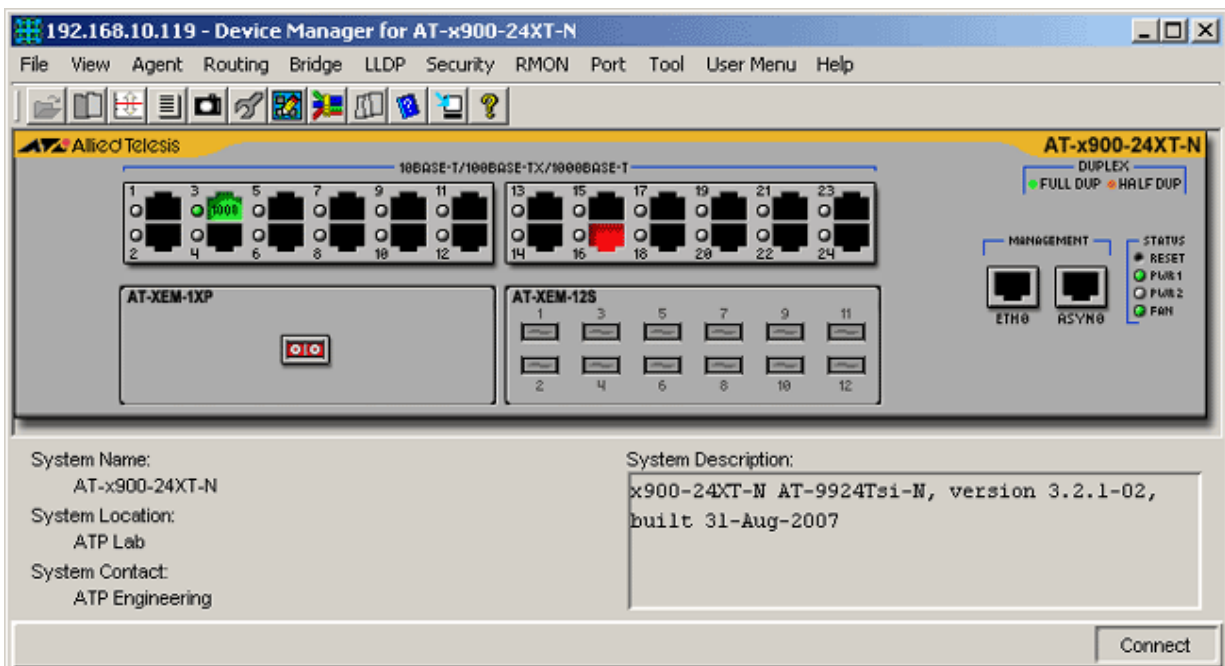

AT-x900-24XT-N

Device Manager LEDs for the AT-x900-24X Series

LED	State	Description
PWR 1 and PWR 2	Green	There is a power supply unit (PSU) in the PSU bay.
	Gray	There is no power supply unit (PSU) in the PSU bay.
FAN	Green	There is a functioning Fan Only Module (FOM) in the PSU bay.

Device Manager LEDs for the AT-x900-24X Series		
LED	State	Description
	Gray	There is no functioning Fan Only Module (FOM) in the PSU bay.
DUPLEX	Green	The port is operating at full duplex.
	Orange	The port is operating at half duplex.

Note - Please refer to Uplink Modules for the operations and behavior of the Expansion Modules installed on these devices.

Note - The PWR LEDs do not reflect the operating state of the power supplies installed. The PWR LEDs simply indicate the presence or absence of power supplies in the rear of the chassis.

Note - The FAN LED does not reflect the operating state of the FAN module installed. The FAN LED simply indicates the presence or absence of a FAN module in the rear of the chassis.

Note - If only one expansion module is installed and it is installed on the right bay of the device, the expansion module image will appear on the left bay of the device image.

Agent Menu

From the Agent menu, you can view and edit the system information for the switch, or log into the CLI using Telnet.

System Info

Standard

Displays basic system information, including system name, location, contact and description.

Enterprise

CPU Utilization

Displays information about the CPU utilization over different periods of time.

Fan Speeds

Displays information about fans installed in the device that have their fan speeds monitored by environment monitoring hardware.

Voltage Rails

Displays information about voltage rails in the device that are monitored by environment monitoring hardware.

Temperature Sensors

Displays information about the temperature monitored by the temperature sensors in the device.

Power Supply Bays

Displays information about the Power Supply Bays in the system and info on any devices that are present.

Power Supply Sensors

Displays information about device installed in the Power Supply Bay.

Host Resources

General System Info

Displays general information about the host resources.

Note - Device Manager does not handle objects of type OCTET STRING correctly. As a result, the Time and Date parameter will display a sequence of bytes in hexadecimal format instead of the actual date and time of day.

Note - The Time and Date and Initial Load Parameter parameters are implemented as 'read-only'.

Logical Storage Areas

Displays resource information about the storage devices.

Note - The Storage Size parameter is implemented as 'read-only'.

Devices

Displays resource information about the devices installed in the host.

Note - The current firmware version returns an incorrect value for the Device ID parameter.

Processors

Displays basic information about the processor installed in the host.

Note - The current firmware version returns the value 'NULL' for the Firmware Product ID parameter.

Host Info

Displays the host information of the device.

Hardware Info

Total Boards

Displays the number of boards that are currently installed.

Board Info

Displays basic information on the boards that are currently installed.

Note - The current firmware version returns the value "boards(272)" for the Board ID parameter of the AT-x900-24XS.

Slot Info

Displays information on the Power Supply Bay slots.

Physical Interfaces

Displays information about the interfaces found in the device.

Firmware Info

Install Configurations

Displays information about the Software release currently loaded in the device.

Note - The current firmware version returns a 'noSuchName' value for the Release File Exists? and Patch File Exists? parameters.

Configuration File

Displays the Configuration file name.

Note - The current firmware version accepts inputs from 4 to 38 characters for the Startup Config and Save Running Config parameters.

Release Licenses

Displays a list of software releases installed on the switch.

Note - The current firmware version does not allow any of the parameters under this table to be configured.

File System

Total Files

Displays the total number of files stored in the device.

File List

Displays a list of the files in the switch's file system.

Note - The current firmware version does not allow the File Status parameter to be configured.

Loader

Load Status

Displays the status of the device loader.

Note - The current firmware version does not allow the Load Status parameter to be set to 'actionupload'.

Load Parameters

Displays information about the files to be loaded.

DHCP Ranges

Displays information about the DHCP module.

Ping Polling

Ping Status

Displays the status of the Ping polling.

Note - Since the Address parameter cannot be configured, the Ping Status parameter cannot also be configured.

Ping Parameters

Displays basic information of the Ping module.

Note - The current firmware version accepts values in the range [1-4294967595] inclusive for the Number of Packets and Time Interval parameters.

Note - Valid MIB Set values for the Timeout parameter should range from 1 to 65535. However, the current firmware version allows the user to enter values in the range [-65535 to -1, 1 to 65535] inclusive. Attempting to enter values greater than 65535 will cause the new value to be converted to its equivalent wrap-around value; i.e., 65536 will become 0, 65537 will become 1, and so on.

Note - Valid MIB Set values for the Number of Packets parameter are in the range [1-4294967295] inclusive. However, attempting to enter values greater than 2147483647 will cause the new value to be converted to its equivalent wrap-around value; i.e., 2147483648 will become -2147483648, 2147483649 will become -2147483647, and so on.

Note - Device Manager does not handle objects of type OCTET STRING correctly. As a result, the Address parameter will not be configurable and will display a sequence of bytes in hexadecimal format instead of the actual destination of ping packets.

Ping Statistics

Displays statistics of the Ping polling.

Reset Cold

Initiates a cold restart on the switch.

Reset Warm

Initiates a warm restart on the switch.

Reset Info

Displays information about the restart.

Telnet

Starts a Telnet connection to the switch.

WEB Browser

Opens your web browser and connects to the switch's HTTP server.

Note - The web browser can only contact the device if the device has a valid resource file loaded and set, and the HTTP server and GUI on the device are enabled.

Routing Menu

From the Routing menu, you can view and edit information about the switch's IP routing functions.

IP

ARP Table

Displays the ARP cache on the switch.

Note - The Physical Address and Mapping Type parameters are implemented as 'read-only'.

Address Table

Displays the list of IP interfaces on the switch.

Route Number

Displays the IP routing number on the switch.

Route Table

Displays the IP routing table on the switch.

Note - The current firmware version returns the value 'NULL' for the Routing Protocol MIB parameter.

Note - The following parameters are implemented as 'read-only':

- Destination Port Number
- Routing Type
- Next Hop AS Number
- Destination Metric 1
- Destination Metric 2
- Destination Metric 3
- Destination Metric 4
- Destination Metric 5
- Row Status

IP Statistics

Displays statistics about IP, such as the number of IP datagrams received.

UDP

Listener Info

Displays UDP listener information.

UDP Statistics
Displays UDP statistics.

TCP

Connection Info
Displays TCP connection-specific information.

Note - The Connection Status parameter is implemented as 'read-only'.

TCP Statistics
Displays TCP statistics.

ICMP Statistics

Displays ICMP statistics.

BGP

General Info
Displays information about the BGP module.

Peer Info
Displays BGP Peer information.

Note - Only the Administration Status parameter can be configured.

Path Attributes
Displays the BGP path attributes.

Bridge Menu

From the Bridge menu, you can view and edit bridge information such as the forwarding database and the spanning tree status.

Forwarding Database

Standard View

Displays the Forwarding Database table as returned by the device.

Enhanced View

Displays the Forwarding Database table on a per port basis. User can select a port or group of ports to view its corresponding Forwarding Database entries.

Discard/Aging Time Info

Displays information about the number of address entries that were learned but discarded for reasons such as lack of memory or the entry's aging timer.

Spanning Tree Info

Displays spanning tree parameters such as priority and cost.

Statistics

Displays statistics about frames received/transmitted on the switch port.

Basic Bridge Info

Displays basic bridge information.

Bridge Port Info

Displays bridge port information.

Note - The current firmware version returns the value 'NULL' for the Circuit parameter.

LLDP Menu

From the LLDP menu, you can view and edit LLDP information such as the LLDP Port Configuration and Local System Data.

LLDP Configuration

General Config

Displays basic LLDP configuration.

Port Config

Displays LLDP configuration for each port.

Note - The current firmware version returns a 'noSuchName' value for the Port Number parameter.

Note - Device Manager does not handle objects of type BITS correctly. As a result, the TLVs Tx Enable parameter will not be configurable and will display an 8-bit binary string instead of the actual TLV types allowed. However, the TLV types allowed can still be determined by looking at the bits that are on from left to right:

- Bit 0 - Port Description
- Bit 1 - System Name
- Bit 2 - System Description
- Bit 3 - System Capabilities

LLDP Statistics

Remote Tables

Displays statistics for the LLDP remote tables.

Port Tx

Displays statistics for LLDP frames transmitted.

Note - The current firmware version returns a 'noSuchName' value for the Port Number parameter.

Port Rx

Displays statistics for received LLDP frames.

Note - The current firmware version returns a 'noSuchName' value for the Port Number parameter.

Local System Data

General Info

Displays information about the local LLDP system.

Port Info

Displays information on the LLDP of local ports.

Note - The current firmware version returns a 'noSuchName' value for the Port Number parameter.

Management Addresses

Displays management addresses of the local LLDP system.

Note - The current firmware version returns the value 'NULL' for the OID parameter.

Security Menu

From the Security menu, you can view and edit port access entity information such as the PAE port information and the Supplicant PAE information.

Port-based Authentication

Authentication Status

Displays the status of the port-based authentication.

PAE Port Info

Standard

Displays standard PAE port information.

Note - The current firmware version returns a 'noSuchName' value for the Port Number parameter.

Note - Device Manager does not handle objects of type BITS correctly. As a result, the Capabilities parameter will display an 8-bit binary string instead of the actual PAE functionality supported. However, the PAE functionality supported can still be determined by looking at the bits that are on from right to left:

- Bit 0 - Authenticator
- Bit 1 - Supplicant

Enterprise

Displays enterprise PAE port information.

Authenticator PAE Info

Standard

Displays standard authenticator PAE information.

Note - The current firmware version returns a 'noSuchName' value for the Port Number parameter.

Note - The Administrative Controlled Directions and Key Transmission Status parameters are implemented as 'read-only'.

Enterprise

Displays enterprise authenticator PAE information.

Authenticator PAE Statistics

Standard

Displays standard statistics for the PAE Authenticator.

Note - The current firmware version returns a 'noSuchName' value for the Port Number parameter.

Enterprise

Displays enterprise statistics for the PAE Authenticator.

Supplicant PAE Info

Displays supplicant PAE information.

Note - The current firmware version returns a 'noSuchName' value for the Port Number parameter.

Supplicant PAE Statistics

Displays the statistics for the PAE supplicant.

Note - The current firmware version returns a 'noSuchName' value for the Port Number parameter.

MAC-based Authentication

PAE Port Info

Displays PAE port information.

Note - The Initialize parameter is implemented as 'read-only'.

Authenticator PAE Info

Displays authenticator PAE information.

RMON Menu

From the RMON menu you can view and edit the RMON MIB.

Statistics

Displays traffic statistics in the network segment attached to each port.

History Control Table

Displays the RMON History table.

Alarm Table

Displays the RMON Alarm table.

Event Table

Displays the RMON Event table.

Event Log

Displays the RMON Event log.

Port Menu

From the Port menu, you can view and edit MIB information about the port.

Utilization

Displays the port's utilization information.

Interface Info

Displays port statistics such as the number of frames received and transmitted on the port, bytes received and transmitted on the port, and port status. This table also displays high-capacity port statistics including received and transmitted unicast/multicast/broadcast packets on the port, link up/down trap and port speed.

Note - The current firmware version returns a 'noSuchName' value for the Port Alias and Counter Discontinuity Time parameters.

Note - Valid MIB Set values for the Administration Status parameter are 'up' and 'down' only.

Note - The Promiscuous Mode parameter is implemented as 'read-only'.

Detail Info

Duplex Mode

Displays the duplex mode of the ports.

Note - Port numbering will vary depending on the number of expansion modules installed and the bay in which they are installed.

Left Bay	Right Bay	Numbering
None	None	1 to 25 (Port 25 is invalid and should be ignored.)
None	AT-XEM-IXP	1 to 26 (Port 25 will not show any valid data. Port 26 is invalid and should be ignored.)
None	AT-XEM-I2S AT-XEM-I2T	1 to 37 (Ports 25 to 36 are invalid and should be ignored. Port 37 will show data for port 1 of the module on the right bay.)
AT-XEM-IXP	None	1 to 26 (Port 25 will show data for the port on the left bay. Port 26 is invalid and should be ignored.)
AT-XEM-I2S AT-XEM-I2T	None	1 to 37 (Ports 25 to 36 will show data for ports on the left bay. Port 37 is invalid and should be ignored.)
AT-XEM-IXP	AT-XEM-IXP	1 to 27 (Port 25 will show data for the port on the left bay. Port 26 will not show any valid data. Port 27 is invalid and should be ignored.)
AT-XEM-IXP	AT-XEM-I2S AT-XEM-I2T	1 to 38 (Port 25 will show data for the port on the left bay. Ports 26 to 36 will not show any valid data. Ports 37 and 38 will show data for ports 1 and 2 of the module on the right bay.)
AT-XEM-I2S AT-XEM-I2T	AT-XEM-IXP	1 to 38 (Ports 25 to 36 will show data for ports on the left bay. Port 37 will show data for the port on the right bay. Port 38 is invalid and should be ignored.)
AT-XEM-I2S AT-XEM-I2T	AT-XEM-I2S AT-XEM-I2T	1 to 49 (Ports 25 to 36 will show data for ports on the left bay. Ports 37 to 48 will show data for ports on the right bay. Port 49 is invalid and should be ignored.)

Bandwidth Limits

Displays bandwidth limits of the switch ports.

Note - The current firmware version does not allow the Ingress Limit parameter to be configured.

Error Statistics

Displays error statistics.

Note - The following parameters are not applicable to the AT-x900-24X series and should be ignored:

- Ethernet Chip Set
- Symbol Errors
- Duplex Status
- Rate Control Ability
- Rate Control Status

Spanning Tree Info

Displays the port's spanning tree parameters.

Note - The Path Cost Contribution parameter is not applicable to the AT-x900-24X series and should be ignored.

Note - Valid MIB Set values for the Port Path Cost parameter is in the range [1-65535] inclusive.

MAU Info

Displays interface-related MAU information for the port.

Note - The MAU Type List Bits and HC False Carriers parameters are not applicable to the AT-x900-24X series and should be ignored.

Note - The MAU Status and Default MAU Type parameters are implemented as 'read-only'.

MAU Negotiation Info

Displays the MAU's auto-negotiation settings and its status.

Note - The following parameters are not applicable to the AT-x900-24X series and should be ignored:

- Capability Bits
- Advertised Bits
- Received Bits
- Remote Fault Advertised
- Remote Fault Received

Note - The Administration Status, Advertised Negotiation Capability and Restart parameters are implemented as 'read-only'.

Port Trunking

Aggregator Port L1st

Displays Link Aggregation Control information for every Aggregation Port associated with this device.

Note - Valid MIB Set values for the Actor System Priority and Actor Port Priority parameters are in the range [0..65535] inclusive.

Note - The following parameters are implemented as 'read-only':

- Actor Operational Key
- Partner Administrative System Priority
- Partner Administrative System ID
- Partner Administrative Key
- Partner Administrative Port
- Partner Administrative Port Priority
- Actor Administrative Status
- Partner Administrative Status

LACP Statistics

Displays Link Aggregation information for every port that is associated with this device.

LACP Debug

Displays Link Aggregation debug information for every port that is associated with this device.

Enable

Enables the port.

Disable

Disables the port.

AT-x900-24X Series (AlliedWare)

AT-x900-24X Series (AlliedWare Plus)

This section describes Device Manager menus and operations specific to the AT-x900-24X Series Advanced Layer 3 Gigabit Switches.

Topics:

- Main Window
- Agent Menu
- Routing Menu
- Bridge Menu
- Availability Menu
- RMON Menu
- Port Menu
- Stacking Menu

Main Window

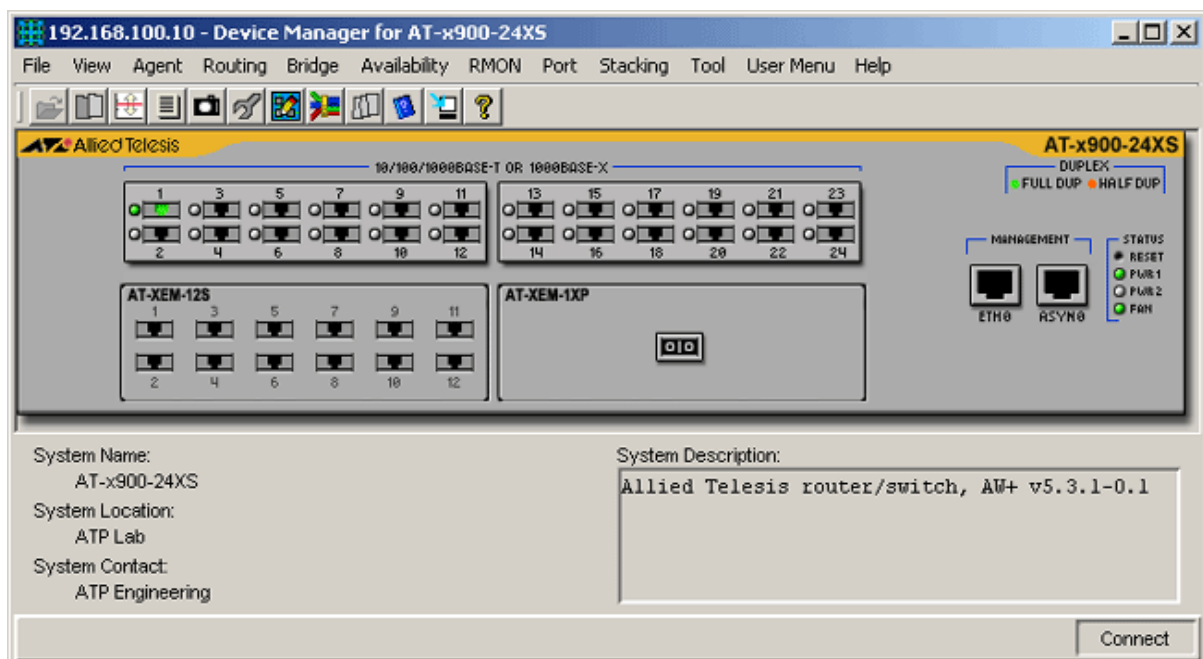

AT-x900-24XS

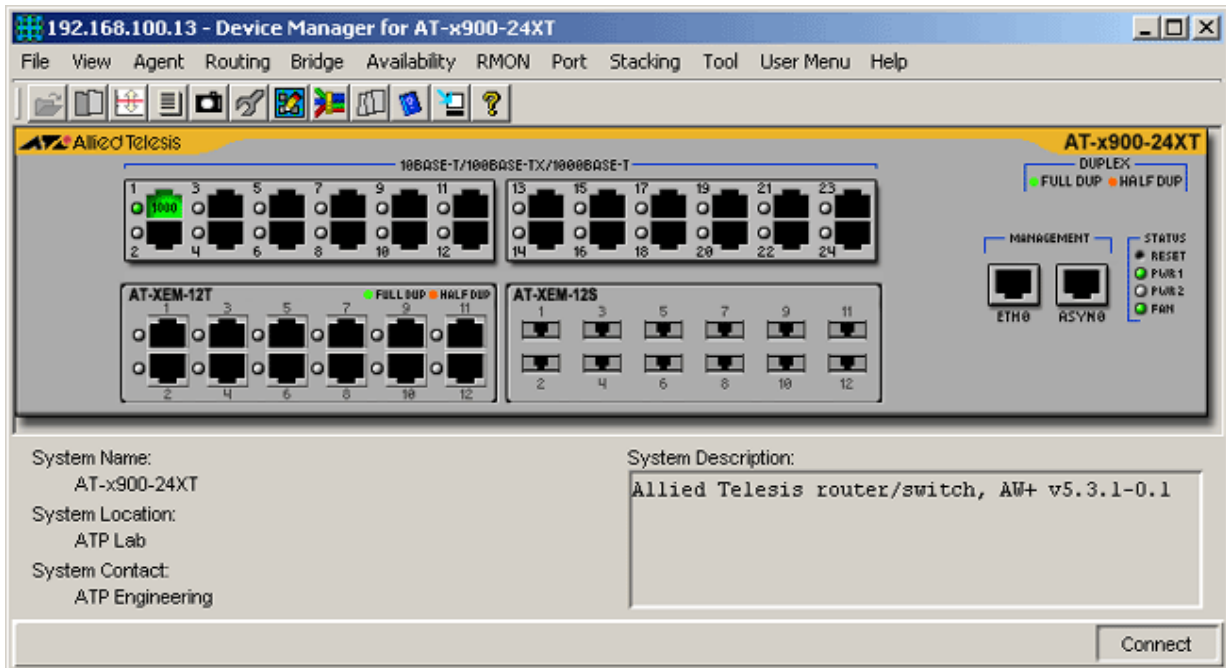

AT-x900-24XT

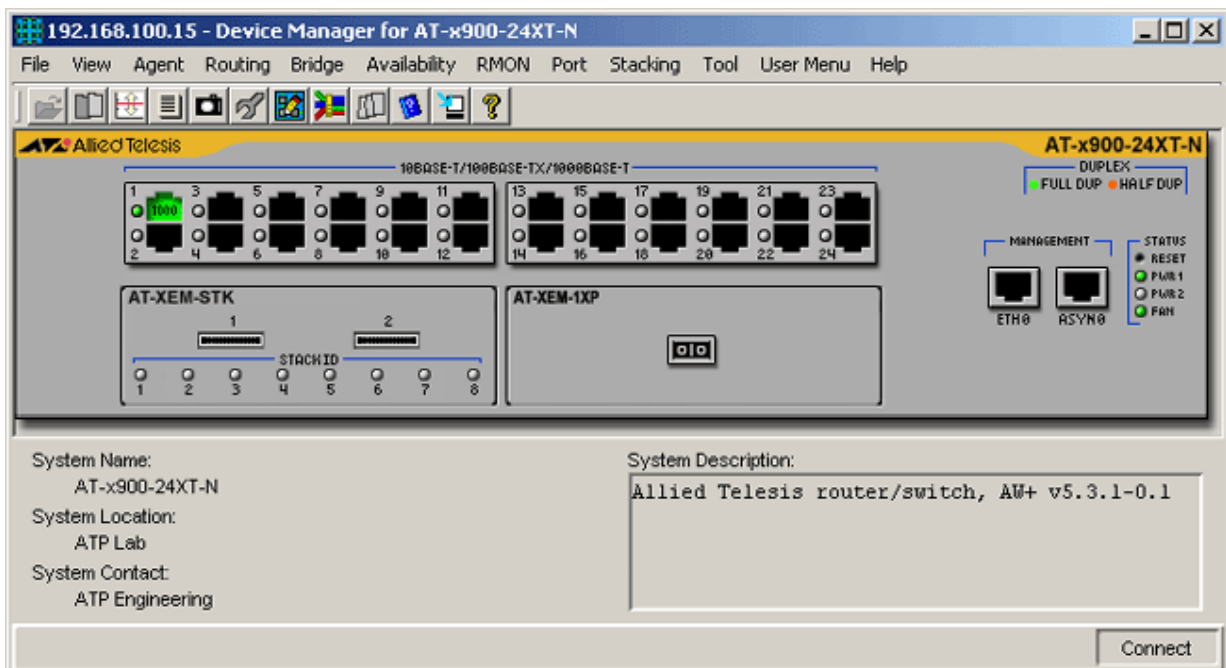

AT-x900-24XT-N

Device Manager LEDs for the AT-x900-24X Series

LED	State	Description
PWR 1	Green	The Power Supply Unit (PSU) is installed and functioning in the PSU bay 1.
	Gray	The Power Supply Unit (PSU) is either not installed or not functioning in the PSU bay 1.

Device Manager LEDs for the AT-x900-24X Series		
LED	State	Description
PWR 2	Green	The Power Supply Unit (PSU) is installed and functioning in the PSU bay 2.
	Gray	The Power Supply Unit (PSU) is either not installed or not functioning in the PSU bay 2.
FAN	Green	The Fan Module is installed and functioning in the PSU bay.
	Gray	The Fan Module is either not installed or not functioning in the PSU bay.
DUPLEX	Green	The port is operating at full duplex.
	Orange	The port is operating at half duplex.
STACK ID	Green	The stacked unit is either the Stacking Master or the Backup Master.
	Gray	The switch is set to standalone mode.
	Orange	The stacked unit is a slave switch.

Note - Please refer to Uplink Modules for the operations and behavior of the Expansion Modules installed on these devices.

Note - The current firmware version does not allow Device Manager to detect the presence or absence of an SFP module in any of the SFP slots. As a result, the SFP slots on the device image and uplink module image will always show SFP images regardless of whether or not SFP modules are physically present in the slots.

Note - The current firmware version does not allow Device Manager to detect the presence or absence of an XFP module in any of the XFP slots. As a result, the XFP slots on the uplink module image will always show XFP images regardless of whether or not XFP modules are physically present in the slots.

Note - When the Spanning Tree Status parameter is set to 'enabled', the current firmware version continues to return a value of 'forwarding' for the Port State parameter of blocking ports. As a result, blocking ports will remain green and will not turn to yellow.

Agent Menu

From the Agent menu, you can view and edit the system information for the switch, or log into the CLI using Telnet.

System Info
Standard

Displays basic system information, including system name, location, contact and description.

Note - Valid MIB Set values for the System Contact and System Location parameters are up to 255 characters. Attempting to enter values greater than the valid range will be accepted but values exceeding 255 characters will be truncated.

Note - Valid MIB Set values for the System Name parameter is up to 255 characters. However, values exceeding 64 characters will be truncated.

Note - The current firmware version allows the System Name parameter to be set to 'NULL'. However, attempting to set this parameter to value 'NULL' will set it to its default value 'awplus'.

Enterprise

CPU Utilization

Displays information about the CPU utilization over different periods of time.

Fan Speeds

Displays information about fans installed in the device that have their fan speeds monitored by environment monitoring hardware.

Voltage Rails

Displays information about voltage rails in the device that are monitored by environment monitoring hardware.

Temperature Sensors

Displays information about the temperature monitored by the temperature sensors in the device.

Power Supply Bays

Displays information about the Power Supply Bays in the system and info on any devices that are present.

Power Supply Bay Sensors

Displays information about device installed in the Power Supply Bay.

LED Faults

Displays information about the LEDs on the device.

Contact Details / Memory

Displays Contact Details information and Memory information of the device.

Host Resources

General System Info

Displays general information about the host resources.

Note - Device Manager does not handle objects of type OCTET STRING correctly. As a result, the Time and Date parameter will display a sequence of bytes in hexadecimal format instead of the actual date and time of day.

Note - The Time and Date, Initial Load Device and Initial Load Parameter parameters are implemented as 'read-only'.

Logical Storage Areas

Displays resource information about the storage devices.

Note - The current firmware version returns a "noSuchName" value for the Allocation Failures parameter.

Note - The Storage Size parameter is implemented as 'read-only'.

Devices

Displays resource information about the devices installed in the host.

Note - The current firmware version returns the value 'NULL' for the Device ID parameter.

Processors

Displays basic information about the processor installed in the host.

Note - Device Manager does not handle objects of type OCTET STRING correctly. As a result, the Firmware Product ID parameter will display a sequence of bytes in hexadecimal format instead of the actual integer value.

Running Software

Displays each distinct piece of software that is running or loaded into physical or virtual memory of the device.

Note - The current firmware version returns the value 'NULL' for the Run ID parameter.

Note - The Status parameter is implemented as 'read-only'.

Software Performance

Displays the CPU and Memory Software running performance of the device.

Host Info

Displays the host information of the device.

Hardware Info

Total Expansion Modules Installed

Displays the number of expansion modules installed in the device.

Installed Modules Info

Displays information about the expansion modules installed in the device.

Note - The current firmware version does not allow the Board Bay parameter to be configured. Attempting to configure this parameter to any valid value will result in the error "The error occurred with 'Set' operation. Error: gen error".

Firmware Info

Current Firmware

Displays information about the current software version installed in the device.

Note - Configuring the Save Current Software parameter to values greater than its valid range will be accepted but will cause the device to restart intermittently.

Note - The current firmware version allows the Save Current Software parameter to be set to a 'null' value. However, the Save Current Software parameter will always return 'saving (null)' value and will not be configurable unless the switch is restarted.

Note - The SNMP agent may take awhile to respond if the Save Current Software parameter has been set to 'saving'. When this happens, it may take a while for device information to be displayed in Device Manager.

Next Boot Firmware

Displays the version of the firmware that the device is currently set to boot from and its full path.

Backup Firmware

Displays the backup software version and its path in the device.

Software License Info

Base License

Displays information about the installed base software licenses on the device.

Installed Licenses

Displays information about the software licenses installed on the device.

Note - The current firmware version returns inconsistent values for the Index and Stack ID parameters.

Note - Configuring the Row Status parameter to 'destroy' as its value will result to an error message "The error occurred with 'Set' operation. Error: time out occurred". However, the value is still set successfully.

Features Info

Displays information about the feature licenses installed on the device.

Install New License

Allows the user to install a new license on the device.

Note - Configuring the Name and Key parameters to value 'NULL' will cause the device to restart intermittently.

Note - The SNMP agent may take awhile to respond if the Name and Key parameters have been set to value 'NULL'. When this happens, it may take a while for device information to be displayed in Device Manager.

File System

Standard

Displays the standard file system information of the device.

Note - Device Manager does not handle objects of type OCTET STRING correctly. As a result, the Last Full Backup Date and Last Partial Backup Date parameter will display a sequence of bytes in hexadecimal format instead of the actual date and time of day.

Note - The Last Full Backup Date and Last Partial Backup Date parameters are implemented as 'read-only'.

Enterprise

File Options Parameters

Displays information about the file options on the device.

File Information

Displays information about the files saved on the device.

Note - The current firmware version returns a 'noSuchName' value intermittently for the File Information parameter when using SNMPv1.

Note - The current firmware version does not return values for the File Size, File Creation Time and File Attributes parameters intermittently when using an SNMPv3 account.

File Operations

Allows user to perform copy, move and delete file operations on the device.

Note - The current firmware version allows the Copy Begin, Move Begin and Delete Begin parameters to be set to '1' even if the values set in the Source Stack ID and Destination Stack ID parameters are incorrect. However, copy, move or delete operation will not be successful.

SD Card

Displays information about the installed SD cards.

Config File Info

Device Configurations

Current Config

Allows the user to save and set the running configuration of the device to its flash.

Next Boot Config

Displays the full path of the configuration file to use the next time the device is rebooted.

Default Config

Displays the default config file info of the device.

GUI Configurations

Displays the latest GUI applet file residing in the root directory of flash that is applicable to the currently running system software.

CLI Servers

Displays information about CLI Servers.

Users

User Info

Displays the information about the users currently logged in the device.

User Config

Displays the information about the users configured in the local user database of the device.

NTP

Peers

Displays the NTP Peer Information on the device.

Note - The current firmware version does not allow the Row Status parameter to be set to 'active' as its value. Attempting to do so will result in the error message "The error occurred with 'Set' operation. Error: time out occurred".

Note - Valid MIB Set values for the Name Address parameter is from 1 to 256 characters. However, the current firmware version allows the user to enter values greater than the valid range.

Associations

Displays the NTP Association on the device.

NTP Info

Displays the peer index's next available value.

System Log

Log Entries

Displays information of the log entries on the device.

Note - The current firmware version returns a 'noSuchName' value intermittently for the Log Entries parameter when using SNMPv1.

Log Options

Displays the log options on the device.

Trigger

Trigger Info

Displays the trigger configuration information in the device.

Trigger Counters

Displays counters in activation of the triggers in the device.

Remote Ping

Ping Objects

Displays the maximum number of concurrent active ping requests.

Note - The Target Address Type parameter is implemented as 'read-only'.

Ping Control

Defines the Ping Control Table for providing, via SNMP, the capability of performing ping operations at a remote host.

Note - The current firmware version returns a 'noSuchName' value for the Owner Index and Test Name parameters.

Note - Device Manager does not handle MIB table with Read-Create access correctly. Attempting to set any parameters of this table will result in the error "The Error occurred with 'Set' operation.Error:NoSuchname".

Ping Results

Displays the results of the performed ping operations in the Ping Control table.

Note - Device Manager does not handle objects of type OCTET STRING correctly. As a result, the Target IP Address parameter will display a sequence of bytes in hexadecimal format instead of the actual IP address of the remote host.

Note - Device Manager does not handle objects of type OCTET STRING correctly. As a result, the Last Good Probe parameter will display a sequence of bytes in hexadecimal format instead of the actual date and time of day.

Ping Probe History Table

Displays ping probe history in performing ping operations.

Note - The current firmware version returns a 'noSuchName' value for the Ping Probe History Table parameters.

Restart Device

Initiates a restart on the switch.

Note - For devices that is set to standalone mode, while the Reset operation is in progress, error "The error with 'Set' operation. Error: time out occurred." will be displayed and should be ignored.

Telnet

Starts a Telnet connection to the switch.

WEB Browser

Connects to the switch's HTTP server.

Routing Menu

From the Routing menu, you can view and edit information about the switch's IP routing functions.

IP

Address Table

Standard

Displays the list of IP interfaces on the switch.

Note - The Re-assemble Max Size parameter is not applicable to the AT-x900-24X series (AlliedWare Plus) and should be ignored.

Additional Info

Displays the information of the IP Address of the device.

Note - Device Manager does not handle objects of type OCTET STRING correctly. As a result, the Address parameter will display a sequence of bytes in hexadecimal format instead of the actual IP address of the device.

Note - The current firmware version does not allow the Port Number and Assignment Type parameters to be configured.

Note - The current firmware version allows the user to enter up to 128 characters for the Label parameter but truncates entered values to 127 characters.

Note - Configuring Prefix Length parameter will result in the error message "The error occurred with 'Set' operation. Error: time out occurred." However, the new value is still set successfully.

Route Number

Displays the IP routing number on the switch.

Route Table

Displays the IP routing table on the switch.

Note - The current firmware version returns the value 'NULL' for the Routing Protocol MIB parameter.

Note - The following parameters are implemented as 'read-only':

- Destination Port Number
- Routing Type
- Routing Protocol MIB
- Next Hop AS Number
- Destination Metric 1
- Destination Metric 2
- Destination Metric 3
- Destination Metric 4
- Destination Metric 5
- Row Status

IP Statistics

Displays statistics about IP, such as the number of IP datagrams received.

Note - Valid MIB Set values for the Default TTL parameter should range from 1-255. However, the current firmware version does not allow this parameter to be set to '1' as its value. Attempting to set this parameter to '1' will result in the error message "The error occurred with 'Set' operation: time out occurred." Connection with the device will be lost and the only way to re-establish connection will be to perform a manual reset.

UDP

Listener Info

Displays UDP listener information.

UDP Statistics

Displays UDP statistics.

TCP

Connection Info

Displays TCP connection-specific information.

Note - The Connection Status parameter is implemented as 'read-only'.

TCP Statistics

Displays TCP statistics.

ICMP Statistics

Displays ICMP statistics.

DNS

DNS Server

Displays DNS server information.

Note - The current firmware version does not allow the Status parameter to be set to 'active' as its value. Attempting do so will result in the error message "The error occurred with 'Set' operation. Error: time out occurred".

DNS Client

Displays DNS Client information.

Bridge Menu

From the Bridge menu, you can view and edit bridge information such as the forwarding database and the spanning tree status.

Forwarding Database

Standard View

Displays the Forwarding Database table as returned by the device.

Note - The current firmware version returns the value "00 00 CD 00 00 00" for the Management MAC Address parameter of base port 11.

Enhanced View

Displays the Forwarding Database table on a per port basis. User can select a port or group of ports to view its corresponding Forwarding Database entries.

Discard/Aging Time Info

Displays information about the number of address entries that were learned but discarded for reasons such as lack of memory or the entry's aging timer.

Note - Valid MIB Set values for the Aging Time parameter is in the range [10-630] inclusive.

Note - Values entered for the Aging Time parameter must be multiples of 10. Values that are not multiples of 10 will be automatically rounded down to the nearest tens.

Spanning Tree Info

Displays spanning tree parameters such as priority and cost.

Statistics

Displays statistics about frames received/transmitted on the switch port.

Basic Bridge Info

Displays basic bridge information.

Bridge Port Info

Displays bridge port information.

Note - The current firmware version returns the value 'NULL' for the Circuit parameter.

802.1p

Device Capabilities

Displays the device capabilities information.

Traffic Class

Displays the bridge traffic class and received traffic class info.

Note - The Traffic Class Priority parameter is not applicable to AT-x900-24X series (AlliedWare Plus) and should be ignored.

Note - The Received Traffic Class parameter is implemented as 'read-only'.

Availability Menu

From the Availability menu, you can view the EPSR MIB.

EPSR

Displays the EPSR information of the device.

RMON Menu

From the RMON menu, you can view and edit the RMON MIB.

Statistics

Displays traffic statistics in the network segment attached to each port.

History Control Table

Displays the RMON History table.

Note - Device Manager does not handle MIB table with Read-Create access correctly. Attempting to set any parameters of this table will not be successful.

Alarm Table

Displays the RMON Alarm table.

Event Table

Displays the RMON Event table.

Event Log

Displays the RMON Event log.

Port Menu

From the Port menu, you can view and edit MIB information about the port.

Utilization

Displays the port's utilization information.

Interface Info

Standard

Displays high-capacity port statistics including received and transmitted unicast/multicast/broadcast packets on the port, link up/down trap and port speed.

Note - The following parameters are not applicable to the AT-x900-24X series (AlliedWare Plus) and should be ignored:

- Specific Media MIB
- Received Non Unicast Packets
- Transmitted Non Unicast Packets
- Transmitted Buffer Length

Note - Device Manager will not display the correct state of the ports and duplex LEDs if logged-on in SNMPv3 mode using a user account with no read access to the Interface Info parameters.

Additional Info

Displays port statistics such as the number of frames received and transmitted on the port, bytes received and transmitted on the port, and port status.

Note - The current firmware version returns a 'noSuchName' value for the following parameters:

- Received Bytes (HC)
- Received Unicast Packets (HC)
- Received Multicast Packets (HC)
- Received Broadcast Packets (HC)
- Transmitted Bytes (HC)
- Transmitted Unicast Packets (HC)
- Transmitted Multicast Packets (HC)
- Transmitted Broadcast Packets (HC)

Note - The Promiscuous Mode parameter is implemented as 'read-only'.

Note - The Counter Discontinuity Time parameter is not applicable to the AT-x900-24X series (AlliedWare Plus) and should be ignored.

Note - Valid MIB Set values for the Port Alias parameter is up to 64 characters. Attempting to enter values greater than the valid range will be accepted but values exceeding 64 characters will be truncated.

Error Statistics

Displays error statistics.

Note - The Ethernet Chipset parameter is not applicable to the AT-x900-24X series (AlliedWare Plus) and should be ignored.

Received Address

Displays the address for which the system will accept packets/frames on the particular interface.

Note - The Received Address parameter is not applicable to the AT-x900-24X series (AlliedWare Plus) and should be ignored

Note - The Received Address Status and Received Address Type parameters are implemented as 'read-only'.

Spanning Tree Info

Standard

Displays the port's spanning tree parameters.

Note - Valid MIB Set values for the Port Path Cost parameter is in the range [1-65535] inclusive.

Note - The current firmware version does not allow the Port parameter to be configured.

Additional Info

Displays additional information on the port's spanning tree parameters.

Note - The current firmware version does not allow the Protocol Migration parameter to be set to 'true'.

Note - The current firmware version does not allow the Point-to-Point Config parameter to be set to 'auto'.

Note - Valid MIB Set values for the Port Path Cost Config parameter is [1-200000000] inclusive. However, the current firmware version allows the user to set this parameter to '0' as its value and will automatically set the entered value to valid values.

MAC Control Pause

Displays information about the MAC Control Pause function on a single ethernet-like interface.

Note - The current firmware version returns a 'noSuchName' value for the Received Frames (HC) and Transmit Frames (HC) parameters.

Note - The PAUSE Config parameter is implemented as 'read-only'.

MAU Info

Displays interface-related MAU information for the port.

Note - The MAU Status and Default MAU Type parameters are implemented as 'read-only'.

Note - The MAU Type List parameter is not applicable to the AT-x900-24X series (AlliedWare Plus) and should be ignored.

Note - The Mau Type List Bits and HC False Carriers parameters are not applicable to the AT-x900-24X series (AlliedWare Plus) and should be ignored.

Note - The current firmware version returns the value 'NULL' for the MAU Type and Default MAU Type parameters.

MAU Negotiation Info

Displays the MAU's auto-negotiation settings and its status.

Note - The Administration Status and Restart parameters are implemented as 'read-only'.

Note - The Advertised Negotiation Capability parameter is not applicable to the AT-x900-24X series (AlliedWare Plus) and should be ignored.

Note - The Negotiation Capability, Advertised Negotiation Capability and Received Negotiation Capability parameters are not applicable to the AT-x900-24X series (AlliedWare Plus) and should be ignored.

Note - The following parameters are not applicable to the AT-x900-24X series (AlliedWare Plus) and should be ignored:

- Capability Bits
- Advertised Bits
- Received Bits
- Remote Fault Advertised
- Remote Fault Received

Aggregator Port List

Displays Link Aggregation Control information for every Aggregation Port associated with this device.

Note - The current firmware version returns a 'noSuchName' value for the Partner Administrative System ID and Partner Operational System ID parameters.

Note - The current firmware version does not allow the Actor Administrative Status and Partner Administrative Status parameter to be configured. Attempting to configure this parameter to any valid value will result in the error "The error occurred with 'Set' operation. Error: gen error".

Note - The current firmware version does not allow the following parameters to be set to '0'.

- Partner Administrative System Priority
- Partner Administrative Port
- Partner Administrative Port Priority

Enable

Enables the port.

Disable

Disables the port.

Stacking Menu

From the Stacking menu, you can view and edit the Stacking MIB.

Stack Status

Displays the stack status information of the device.

Stack Info

Displays information about the stacked devices.

SwitchBlade x908

This section describes Device Manager menus and operations specific to the SwitchBlade x908 Advanced Layer 3 Modular Switch.

Topics:

- Main Window
- Agent Menu
- Routing Menu
- Bridge Menu
- Availability Menu
- RMON Menu
- Port Menu
- Stacking Menu

Main Window

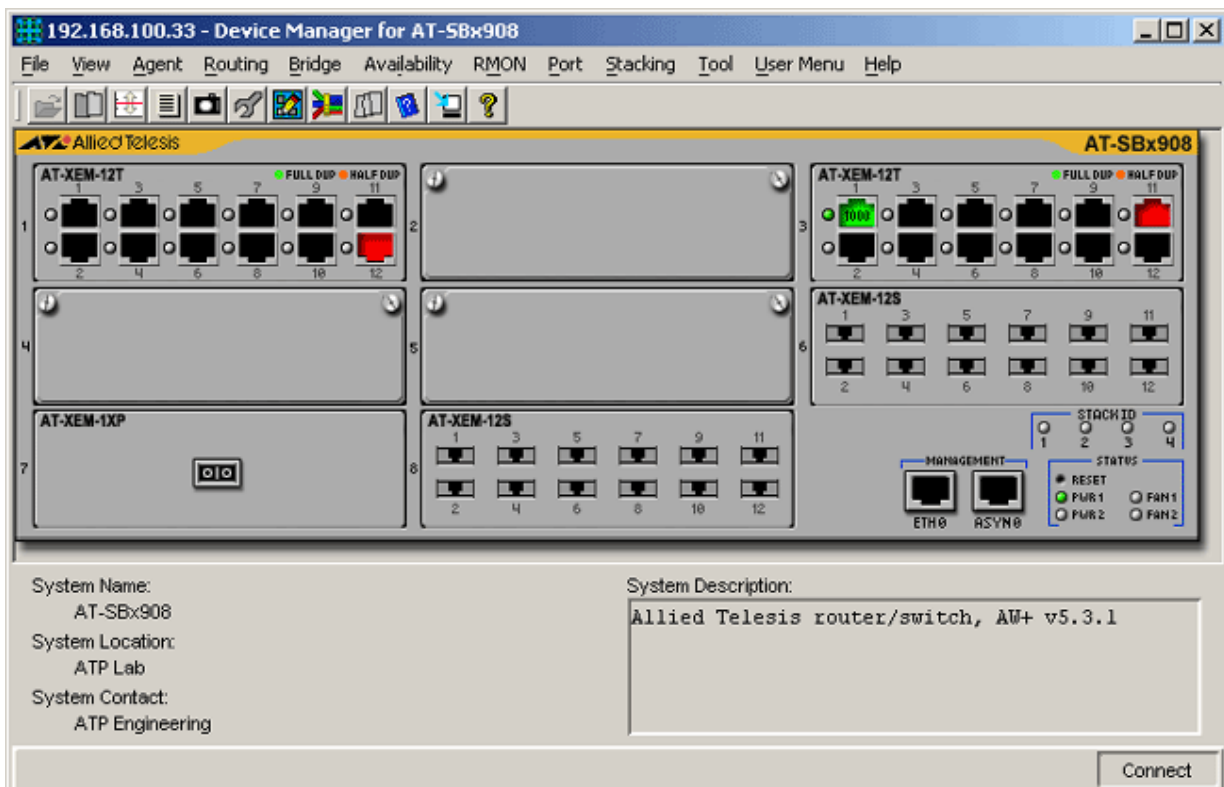

SwitchBlade x908

Device Manager LEDs for the SwitchBlade x908		
LED	State	Description
PWR 1	Green	The Power Supply Unit (PSU) is installed and functioning in the PSU bay 1.
	Gray	The Power Supply Unit (PSU) is either not installed or not functioning in the PSU bay 1.
PWR 2	Green	The Power Supply Unit (PSU) is installed and functioning in the PSU bay 2.
	Gray	The Power Supply Unit (PSU) is either not installed or not functioning in the PSU bay 2.
FAN 1	Green	The fan module is installed and functioning in the Fan bay 1.
	Gray	The fan module is either not installed or not functioning in the Fan bay 1.
FAN 2	Green	The fan module is installed and functioning in the Fan bay 2.
	Gray	The fan module is either not installed or not functioning in the Fan bay 2.
STACK ID	Green	The stacked unit is either the Stacking Master or the Backup Master.
	Gray	The switch is set to standalone mode.
	Orange	The stacked unit is a slave switch.

Note - Please refer to Uplink Modules for the operations and behavior of the Expansion Modules installed on the chassis.

Note - The current firmware version does not allow Device Manager to support the FAN LEDs.

Note - The current firmware version does not allow Device Manager to detect the presence or absence of an SFP module in any of the SFP slots. As a result, the SFP slots on the uplink module image will always show SFP images regardless of whether or not SFP modules are physically present in the slots.

Note - The current firmware version does not allow Device Manager to detect the presence or absence of an XFP module in any of the XFP slots. As a result, the XFP slots on the uplink module image will always show XFP images regardless of whether or not XFP modules are physically present in the slots.

Note - When the Spanning Tree Status parameter is set to 'enabled', the current firmware version continues to return a value of 'forwarding' for the Port State parameter of blocking ports. As a result, blocking ports will remain green and will not turn to yellow.

Agent Menu

From the Agent menu, you can view and edit the system information for the switch, or log into the CLI using Telnet.

System Info

Standard

Displays basic system information, including system name, location, contact and description.

Note - Valid MIB Set values for the System Contact and System Location parameters are up to 255 characters. Attempting to enter values greater than the valid range will be accepted but values exceeding 255 characters will be truncated.

Note - Valid MIB Set values for the System Name parameter is up to 255 characters. However, values exceeding 64 characters will be truncated.

Note - The current firmware version allows the System Name parameter to be set to 'NULL'. However, attempting to set this parameter to value 'NULL' will set it to its default value 'awplus'.

Enterprise

CPU Utilization

Displays information about the CPU utilization over different periods of time.

Fan Speeds

Displays information about fans installed in the device that have their fan speeds monitored by environment monitoring hardware.

Voltage Rails

Displays information about voltage rails in the device that are monitored by environment monitoring hardware.

Temperature Sensors

Displays information about the temperature monitored by the temperature sensors in the device.

Power Supply Bays

Displays information about the Power Supply Bays in the system and info on any devices that are present.

Power Supply Bay Sensors

Displays information about device installed in the Power Supply Bay.

LED Faults

Displays information about the LEDs on the device.

Contact Details / Memory

Displays Contact Details information and Memory information of the device.

Host Resources

General System Info

Displays general information about the host resources.

Note - Device Manager does not handle objects of type OCTET STRING correctly. As a result, the Time and Date parameter will display a sequence of bytes in hexadecimal format instead of the actual date and time of day.

Note - The Time and Date, Initial Load Device and Initial Load Parameter parameters are implemented as 'read-only'.

Logical Storage Areas

Displays resource information about the storage devices.

Note - The current firmware version returns a "noSuchName" value for the Allocation Failures parameter.

Note - The Storage Size parameter is implemented as 'read-only'.

Devices

Displays resource information about the devices installed in the host.

Note - The current firmware version returns the value 'NULL' for the Device ID parameter.

Processors

Displays basic information about the processor installed in the host.

Note - Device Manager does not handle objects of type OCTET STRING correctly. As a result, the Firmware Product ID parameter will display a sequence of bytes in hexadecimal format instead of the actual integer value.

Running Software

Displays each distinct piece of software that is running or loaded into physical or virtual memory of the device.

Note - The current firmware version returns the value 'NULL' for the Run ID parameter.

Note - The Status parameter is implemented as 'read-only'.

Software Performance

Displays the CPU and Memory Software running performance of the device.

Host Info

Displays the host information of the device.

Hardware Info

Total Expansion Modules Installed

Displays the number of expansion modules installed in the device.

Installed Modules Info

Displays information about the expansion modules installed in the device.

Note - The current firmware version does not allow the Board Bay parameter to be configured. Attempting to configure this parameter to any valid value will result in the error "The error occurred with 'Set' operation. Error: gen error".

Firmware Info

Current Firmware

Displays information about the current software version installed in the device.

Note - Configuring the Save Current Software parameter to values greater than its valid range will be accepted but will cause the device to restart intermittently.

Note - The current firmware version allows the Save Current Software parameter to be set to a 'null' value. However, the Save Current Software parameter will always return 'saving (null)' value and will not be configurable unless the switch is restarted.

Note - The SNMP agent may take awhile to respond if the Save Current Software parameter has been set to 'saving'. When this happens, it may take a while for device information to be displayed in Device Manager.

Next Boot Firmware

Displays the version of the firmware that the device is currently set to boot from and its full path.

Backup Firmware

Displays the backup software version and its path in the device.

Software License Info

Base License

Displays information about the installed base software licenses on the device.

Installed Licenses

Displays information about the software licenses installed on the device.

Note - The current firmware version returns inconsistent values for the Index and Stack ID parameters.

Note - Configuring the Row Status parameter to 'destroy' as its value will result to an error message "The error occurred with 'Set' operation. Error: time out occurred". However, the value is still set successfully.

Features Info

Displays information about the feature licenses installed on the device.

Install New License

Allows the user to install a new license on the device.

Note - Configuring the Name and Key parameters to value 'NULL' will cause the device to restart intermittently.

Note - The SNMP agent may take awhile to respond if the Name and Key parameters have been set to value 'NULL'. When this happens, it may take a while for device information to be displayed in Device Manager.

File System

Standard

Displays the standard file system information of the device.

Note - Device Manager does not handle objects of type OCTET STRING correctly. As a result, the Last Full Backup Date and Last Partial Backup Date parameter will display a sequence of bytes in hexadecimal format instead of the actual date and time of day.

Note - The Last Full Backup Date and Last Partial Backup Date parameters are implemented as 'read-only'.

Enterprise

File Options Parameters

Displays information about the file options on the device.

File Information

Displays information about the files saved on the device.

Note - The current firmware version returns a 'noSuchName' value intermittently for the File Information parameter when using SNMPv1.

Note - The current firmware version does not return values for the File Size, File Creation Time and File Attributes parameters intermittently when using an SNMPv3 account.

File Operations

Allows user to perform copy, move and delete file operations on the device.

Note - The current firmware version allows the Copy Begin, Move Begin and Delete Begin parameters to be set to '1' even if the values set in the Source

Stack ID and Destination Stack ID parameters are incorrect. However, copy, move or delete operation will not be successful.

SD Card

Displays information about the installed SD cards.

Config File Info

Device Configurations

Current Config

Allows the user to save and set the running configuration of the device to its flash.

Next Boot Config

Displays the full path of the configuration file to use the next time the device is rebooted.

Default Config

Displays the default config file info of the device.

GUI Configurations

Displays the latest GUI applet file residing in the root directory of flash that is applicable to the currently running system software.

CLI Servers

Displays information about CLI Servers.

Users

User Info

Displays the information about the users currently logged in the device.

User Config

Displays the information about the users configured in the local user database of the device.

NTP

Peers

Displays the NTP Peer Information on the device.

Note - The current firmware version does not allow the Row Status parameter to be set to 'active' as its value. Attempting to do so will result in the error message "The error occurred with 'Set' operation. Error: time out occurred".

Note - Valid MIB Set values for the Name Address parameter is from 1 to 256 characters. However, the current firmware version allows the user to enter values greater than the valid range.

Associations

Displays the NTP Association on the device.

NTP Info

Displays the peer index's next available value.

System Log

Log Entries

Displays information of the log entries on the device.

Note - The current firmware version returns a 'noSuchName' value intermittently for the Log Entries parameter when using SNMPv1.

Log Options

Displays the log options on the device.

Trigger

Trigger Info

Displays the trigger configuration information in the device.

Trigger Counters

Displays counters in activation of the triggers in the device.

Remote Ping

Ping Objects

Displays the maximum number of concurrent active ping requests.

Note - The Target Address Type parameter is implemented as 'read-only'.

Ping Control

Defines the Ping Control Table for providing, via SNMP, the capability of performing ping operations at a remote host.

Note - The current firmware version returns a 'noSuchName' value for the Owner Index and Test Name parameters.

Note - Device Manager does not handle MIB table with Read-Create access correctly. Attempting to set any parameters of this table will result in the error "The Error occurred with 'Set' operation.Error:NoSuchname".

Ping Results

Displays the results of the performed ping operations in the Ping Control table.

Note - Device Manager does not handle objects of type OCTET STRING correctly. As a result, the Target IP Address parameter will display a sequence of bytes in hexadecimal format instead of the actual IP address of the remote host.

Note - Device Manager does not handle objects of type OCTET STRING correctly. As a result, the Last Good Probe parameter will display a sequence of bytes in hexadecimal format instead of the actual date and time of day.

Ping Probe History Table

Displays ping probe history in performing ping operations.

Note - The current firmware version returns a 'noSuchName' value for the Ping Probe History Table parameters.

Restart Device

Initiates a restart on the switch.

Note - For devices that is set to standalone mode, while the Reset operation is in progress, error "The error with 'Set' operation. Error: time out occurred." will be displayed and should be ignored.

Telnet

Starts a Telnet connection to the switch.

WEB Browser

Connects to the switch's HTTP server.

Routing Menu

From the Routing menu, you can view and edit information about the switch's IP routing functions.

IP

Address Table

Standard

Displays the list of IP interfaces on the switch.

Note - The Re-assemble Max Size parameter is not applicable to the SwitchBlade x908 series and should be ignored.

Additional Info

Displays the information of the IP Address of the device.

Note - Device Manager does not handle objects of type OCTET STRING correctly. As a result, the Address parameter will display a sequence of bytes in hexadecimal format instead of the actual IP address of the device.

Note - The current firmware version does not allow the Port Number and Assignment Type parameters to be configured.

Note - The current firmware version allows the user to enter up to 128 characters for the Label parameter but truncates entered values to 127 characters.

Note - Configuring Prefix Length parameter will result in the error message "The error occurred with 'Set' operation. Error: time out occurred."
However, the new value is still set successfully.

Route Number

Displays the IP routing number on the switch.

Route Table

Displays the IP routing table on the switch.

Note - The current firmware version returns the value 'NULL' for the Routing Protocol MIB parameter.

Note - The following parameters are implemented as 'read-only':

- Destination Port Number
- Routing Type
- Routing Protocol MIB
- Next Hop AS Number
- Destination Metric 1
- Destination Metric 2
- Destination Metric 3
- Destination Metric 4
- Destination Metric 5
- Row Status

IP Statistics

Displays statistics about IP, such as the number of IP datagrams received.

Note - Valid MIB Set values for the Default TTL parameter should range from 1-255. However, the current firmware version does not allow this parameter to be set to '1' as its value. Attempting to set this parameter to '1' will result in the error message "The error occurred with 'Set' operation: time out occurred." Connection with the device will be lost and the only way to re-establish connection will be to perform a manual reset.

UDP

Listener Info

Displays UDP listener information.

UDP Statistics

Displays UDP statistics.

TCP

Connection Info

Displays TCP connection-specific information.

Note - The Connection Status parameter is implemented as 'read-only'.

TCP Statistics

Displays TCP statistics.

ICMP Statistics

Displays ICMP statistics.

DNS

DNS Server

Displays DNS server information.

Note - The current firmware version does not allow the Status parameter to be set to 'active' as its value. Attempting do so will result in the error message "The error occurred with 'Set' operation. Error: time out occurred".

DNS Client

Displays DNS Client information.

Bridge Menu

From the Bridge menu, you can view and edit bridge information such as the forwarding database and the spanning tree status.

Forwarding Database

Standard View

Displays the Forwarding Database table as returned by the device.

Note - The current firmware version returns the value "00 00 CD 00 00 00" for the Management MAC Address parameter of the following ports:

- port 11 of XEM-12T
- port 12 of XEM-12S
- port 01 of XEM-1XP

This only applies when the XEM module is inserted in Bay 1.

Enhanced View

Displays the Forwarding Database table on a per port basis. User can select a port or group of ports to view its corresponding Forwarding Database entries.

Discard/Aging Time Info

Displays information about the number of address entries that were learned but discarded for reasons such as lack of memory or the entry's aging timer.

Note - Valid MIB Set values for the Aging Time parameter is in the range [10-630] inclusive.

Note - Values entered for the Aging Time parameter must be multiples of 10. Values that are not multiples of 10 will be automatically rounded down to the nearest tens.

Spanning Tree Info

Displays spanning tree parameters such as priority and cost.

Statistics

Displays statistics about frames received/transmitted on the switch port.

Basic Bridge Info

Displays basic bridge information.

Bridge Port Info

Displays bridge port information.

Note - The current firmware version returns the value 'NULL' for the Circuit parameter.

802.1p

Device Capabilities

Displays the device capabilities information.

Traffic Class

Displays the bridge traffic class and received traffic class info.

Note - The Traffic Class Priority parameter is not applicable to the SwitchBlade x908 series and should be ignored.

Note - The Received Traffic Class parameter is implemented as 'read-only'.

Availability Menu

From the Availability menu, you can view the EPSR MIB.

EPSR

Displays the EPSR information of the device.

RMON Menu

From the RMON menu, you can view and edit the RMON MIB.

Statistics

Displays traffic statistics in the network segment attached to each port.

History Control Table

Displays the RMON History table.

Note - Device Manager does not handle MIB table with Read-Create access correctly. Attempting to set any parameters of this table will not be successful.

Alarm Table

Displays the RMON Alarm table.

Event Table

Displays the RMON Event table.

Event Log

Displays the RMON Event log.

Port Menu

From the Port menu, you can view and edit MIB information about the port.

Utilization

Displays the port's utilization information.

Interface Info

Standard

Displays high-capacity port statistics including received and transmitted unicast/multicast/broadcast packets on the port, link up/down trap and port speed.

Note - The following parameters are not applicable to the SwitchBlade x908 series and should be ignored:

- Specific Media MIB
- Received Non Unicast Packets
- Transmitted Non Unicast Packets
- Transmitted Buffer Length

Note - Device Manager will not display the correct state of the ports and duplex LEDs if logged-on in SNMPv3 mode using a user account with no read access to the Interface Info parameters.

Additional Info

Displays port statistics such as the number of frames received and transmitted on the port, bytes received and transmitted on the port, and port status.

Note - The current firmware version returns a 'noSuchName' value for the following parameters:

- Received Bytes (HC)
- Received Unicast Packets (HC)
- Received Multicast Packets (HC)
- Received Broadcast Packets (HC)
- Transmitted Bytes (HC)
- Transmitted Unicast Packets (HC)
- Transmitted Multicast Packets (HC)
- Transmitted Broadcast Packets (HC)

Note - The Promiscuous Mode parameter is implemented as 'read-only'.

Note - The Counter Discontinuity Time parameter is not applicable to the SwitchBlade x908 series and should be ignored.

Note - Valid MIB Set values for the Port Alias parameter is up to 64 characters. Attempting to enter values greater than the valid range will be accepted but values exceeding 64 characters will be truncated.

Error Statistics

Displays error statistics.

Note - The Ethernet Chipset parameter is not applicable to the SwitchBlade x908 series and should be ignored.

Received Address

Displays the address for which the system will accept packets/frames on the particular interface.

Note - The Received Address parameter is not applicable to the SwitchBlade x908 series and should be ignored.

Note - The Received Address Status and Received Address Type parameters are implemented as 'read-only'.

Spanning Tree Info

Standard

Displays the port's spanning tree parameters.

Note - Valid MIB Set values for the Port Path Cost parameter is in the range [1-65535] inclusive.

Note - The current firmware version does not allow the Port parameter to be configured.

Additional Info

Displays additional information on the port's spanning tree parameters.

Note - The current firmware version does not allow the Protocol Migration parameter to be set to 'true'.

Note - The current firmware version does not allow the Point-to-Point Config parameter to be set to 'auto'.

Note - Valid MIB Set values for the Port Path Cost Config parameter is [1-200000000] inclusive. However, the current firmware version allows the user to set this parameter to '0' as its value and will automatically set the entered value to valid values.

MAC Control Pause

Displays information about the MAC Control Pause function on a single ethernet-like interface.

Note - The current firmware version returns a 'noSuchName' value for the Received Frames (HC) and Transmit Frames (HC) parameters.

Note - The PAUSE Config parameter is implemented as 'read-only'.

MAU Info

Displays interface-related MAU information for the port.

Note - The MAU Status and Default MAU Type parameters are implemented as 'read-only'.

Note - The MAU Type List parameter is not applicable to the SwitchBlade x908 series and should be ignored.

Note - The Mau Type List Bits and HC False Carriers parameters are not applicable to the SwitchBlade x908 series and should be ignored.

Note - The current firmware version returns the value 'NULL' for the MAU Type and Default MAU Type parameters.

MAU Negotiation Info

Displays the MAU's auto-negotiation settings and its status.

Note - The Administration Status and Restart parameters are implemented as 'read-only'.

Note - The Advertised Negotiation Capability parameter is not applicable to the SwitchBlade x908 series and should be ignored.

Note - The Negotiation Capability, Advertised Negotiation Capability and Received Negotiation Capability parameters are not applicable to the SwitchBlade x908 series and should be ignored.

Note - The following parameters are not applicable to the SwitchBlade x908 series and should be ignored:

- Capability Bits
- Advertised Bits
- Received Bits
- Remote Fault Advertised
- Remote Fault Received

Aggregator Port List

Displays Link Aggregation Control information for every Aggregation Port associated with this device.

Note - The current firmware version returns a 'noSuchName' value for the Partner Administrative System ID and Partner Operational System ID parameters.

Note - The current firmware version does not allow the Actor Administrative Status and Partner Administrative Status parameter to be configured. Attempting to configure this parameter to any valid value will result in the error "The error occurred with 'Set' operation. Error: gen error".

Note - The current firmware version does not allow the following parameters to be set to '0'.

- Partner Administrative System Priority
- Partner Administrative Port
- Partner Administrative Port Priority

Enable

Enables the port.

Disable

Disables the port.

Stacking Menu

From the Stacking menu, you can view and edit the Stacking MIB.

Stack Status

Displays the stack status information of the device.

Stack Info

Displays information about the stacked devices.

Note - The current firmware version returns 'xemStk' value for the Active Hardware parameter regardless of whether the AT-XEM-STK expansion module on the front panel or the fixed stacking connectors on the rear of the chassis is being used.

SwitchBlade x908

Media Converters

Converteon Series

This section describes Device Manager menus and operations specific to the Converteon Series.

Topics:

- Main Window
- Agent Menu
- Status Menu
- OAM Menu

Main Window

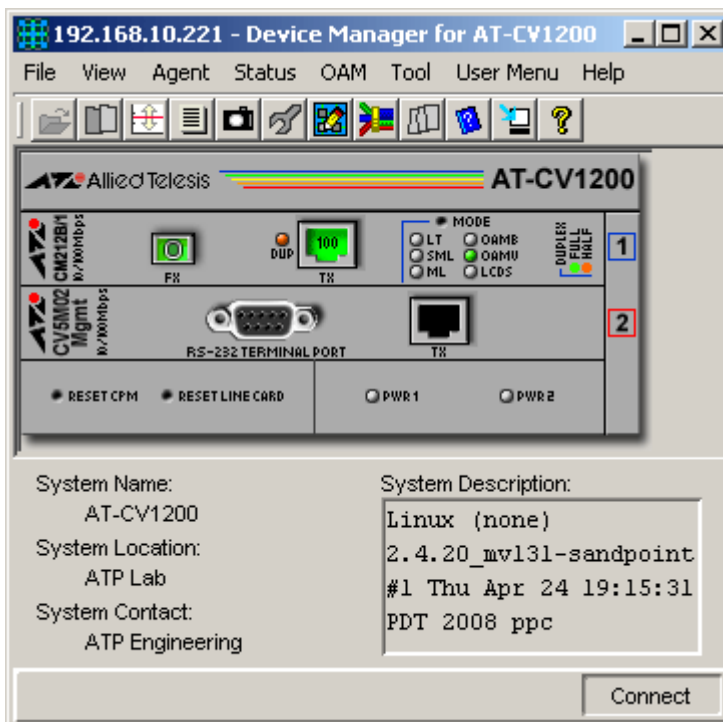

AT-CV1200

Note - While the Reset operation is in progress, error "The error with 'Set' operation. Error: time out occurred." will be displayed and should be ignored.

Note - The current firmware version does not allow Device Manager to support the PWR LEDs.

Note - AT-CV5M01: Resetting the line card also resets the CPM.

Note - Using an SNMP v3 account that has a NO-READ VACM setting, a 'noSuchName' or 'noSuchObject' error may be displayed.

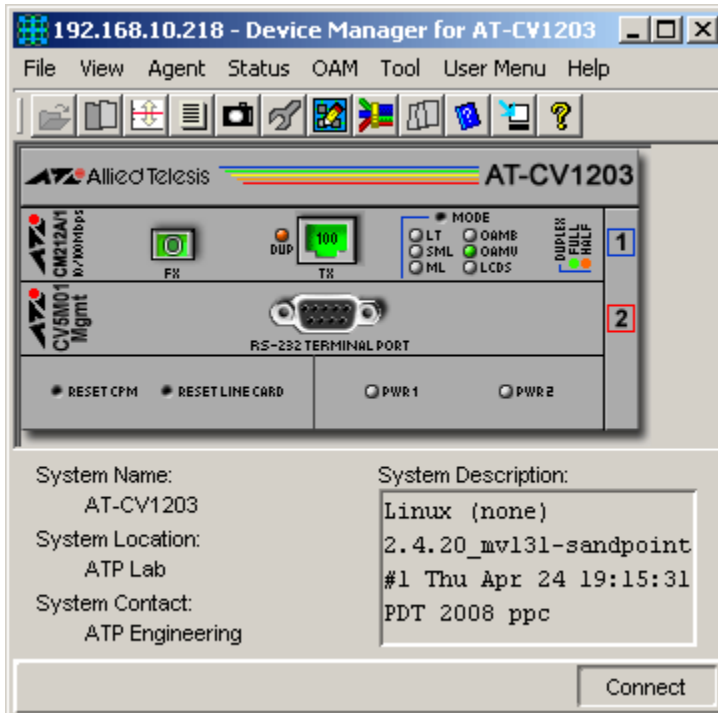

AT-CV1203

Note - While the Reset operation is in progress, error "The error with 'Set' operation. Error: time out occurred." will be displayed and should be ignored.

Note - The current firmware version does not allow Device Manager to support the PWR LEDs.

Note - AT-CV5M01: Resetting the line card also resets the CPM.

Note - Using an SNMP v3 account that has a NO-READ VACM setting, a 'noSuchName' or 'noSuchObject' error may be displayed.

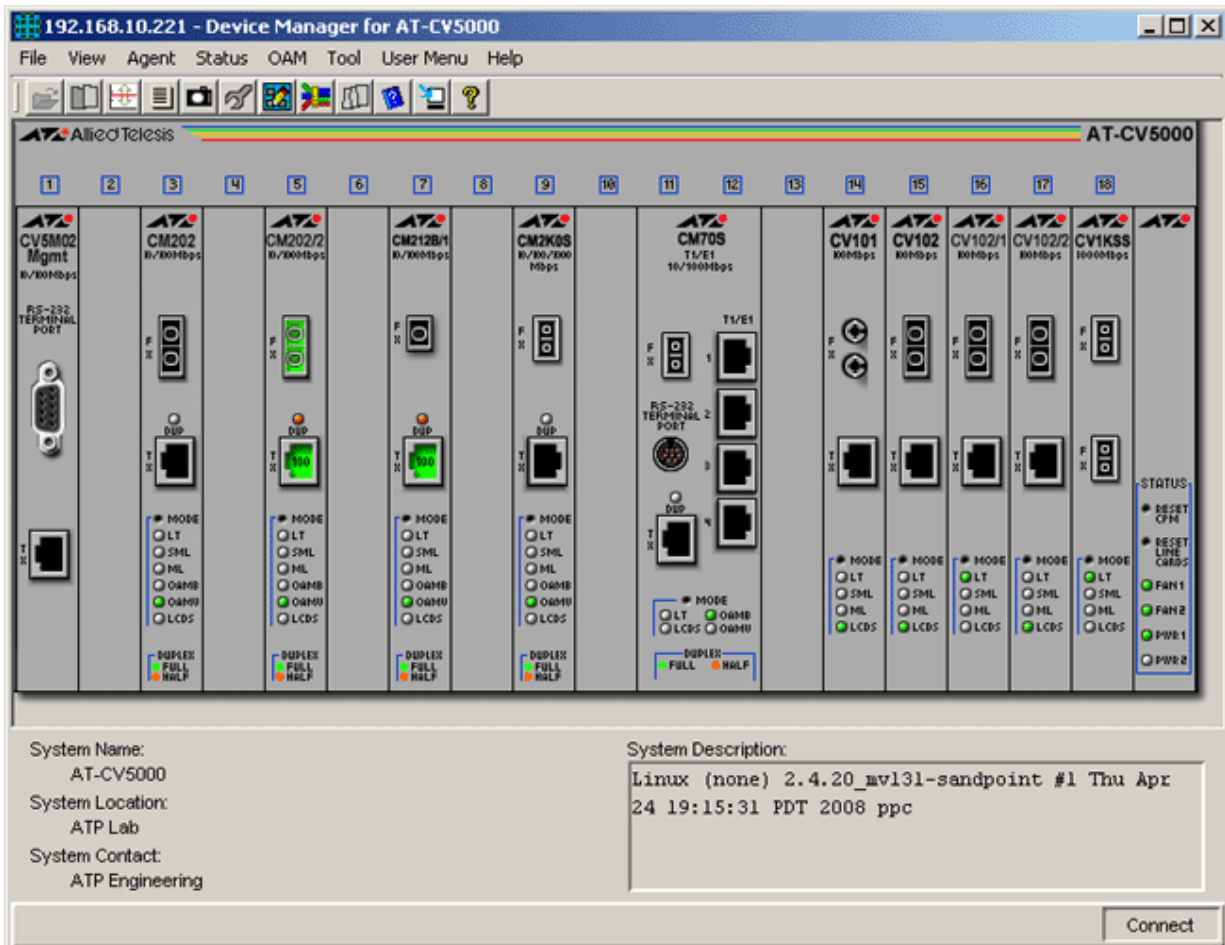

AT-CV5000

Device Manager LEDs for Converteon Chassis

LED	State	Description
PWR1	Green	Power supply 1 is installed and power is on.
	Gray	Power supply 1 is not installed or it is installed but not powered on.
PWR2	Green	Power supply 2 is installed and power is on.
	Gray	Power supply 2 is not installed or it is installed but not powered on.
FAN1 (AT-CV5000)	Green	FAN 1 is installed and power is on.
	Gray	FAN 1 is not installed or it is installed but not powered on.
FAN2 (AT-CV5000)	Green	FAN 2 is installed and power is on.
	Gray	FAN 2 is not installed or it is installed but not powered on.

Note - Please refer to Converteon Series Modules for the operations and behavior of the modules installed on the chassis.

Note - Using an SNMP v3 account that has a NO-READ VACM setting, a 'noSuchName' or 'noSuchObject' error may be displayed.

Note - While the Reset operation is in progress, error "The error with 'Set' operation. Error: time out occurred." will be displayed and should be ignored.

Agent Menu

From the Agent Menu, you can view and edit the system information for the chassis, or log into the CLI using Telnet.

System Info

Displays basic system information, including system name, location, contact and description.

Note - The System Contact and System Name parameters accept inputs of up to 39 characters only while the System Location parameter accepts up to 38. Input values that exceed these limits will be automatically truncated.

Network Info

Displays network-related information such as the addresses of the default gateway and the TRAP Destination.

System Config

Displays common management information.

Note - The Temperature Threshold parameter is not applicable to the AT-CV1200 and should be ignored.

The following submenu options will only be available when AT-CV5M02 Management module is installed:

General Config

Displays the system's general configurations.

System Date and Time

Displays the configuration about the device's date, time and Network Time Protocol.

Firmware Info

Displays information about the software release currently loaded in the device and installed modules.

System Log

Displays information and configuration about the device's system logs.

Diagnostics

Displays the device's software version, fan speed and fan temperature.

Reset

Resets the device.

Telnet

Starts a Telnet connection to the chassis.

The following submenu option will only be available when AT-CV5M02 Management module is installed:

WEB Browser

Starts a WEB browser session to the chassis.

Status Menu

From the Status Menu, you can view information about Converteon Series Modules installed on the chassis.

Module Info

Displays the basic module configuration information of the device. Options to view all/per module information are displayed.

Note - The Module Name parameter serves as the slot name. As such, any value specified for this parameter will be retained even if the line card occupying the slot is removed or replaced.

Note - Setting the Module Reset parameter of media converter line cards to 'yes' will not reset the line cards.

Note - The Module Reset parameter always displays the value '???(0)'.

Note - The Module Operation Mode parameter of CPMs always displays '???(0)'.

Note - AT-CV5M01: The current firmware version does not allow the Module Name parameter to be configured.

Port Info

Displays the port configurable parameters. Options to view all/per module information are displayed.

Note - AT-CV5M01: The current firmware version returns a 'noSuchName' value for the Port Flow Control parameter.

Note - AT-CV5M01: The value of the Port Mode and Port Duplex Status parameters automatically changes to 'manual' and 'half duplex' respectively when the value of its Port Speed parameter is changed from '100Mbps' to '10Mbps'.

Note - AT-CV5M01: The current firmware version does not allow Device Manager to display the TX port values configured via Telnet.

Note - AT-CV5M01: The current firmware version does not allow Port Mode, Port Duplex Status and Port MDIX parameters to be configured if the current Port Speed parameter is set to '100Mbps'.

Port Statistics

Displays the basic port statistics configuration information. Options to view all/per module information are displayed.

Remote Line Card Info

Displays the Remote Line Card information of the AT-CMxx series line cards.

Remote Module Info

Displays the module info of the line cards.

Note - AT-CV5M01: The current firmware version does not allow the Remote Local Module Name parameter to be configured.

Note - The current firmware version does not allow the Remote Module Name parameter to be configured.

Note - AT-CV5M01: The current firmware version does not display the Remote Module Name, Remote Module Type and Remote Module Software Version parameters correctly.

Note - AT-CV5M01: The current firmware version returns a 'noSuchName' value for the Remote Module Software Version parameter.

Remote Port Info

Displays the remote port information of the line cards.

Note - AT-CV5M01: The current firmware version returns a 'noSuchName' value for the Remote Port MDIX and Remote Port Flow Control parameters.

Note - AT-CV5M01: The current firmware version does not allow Remote Port Mode, Remote Port Duplex and Remote Port Speed parameters of TX type of ports to be configured. Attempting to configure these parameters other than its current values will result in the error message: "The error occurred with 'Set' operation. Error: time out occurred."

Note - AT-CV5M01: The current firmware version does not allow Remote Ingress Rate Limit and Remote Egress Rate Limit parameters to be configured. Attempting to configure these parameters other than its current values will result in the error message: "The error occurred with 'Set' operation. Error: time out occurred."

Remote SFP Info

Displays the remote SFP of the AT-CM2K0s and AT-CM70S line cards.

Remote Port Statistics Info

Displays the remote port statistics information of the line cards.

Note - The current firmware version returns a 'noSuchName' value for the Remote Data Transmitted parameter.

OAM Menu

From the OAM Menu, you can view information about OAM capabilities of the device.

OAM Config

Displays information about the device's administration status, max OAM PDU size and configuration revision.

Note - Device Manager does not handle objects of type BITS correctly. As a result, the Functions Supported parameter will display binary data instead of human-readable data.

Note - AT-CV5M01: The current firmware version does not allow the Max OAM PDU Size parameter to be configured.

OAM Statistics

Displays information about the device's transmitted and received frames, received and transmitted loopback OAMPDU's and received and transmitted variable responses.

OAM Peer Info

Displays information about the device's peer mac address, peer mode and peer vendor info.

Note - The current firmware version does not return any value for the Peer Functions Supported and Peer Vendor OUI parameters.

Loopback

Displays information on how to control loopback state and the status of the loopback function.

Note - The current firmware version does not allow Loopback Command parameter to be configured.

Converteon Series Modules

This section describes the modules supported by Device Manager. If modules are installed on the AT-CV5000 or AT-CV1200 chassis at the time Device Manager is called, they will be displayed in their corresponding slots on the chassis image.

- AT-CV5M01
- AT-CV5M02
- AT-CM201
- AT-CM202 and AT-CM202/x
- AT-CM212x/I
- AT-CM2K0S
- AT-CM70S
- AT-CV10x
- AT-CV1KSS

AT-CV5M01



Management Module: 10/100TX to 100FX (100m)

AT-CV5M02



Enhanced Management Module: 10/100TX to 100FX (100m)

AT-CM201



10/100TX to 100FX (ST, 2km, MM)

LED	State	Description
DUP	Green	The port is operating in full-duplex mode.
	Orange	The port is operating in half-duplex mode.
LT	Green	Link Test is enabled
SML	Green	Smart Missing Link is enabled
ML	Green	Missing Link is enabled
OAMB	Green	OAM Bypass is enabled
OAMV	Green	OAM Visible is enabled
LCDS	Green	Line Card Dip Switch is enabled

Note - The Module Name parameter always displays 'yyyyyyyy' as its default value when not yet configured.

Note - AT-CV5M01: The current firmware version does not allow the Port Mode parameter of FX type of ports to be configured. Attempting to configure this parameter other than its current Port Mode value will result in the error message: "noSuchName."

AT-CM202 and AT-CM202/x



AT-CM202: 10/100TX to 100FX (SC, 2km, MM)



AT-CM202/1: 10/100TX to 100FX (SC, 15km, MM)



AT-CM202/2: 10/100TX to 100FX (SC, 40km, MM)

LED	State	Description
DUP	Green	The port is operating in full-duplex mode.
	Orange	The port is operating in half-duplex mode.
LT	Green	Link Test is enabled
SML	Green	Smart Missing Link is enabled

LED	State	Description
ML	Green	Missing Link is enabled
OAMB	Green	OAM Bypass is enabled
OAMV	Green	OAM Visible is enabled
LCDS	Green	Line Card Dip Switch is enabled

Note - The Module Name parameter always displays 'yyyyyyy' as its default value when not yet configured.

Note - AT-CV5M01: The current firmware version does not allow the Port Mode parameter of FX type of ports to be configured. Attempting to configure this parameter other than its current Port Mode value will result in the error message: "noSuchName."

Port Info

Note - The value of the Port Mode parameter of a port with an established link automatically changes to 'auto' when the settings of the port to which it is connected are modified.

Note - The value of the Port Speed parameter of a port with an established link automatically changes to '10Mbps' when the value of its Port Mode parameter is changed from 'auto' to 'manual'.

AT-CM212x/I



AT-CM212A/I: 10/100TX to 100FX (SC, 15km, SM)



AT-CM212B/I: 10/100TX to 100FX (SC, 15km, SM)

LED	State	Description
DUP	Green	The port is operating in full-duplex mode.
	Orange	The port is operating in half-duplex mode.
LT	Green	Link Test is enabled
SML	Green	Smart Missing Link is enabled
ML	Green	Missing Link is enabled

LED	State	Description
OAMB	Green	OAM Bypass is enabled
OAMV	Green	OAM Visible is enabled
LCDS	Green	Line Card Dip Switch is enabled

Note - The Module Name parameter always displays 'yyyyyyyy' as its default value when not yet configured.

Note - AT-CV5M01: The current firmware version does not allow the Port Mode parameter of FX type of ports to be configured. Attempting to configure this parameter other than its current Port Mode value will result in the error message: "noSuchName."

Port Info

Note - The value of the Port Mode parameter of a port with an established link automatically changes to 'auto' when the settings of the port to which it is connected are modified.

Note - The value of the Port Speed parameter of a port with an established link automatically changes to '10Mbps' when the value of its Port Mode parameter is changed from 'auto' to 'manual'.

AT-CM2K0S



10/100/1000T to SFP

LED	State	Description
DUP	Green	The port is operating in full-duplex mode.
	Orange	The port is operating in half-duplex mode.
LT	Green	Link Test is enabled
SML	Green	Smart Missing Link is enabled
ML	Green	Missing Link is enabled
OAMB	Green	OAM Bypass is enabled
OAMV	Green	OAM Visible is enabled
LCDS	Green	Line Card Dip Switch is enabled

Note - The Module Name parameter always displays 'yyyyyyyy' as its default value when not

yet configured.

Note - AT-CV5M01: The current firmware version does not allow the Port Mode parameter of FX type of ports to be configured. Attempting to configure this parameter other than its current Port Mode value will result in the error message: "noSuchName."

Port Info

Note - The value of the Port Mode parameter of a port with an established link automatically changes to 'auto' when the settings of the port to which it is connected are modified.

Note - The value of the Port Speed parameter of a port with an established link automatically changes to '10Mbps' when the value of its Port Mode parameter is changed from 'auto' to 'manual'.

Note - The current firmware version does not allow the Port Ingress Rate Limit and Port Egress Rate Limit parameters to be configured.

Note - AT-CV5M01: The current firmware version does not allow Port Speed and Port Duplex Status parameters to be set to '1Gbps' and 'unknown' values respectively.

AT-CM70S



4 x T1/E1 + 10/100TX over SFP-based fiber.

LED	State	Description
DUP	Green	The port is operating in full-duplex mode.
	Orange	The port is operating in half-duplex mode.

LED	State	Description
LT	Green	Link Test is enabled
OAMB	Green	OAM Bypass is enabled
OAMV	Green	OAM Visible is enabled
LCDS	Green	Line Card Dip Switch is enabled

Note - The current firmware version will not allow remote port connection on the RJ-45 port if the SFP port is set to disabled.

Note - The Module Name parameter always displays 'yyyyyyyy' as its default value when not yet configured.

Note - AT-CV5M01: The current firmware version does not allow the Port Mode parameter of FX type of ports to be configured. Attempting to configure this parameter other than its current Port Mode value will result in the error message: "noSuchName."

Remote Line Card Info

Note - Even if the current firmware version allows the Remote Port Mode parameter to be configured to certain values, this parameter should not be configured for the 100Base-FX port.

Port Info

Note - The value of the Port Speed and Port Duplex parameters of a port with an established link automatically changes to '10Mbps' and 'half duplex' when the value of its Port Mode parameter is changed from 'auto' to 'manual'.

Note - The current firmware version does not allow Device Manager to configure or display information on the T1/E1 port of the AT-CM70S.

Note - The value of the Port Speed and Port Duplex parameters of a port with an established link automatically changes to '10Mbps' and 'half duplex' when the value of its Port Mode parameter is changed from 'auto' to 'manual'.

Note - The current firmware version does not allow the Port Ingress Rate Limit and Port Egress Rate Limit parameters to be configured.

Context Menu

Note - Selecting the Telnet option in the RS-232 Terminal Port Context Menu of the AT-CM70S will establish a Telnet session to the AT-CV5M01 management module.

AT-CV10x



AT-CV101: 10/100TX to 100FX (ST, 2km, MM)



AT-CV102: 10/100TX to 100FX (SC, 2km, MM)



AT-CV102/1: 10/100TX to 100FX (SC, 15km, SM)



AT-CV102/2: 10/100TX to 100FX (SC, 40km, SM)

LED	State	Description
LT	Green	Link Test is enabled
SML	Green	Smart Missing Link is enabled
ML	Green	Missing Link is enabled
LCDS	Green	Line Card Dip Switch is enabled

Module Info

Note - The current firmware version does not return the correct value for the Module MAC Address parameter.

Note - AT-CV5M01: Configuring the Module Operation Mode parameter will result in the error message: "The error occurred with 'Set' operation. Error: time out occurred".

Port Info

Note - The current firmware version does not allow any of the parameters under this table to be configured.

AT-CVIKSS



1000X to 1000X SFP

LED	State	Description
LT	Green	Link Test is enabled
SML	Green	Smart Missing Link is enabled
ML	Green	Missing Link is enabled
LCDS	Green	Line Card Dip Switch is enabled

Note - The current firmware version does not allow Device Manager to detect the presence or absence of an SFP module in any of the SFP slots. As a result, the SFP slots on the device image will always show SFP images regardless of whether or not SFP modules are physically present in the slots.

Note - The SFP port images will always be fiber optic ports even if the actual SFP modules inserted in the SFP slots have copper ports. This is because the current firmware version does not allow Device Manager to identify the port type of SFP modules inserted in the SFP slots.

Module Info

Note - The current firmware version does not return any value for the Module Revision parameter.

Note - The current firmware version does not return the correct value for the Module MAC Address parameter.

Note - AT-CV5M01: Configuring the Module Operation Mode parameter will result in the error message: "The error occurred with 'Set' operation. Error: time out occurred".

Port Info

Note - The current firmware version does not allow any of the parameters under this table to be configured.

AT-MCF2000 Media Converter

This section describes Device Manager menus and operations specific to the AT-MCF2000 Media Converter.

Topics:

- Main Window
- Agent Menu
- Status Menu

Main Window

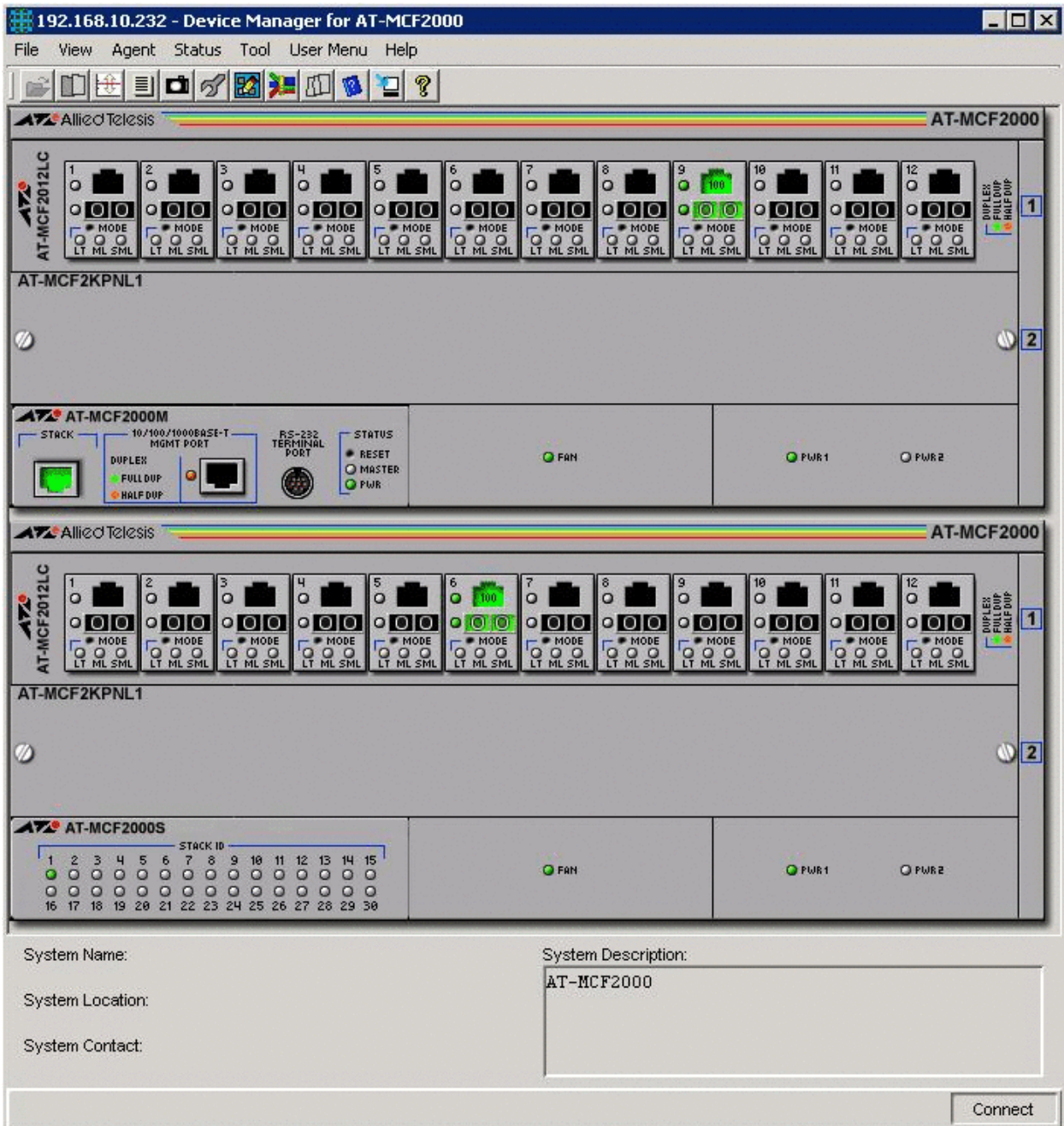

AT-MCF2000

Device Manager LEDs for AT-MCF2000 Chassis

LED	State	Description
PWR1	Green	Power Supply 1 is installed and power is on.
	Gray	Power Supply 1 is not installed or it is installed but not powered on.
PWR2	Green	Power supply 2 is installed and power is on.

Device Manager LEDs for AT-MCF2000 Chassis		
LED	State	Description
	Gray	Power supply 2 is not installed or it is installed but not powered on.
FAN	Green	FAN is installed and power is on.
	Gray	FAN is not installed or it is installed but not powered on.

Note - Please refer to AT-MCF2000 Modules for the operation and behavior of the modules installed on the chassis.

Note - While the Reset Chassis operation is in progress, error "The error occurred with 'Set' operation. Error: time out occurred." will be displayed and port image of the line card (if inserted) will appear red and should be ignored.

Agent Menu

From the Agent Menu, you can view and edit the system information for the chassis, or log into the CLI using Telnet.

System Info

Displays basic system information, including system name, location, contact and description.

Note - Valid MIB Set values for the System Name, System Contact and System Location parameters are in the range [0-25] inclusive. However, the current firmware version accepts inputs of up to 40 characters.

Device Info

Displays device-related information such as the software version and bootloader version of the modules.

Chassis Info

Displays chassis information, including MAC Address and Serial Number.

Management Module Info

Displays Management Module's information, including software and bootloader versions.

Note - The Module Location parameter always displays the value '???(N)'.

Note - The current firmware version is unable to display values for the following parameters when the Management Module Chassis ID is set to 31:

- Management Module Name
- Management Module Type
- Management Module 1.2V Status
- Management Module 1.8V Status
- Management Module 2.5V Status
- Management Module 3.3V Status
- Management Module 12.0V Status
- Management Module Temperature
- Management Module Software Version
- Management Module Bootloader Version
- Management Module Serial Number
- Management Module Hardware Revision

Note - The current firmware version does not return valid values for the following parameters when the Management Module Chassis ID is set to 31:

- Module Location
- Management Module Status
- Management Module Present Status
- Management Module Temperature Threshold
- Reset Management Module

Module Info

Displays Module's information, including software and bootloader version of linecards.

Note - The current firmware version will not return any information on the status of the reset line card operation. As a result, Device Manager will not display any indication that the reset line card operation was successful or not.

Note - The Module Location parameter always displays the value '???(N)'.

Power and Fan Module Slot Info

Displays Power and Fan Module's information including the module's serial number and status.

Network Info

Displays network-related information such as the addresses of the default gateway and the TRAP Destination.

System Config

Displays the device's system variables.

General Config

Displays the device's system configuration.

Note - Valid MIB Set values for the System Name, System Contact and System Location parameters are in the range [0-25] inclusive. However, the current firmware version accepts inputs of up to 40 characters.

System Date and Time

Displays the system's Date, Time and Network Time Protocol configuration.

Note - Configuring the NTP Mode parameter to "Enable" will result in the error message: "The error occurred with 'Set' operation. Error: time out occurred." but the NTP Mode will still be successfully set.

Note - Configuring the NTP Server parameter will result in the error message: "The error occurred with 'Set' operation. Error: time out occurred." but the NTP Server address will still be successfully set.

System Log

Displays the system's log information.

Reset

Resets the chassis and/or modules.

Telnet

Starts a Telnet connection to the chassis.

Status Menu

From the Status Menu, you can view information about AT-MCF2000 Modules installed on the chassis.

Port Info

Displays the port configurable parameters. Options to view all/module 1/module 2 information are displayed including the configurable parameters for the management port.

Management Port Info

Displays the Management Module's port information.

Note - Configuring the following parameters to any valid value will result in the error message: "The error occurred with 'Set' operation. Error: time out occurred." but values will still be successfully set.

- Management Port Auto Negotiation
- Management Port Speed
- Management Port MDIX

Note - The current firmware version does not allow the Port Ingress Rate Limit and Port Egress Rate Limit parameters to be configured. Attempting to set these parameters to valid values will result in the error message: " The error occurred with 'Set' operation. Error: bad value."

Module Info

Displays the Linecard's port information.

Note - The current firmware version has irregular GETNEXT behavior. As a result, Device Manager will display Module Info parameters in a single column table instead of displaying it per port or per interface.

Note - The Module Location parameter always displays the value '???(N)?'.

Note - The current firmware version does not allow the Port Ingress Rate Limit and Port Egress Rate Limit parameters to be configured. Attempting to set these parameters to valid values will result in the error message: " The error occurred with 'Set' operation. Error: bad value."

Port Interface Info

Displays the basic port interface configuration information. Options to view all/module 1/module 2 information are displayed.

Note - The current firmware version does not return the correct value of the Port Name parameter when configured. Attempting to check this parameter in CLI will show that the parameter was successfully set.

Note - The Module Location parameter always displays the value '???(N)'.

Note - Valid MIB Set values for the Port Operation Mode parameter are "smart missing link", "missing link" and "link test". However, the current firmware version allows the Port Operation Mode parameter to be set to "oam bypass" or "oam visible".

Note - The current firmware version returns inconsistent values on the Port Operation Mode parameter.

AT-MCF2000 Modules

This section describes the modules supported by Device Manager. If modules are installed on the AT-MCF2000 chassis at the time Device Manager is called, they will be displayed in their corresponding slots on the chassis image.

- AT-MCF2000M
- AT-MCF2000S
- AT-MCF2012LC
- AT-MCF2012LC/I

AT-MCF2000M

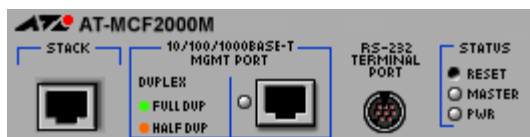

Management Module : 10/100/1000BASE-T

LED	State	Description
MASTER	Green	Management module chassis ID is set to 0.
	Gray	Management module chassis ID is set to 31.
DUPLEX	Green	The port is operating in full-duplex mode.
	Orange	The port is operating in half-duplex mode.
PWR	Green	The power supply is on.

AT-MCF2000S

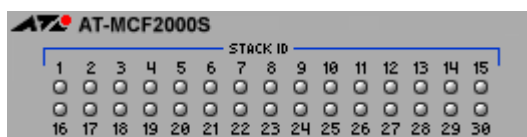

Stacking Module

LED	State	Description
STACK ID	Green	Indicates that a connection has been established for the stack module. The number that corresponds to the LED is the stack ID.
	Gray	Connection with another Stack port has not been established.

AT-MCF2012LC

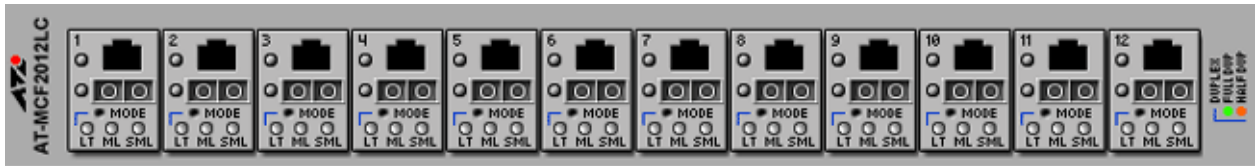

10/100Base-TX to 100BaseFX (LC, 2km, MM)

LED	State	Description
DUPLEX	Green	The port is operating in full-duplex mode.
	Orange	The port is operating in half-duplex mode.
LT	Green	Link Test is enabled
ML	Green	Missing Link is enabled
SML	Green	Smart Missing Link is enabled

Context Menu

Note - Valid MIB Set values for the Port Operation Mode parameter are "smart missing link", "missing link" and "link test". However, the current firmware version allows the Port Operation Mode parameter to be set to "oam bypass" or "oam visible".

Note - The current firmware version does not allow the Port Ingress Rate Limit and Port Egress Rate Limit parameters to be configured. Attempting to set these parameters to valid values will result in the error message: "The error occurred with 'Set' operation. Error: bad value.".

Note - The current firmware version returns inconsistent values on the Port Operation Mode parameter.

AT-MCF2012LC/I

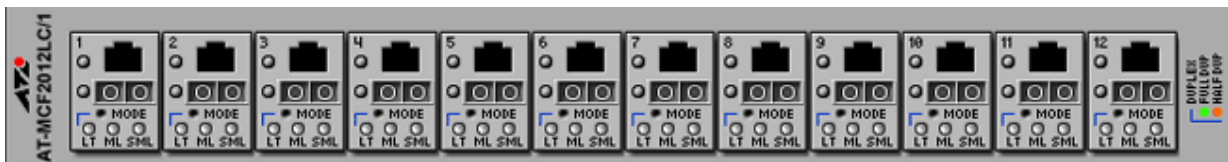

10/100Base-TX to 100BaseFX (LC, 20km, SM)

LED	State	Description
DUPLEX	Green	The port is operating in full-duplex mode.
	Orange	The port is operating in half-duplex mode.

LED	State	Description
LT	Green	Link Test is enabled
ML	Green	Missing Link is enabled
SML	Green	Smart Missing Link is enabled

Context Menu

Note - The current firmware version returns a string of special characters as its value for the Bootloader Version parameter.

Note - Valid MIB Set values for the Port Operation Mode parameter are "smart missing link", "missing link" and "link test". However, the current firmware version allows the Port Operation Mode parameter to be set to "oam bypass" or "oam visible".

Note - The current firmware version does not allow the Port Ingress Rate Limit and Port Egress Rate Limit parameters to be configured. Attempting to set these parameters to valid values will result in the error message: " The error occurred with 'Set' operation. Error: bad value.".

Note - The current firmware version returns inconsistent values on the Port Operation Mode parameter.

PowerBlade

This section describes Device Manager menus and operations specific to the AT-PBC18 chassis.

Topics:

- Main Window
- Agent Menu
- Status Menu

Main Window

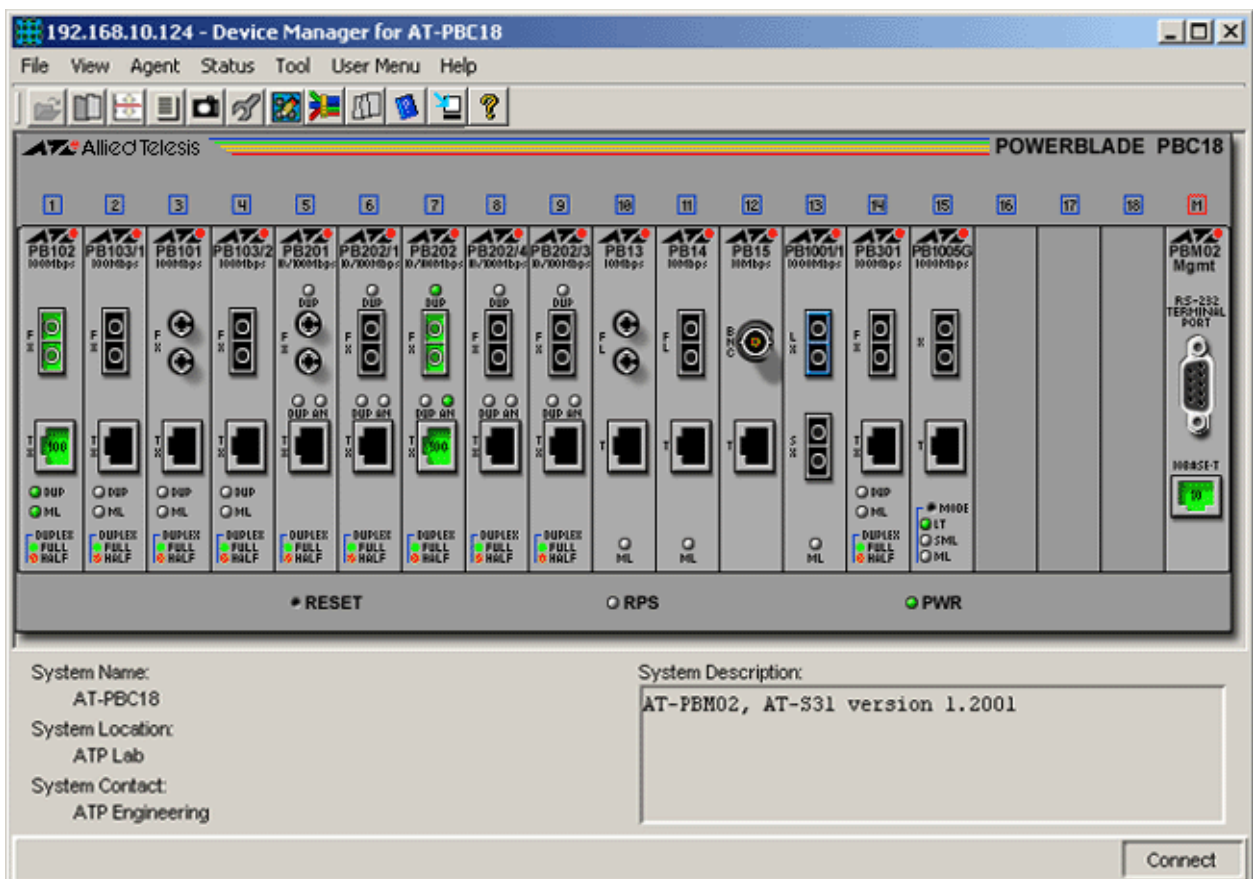

AT-PBC18

Device Manager LEDs for AT-PBM02 Management Module		
LED	State	Description
PWR	Green	The main power supply is installed and power is on.
	Gray	The main power supply is not installed or it is installed but not powered on.
RPS	Green	The optional redundant power supply is installed and power is on.
	Gray	The optional redundant power supply is not installed or it is installed but not powered on.

Note - The current firmware version does not allow Device Manager to support the Reset button.

Note - Please refer to PowerBlade Modules for the operations and behavior of the modules installed on the chassis.

Agent Menu

From the Agent Menu, you can view and edit the system information for the chassis, or log into the CLI using Telnet.

System Info

Displays basic system information, including system name, location, contact and description.

Note - Device Manager allows the user to enter more than 20 characters for the System Name parameter. However, doing so will result in the following error message: "The error occurred with 'Set' operation. Error: bad value."

System Date and Time

Displays system configuration for system date and time.

Network Info

Displays network-related information such as the addresses of the default gateway and the agents.

Note -The Default Domain Name parameter returns unrecognizable characters.

FAN Info

Displays fan speed.

Management Module Temperature

Displays the actual temperature of the management module.

Chassis Temperature

Displays the actual temperature of the chassis.

Power Info

Displays power supply voltage information.

Battery Voltage

Displays the battery voltage information.

Omega

Displays Omega management interface information, including time-out and port status (RS-232 and 10Base-T).

Telnet

Starts a Telnet connection to the chassis.

Status Menu

From the Status Menu, you can view and edit information about PowerBlade Modules installed on the chassis. Options to view all/per module information are displayed.

Note - The current firmware version does not allow the Module Name parameter to be set to NULL. Attempting to set this parameter to NULL will only set it to its default value.

Note - The Module Type parameter returns 0 for the management module (19), main power supply (20), and optional redundant power supply (21).

Note - The same set of parameters is displayed for each module regardless of whether or not each parameter is applicable to the module.



PowerBlade

PowerBlade Modules

This section describes the modules supported by Device Manager. If modules are installed on the PowerBlade chassis at the time Device Manager is called, they will be displayed in their corresponding slots on the chassis image.

- AT-PB10 Series Media Converter Modules
- AT-PB100 Series Media Converter Modules
- AT-PB200 Series Switch Modules
- AT-PB300 Series Media Converter Modules
- AT-PB1000 Series Media Converter Modules

AT-PB10 Series Media Converter Modules





PB13		PB14		PB15	
					
LED	State	Description			
ML	Green	The Missing Link feature is enabled			

Note - The Port A Mode and the Port B Mode parameters return 'not supported' for these modules.

Note - Active ports on PB13 and PB14 do not turn red when disabled using the Omega interface.

Note - The Link Test parameter of PB15 has a fixed value of 'hardware-link-test' and cannot be modified.

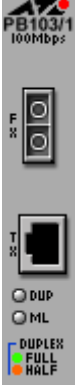
AT-PB100 Series Media Converter Modules





PB101		PB102		PB103/1		PB103/2	
							
LED	State	Description					
DUP	Green	The media converter is operating in full-duplex mode.					
	Gray	The media converter is operating in half-duplex mode.					
ML	Green	The Missing Link feature is enabled.					

Note - The Port A Mode parameter for these modules has a fixed value of 'full' and cannot be modified.

Note - The current firmware version does not allow the Port B Mode parameter to be set to 'full' from the default value of 'half'. Likewise, it cannot be set to 'half' if it was set to 'full' using the Omega interface.

Note - Expect the DUP LED to be green when it should be gray and vice-versa when the Port B Mode parameter is set to 'auto'. This is because the current firmware version is unable to provide information on the negotiated mode for Port B.

AT-PB200 Series Switch Modules

PB201	PB202	PB202/1	PB202/3	PB202/4
				
LED	State	Description		
DUP	Green	The media converter is operating in full-duplex mode.		
	Gray	The media converter is operating in half-duplex mode.		
AN	Green	The 10/100Base-TX port is auto-negotiating.		

Note - Connection cannot be established between a 10/100Base-TX port on an AT-PB200 series module that is configured to auto-negotiate and a 10/100Base-TX port on another AT-PB200 series module that is configured to operate at 100 full/half duplex.

Note -The current firmware version allows the Port A Speed parameter to be set to '10M' even if Port A is only capable of operating at a speed of 100Mbps.

Note -The current firmware version allows the Port A Mode parameter to be set to 'auto' even if Port A is not capable of auto-negotiation.

Note -When the Port B Mode parameter is set to 'auto', the current firmware version is unable to provide information on the negotiated speed and mode for Port B. As a result, the speed reflected on the port image may be a '10' when it should really be '100' and vice-versa. Also, expect the DUP LED to be gray when it should really be green or orange.

AT-PB300 Series Media Converter Modules

PB301		
		
LED	State	Description
DUP	Green	The media converter is operating in full-duplex mode.
	Gray	The media converter is operating in half-duplex mode.
ML	Green	The Missing Link feature is enabled.



Note - Port A is displayed as an SC connector instead of a VF-45 connector.

Note - The Port A Mode parameter for this module has a fixed value of 'full' and cannot be modified.

Note - The current firmware version does not allow the Port B Mode parameter to be set to 'full' from the default value of 'half'. Likewise, it cannot be set to 'half' if it was set to 'full' using the Omega interface.

Note - Expect the DUP LED to be green when it should be orange and vice-versa when the Port B Mode parameter is set to 'auto'. This is because the current firmware version is unable to provide information on the negotiated mode for Port B.

AT-PBI000 Series Media Converter Modules

PBI001/I		PBI001/3		PBI005G	
					
LED	State	Description			
LT	Green	Link Test is enabled			
SML	Green	Smart Missing Link is enabled			
ML	Green	Missing Link is enabled			

Note - Smart Missing Link is only supported on the AT-PBI005G module. However, the current firmware version allows the Link Test parameter of the AT-PBI001/I and AT-PBI001/3 modules to be set to 'smart-missing-link'.

Note - The Port A Mode and the Port B Mode parameters return 'not supported' for these modules.

Note - A GBIC image is always visible on the GBIC slot of the PBI005G module image even if there is no GBIC physically present in the slot.

PowerBlade Modules

Expansion Gateways

Port Interface Cards

This section describes the Port Interface Cards supported in Device Manager.

If one of these PICs is installed in a PIC bay or in a Network Service Module (NSM) of a device, it will be displayed in the PIC bay image or NSM image of the device panel in the main window.

AT-AR020



LED	State	Description
B DATA	Green	HDLC packets are being exchanged between the switch or router and another end system device (normally another switch or router) over any of the B (data) channels.
	Gray	No packet transmission over B channel.

AT-AR021

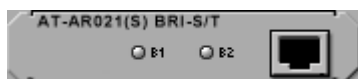

LED	State	Description
B1 and B2	Green	For permanent circuits, HDLC packets are being exchanged between the switch or router and another end system device (normally another switch or router) over any of the B channel. For on-demand ISDN, there is a call up over the respective B-channel.
	Gray	No packet/data transmission over B-channel.

AT-AR022 / AT-AR023 / AT-AR024



Note - There are no LEDs on these PICs.

AT-AR026



LED	State	Description
DUPLEX	Green	The port is operating at full-duplex.

Note - The four physical ports in this PIC are configured and behave as one ETH port from the viewpoint of the software running on the device.

AT-AR027



Note - There are no LEDs on this PIC.

Port Interface Cards

Network Service Modules

This section describes the Network Service Modules (NSMs) supported in Device Manager.

If one of these NSMs is installed in an NSM bay of a device, it will be displayed in the NSM bay image of the device panel in the main window. The operations available for the main device includes the ports in any of these NSMs.

AT-AR040



4-PIC slot NSM

Note - Up to four Port Interface Cards can be installed in the AT-AR040 NSM.

Note - There are no LEDs on this NSM.

AT-AR041 and AT-AR042



8-port BRI-S/T NSM

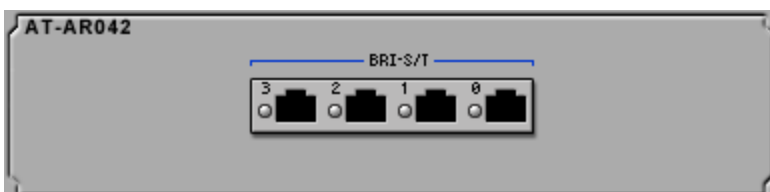

4-port BRI-S/T NSM

LED	State	Description
"DATA"	Orange	For permanent circuits, HDLC packets are being exchanged between the switch or router and another TE end system device (normally another switch or router) over the respective B-channel. For on-demand ISDN, there is a call up over the respective B-channel.
	Gray	No packet/data transmission over B-channel.

Network Service Modules

Uplink Modules

This section describes the Uplink Modules that can be installed on a switch. If one of these uplink modules is installed in an uplink bay of a switch, it will be displayed in the uplink bay image of the device panel in the main window. The operations available for the main device include the ports in any of these uplink modules.

AT-A35



Note - There are no LEDs on these modules.

AT-A39/T



LED	State	Description
DUPLEX	Green	The port is operating at full-duplex.
	Orange	The port is operating at half-duplex.

Note - Earlier versions of the AT-A39/T uplink module can only operate at 1000 Mbps.

AT-A4x

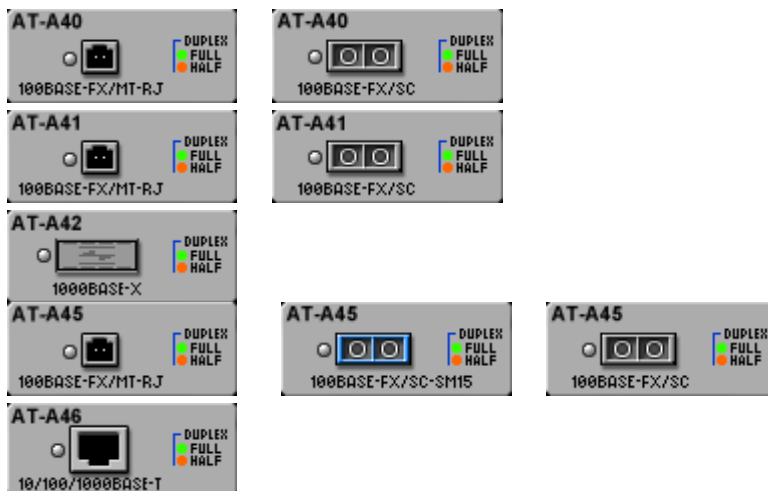

LED	State	Description
DUPLEX	Green	The port is operating at full-duplex.
	Orange	The port is operating at half-duplex.



AT-STACKM



Note - There are no LEDs on this module.

AT-A45/AT-A47/AT-STACKM



Note - There are no LEDs on this module.

Note - This image is only used on devices whose firmware does not allow Device Manager to differentiate the AT-A45, AT-A47 and AT-STACKM uplink modules from each other.

AT-A60/AT-A60i (AT-XEM-1XP)



Note - There are no LEDs on these modules.

AT-A61/AT-A61i (AT-XEM-12S)



Note - There are no LEDs on these modules.

AT-A62/AT-A62i (AT-XEM-12T)

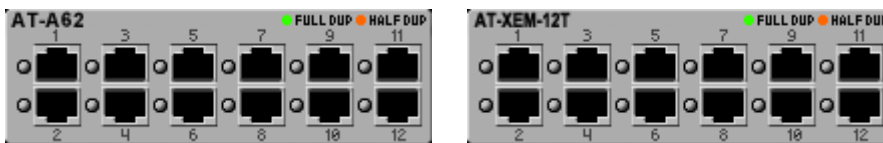

LED	State	Description
DUPLEX	Green	The port is operating at full-duplex.
	Orange	The port is operating at half-duplex.

AT-XEM-STK

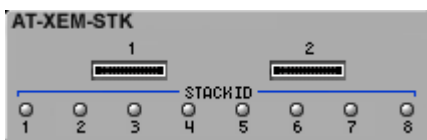

LED	State	Description
STACK	Green	The Stacked Unit is either the Stacking Master or Backup Master.
	Orange	The Stacked Unit is a slave switch.

AT-B1x



LED	State	Description
DUPLEX	Green	The port is operating at full-duplex.
	Orange	The port is operating at half-duplex.

AT-BSTACK1



Note - There are no LEDs on this module.

AT-XP9700



Note - There are no LEDs on this module.

© 1998-2009 Allied Telesis K. K.

All rights reserved. No part of this publication may be reproduced without prior written permission from Allied Telesis, K. K.

Microsoft is a registered trademark of Microsoft Corporation. Netscape Navigator is a registered trademark of Netscape Communications Corporation. All other product names, company names, logos or other designations mentioned herein are trademarks or registered trademarks of their respective owners.

Allied Telesis K. K. reserves the right to make changes in specifications and other information contained in this document without prior written notice. The information provided herein is subject to change without notice. In no event shall Allied Telesis K. K. be liable for any incidental, special, indirect, or consequential damages whatsoever, including but not limited to lost profits, arising out of or related to this manual or the information contained herein, even if Allied Telesis K. K. has been advised of, known, or should have known, the possibility of such damages.

613-000201 Rev M

USA Headquarters | 19800 North Creek Parkway | Suite 200 | Bothell | WA 98011 | USA | T: +1 800 424 4284 | F: +1 425 481 3895
European Headquarters | Via Motta 24 | 6830 Chiasso | Switzerland | T: +41 91 69769.00 | F: +41 91 69769.11
Asia-Pacific Headquarters | 11 Tai Seng Link | Singapore | 534182 | T: +65 6383 3832 | F: +65 6383 3830
www.alliedtelesis.com
