

# IS Series

Industrial Ethernet Layer 2 Switches

IS230-10GP

IS130-6GP



## Installation Guide

#### Acknowledgments

Intel and Pentium are trademarks of Intel Corporation.

Microsoft Windows and MS-DOS are registered trademarks of Microsoft Corp.

All other product names or trademarks are properties of their respective owners.

[www.alliedtelesis.com](http://www.alliedtelesis.com)

Please verify specifications before quoting. This guide is intended for reference purposes only.

All product specifications are subject to change without notice.

Copyright © 2023 Allied Telesis, Inc.

All rights reserved. No part of this publication may be reproduced without prior written permission from Allied Telesis, Inc.

Allied Telesis and the Allied Telesis logo are trademarks of Allied Telesis, Inc.. All other product names, company names, logos or other designations mentioned herein are trademarks or registered trademarks of their respective owners.

Allied Telesis, Inc. reserves the right to make changes in specifications and other information contained in this document without prior written notice. The information provided herein is subject to change without notice. In no event shall Allied Telesis, Inc. be liable for any incidental, special, indirect, or consequential damages whatsoever, including but not limited to lost profits, arising out of or related to this manual or the information contained herein, even if Allied Telesis, Inc. has been advised of, known, or should have known, the possibility of such damages.

# Electrical Safety and Emissions Standards

---

The IS230-10GP and IS130-6GP products meet the following standards:

## U.S. Federal Communications Commission

### Interference Statement

The IS230-10GP and IS130-6GP comply with part 15 of the FCC Rules. Operation is subject to the following two conditions:

(1) These devices may not cause harmful interference, and (2) these devices must accept any interference received, including interference that may cause undesired operation.

This equipment has been tested and found to comply with the limits for a Class A digital device, pursuant to part 15 of the FCC Rules. These limits are designed to provide reasonable protection against harmful interference in a controlled environment, such as a cabinet, hut or telecom closet. This equipment generates, uses and can radiate radio frequency energy and, if not installed and used in accordance with the instruction manual, may cause harmful interference to radio communications. However, there is no guarantee that interference will not occur in a particular installation. If this equipment does cause harmful interference to radio or television reception, which can be determined by turning the equipment off and on, the user is encouraged to try to correct the interference by one or more of the following measures:

- Reorient or relocate the receiving antenna.
- Increase the separation between the equipment and receiver.
- Connect the equipment into an outlet on a circuit different from that to which the receiver is connected.
- Consult the dealer or an experienced radio/TV technician for help.

The Federal Communications Commission warns that changes or modifications of the unit not expressly approved by the party responsible for compliance could void the user's authority to operate the equipment and any assurances of safety or performance, and could result in violation of part 15 of the FCC Rules.

## Industry Canada

This Class A digital apparatus complies with Canadian ICES-003.

*Cet appareil numérique de la classe A est conforme à la norme NMB-003 du Canada.*

This equipment complies with radio frequency exposure limits set forth by Industry Canada for a controlled environment.

*Cet équipement est conforme aux limites d'exposition aux radiofréquences définies par Industrie Canada pour un environnement contrôlé.*

## European Union Restriction of the Use of Certain Hazardous Substances (RoHS) in Electrical and Electronic Equipment

This Allied Telesis RoHS-compliant product conforms to the European Union Restriction of the Use of Certain Hazardous Substances (RoHS) in Electrical and Electronic Equipment. Allied Telesis ensures RoHS conformance by requiring supplier Declarations of Conformity, monitoring incoming materials, and maintaining manufacturing process controls.

## Certifications

---

The regulatory approvals of the product are listed in Table 1.

Table 1. Regulatory Approvals

Mechanical	EN 50022, EN 60715 Standardized mounting on rails
Compliance Mark	CE, FCC, RCM, TUV, VCCI
Safety	IS230-10GP and IS130-6GP switch: CAN/CSA C22.2 No.62368-1 EN/IEC/UL 62368-1 IS230-10GP switch only: CAN/CSA C22.2 No.60950-1 CAN/CSA C22.2 No.61010-2-201 EN/IEC/UL 60950-1 EN/IEC/UL 61010-2-201 IS130-6GP switch only: AS/NZS 62368.1
EMC	IS230-10GP and IS130-6GP switch: AS/NZS CISPR 32, class A EN55024; EN55032, class A EN61000-6-2; EN61000-6-4, class A FCC part 15B, class A ICES-003, issue 6, class A VCCI, class A IS130-6GP switch only: CAN/CSA-CISPR 22 CISPR 22; CISPR 32
Electrostatic Discharge (ESD) Radiated Susceptibility (RS) Electrical Fast Transient (EFT) Lighting/Surge immunity (Surge) Conducted immunity (CS) Magnetic field immunity	EN61000-4-2, level 3 EN61000-4-3, level 3 EN61000-4-4, level 3 EN61000-4-5, level 2 EN61000-4-6, level 3 EN61000-4-8, level 4
Railway	EN50121-4 (IS230-10GP switch only)
Traffic Control	NEMA-TS2 (IS230-10GP switch only)
Shock	EN60068-2-27 MIL-STD-810G 516.6
Freefall	IEC 60068-2-31
Vibration	IEC 60068-2-6 MIL-STD-810G 514.6

Table 1. Regulatory Approvals (Continued)

RoHS	Complies with Allied Telesis, Inc. document <i>Spec, Substance Compliance</i> No. 612-001876
------	--



**Warning**

In a domestic environment this product may cause radio interference in which case the user may be required to take adequate measures. ⚡ **E84**

---



**Warning**

Use an EN60825-1 certified optical fiber transceiver. ⚡ **L8**

---

## Translated Safety Statements

---

**Important:** Safety statements with the  symbol are translated into multiple languages in **Translated Safety Statements** at [alliedtelesisis.com/library/search](https://alliedtelesisis.com/library/search).

## Übersetzte Sicherheitshinweise

---

**Wichtig:** Sicherheitshinweise mit dem -Symbol werden in **Translated Safety Statements** bei [alliedtelesisis.com/library/search](https://alliedtelesisis.com/library/search) in mehrere Sprachen übersetzt.

## Declaraciones de seguridad traducidas

---

**Importante:** Las declaraciones de seguridad con el símbolo  se traducen a varios idiomas en **Translated Safety Statements** en [alliedtelesisis.com/library/search](https://alliedtelesisis.com/library/search).

## Consignes de sécurité traduites

---

**Important:** Les déclarations de sécurité avec le symbole  sont traduites en plusieurs langues en **Translated Safety Statements** sur [alliedtelesisis.com/library/search](https://alliedtelesisis.com/library/search).

## Dichiarazioni di sicurezza tradotte

---

**Importante:** Le dichiarazioni di sicurezza con il simbolo  sono tradotte in più lingue in **Translated Safety Statements** su [alliedtelesisis.com/library/search](https://alliedtelesisis.com/library/search).

## Översatta säkerhetsförklaringar

---

**Viktig:** Säkerhetsföreskrifter med -symbolen översätts till flera språk på **Translated Safety Statements** vid [alliedtelesisis.com/library/search](https://alliedtelesisis.com/library/search).

# Table of Contents

---

<b>Electrical Safety and Emissions Standards</b> .....	<b>3</b>
Certifications .....	4
<b>Preface</b> .....	<b>13</b>
Safety Symbols Used in this Document .....	14
Contact Allied Telesis .....	15
<b>Chapter 1: Overview</b> .....	<b>17</b>
Hardware Components .....	18
DIN Rail Bracket .....	21
Screw Holes for Wall Brackets .....	21
Features .....	22
IS Series Common Features .....	22
IS230-10GP Managed Features .....	23
Copper Ports .....	23
Power Over Ethernet .....	24
SFP Ports .....	24
Console Port .....	24
LEDs .....	25
Power/Alarm Connector .....	25
MAC Address Tables .....	25
IS230-10GP Management Software .....	25
IS230-10GP Management Methods .....	25
Installation Options .....	25
Additional Features .....	26
10/100/1000Base-T Copper Ports .....	27
Connector Type .....	27
Speed .....	27
Duplex Mode .....	27
Maximum Cable Distance .....	28
MDI/MDIX .....	28
Port Pinouts .....	28
Power over Ethernet .....	29
PoE Versions .....	29
Powered Device Classes for PoE and PoE+ .....	30
PoE Connection Guidelines .....	30
PoE Budget .....	31
Port Prioritization .....	32
SFP Ports .....	34
IS230-10GP Console Port .....	35
IS230-10GP Reset Button .....	36
Ground Screw .....	37
Power/Alarm Connector .....	38
Power Supply Inputs .....	38
P-Fail Alarm Relay Contacts .....	38
LEDs .....	40
Status LEDs .....	40
Copper Port LEDs .....	41
SFP Slot LEDs .....	42
PoE Status LEDs .....	43
Power Supplies .....	45

IS230-10GP .....	45
IS130-6GP .....	45
Power Supply Redundancy .....	46
Power Supply Connections .....	46
<b>Chapter 2: Begin Installation .....</b>	<b>47</b>
Review Safety Precautions .....	48
Ground Connection .....	49
Power/Alarm Connection .....	49
Safety Instructions .....	49
Safety Statements .....	51
Safety Precautions With Electricity .....	54
Review Site Requirements .....	55
Verify Package Contents .....	57
<b>Chapter 3: Install the Switch .....</b>	<b>61</b>
DIN Rail Installation .....	62
Install Switch On Concrete or Masonry Wall or Industrial Panel .....	64
<b>Chapter 4: Install Copper Port Cables .....</b>	<b>69</b>
Copper Port Cables .....	70
Install SFP Transceivers and Fiber Cables .....	71
<b>Chapter 5: Power On Switch .....</b>	<b>75</b>
Connect Ground Wire .....	76
Power/Alarm Connector Cables .....	81
Power/Alarm Connector Wiring .....	81
Apply Power To Switch .....	86
Verify Switch Operations .....	86
Start Management Session .....	87
Local Management Session .....	87
Network Management Session .....	88
<b>Chapter 6: Troubleshooting .....</b>	<b>91</b>
PWR 1 and PWR 2 LEDs .....	92
Copper Ports .....	93
SFP Ports .....	94
Power Over Ethernet .....	95
<b>Appendix A: Technical Specifications .....</b>	<b>97</b>
Physical Specifications .....	98
Dimensions .....	98
Weights .....	99
Cabinet Dimensions .....	99
Environmental Specifications .....	100
Power Specifications .....	101
Copper Cable Requirements .....	102
RJ-45 Copper Ethernet Port Pinouts .....	103
RJ-45 Style Serial Console Port Pinouts .....	105
Power/Alarm Connectors .....	106
Pin Assignments .....	106
P-Fail Alarm Contact Rating .....	106

# Figures

---

Figure 1: IS230-10GP Switch Front Panel.....	18
Figure 2: IS130-6GP Switch Front Panel.....	18
Figure 3: IS230-10GP Switch Top Panel.....	19
Figure 4: IS130-6GP Switch Top Panel.....	19
Figure 5: IS230-10GP Switch Back Panel Features.....	20
Figure 6: IS130-6GP Switch Back Panel Features.....	21
Figure 7: IS Series Power/Alarm Connectors.....	38
Figure 8: Example of the P-Fail Alarm Relay Circuit.....	39
Figure 9: IS230-10GP Copper Port LEDs: Ports 1-10.....	41
Figure 10: IS130-6GP Copper Port LEDs: Ports 1-5.....	41
Figure 11: IS230-10GP SFP LEDs: Ports 9 and 10.....	42
Figure 12: IS130-6GP SFP LED: Port 6.....	42
Figure 13: IS230-10GP PoE Status LEDs: Ports 1-8.....	43
Figure 14: IS130-6GP PoE Status LEDs: Ports 1-4.....	43
Figure 15: Pre-installed Components on the IS230-10GP Front Panel.....	57
Figure 16: Pre-installed Components on the IS130-6GP Front Panel.....	58
Figure 17: Pre-installed Components on the Top Panel.....	59
Figure 18: Pre-installed DIN Rail Bracket on the Back Panel.....	59
Figure 19: IS230-10GP Accessory Kit Components.....	60
Figure 20: IS130-6GP Accessory Kit Components.....	60
Figure 21: Orientation of the Switch on a DIN Rail.....	62
Figure 22: Install Top Slot of DIN Rail Bracket onto DIN Rail.....	63
Figure 23: Install Switch on DIN Rail.....	63
Figure 24: Remove Din Rail Mounting Bracket.....	65
Figure 25: Install Wall Mount Brackets on the Back of the Switch.....	65
Figure 26: Mark Wall Bracket Hole Locations.....	66
Figure 27: Install Switch Using Wall Brackets.....	67
Figure 28: Remove the Dust Plug from an SFP Slot.....	71
Figure 29: Install SFP Transceiver.....	72
Figure 30: Remove Dust Cover from SFP Transceiver.....	72
Figure 31: Connect Fiber Optic Cable To SFP Transceiver.....	73
Figure 32: Stripping the Grounding Wire.....	77
Figure 33: Sliding a Heat-shrink Tube Over the Grounding Wire.....	77
Figure 34: Sliding the Ring Terminal Lug on the Grounding Wire.....	78
Figure 35: Crimping the Ring Terminal Lug.....	78
Figure 36: Sliding the Heat-Shrink Tube Over the Ring Terminal Lug.....	78
Figure 37: Heating the Heat-Shrink Tube.....	78
Figure 38: Removing the Grounding Screw.....	79
Figure 39: Attaching the Grounding Wire to the Switch.....	79
Figure 40: Strip Power or Alarm Wire.....	81
Figure 41: Wrap Wire Strands.....	82
Figure 42: Remove Power/Alarm Connector.....	82
Figure 43: Loosen Power/Alarm Connector Wire Retaining Screws.....	83
Figure 44: Insert Power Supply and Alarm Wires into Power/Alarm Connector.....	83
Figure 45: Verify Wire Installation.....	84
Figure 46: Tighten Wires In Power/Alarm Connector.....	84
Figure 47: Insert the Power/Alarm Connector.....	85
Figure 48: Fasten the Power/Alarm Connector to Chassis.....	85
Figure 49: IS230-10GP Switch Dimensions.....	98
Figure 50: IS130-6GP Switch Dimensions.....	99

Figures

Figure 51: RJ-45 Port Pin Layout (Front View) ..... 103  
Figure 52: IS Series Power/Alarm Connectors ..... 106

# Tables

---

Table 1: Regulatory Approvals .....	4
Table 2: Maximum Power Levels .....	29
Table 3: PoE and PoE+ Powered Device Classes .....	30
Table 4: Maximum Installation Site Temperatures Versus SFP Temperature Ratings .....	34
Table 5: Status LEDs .....	40
Table 6: Copper Port LEDs .....	41
Table 7: SFP Slot LED .....	43
Table 8: PoE Status LED Descriptions .....	44
Table 9: Ground Resistivity Recommendations .....	56
Table 10: Product Dimensions .....	98
Table 11: Product Weights .....	99
Table 12: Minimum Cabinet Dimensions .....	99
Table 13: Environmental Specifications .....	100
Table 14: Maximum Power Consumption .....	101
Table 15: External Power Supply DC Output Specifications .....	101
Table 16: Heat Dissipation (British Thermal Units/Hour) .....	101
Table 17: Pin Signals for 10 and 100 Mbps .....	103
Table 18: Pin Signals for 1000 Mbps .....	104
Table 19: Console Port Pin Signals .....	105
Table 20: Power Connector Pinout Assignments .....	106



# Preface

---

This guide contains the hardware installation instructions for the IS230-10GP and IS130-6GP switches. The preface contains the following sections:

- “Safety Symbols Used in this Document” on page 14
- “Contact Allied Telesis” on page 15

## Safety Symbols Used in this Document

---

This document uses the following conventions.

---

**Note**

Notes provide additional information.

---



---

**Caution**

Cautions inform you that performing or omitting a specific action may result in equipment damage or loss of data.

---



---

**Warning**

Warnings inform you that performing or omitting a specific action may result in bodily injury.

---



---

**Warning**

Laser warnings inform you that an eye or skin hazard exists due to the presence of a Class 1 laser device.

---



---

**Warning**

Warnings inform you of hot surfaces.

---

## Contact Allied Telesis

---

If you need assistance with this product, you may contact Allied Telesis technical support by going to the Support & Services section of the Allied Telesis web site at **[www.alliedtelesis.com/support](http://www.alliedtelesis.com/support)**. You can find links for the following services on this page:

- ❑ 24/7 Online Support - Enter our interactive support center to search for answers to your questions in our knowledge database, check support tickets, learn about Return Merchandise Authorizations (RMAs), and contact Allied Telesis technical experts.
- ❑ USA and EMEA phone support - Select the phone number that best fits your location and customer type.
- ❑ Hardware warranty information - Learn about Allied Telesis warranties and register your product online.
- ❑ Replacement Services - Submit an RMA request via our interactive support center.
- ❑ Documentation - View the most recent installation guides, user guides, software release notes, white papers and data sheets for your product.
- ❑ Software Updates - Download the latest software releases for your product.

For sales or corporate contact information, select your region and country and then go to **[www.alliedtelesis.com/contact](http://www.alliedtelesis.com/contact)**.



## Chapter 1

# Overview

---

This chapter describes the hardware features for the IS230-10GP and IS130-6GP switches. This chapter's sections are listed here:

- ❑ "Hardware Components" on page 18
- ❑ "Features" on page 22
- ❑ "10/100/1000Base-T Copper Ports" on page 27
- ❑ "Power over Ethernet" on page 29
- ❑ "SFP Ports" on page 34
- ❑ "IS230-10GP Console Port" on page 35
- ❑ "IS230-10GP Reset Button" on page 36
- ❑ "Ground Screw" on page 37
- ❑ "Power/Alarm Connector" on page 38
- ❑ "LEDs" on page 40
- ❑ "Power Supplies" on page 45

# Hardware Components

The front panel of the IS230-10GP switch is shown in Figure 1.

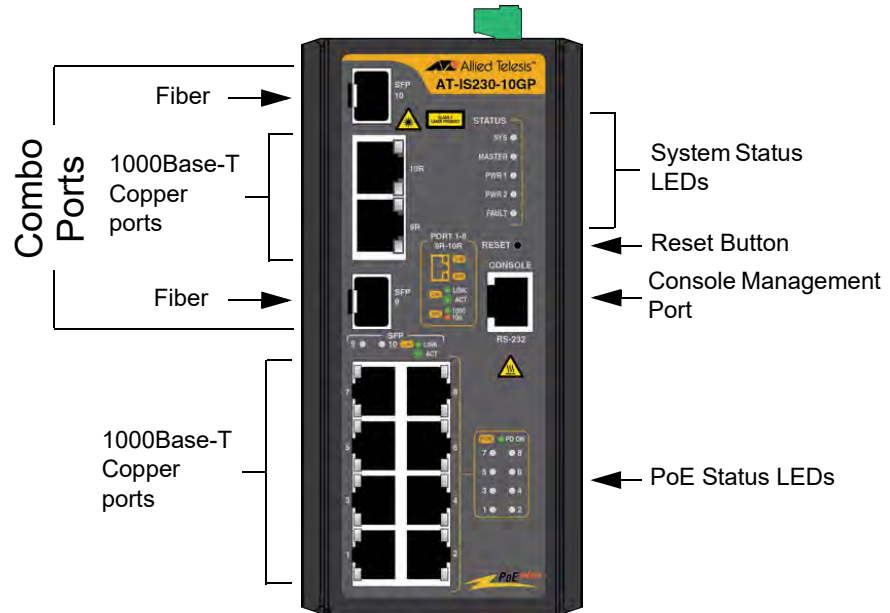

Figure 1. IS230-10GP Switch Front Panel

The front panel of the IS130-6GP switch is shown in Figure 2.

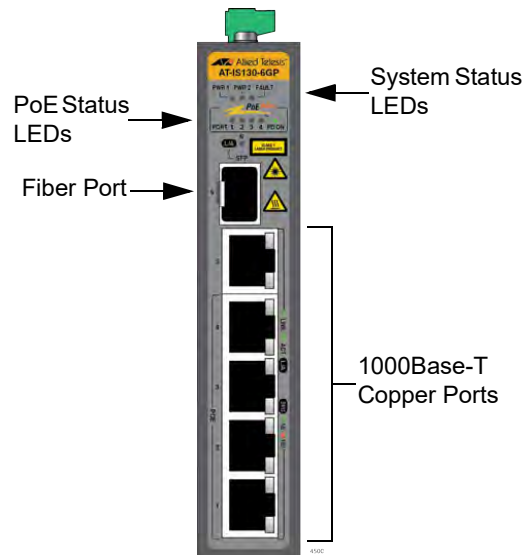

Figure 2. IS130-6GP Switch Front Panel

Figure 3 shows the components on the IS230-10GP switch top panel.

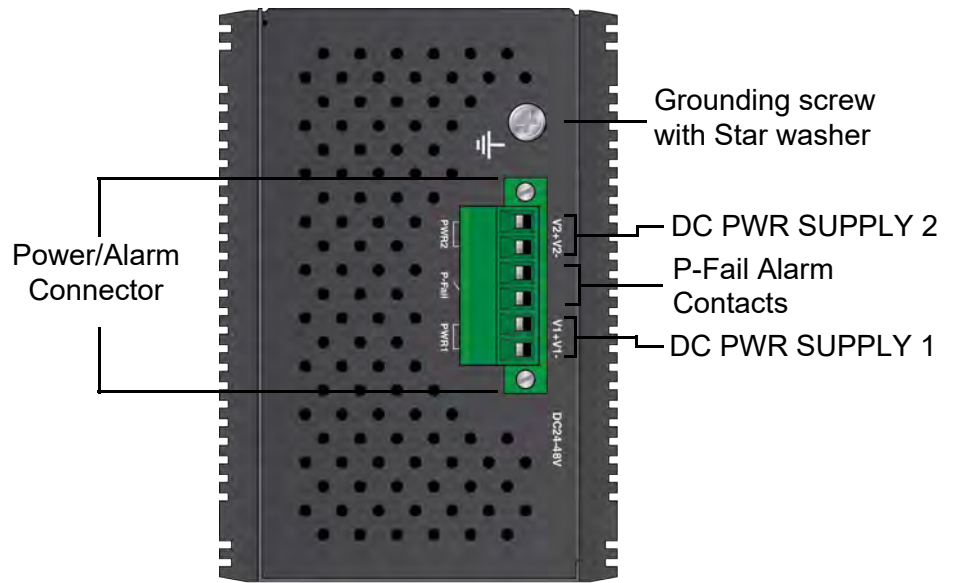

Figure 3. IS230-10GP Switch Top Panel

Figure 4 shows the components on the IS130-6GP switch top panel.

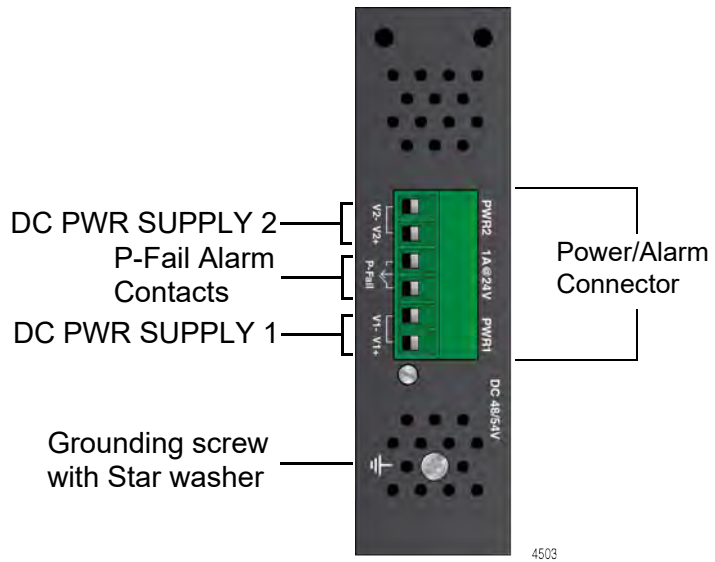

Figure 4. IS130-6GP Switch Top Panel

Figure 5 identifies the components on the IS230-10GP switch back panel.

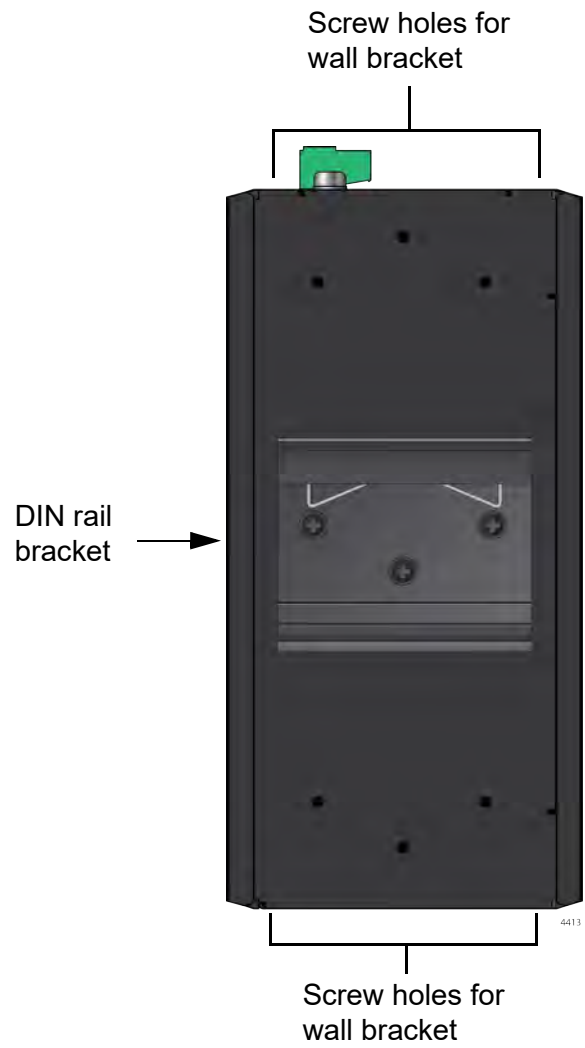

Figure 5. IS230-10GP Switch Back Panel Features

Figure 6 identifies the components on the IS230-10GP switch back panel.

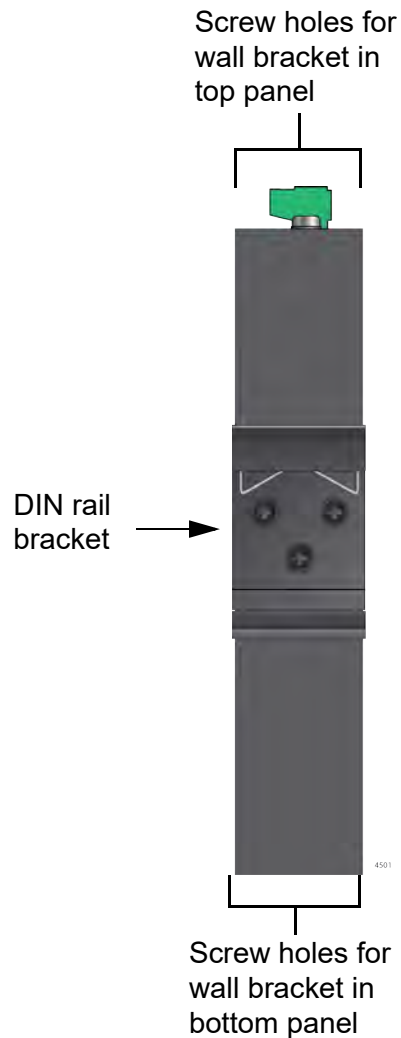

Figure 6. IS130-6GP Switch Back Panel Features

**DIN Rail Bracket**

Each switch comes with one DIN rail bracket pre-installed on the back panel. The bracket is compatible with DIN 35x7.5mm rails.

**Screw Holes for Wall Brackets**

The IS230-10GP back panel has six holes in the back panel for securing the two wall brackets. These brackets are included in the accessory kit.

The IS130-6GP top and bottom panels have four holes each for securing the two wall brackets. These brackets and the mounting screws are included in the accessory kit.

## Features

---

The basic features of the IS Series switches can be found in these sections:

- ❑ "IS230-10GP Managed Features"
- ❑ "Copper Ports" on page 23
- ❑ "Power Over Ethernet" on page 24
- ❑ "SFP Ports" on page 24
- ❑ "Console Port" on page 24
- ❑ "LEDs" on page 25
- ❑ "Power/Alarm Connector" on page 25
- ❑ "MAC Address Tables" on page 25
- ❑ "IS230-10GP Management Software" on page 25
- ❑ "IS230-10GP Management Methods" on page 25
- ❑ "Installation Options" on page 25
- ❑ "Additional Features" on page 26

### **IS Series Common Features**

The following hardware standard features are supported on both the IS230-10GP and IS130-6GP switches:

- ❑ IEEE 802.3 10-BASE-T, Ethernet
- ❑ IEEE 802.3u 100-BASE-TX, Fast Ethernet
- ❑ IEEE 802.3ab 1000BASE-T, Gigabit Ethernet
- ❑ IEEE 802.3z 1000BASE-X, Gigabit Ethernet
- ❑ IEEE 802.3x Flow Control
- ❑ IEEE 802.3at PoE
- ❑ IEEE 802.3af PoE+

## **IS230-10GP Managed Features**

The following managed features are only supported on the IS230-10GP switch:

- Supports Port Mirroring
- IEEE 802.1p LANs (VLANs)
- IEEE 802.1s Multiple Spanning Tree Protocol (MSTP)
- IEEE 802.1x (Port-Based, MD5/TLS/TTLS/PEAP Encryption)
- IEEE 802.3ad Link Aggregation Control Protocol (LACP)
- IEEE 802.3az Energy-Efficient Ethernet
  - LPI at 100BASE-TX support
  - LPI at 1000BASE-T support
- IEEE 802.1p Quality of Service (QoS)
- IEEE 802.1x (Port-Based, MD5/TLS/TTLS/PEAP Encryption)
- IEEE 802.1Q Virtual LANs (VLANs)
- IEEE 802.1d Standard Spanning Tree Protocol
- IEEE 802.1w Rapid Spanning Tree Protocol (RSTP)
- X-Ring Pro (ultra high-speed recovery time < 20 ms)
- RADIUS Management
- ARP Spoofing
- Access Control List
- IP Source Guard
- DHCP Snooping

## **Copper Ports**

Here is a summary of the basic features of the IS Series 10/100/1000 Mbps Copper ports:

- 100 meters (328 feet) maximum operating distance.
- Auto-MDI/MDIX feature.
- Jumbo frames from 1518 to 9216 bytes.
- 10/100/1000Base-T/TX RJ-45 Copper ports with IEEE 802.3 af/at PoE.
  - IS230-10GP switch - 8 ports with PoE.
  - IS130-6GP switch - 5 ports total: 4 ports with PoE and 1 port without PoE.
- Two combo ports 100/1000Base-T/TX RJ-45/SFP for the IS230-10GP switch only.

## Power Over Ethernet

The IEEE 802.3 af/at Power over Ethernet feature is offered on both the IS230-10GP and IS130-6GP switches.

### IS230-10GP Switch

Ports 1 to 8 offer the following PoE characteristics:

- Maximum PoE budget for the switch is 120 watts
- Maximum port PoE budget is 30 watts
- Powered device classes 0 to 4 port are supported
- Alternative A wiring is available for PoE or PoE+ devices

### IS130-6GP Switch

Ports 1 to 4 offer the following PoE characteristics:

- Total PoE budget for the switch is 60W at 48V
- Maximum current per port is 0.32A at 48V
- Total PoE budget for the switch is 90W at 54V
- Maximum current per port is 0.58A at 54V
- Powered device classes 0 to 4 port are supported
- Alternative A wiring is available for PoE or PoE+ devices

---

**Note**

Port 5 of the IS130-6GP switch does not support the PoE feature.

---

## SFP Ports

The two SFP combo ports on the IS230-10GP and the one SFP slot on the IS130-6GP support 100M and 1000M optical transceivers.

---

**Note**

SFP transceivers must be purchased separately from the switch. Refer to the product data sheet for a list of supported transceivers.

---

## Console Port

The IS230-10GP has one RJ-45 connector dedicated as an out-of-band, Console serial management port.

---

**Note**

The IS130-6GP is an unmanaged switch with no console port.

---

**LEDs** The following LEDs are on the front panel of the IS Series switches:

- Link/activity and duplex mode LEDs for the Copper ports.
- Link/activity LED for each SFP port.
- Power supply status LED for each power supply input.
- Fault (Alarm) LED.
- PoE Active status LEDs for each PoE Copper port.
- System Status LED (IS230-10GP only).
- Ring Master Active status LED (IS230-10GP only).

**Power/Alarm Connector**

The switch has one connector on top of the switch which includes pins for the following functions:

- Two DC power supply connections
- P-Fail (Power Fail) alarm relay contacts for an external alert device, such as a buzzer or LED, to indicate the failure of one of the power supplies

**MAC Address Tables**

Here are the basic features of the MAC address tables:

**IS230-10GP Switch**

- Storage capacity up to 8,192 MAC address entries
- Automatic learning and aging of 300 second default aging time - range from 10 to 630 seconds

**IS130-6GP Switch**

- Storage capacity up to 2,048 MAC address entries
- Automatic learning and aging of 300 second

**IS230-10GP Management Software**

The switches support the following management software interfaces:

- Command line interface
- Web browser interface

**IS230-10GP Management Methods**

You can manage the switches in the following ways:

- Local management through the Console port
- Remote Telnet or secure shell management
- Remote HTTP or HTTPS web browser management
- SNMPv1, v2c, or v3, Standard MIB, Private MIB

**Installation Options**

The IS Series switches support the following installation options:

- DIN rail installation (compatible with DIN 35x7.5mm rail)
- Concrete or masonry wall or industrial panel

## **Additional Features**

Here are additional features for the IS Series switches:

- ❑ Reset button (IS230-10GP only)
- ❑ Two DC power supply input connections
- ❑ Extended environmental range (Refer to “Environmental Specifications” on page 100 for more information)

## 10/100/1000Base-T Copper Ports

---

This section describes the following hardware aspects of the Copper ports on the IS Series switches:

- ❑ “Connector Type”
- ❑ “Speed”
- ❑ “Duplex Mode”
- ❑ “Maximum Cable Distance”
- ❑ “MDI/MDIX” on page 28
- ❑ “Port Pinouts” on page 28

### Connector Type

The Copper ports consist of RJ-45 connectors. The ports use four pins at 10 or 100 Mbps and all eight pins at 1000 Mbps. The pin assignments are listed in Table 16 on page 103 and Table 17 on page 104.

### Speed

The ports can operate at 10, 100, or 1000 Mbps. The switch can set the speeds automatically with Auto-Negotiation.

---

#### Note

In the case of the IS230-10GP switch, you can manually set the speeds with the management software. The Copper ports must be set to Auto-Negotiation to operate at 1000 Mbps. In the case of the IS130-6GP switch, you cannot set the Copper ports manually to 1000 Mbps.

---

### Duplex Mode

The Copper ports on the IS Series switches can operate in either half- or full-duplex mode at 10 or 100 Mbps. Ports operating at 1000 Mbps can only operate in full-duplex mode. The Copper ports are IEEE 802.3u Auto-Negotiation compliant. The switch can set the duplex modes automatically.

---

#### Note

With the IS230-10GP switch, switch ports connected to 10 or 100 Mbps end nodes that do not support Auto-Negotiation should not use Auto-Negotiation to set their speed and duplex mode settings, because duplex mode mismatches might occur. You should disable Auto-Negotiation and set the speed and duplex mode settings manually with the AlliedWare Plus operating system.

---

---

**Note**

With the IS230-10GP switch, you can disable Auto-Negotiation and set the duplex modes manually via the switch management. Speed and duplex mode settings can be set independently of each other on the ports. For example, the speed of a port can be configured manually while its duplex mode is established through Auto-Negotiation.

---

**Maximum Cable Distance**

The ports have a maximum operating distance of 100 meters (328 feet).

**MDI/MDIX**

The 10/100/1000 Mbps Copper ports on the IS Series switches are IEEE 802.3ab compliant, with automatic MDI/MDIX detection. This feature automatically configures the ports to MDI or MDI-X depending on the wiring configurations of the end nodes.

**Port Pinouts**

Refer to Table 16 on page 103 for the pinouts of the Copper ports at 10 or 100 Mbps and to Table 17 on page 104 for the port pinouts at 1000 Mbps.

## Power over Ethernet

The ports that support PoE can supply electrical power to network devices over the same Copper cables that carry network traffic. The feature can simplify network installation and maintenance because it allows you to use the switch as a central power source for other network devices.

Devices that receive their power over Ethernet cables are called powered devices (PD). Examples of PDs include wireless access points, IP telephones, web cams, and even other Ethernet switches. A PD connected to a port on the IS Series switches receives both network traffic and power over the same Copper cable.

### PoE Versions

The IS Series switches support the following versions of Power over Ethernet:

- ❑ PoE (IEEE 802.3af)
- ❑ PoE+ (IEEE 802.3at)
- ❑ For PoE and PoE+ devices, power is delivered from the switch over four of the eight Ethernet cable strands using the Alternative A method. With Alternative A, power is delivered on strands 1, 2, 3, and 6, which are the same strands that carry the 10/100Base-TX network traffic.

Table 1 lists the switch ports that support PoE and the maximum power levels. The total available PoE power that the IS230-10GP switch can supply from all the ports combined is 120 Watts. The total available PoE power that the IS130-6GP switch can supply from all the ports combined is 90 Watts.

Table 1. Maximum Power Levels

Switch Model/ Ports	Switch Maximum Power Budget	PoE Version	Maximum Power Output at Switch Port	Maximum Power at PD
IS230-10GP (Ports 1 to 8)	120 Watts	PoE	15.4W	13W
		PoE+	30.0W	25.5W
IS130-6GP (Ports 1 to 4)	90 Watts DC51~57V input (IEEE802.3at) 90W DC45~57V input (IEEE802.3af) 61.6W	PoE	15.4W	13W
		PoE+	30.0W	25.5W

## Powered Device Classes for PoE and PoE+

The PoE and PoE+ standards define five powered device classes. The classes are defined by the power requirements of the powered devices. The classes are shown in Table 2. The IS Series switches support all five classes.

Table 2. PoE and PoE+ Powered Device Classes

Class	Usage	Maximum Power Output at the Switch Port	PD Power Range
0	Default	15.4W	0.44W to 13W
1	Optional	4.0W	0.44W to 3.84W
2	Optional	7.0W	3.84W to 6.49W
3	Optional	15.4W	6.94W to 13W
4	Optional	30.0W	13W to 25.5W

## PoE Connection Guidelines

Here are guidelines for connecting different types of powered devices to the PoE switch ports:

- ❑ PoE and PoE+ devices that comply with the IEEE 802.3af and 802.3at standards and that support Alternative A and can be connected to any of the PoE Copper ports.
- ❑ PoE and PoE+ devices that do not comply with the standards and only support Alternative A can also be connected to any available PoE Copper port.

---

### Note

Alternative B method of delivering PoE power (over strands 4, 5, 7 and 8) is not supported.

---

- ❑ Non-PoE devices can be connected to any of the Copper ports on the switch. Ports connected to network nodes that are not powered devices (that is, devices that receive power from another power source) function as regular Ethernet ports, without delivering power to the device. The PoE feature remains enabled on the ports but no power is delivered to the devices.

## PoE Budget

Both IS Series switches have an overall PoE budget. This is the total wattage the switch has available for all the powered devices connected to its PoE ports. The maximum PoE power available at any one time is:

- IS230-10GP switch - 120W
- IS130-6GP switch:
  - 51~57VDC input (IEEE802.3at) 90W
  - 45~57VDC input (IEEE802.3af) 61.6W

The PoE budget can never be more than these values on the respective switches, but it can be less, depending on the maximum power rating of the DC power supply.

The number of powered devices the switch can support at one time depends on the switch's PoE budget and the wattage requirements of the powered devices. As long as the total wattage requirements of all the powered devices is less than the budget of the switch, the switch can supply power to all the devices.

If the total wattage requirements exceed the PoE budget on the IS130-6GP switch, power will be delivered to the ports based on the sequence of being plugged in. In the case of the IS230-10GP switch, power is delivered to specific ports using a mechanism referred to as port prioritization, refer to "Port Prioritization" on page 32.

To determine whether the wattage requirements of the PoE devices you plan to connect to the switch exceed its budget, refer to their documentation for their power requirements and add the requirements together. The switch will be able to power all the devices simultaneously as long as the total is below its PoE budget. If the total exceeds the available power budget, you should consider reducing the number of PoE devices so that all the devices receive power.

The switch can handle different power requirements on different ports. This enables you to connect different classes of PoE equipment to the PoE ports of the switch. (See Table 2 on page 30 for the PoE class power ranges.)

## **Port Prioritization**

If the power requirements of the powered devices exceed the switch's power budget, the switch denies power to some ports based on a system called port prioritization. You may use this mechanism to ensure that powered devices critical to the operations of your network are given preferential treatment by the switch in the distribution of power should the demands of the devices exceed the available PoE power capacity.

### **IS130-6GP Switch**

The IS130-6GP switch has two mechanisms for setting port priorities for powered devices. The selected mechanism depends on when you connect powered devices to the ports. If you connect powered devices to the ports and then power ON the switch, PoE power is provided to the lowest port first and then to the ports in ascending order as long as the overall switch budget is not exceeded. If the PoE power budget is exceeded, no power is provided to the higher ports.

If you connect powered devices to the ports when the switch is already powered on, then power is supplied to the ports in the order that they are connected.

### **IS230-10GP Switch**

You can configure the port priority feature using the management software. There are three priority levels: Critical, High, and Low.

Ports set to the Critical level, the highest priority level, are guaranteed power before any of the ports assigned to the other two priority levels. Ports assigned to the other priority levels receive power only if all the Critical ports are receiving power. Ports that are connected to your most critical powered devices should be assigned to this level. If there is not enough power to support all the ports set to the Critical priority level, power is provided to the ports in ascending order starting with the lowest port number.

The High level is the second highest level. Ports set to this level receive power only if all the ports set to the Critical level are already receiving power. If there is not enough power to support all of the ports set to the High priority level, power is provided to the ports in ascending order starting with the lowest port number.

The lowest priority level is Low. This is the default setting. Ports set to this level only receive power if all of the ports assigned to the other two levels are already receiving power. As with the other levels, if there is not enough power to support all of the ports set to the Low priority level, power is provided to the ports in ascending order starting with the lowest port number.

Power allocation is dynamic. Ports supplying power to powered devices may cease power transmission if the switch's power budget is at maximum usage and new powered devices, connected to ports with higher priorities, become active.

## SFP Ports

---

Each SFP slot supports Ethernet 100/1000Base fiber optic, MSA-compliant SFP transceivers. You can use the transceivers to connect the switch to other network devices over large distances, build a high-speed backbone network between network devices, or connect high-speed devices, such as servers, to your network.

---

**Note**

SFP transceivers must be purchased separately from the switch. Refer to the product data sheet for a list of supported transceivers.

---

To protect SFP transceivers from heat-related damage, you should select transceivers whose maximum operating temperatures exceed the anticipated maximum ambient temperature at the switch installation site. Table 3 provides recommendations for SFP maximum operating temperatures for several ambient site temperatures.

Table 3. Maximum Installation Site Temperatures Versus SFP Temperature Ratings

Maximum Ambient Installation Site Temperature	Recommended Maximum SFP Operating Temperature
75° C (167° F)	105° C (221° F)
65° C (149° F)	95° C (203° F)
55° C (131° F)	85° C (185° F)

## IS230-10GP Console Port

---

The Console port is a serial RS-232 port offered on the IS230-10GP switch only. You can access the management software to configure the features via the Console port. Management sessions conducted through the Console port are called local management sessions because you have to be at the location of the switch. Local management sessions do not interfere with the network operations of the switch and are not performed over the network. Consequently, the switch does not need an IP address for this type of management.

Local management sessions require the following items:

- Terminal or a personal computer with a terminal emulation program
- Management cable (provided in the shipping box)

To establish a local management session with the switch, connect a Terminal or a personal computer with a terminal emulation program to the Console port, which has an RJ-45 style (8P8C) connector, with a management cable.

The Console port has the following settings:

- Default baud rate: 115200 bps (Range is 9600 to 115200 bps)
- Data bits: 8
- Parity: None
- Stop bits: 1
- Flow control: None

---

**Note**

These settings are for a DEC VT100 or ANSI terminal, or an equivalent terminal emulation program.

---

## IS230-10GP Reset Button

---

The IS230-10GP has a Reset button. The reset button is recessed in the chassis. To press it, use a straightened paper clip or similar object.

The Reset button has these functions:

- ❑ Hold it for 5 sec: The switch reboots. After initializing its management software, the switch returns all its configuration settings to their default values.
- ❑ Hold it for 2 sec: The switch reboots. After initializing its management software, the switch loads its last saved configuration.



### **Caution**

The switch does not forward network traffic for approximately one minute while it initializes its management operating system. Some network traffic may be lost.

---

## Ground Screw

---

The ground screw is used to connect the chassis to the earth ground at the installation site. The instructions for connecting the post are provided in “Connect Ground Wire” on page 76.

**Warning**

The switch must be connected to an earth ground. Do not operate the device without an earth ground.

---

## Power/Alarm Connector

The power/alarm connector on the top panel of the switch provides pins for one primary DC power supply, one redundant DC power supply, and one alarm relay. Refer to Figure 7.

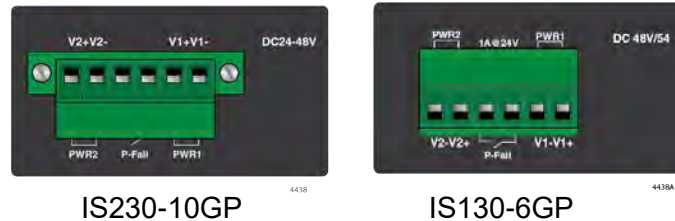

Figure 7. IS Series Power/Alarm Connectors

### Power Supply Inputs

The PWR 1 and PWR 2 connector is for the DC power supplies. You can power the unit with one power supply or two power supplies for power redundancy, which protects the device from power loss in the event that one of the DC power units fails or loses power.

The switches support the following types of power sources:

- AC/DC rectifiers
- Un-interruptible power supplies

The power supply requirements for both the IS230-10GP and IS130-6GP models are described in “Power Supplies” on page 45. Allied Telesis does not sell or provide power supplies for these products.

### P-Fail Alarm Relay Contacts

You can specify the type of Alarm policy that will activate the P-Fail alarm relay contacts when the fault is detected. The IS130-6GP switch alarm indicates a power supply failure. Within the IS230-10GP switch management software, the alarm type is configurable and detected. Examples of alarm conditions in the IS230-10GP are power supply failures, fiber alarms, and port alarms.

The power/alarm connector on the top panel of the switch includes two pins for the P-Fail alarm relay contacts. You may connect these contact connections to an external alert device. The switch can use the device to alert you to alarm conditions, such as power supply failures or ports without links. Here are two examples of alert devices:

- LEDs
- Buzzers

The switch does not supply power on the P-Fail alarm relay contacts, which only provide an ON/OFF signal via a dry contact relay. When an alarm occurs, the switch changes the circuit from open (off) to closed (on).

The circuit remains closed until the alarm is resolved, at which point the switch automatically opens it again. The processes to resolving alarms can vary.

Power from an external power source is required for an external alert device which is activated when the P-Fail alarm relay contacts are closed. Here are the contact rating specifications for the P-Fail alarm relay:

- ❑ 24VDC maximum
- ❑ 1.0A maximum



---

### Caution

The power supplied to the P-Fail alarm relay contacts must not exceed the above specifications or the contacts can potentially be damaged.

---

An example of the feature is illustrated in Figure 8. The P-Fail alarm relay contacts are attached to a LED alert device. The alert device is configured so the LED is off when the circuit is open and on when the circuit is closed.

Now assume you want the switch to close the circuit and activate the LED on the alert device whenever any port on the switch does not have a link to a network device. If the switch detects that a port does not have a link, it changes the circuit from open to closed. The alert device, detecting the change to the circuit, turns the LED on. When the switch detects that all its ports have links again, it opens the circuit, which turns off the LED.

---

### Note

External alarm devices are not available from Allied Telesis.

---

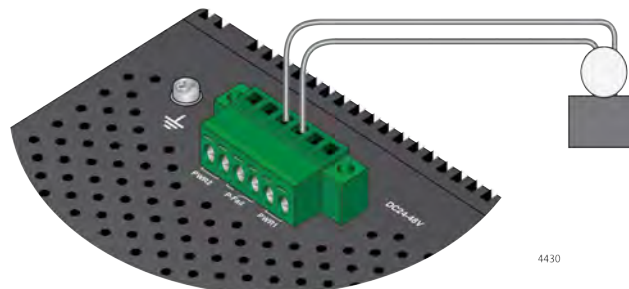

LED  
 Circuit open - LED off  
 Circuit closed - LED on

Figure 8. Example of the P-Fail Alarm Relay Circuit

## LEDs

---

The following sections describe the LEDs on the switches:

- “Status LEDs” on page 40
- “Copper Port LEDs” on page 41
- “SFP Slot LEDs” on page 42
- “PoE Status LEDs” on page 43

**Status LEDs** The status LEDs are defined in Table 4.

Table 4. Status LEDs

IS230-10GP	IS130-6GP	LED	State	Description
X		SYS	Solid Green	System is operating normally
			Off	System is powered down, there is a system crash or an operation is initiating.
X		MASTER	Solid Green	Active when switch is the Ring Master of an X-Ring configuration
			Off	Switch is not the Ring Master of an X-Ring configuration
X	X	PWR 1	Solid Green	The switch is receiving power on the PWR 1 connector contacts and is operating normally.
			Off	The PWR 1 supply is powered down or is not installed.
X	X	PWR 2	Solid Green	The switch is receiving power on the PWR 2 connector contacts and is operating normally.
			Off	The PWR 2 supply is powered down or is not installed.
X	X	FAULT	Solid Red	Defined major Alarm policy is triggered. See “P-Fail Alarm Relay Contacts” on page 38 for more information.
			Off	System is operating normally or is powered OFF.

## Copper Port LEDs

Copper ports have two LEDs.

The IS230-10GP Copper port LEDs are identified in Figure 9.

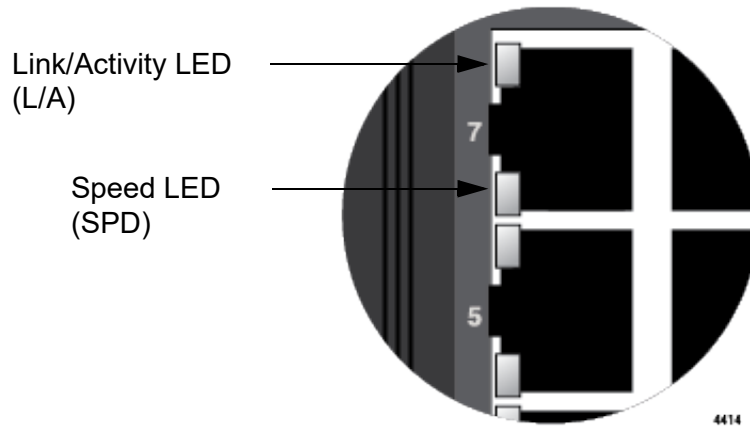

Figure 9. IS230-10GP Copper Port LEDs: Ports 1-10

The IS130-6GP Copper port LEDs are identified in Figure 10.

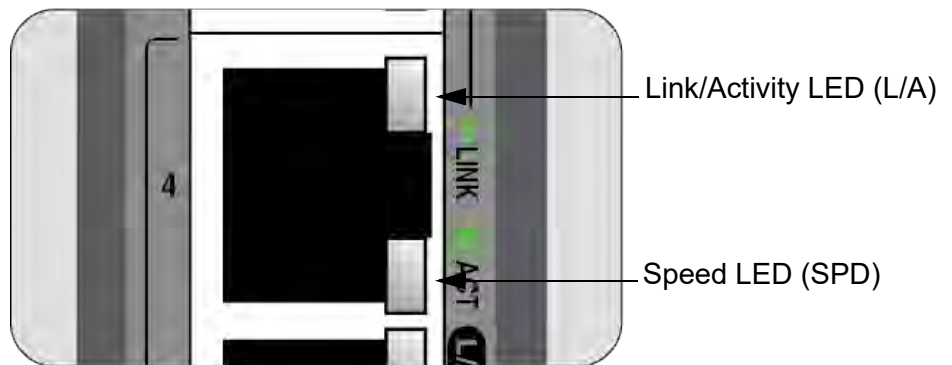

Figure 10. IS130-6GP Copper Port LEDs: Ports 1-5

The descriptions of the Copper port LEDs are provided in Table 5.

Table 5. Copper Port LEDs

LED	State	Description
LINK/ACT (L/A)	Solid Green	The port has established a link to a network device.
	Flashing Green	The port is transmitting or receiving data.
	Off	The port has not established a link with a network device.

Table 5. Copper Port LEDs

LED	State	Description
SPEED (SPD)	Solid Green	The port is operating at 1000 Mbps.
	Solid Amber	The port is operating at 100 Mbps.
	Off	The port has not established a link with a network device or the port is operating at 10 Mbps.

**SFP Slot LEDs** Each SFP slot has one LED.

The IS230-10GP SFP LEDs for Combo ports 9 and 10 are shown in Figure 11.



Figure 11. IS230-10GP SFP LEDs: Ports 9 and 10

The IS130-6GP SFP LED for port 6 are shown in Figure 12.

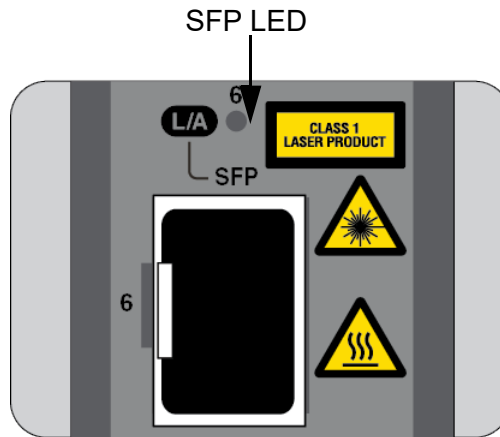

Figure 12. IS130-6GP SFP LED: Port 6

The descriptions of the SFP LEDs are defined in Table 6.

Table 6. SFP Slot LED

State	Description
Solid Green	The port has established a 100Mbps or 1Gbps link to a network device.
Flashing Green	The port is transmitting or receiving network packet traffic at 100Mbps or 1Gbps.
Off	The port has not established a link to a network device.

## PoE Status LEDs

The PoE Status LEDs are shown in a separate group from the PoE ports themselves.

The IS230-10GP PoE Status LEDs for Copper ports 1-8 are shown in Figure 13.

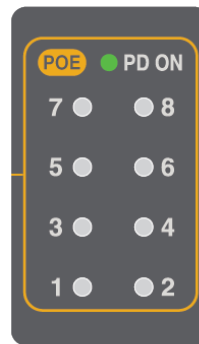

4415

Figure 13. IS230-10GP PoE Status LEDs: Ports 1-8

The IS130-6GP PoE Status LEDs for Copper ports 1-4 are shown in Figure 14.



4506

Figure 14. IS130-6GP PoE Status LEDs: Ports 1-4

The PoE LED functional descriptions for the Copper ports are listed in Table 7.

Table 7. PoE Status LED Descriptions

<b>LED</b>	<b>State</b>	<b>Description</b>
PoE	Solid Green	PoE is active on the port and is delivering power to a powered device.
	Off	This LED state indicates one of the following conditions: <ul style="list-style-type: none"><li>- The port is connected to a non-PoE device.</li><li>- The PD is powered off.</li><li>- PoE is disabled on the port.</li></ul>

## Power Supplies

---

Allied Telesis does not sell power supplies for the IS Series products. Power supplies can be purchased from power supply manufacturers.

---

### Note

See “Power Specifications” on page 101 for the DC power supply output requirements.

---

### IS230-10GP

The IS230-10GP switch has two +24-48VDC power inputs. The switch requires a UL61010 or UL61010-2-201 and 60950-1 or 62368-1 Listed DC power source, rated 24-48VDC, 7A minimum and Tma 75° C up to 3000m. If you need further assistance, please contact Allied Telesis.

*Le commutateur IS230-10GP prend en charge les entrées d'alimentation +24-48VDC. Le commutateur doit être alimenté à l'aide d'un adaptateur fourni par un UL61010 ou UL61010-2-201 et 60950-1 ou 62368-1 Source d'alimentation CC répertoriée, calibrée 24-48VDC, 7A minimum et Tma entre 75° C et 3000m. Si vous avez besoin d'aide supplémentaire, veuillez contacter Allied Telesis.*

Here are the power supply requirements for the IS230-10GP switch:

- ❑ DC voltage between 24 and 48VDC.  
*Tension continue entre 24 et 48VDC.*
- ❑ The DC power supply must be capable of supplying 7A continuously over the operating temperature range of -40° C to 75° C (-40° F to 167° F).  
*L'alimentation CC doit être capable de fournir 7A en continu dans la plage de températures de fonctionnement de -40° C à 75° C (-40° F à 167° F).*

### IS130-6GP

This IS130-6GP switch has two +48-54VDC power inputs. The switch requires a IEC/EN/UL 62368-1 listed power source, rated 48VDC, 2.5A minimum or 54VDC, 2A minimum and Tma 75° C up to 3000m. If you need further assistance, please contact Allied Telesis.

*Ce commutateur IS130-6GP prend en charge les entrées d'alimentation +48-54VDC. Le commutateur doit être alimenté en utilisant une source d'alimentation homologuée IEC/EN/UL 62368-1, de calibre 48VDC, 2.5A minimum ou 54VDC, 2A minimum et Tma 75° C jusqu'à 3000m. Si vous avez besoin d'aide supplémentaire, veuillez contacter Allied Telesis.*

Here are the power supply requirements for the IS130-6GP switch:

- ❑ 48V, 2.5A (per port 15W) (+18.75%/-6.25%)  
OR  
54V, 2A (per port 30W) (+5.55%/-5.55%)  
48V, 2.5A (*par port 15W*) (+18.75%/-6.25%)  
OU  
54V, 2A (*par port 30W*) (+5.55%/-5.55%)
- ❑ The DC power supply must be capable of supplying the above current continuously over the operating temperature range of -40° C to 75° C (-40° F to 167° F).  
*L'alimentation CC doit être capable de fournir 7A en continu dans la plage de températures de fonctionnement de -40° C à 75° C (-40° F à 167° F).*

**Power Supply Redundancy**

A single power supply that meets the above requirements can fully power the switch. A second power supply can also be connected for power redundancy.

**Power Supply Connections**

Power supplies are connected to four of the six terminals on the power/alarm connector on the top panel of the chassis. Refer to Figure 7 on page 38.

Each power supply is connected to the switch with two wires, one positive (+) and one negative (-). If you are installing only one power supply to the switch, you may connect it to either the PWR 1 (V1+,V1-) or PWR 2 (V2+,V2-) pins.

---

**Note**

See for “Power Connector Pinout Assignments” on page 106 for the pinout function assignments.

---

## Chapter 2

# Begin Installation

---

The chapter contains the following sections:

- “Review Safety Precautions” on page 48
- “Safety Precautions With Electricity” on page 54
- “Review Site Requirements” on page 55
- “Verify Package Contents” on page 57

## Review Safety Precautions

---

Please review the following safety precautions before you begin to install the switches

**Important:** Safety statements that have the  symbol are translated into multiple languages in the *Translated Safety Statements* document, which is available at [www.alliedtelesis.com/library](http://www.alliedtelesis.com/library).

**Remarque:** Les consignes de sécurité portant le symbole  sont traduites dans plusieurs langues dans le document *Translated Safety Statements*, disponible à l'adresse [www.alliedtelesis.com/library](http://www.alliedtelesis.com/library).



**Caution**

CAUTION: FOR USE IN A CONTROLLED ENVIRONMENT

**ATTENTION:** *Pour utilisation dans un environnement contrôlé*

---



**Warning**

Do not block air ventilation holes.

**ATTENTION:** *Ne bloquez pas les ou es de ventilation.*

---



**Warning**

Use dry cloth for cleaning.

**ATTENTION:** *Utilisez un chiffon sec pour le nettoyage.*

---



**Warning**

This is open type equipment and should be installed in a suitable enclosure.

**ATTENTION:** *Ceci est un appareil de type ouvert et doit être installé dans une enceinte appropriée.*

---

## Ground Connection

Please review the following safety information and installation guidelines before installing the ground connection. Refer to “Connect Ground Wire” on page 76 for the installation procedure.



### Caution

Before connecting the power, properly ground the device. Lack of a proper grounding setup may result in a safety risk and could be hazardous.

*Avant de brancher l'appareil, mettez correctement l'appareil à la terre. L'absence d'une mise à la terre correcte peut entraîner un risque de sécurité et être dangereux.*

## Power/Alarm Connection

Please review the following safety information and installation guidelines before installing the power and alarm wires. Refer to “Power/Alarm Connector Cables” on page 81 for the installation procedure.



### Warning

Power cord is used as a disconnection device. To de-energize equipment, disconnect the power cord. ⚡ E3

*Le cordon d'alimentation est utilisé en tant que mécanisme de déconnexion. Pour mettre l'équipement hors tension, débrancher le cordon d'alimentation. ⚡ E3*

## Safety Instructions

### IS230-10GP

The IS230-10GP switch can be powered with a SELV +24-48VDC. All circuits should be connected to a SELV circuit.

- ❑ Make sure the voltage of the power source is correct before connecting the equipment to the power source.
- ❑ If the equipment is not used for a long time, remove it from the power source to avoid damage by transient over voltage.
- ❑ For use in pollution degree 2 environments and indoor use.
- ❑ If the equipment is used in a manner not specified by the manufacturer, the protection provided by the equipment may be impaired.

*Le commutateur IS230-10GP peut être alimenté en utilisant une tension SELV + 24-48 Vcc. Tous les circuits doivent être connectés à un circuit SELV.*

- ❑ *Assurez-vous que la tension de la source d'alimentation est correcte avant de connecter l'équipement à la source d'alimentation.*

- ❑ *Si l'équipement n'est pas utilisé pendant une longue période, retirez-le de la source d'alimentation pour éviter tout dommage dû à une surtension transitoire.*
- ❑ *Pour une utilisation dans des environnements de degré de pollution 2 et à l'intérieur.*
- ❑ *Si l'équipement est utilisé d'une manière non spécifiée par le fabricant, la protection fournie par l'équipement peut être altérée.*

### **IS130-6GP**

The IS130-6GP switch supports +48-54VDC power inputs.

- ❑ The switch requires a IEC/EN/UL 62368-1 listed power source, rated 48VDC, 2.5A minimum or 54VDC, 2A minimum and Tma 75° C up to 3000m.
- ❑ Ensure to connect the power cord to a socket-outlet with earthing connection.
- ❑ If the equipment is not used for a long time, remove it from the power source to avoid damage by transient over voltage.
- ❑ For use in pollution free environments and indoor use.
- ❑ Never open the equipment. For safety reasons, the equipment should be opened only by qualified service personnel.
- ❑ Use only EN 60825-1 certified Optical Fiber Transceivers with a maximum operating temperature specification that is equal to or greater than 75° C.
- ❑ This equipment is not suitable for use in locations where children are likely to be present.

*Les commutateurs peuvent être alimentés en utilisant SELV +48-54VDC.*

- ❑ *Les commutateurs doivent être alimentés en utilisant une source d'alimentation répertoriée IEC/EN/UL 62368-1, nominale de 48VDC, 2.5A minimum ou 54VDC, 2A minimum et Tma de 75° C à 3000m.*
- ❑ *Branchez correctement le câble de raccordement à la terre à la prise de l'appareil*
- ❑ *Si l'appareil n'est pas utilisé pendant une longue période, retirez-le de l'alimentation électrique pour éviter d'endommager la surtension momentanée.*
- ❑ *Pour une utilisation dans des environnements non polluant et à l'intérieur.*
- ❑ *N'ouvrez jamais l'équipement. Pour des raisons de sécurité, l'appareil ne devrait être ouvert que par un personnel de service qualifié.*

- ❑ *Utilisez uniquement des émetteurs-récepteurs à fibre optique certifiés EN 60825-1 dont la température de fonctionnement maximale est égale ou supérieure à 75° C.*
- ❑ *Cet appareil ne doit pas être utilisé dans des endroits où se trouvent des enfants.*

## Safety Statements

The following safety statements apply to the IS Series switch products:



### Warning

Class 1 Laser product. ⚡ L1



### Warning

Do not stare into the laser beam. ⚡ L2



### Warning

Do not look directly at the fiber optic ends or inspect the cable ends with an optical lens. ⚡ L6



### Warning

To prevent electric shock, do not remove the cover. No user-serviceable parts inside. This unit contains hazardous voltages and should only be opened by a trained and qualified technician. To avoid the possibility of electric shock, disconnect electric power to the product before connecting or disconnecting the LAN cables. ⚡ E1



### Warning

Do not work on equipment or cables during periods of lightning activity. ⚡ E2



### Warning

Power cord is used as a disconnection device. To de-energize equipment, disconnect the power cord. ⚡ E3



### Warning

This equipment must be earthed. The ground screw on the unit must be connected to a properly earthed bonding point.

---

**Note**

Ground resistance from the building primary bonding point to earth should be less than 5 ohms.

---

---

**Note**

All Countries: Install product in accordance with local and National Electrical Codes. ⚡ E8

---



**Warning**

Only trained and qualified personnel are allowed to install or replace this equipment. ⚡ E14

---



**Caution**

Air flow around the unit and through the cooling fins must not be restricted. ⚡ E20

---



**Caution**

Circuit Overloading: Consideration should be given to the connection of the equipment to the supply circuit and the effect that overloading of circuits might have on overcurrent protection and supply wiring. Appropriate consideration of equipment nameplate ratings should be used when addressing this concern. ⚡ E21

---



**Warning**

This unit might have more than one power cord. To reduce the risk of electric shock, disconnect all power cords before servicing the unit. ⚡ E30

---



**Warning**

To reduce the risk of electric shock, do not route network cables from PoE ports outside the building that houses this device. ⚡ E40

---



**Caution**

The unit does not contain serviceable components. Please return damaged units for servicing. ⚡ E42

---

**Warning**

The temperature of an operational SFP or SFP+ transceiver can exceed 70° C (158° F). Exercise caution when handling transceivers with unprotected hands. ⚡ E43

**Caution**

An Energy Hazard exists inside this equipment. Do not insert hands or tools into open chassis ports or plugs. ⚡ E44

**Warning**

This equipment shall be installed in a Restricted Access location. ⚡ E45

**Warning**

**HOT SURFACE, DO NOT TOUCH**  
**ATTENTION: SURFACE CHAUDE, NE PAS TOUCHER.**

**Warning**

Hot surface! The finned surface on the back of the chassis is a heat sink and can become dangerously hot. ⚡ E114

**Warning**

Per NEC section 800.90 all exposed cables, service wires, or drops entering a building must have primary over-voltage protection if they are classified as exposed plants.

**Note**

The equipment meets EN61000-4-5 Class 3 on the DC inputs and Ethernet ports.

**Warning**

Allied Telesis does not warrant against lightning or power surges causing damage the device. Such damage will be the responsibility of the equipment owner.

## Safety Precautions With Electricity

---

Please review the following additional safety guidelines before beginning the installation procedure.

- Disconnect all power by turning off the circuit breakers before installing or removing the device or when working with the power supplies.
- Do not work alone if potential hazards exist.
- Never assume that the power is disconnected from a circuit; always check the circuit.
- Inspect the work area carefully for possible hazards, such as moist floors, ungrounded power extension cables, frayed power cord, or missing safety grounds.

If an electrical accident occurs, proceed as follows:

- Use caution; do not become a victim yourself.
- Turn off power to the system.
- If possible, send another person to get medical aid. Otherwise, access the condition of the victim and then call for help.
- Determine if the person needs rescue breathing or external cardiac compressions and take appropriate action.

## Review Site Requirements

---

Please observe the following requirements and guidelines when choosing a site for the IS Series switch:

- ❑ You can install the switch on a concrete or masonry wall or industrial panel or DIN 35x7.5mm rail.
- ❑ The DC power source should be located near the device and be easily accessible.
- ❑ The site should allow for easy access to the ports on the front of the device, so that you can easily connect and disconnect cables, and view the port LEDs.
- ❑ The site should allow for adequate air flow around and through the cooling fins on the sides of the switch.
- ❑ The site should not expose the device to moisture or water.
- ❑ The site should be a dust-free environment.
- ❑ The site should include dedicated power circuits or power conditioners to supply reliable electrical power to the network devices.
- ❑ If you are installing the device in a wiring or utility box, verify that the enclosure has adequate airflow so that unit does not overheat.
- ❑ Do not place objects on top of the switch.
- ❑ The Copper cabling should not be exposed to sources of electrical noise, such as radio transmitters, broadband amplifiers, power lines, electric motors, and fluorescent lights.
- ❑ The site should allow for the following minimum open spaces around the switch:
  - Four inches under the switch.
  - Eight inches above the switch.
  - Four inches in front of the switch.
  - One inch on the left and right sides of the switch.
- ❑ Before installing the DC power supply, be sure to review the manufacturer's installation guide for rules and restrictions on site requirements, and to follow all guidelines and safety warnings.
- ❑ The switch and DC power source should be installed close to each other so that the DC power cables are kept as short as possible to minimize voltage loss.
- ❑ The switch and power supply should be properly connected to a protective earth ground.
- ❑ The switch and power supply should be individually grounded to the grounding conductor. Do not daisy-chain the ground wires.

- ❑ Powered devices connected to the LAN ports on the switch should be grounded to the same grounding conductor at the service entrance as the switch.
- ❑ LAN ports should have additional lightning protections as specified in 803.3at Section 33.4.1.1.2, Environment B Requirements, when connected to powered devices that are not grounded to the same grounding conductor at the service entrance as the switch.
- ❑ Electromagnetic interference might occur between switches and other devices when multiple switches are powered by a single DC power supply. This can be addressed by installing clamp-on ferrite beads on the DC power cables, between the DC power supply and switches.
- ❑ Recommendations for ground resistivity are given in Table 8.

Table 8. Ground Resistivity Recommendations

<b>Level</b>	<b>Recommendation</b>
Best Practice	<5 ohms
Acceptable	5 to 15 ohms
Marginal	15 to 25 ohms
Non-compliant	>25 ohms

## Verify Package Contents

Figure 15 identifies the pre-installed components on the front panel of the IS230-10GP switch.

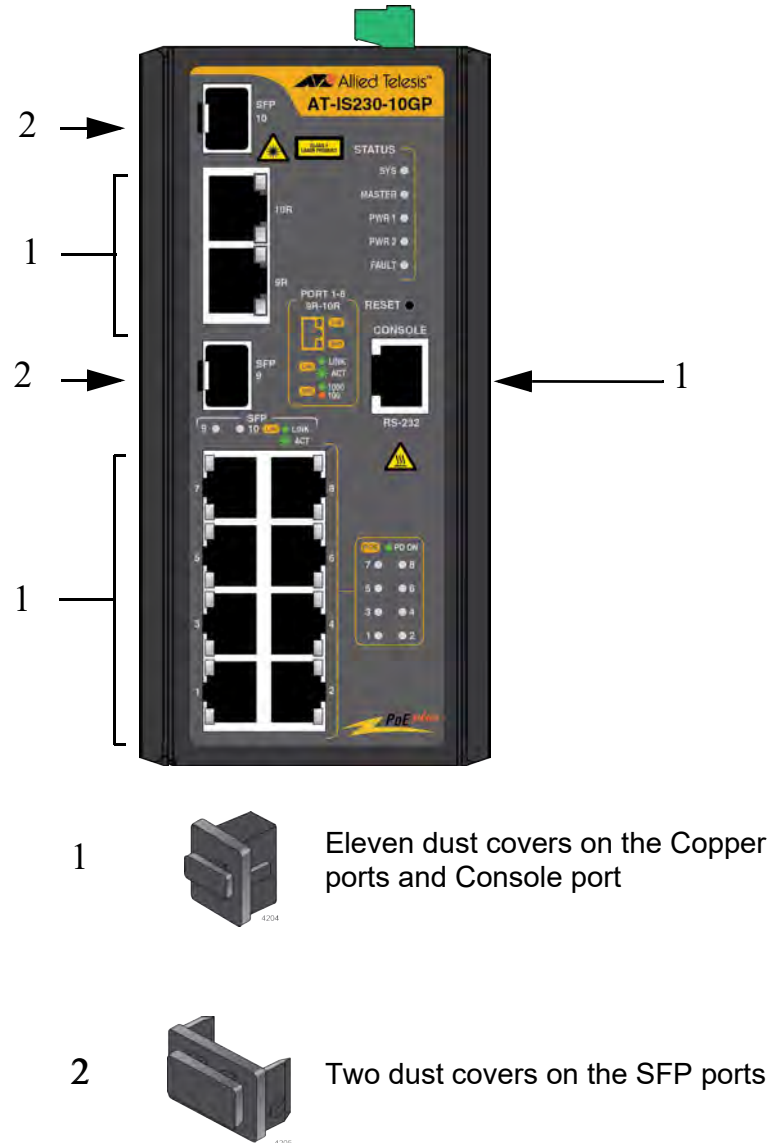

Figure 15. Pre-installed Components on the IS230-10GP Front Panel

Figure 16 identifies the pre-installed components on the front panel of the IS130-6GP switch.

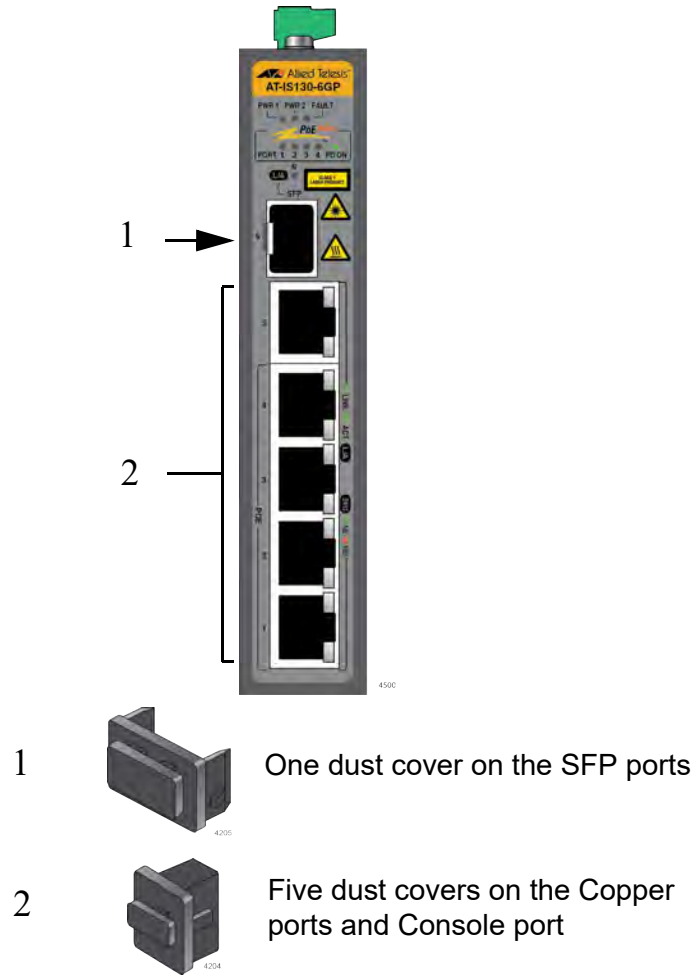

Figure 16. Pre-installed Components on the IS130-6GP Front Panel

The Power/Alarm connector and the grounding screw locations are identified in Figure 17.

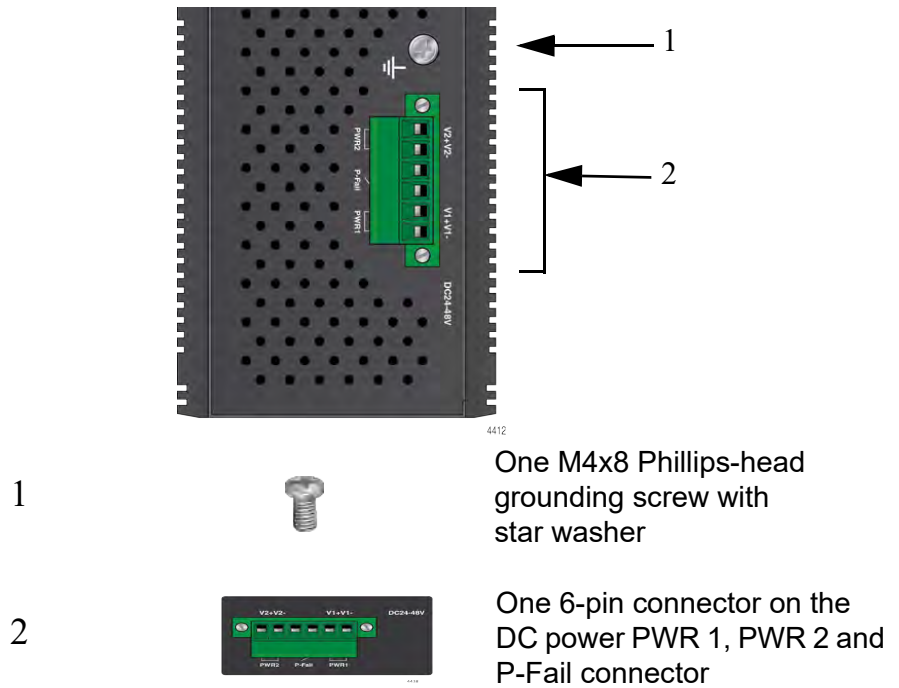

Figure 17. Pre-installed Components on the Top Panel

Figure 18 identifies the pre-installed DIN rail bracket on the back panel.

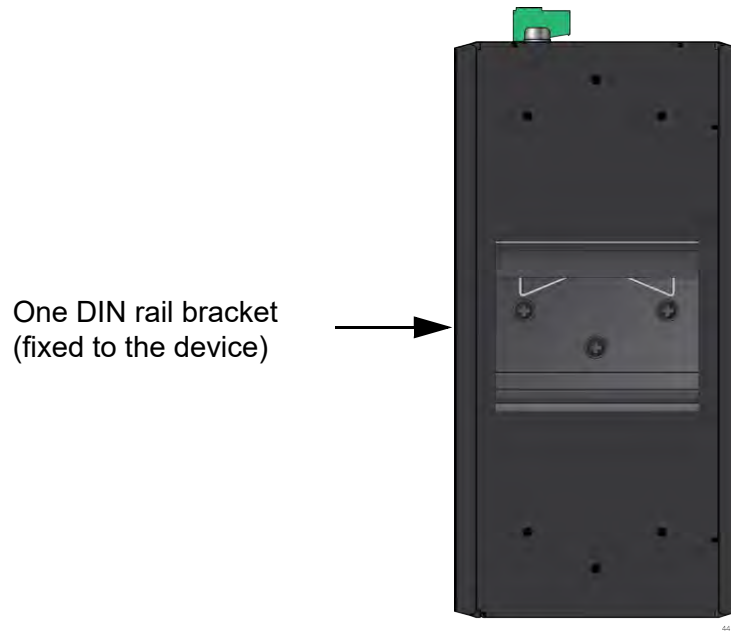

Figure 18. Pre-installed DIN Rail Bracket on the Back Panel

Figure 19 lists the items included in the accessory kit that comes with the IS230-10GP switch.

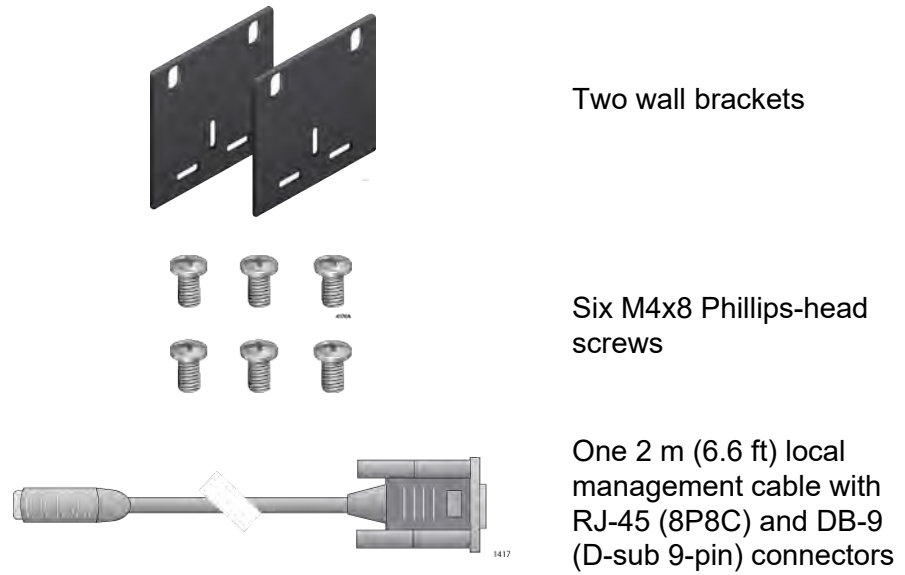

Figure 19. IS230-10GP Accessory Kit Components

Figure 19 lists the items included in the accessory kit that comes with the IS130-6GP switch.

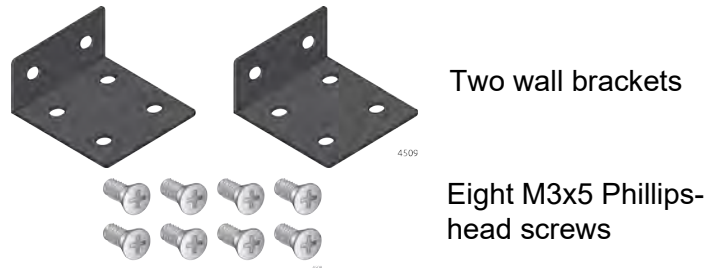

Figure 20. IS130-6GP Accessory Kit Components

## Chapter 3

# Install the Switch

---

The procedures in this chapter are listed here:

- “DIN Rail Installation” on page 62
- “Install Switch On Concrete or Masonry Wall or Industrial Panel” on page 64

## DIN Rail Installation

---

Both IS Series switches come with a DIN rail bracket pre-installed on the back panel. The bracket is compatible with a DIN 35x7.5mm rail. The bracket has a spring built into it which holds the bracket in place.

---

### Note

Figure 21, Figure 22, and Figure 23 below illustrate the IS230-10GP switch, but also apply to the IS130-6GP switch.

---

Figure 21 shows the proper orientation of the switch on a DIN rail. Do not install the switch horizontally or upside-down.



Figure 21. Orientation of the Switch on a DIN Rail

To install the switch on a DIN rail, perform the following procedure:

1. Slide the slot on the top of the DIN rail bracket onto the top edge of the DIN rail. Refer to Figure 22 on page 63.

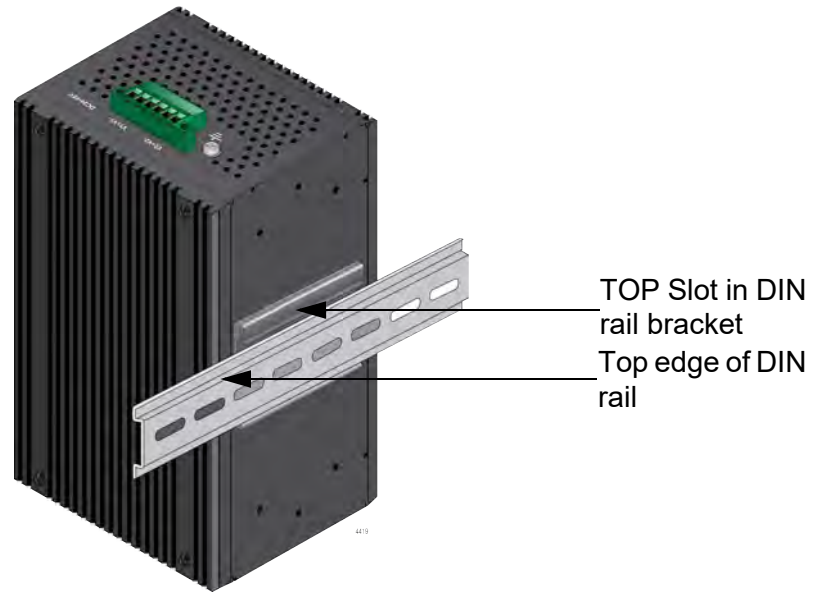

Figure 22. Install Top Slot of DIN Rail Bracket onto DIN Rail

2. Press down against the spring within the bracket on the top back edge of the switch until you the bottom edge of the front faceplate of the switch can be pushed back and under the bottom edge of the DIN rail. Release the pressure on the top of the switch until the DIN rail bracket spring securely fastens bracket to the top and bottom of the DIN rail. Refer to Figure 23.

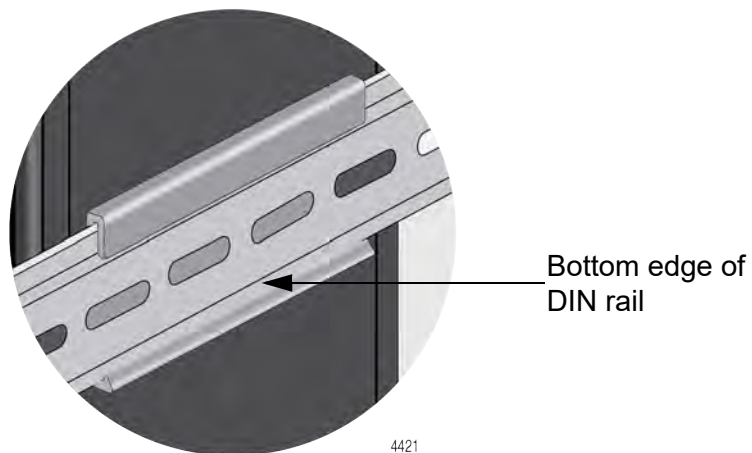

Figure 23. Install Switch on DIN Rail

3. Visually inspect the bracket to verify that the DIN rail is now fitted into the top and bottom ports of the DIN rail bracket.
4. Go to Chapter 4, “Install Copper Port Cables” on page 69.

## Install Switch On Concrete or Masonry Wall or Industrial Panel

---

This section contains instructions on how to install the switch on a concrete or masonry wall or industrial panel.



### Warning

The device is heavy. Always ask for assistance before moving or lifting it to avoid injuring yourself or damaging the equipment.

---



### Warning

The device should be installed on a wall or an industrial panel by a qualified building contractor. Serious injury to yourself or others or damage to the equipment may result if it is not properly fastened.

---

Here are the tools and material required for installing the switch on a concrete or masonry wall or industrial panel:

- Two wall brackets (included in the switch accessory kit)
- Wall bracket mounting screws - eight M3x5mm - length, 5 mm (included in the switch accessory kit)
- Cross-head screwdriver (not provided)
- Drill and 1/4" carbide drill bit (not provided)
- Four anchors and screws (not provided) for attaching the switch to the wall or panel. The diameter of the screw holes in the wall brackets is 4.5 mm (0.17 in.).

---

### Note

A DIN-Rail bracket is factory-installed and attached to the device with three screws (size M3x5mm - length, 5 mm). This bracket must be removed prior to mounting the device on the wall. Refer to the wall installation procedure below.

---

To install the switch on a concrete or masonry wall or industrial panel, perform the following procedure:

1. Place the switch in a table.
2. Remove the DIN rail mounting bracket that is factory-installed on the back panel of the switch. Refer to Figure 24 on page 65.



Figure 24. Remove Din Rail Mounting Bracket

3. On the IS130-6GP top and bottom panels and the IS230-10GP back panel, align and install the two wall mounting brackets (provided) with the bracket mounting screws (provided). Refer to Figure 25.

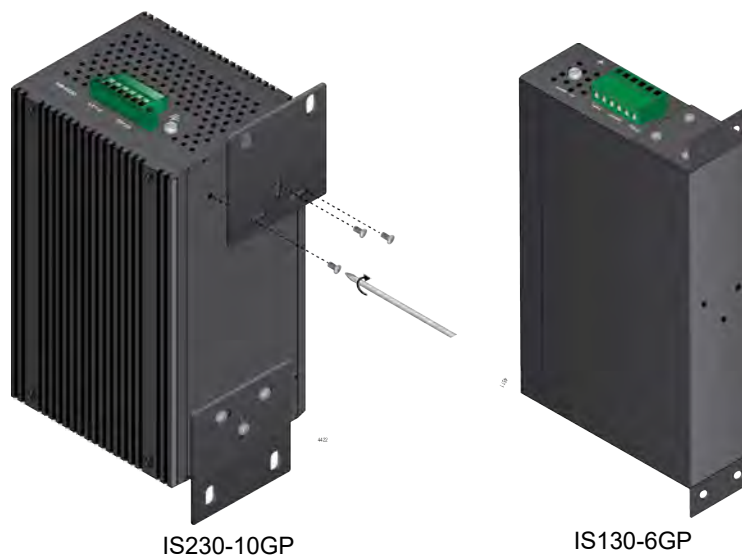

Figure 25. Install Wall Mount Brackets on the Back of the Switch

4. Hold the switch on the concrete or masonry wall or industrial panel at the selected location for the device while you use a pencil or pen to mark the locations of the four screw holes in the two wall brackets. Refer to Figure 26.

Please follow these guidelines as you position the switch on the wall or industrial panel:

- ❑ The switch must be oriented as shown in Figure 26. You may not install the switch horizontally or upside-down.
- ❑ Be sure to leave sufficient space from other devices or walls to allow for adequate air circulation around and through the cooling fins. Refer to “Review Site Requirements” on page 55 for further information.



Figure 26. Mark Wall Bracket Hole Locations

5. If you are installing the switch on an industrial panel, skip this step and go to Step 6.

If you are installing the switch on a masonry or concrete wall, perform this step as follows:

- a. Use a drill and 1/4" carbide drill bit to drill the four holes at the locations marked in Step 4. Please review the following guidelines:
    - Prior to drilling, set the drill to hammer and rotation mode. The modes break up the concrete and clean out the hole.
    - Allied Telesis recommends cleaning out the holes with a brush or compressed air.
  - b. Insert anchors (not provided) into the four holes.
  - c. Go to Step 6.
6. Hold the switch at the selected location while you secure it with four screws (not provided). Refer to Figure 27.

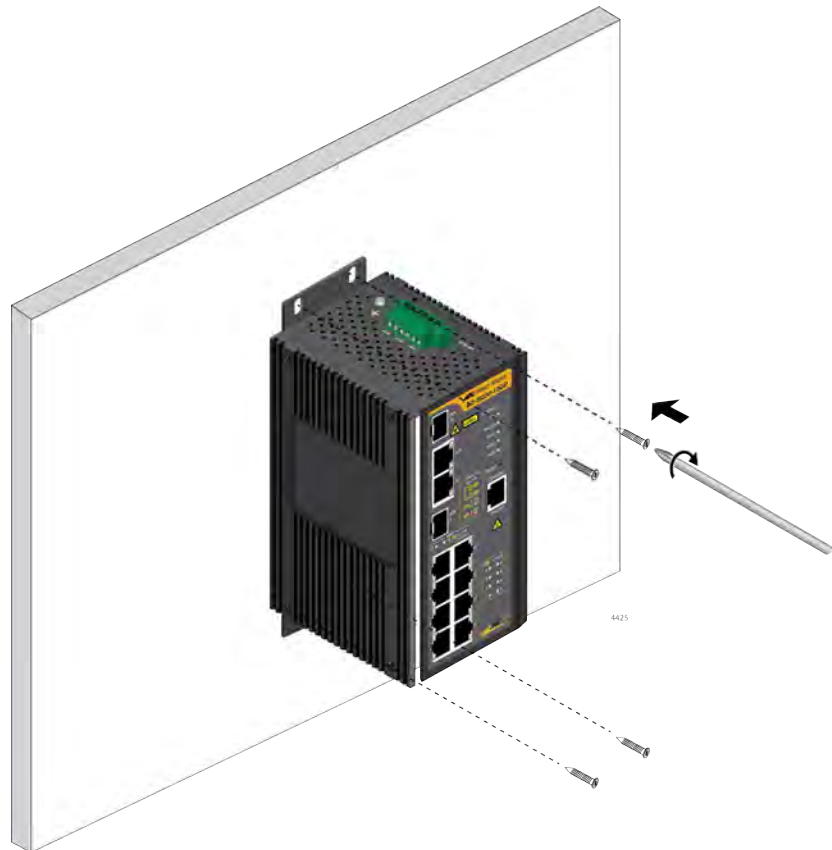

Figure 27. Install Switch Using Wall Brackets

7. Go to Chapter 4, "Install Copper Port Cables" on page 69.



## Chapter 4

# Install Copper Port Cables

---

This chapter contains the following procedures:

- “Copper Port Cables” on page 70
- “Install SFP Transceivers and Fiber Cables” on page 71

## Copper Port Cables

---

Here are the guidelines to cabling the 10/100/1000Base-T Copper ports:

- ❑ The ports have 8-pin RJ45 connectors.
- ❑ The connectors on the cables should fit snugly into the ports, and the tabs should lock the connectors into place.
- ❑ The 10/100/1000Base-T ports must be set to Auto-Negotiation, the default setting, to operate at 1000Mbps.
- ❑ The default duplex mode setting for the ports is Auto-Negotiation. This setting is appropriate for ports connected to network devices that also support Auto-Negotiation for duplex modes.
- ❑ The default duplex mode setting of Auto-Negotiation is not appropriate for ports connected to network devices that do not support Auto-Negotiation and have a fixed duplex mode. Disable Auto-Negotiation on those ports and set their duplex modes manually to avoid the possibility of duplex mode mismatches. A switch port using Auto-Negotiation defaults to half-duplex if it detects that the end node is not using Auto-Negotiation. This can result in a mismatch if the end node is operating at a fixed duplex mode of full-duplex.
- ❑ The default wiring configuration of the ports is automatic MDIX detection, which configures the MDI/MDIX setting automatically. This setting is appropriate for switch ports that are connected to network devices that also support the feature.
- ❑ Refer to “Copper Cable Requirements” on page 102 for the cable requirements.

---

### Note

The default setting for PoE on the ports on the IS230-10GP and IS130-6GP switches is enabled. You cannot disable PoE on the IS130-6GP switch.

---

## Install SFP Transceivers and Fiber Cables

---

Please review the following guidelines before installing SFP transceivers in the IS Series switches:

- ❑ SFP transceivers are hot-swappable. You may install them while the device is powered on.
- ❑ For a list of supported transceivers, refer to the product data sheet.
- ❑ The operational specifications and fiber optic cable requirements of the transceivers are provided in the documents included with the devices.
- ❑ You should install a transceiver before connecting its fiber optic cable.
- ❑ Fiber optic transceivers are dust sensitive. Always keep the plug in the optical bores when a fiber optic cable is not installed, or when you store the transceiver. When you do remove the plug, keep it for future use.
- ❑ Unnecessary removal and insertion of a transceiver can lead to premature failure.
- ❑ Installing or removing a transceiver from a slot in the switch might require slightly more force than typically required with other network equipment. This is because of the design of the SFP cages.



### Warning

A transceiver can be damaged by static electricity. Be sure to observe all standard electrostatic discharge (ESD) precautions, such as wearing an antistatic wrist strap, to avoid damaging the device. ⚡ E86

---

The illustrations in the following procedure show a transceiver with a duplex LC connector installed in a IS230-10GP switch. The connectors on your transceivers may be different.

To install SFP transceivers in the chassis, perform the following procedure:

1. Remove the dust plug from a transceiver slot. Refer to Figure 28.

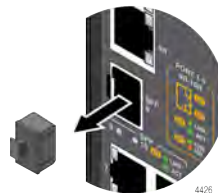

Figure 28. Remove the Dust Plug from an SFP Slot

2. Remove the transceiver from its shipping container and store the packaging material in a safe location.
3. Position the transceiver with its handle on the right and slide it into the slot until it clicks into place. Refer to Figure 29.

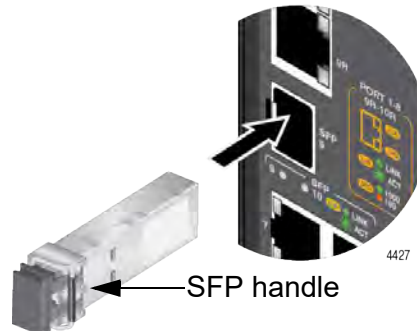

Figure 29. Install SFP Transceiver

---

**Note**

If you are ready to attach the fiber optic cable to the transceiver, continue with the next step. Otherwise, for the IS230-10GP switch, repeat steps 1 to 3 to install the other transceiver in the switch.

---

4. Remove the dust cover from the transceiver. Refer to Figure 30.

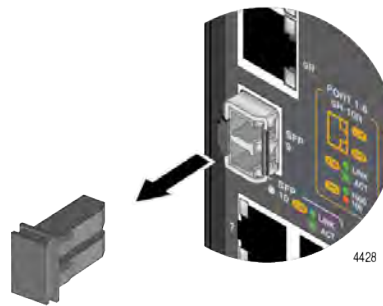

Figure 30. Remove Dust Cover from SFP Transceiver

5. Connect the fiber optic cable to the transceiver. The connector on the cable should fit snugly into the port, and the tab should lock the connector into place. Refer to Figure 31.

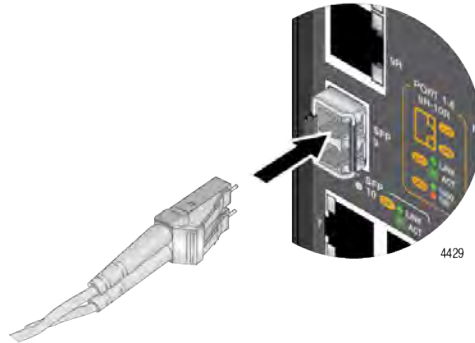

Figure 31. Connect Fiber Optic Cable To SFP Transceiver

6. For the IS230-10GP switch, repeat this procedure to install and connect the cable to the other SFP transceiver if required.
7. Go to Chapter 5, "Power On Switch" on page 75.



## Chapter 5

# Power On Switch

---

This chapter contains the following procedures:

- ❑ “Connect Ground Wire” on page 76
- ❑ “Power/Alarm Connector Cables” on page 81
- ❑ “Apply Power To Switch” on page 86
- ❑ “Start Management Session” on page 87

## Connect Ground Wire

---

Here are the guidelines for the ground wire:



---

### Warning

Take into consideration the following guidelines before wiring the device.

*Attention*

*Tenez compte des directives suivantes avant de câbler l'appareil.*

- The terminal block (CN1) is suitable for 12-18 AWG (7A). Torque value 7 lb-in.  
*Le bornier (CN1) est adapté pour 12-18AWG (3,31-0,205mm<sup>2</sup>). Valeur de Torgue 7lb-in.*
- The cross sectional area of the earthing conductors should be at least 0.205 mm.  
*Le min. La section du conducteur de protection doit correspondre au conducteur de puissance dans une plage de 3,31-0,205 mm<sup>2</sup>.*
- The temperature rating of the input connection cable should be higher than 105° C.  
*La température nominale du câble de connexion d'entrée doit être supérieure à 105° C.*



---

### Warning

This equipment must be earthed. The ground screw on the unit must be connected to a properly earthed bonding point.

---

Here are the guidelines for the grounding wire:

- The wire should be minimum #16 AWG solid wire.
- The wire length should be as short as possible.
- Continuity from the grounding screw to the earth ground must be less than 0.05 ohms.
- If a terminal is used, it should be double crimped.



---

### Warning

This equipment must be earthed. The ground screw on the unit must be connected to a properly earthed bonding point.  E120

---

To connect the grounding wire with bare wire, perform the following procedure:

1. Strip 2.54cm (1.0 in.) of insulation from the end of the solid grounding wire with a wire insulator stripper. Refer to Figure 32.

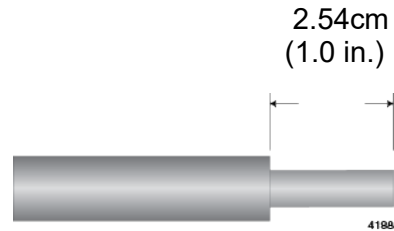

Figure 32. Stripping the Grounding Wire



**Warning**

Do not strip more than the recommended amount of wire. Stripping more than the recommended amount can create a safety hazard by leaving exposed wire on the terminal block after installation. ⚡ E10

2. Slide a heat-shrink tube over the grounding wire. Refer to Figure 33

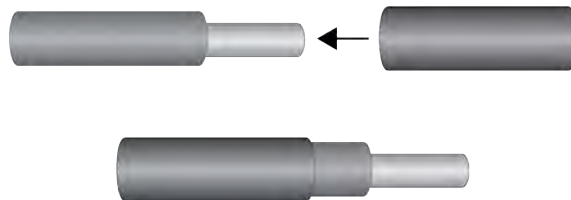

Figure 33. Sliding a Heat-shrink Tube Over the Grounding Wire

- Slide the ring terminal lug over the stripped wire on the grounding wire. Refer to Figure 34.

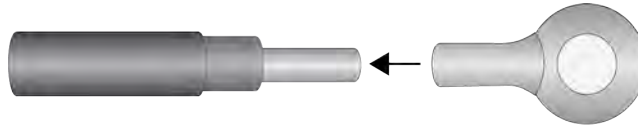

Figure 34. Sliding the Ring Terminal Lug on the Grounding Wire

- Crimp the ring terminal lug with a wire crimping tool to secure it on the grounding wire. Refer to Figure 35.

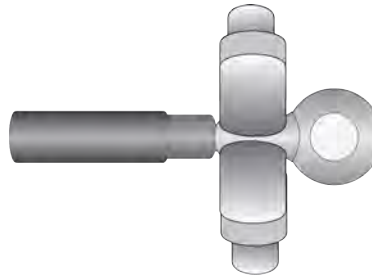

Figure 35. Crimping the Ring Terminal Lug

- Slide the heat-shrink tube over the shaft of the ring terminal lug. Refer to Figure 36.

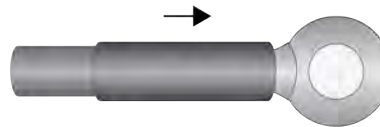

Figure 36. Sliding the Heat-Shrink Tube Over the Ring Terminal Lug

- Heat the heat-shrink tube to secure it on the wire and ring terminal lug. Refer to Figure 37.

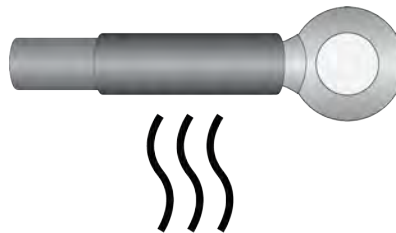

Figure 37. Heating the Heat-Shrink Tube

7. Remove the grounding screw from the switch with a #2 Phillips-head screwdriver. Refer to Figure 38.

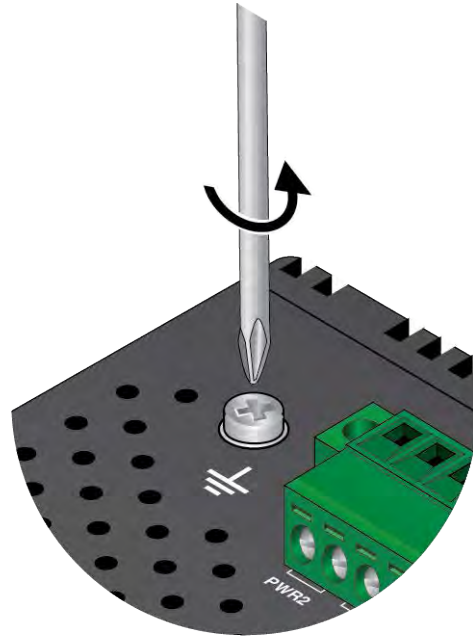

Figure 38. Removing the Grounding Screw

8. Secure the grounding wire to the switch with the grounding screw. Refer to Figure 39.

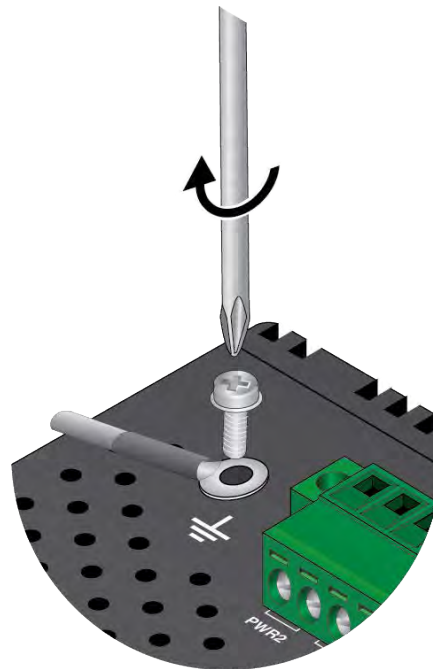

Figure 39. Attaching the Grounding Wire to the Switch

9. Connect the other end of the grounding wire to a ground point at the installation site.
10. Go to “Power/Alarm Connector Cables” on page 81.

## Power/Alarm Connector Cables

The materials and tools needed to install the DC power and alarm cables are provided by the user and are as follows:

- ❑ 12-18 AWG stranded wires
- ❑ 6-wire connector for the power and alarm cables connections
- ❑ #1 flat-head screwdriver
- ❑ Wire insulation stripper

Review the following guidelines before wiring the device:

- ❑ The IS230-10GP switch supports dual +24-48VDC power inputs
- ❑ The IS130-6GP switch supports dual +48-54VDC power inputs
- ❑ Tighten wire-clamps to a torque value 7 in-lb. to prevent the DC wires from loosening
- ❑ The terminal block is suitable for 12-18 AWG (3.31 - 0.205 mm<sup>2</sup>)
- ❑ P-Fail contacts are a dry relay contact that can alert you to switch problems. Refer to “P-Fail Alarm Relay Contacts” on page 38.



### Warning

The circuit breaker is used as the disconnection device. To de-energize equipment, shut down the circuit breaker and then disconnect the input wires. *See* E38

### Power/Alarm Connector Wiring

To make the two pairs of DC power cables and one pair of wires for the P-Fail alarm relay contacts, perform the following procedure:

1. Strip 6.5mm (0.25 in.) of insulation from the ends of each of power and the alarm wires with a wire insulator stripper. Refer to Figure 40.

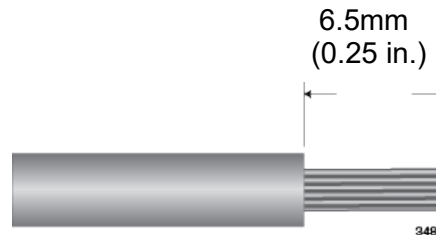

Figure 40. Strip Power or Alarm Wire



---

**Warning**

Do not strip more than the recommended amount of wire. Stripping more than the recommended amount can create a safety hazard by leaving exposed wire on the terminal block after installation. *E10*

---

2. Tightly wrap the wire strands with your finger tips. Refer to Figure 41.

This step is to prevent loose strands from touching other wires and causing an electrical short.

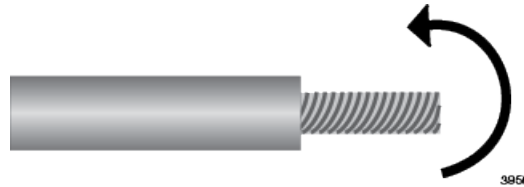

Figure 41. Wrap Wire Strands

---

**Note**

Allied Telesis recommends tinning the wires with solder as added protection against loose strands. This guide does not provide instructions on how to tin wires.

---

3. On the IS230-10GP switch, loosen the two fastening screws on the sides of the Power/Alarm connector.

---

**Note**

The IS130-6GP switch Power/Alarm connector does not have fastening screws.

---

4. Remove the power/alarm connector from the top panel. Figure 42 shows the removal of this connector.

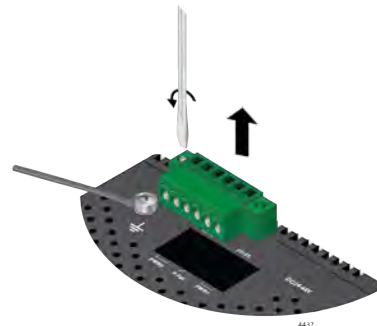

Figure 42. Remove Power/Alarm Connector

- With a #1 screwdriver, loosen the screws that correspond to the appropriate connectors.

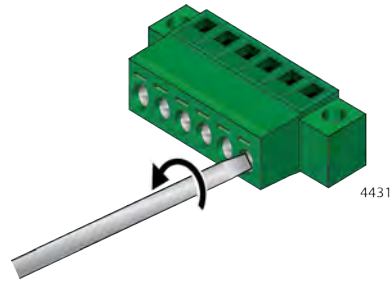

Figure 43. Loosen Power/Alarm Connector Wire Retaining Screws

- Insert the power wires into the wiring slots for V1+ and V1- for the first power supply. If you are installing the wires for a second power supply, insert them into wiring slots V2+ and V2-. Insert the two alarm wires in the two middle wiring slots - pins 3 and 4. There is no polarity for the alarm wires. Refer to Figure 44.

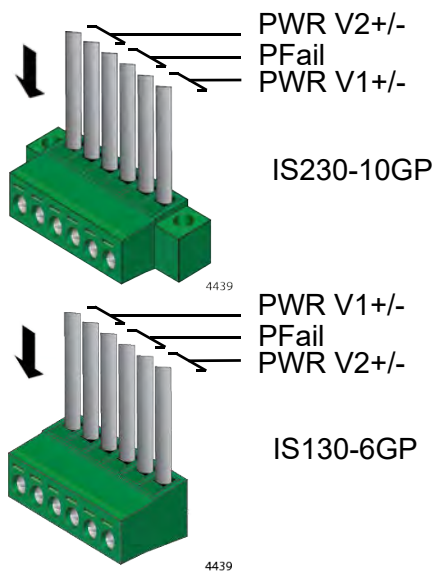

Figure 44. Insert Power Supply and Alarm Wires into Power/Alarm Connector

- After inserting the wires to the connector, verify that there are no exposed wires or loose wire strands. Refer to Figure 45 on page 84.



**Warning**

Check to see if there are any exposed copper strands coming from the installed wires. When this installation is done correctly there should be no exposed copper wire strands extending from the terminal block. Any exposed wiring can conduct harmful levels of electricity to persons touching the wires. ⚡ E12

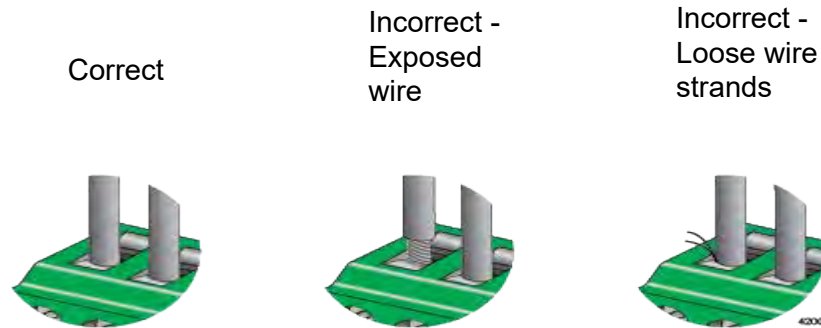

Figure 45. Verify Wire Installation

8. Tighten the retaining screws on the power/alarm connector to secure the wires to a torque value 7 in.-lb Refer to Figure 46.

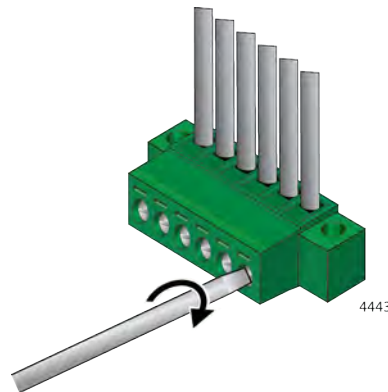

Figure 46. Tighten Wires In Power/Alarm Connector

9. Connect the opposite ends of the alarm wires to the external alarm circuit.
10. Connect the opposite ends of the “plus” and “minus” power wires from the power/alarm connector to the first external DC power supply. Refer to the documentation included with the power supply unit for instructions.
11. If you have a second external power supply, connect the second pair of power wires from the power/alarm connector to the second DC power supply. Refer to the documentation included with the power supply unit for instructions.

12. Insert the power/alarm connector into the mating connector on the chassis top panel.

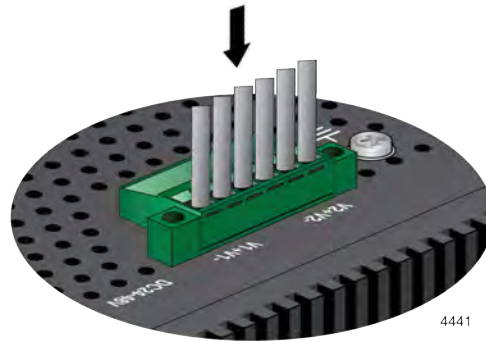

Figure 47. Insert the Power/Alarm Connector

13. On the IS230-10GP switch, tighten the two connector fastening screws on the ends of the power/alarm connector to the chassis as shown in Figure 48.

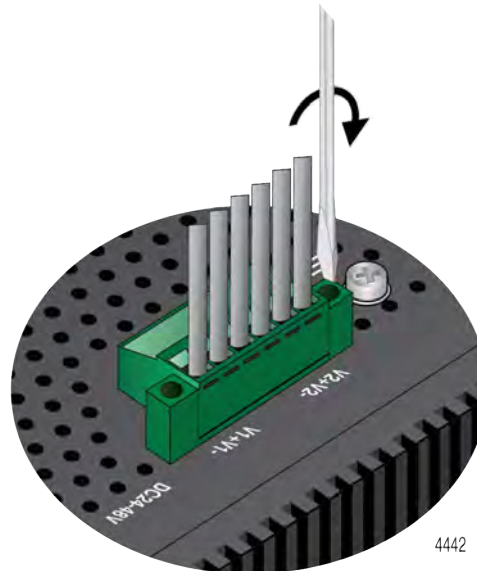

Figure 48. Fasten the Power/Alarm Connector to Chassis

14. After inserting and fastening the power/alarm connector, go to “Apply Power To Switch” on page 86.

## Apply Power To Switch

---

This section contains the procedure for powering on the switch.

To power on the chassis, perform the following procedure:

1. Apply power to the DC power supplies.

---

**Note**

The IS230-10GP and IS130-6GP switches do not have On/Off switches. To turn the units OFF, you must turn OFF the power supplies.

---

2. Wait a minimum of one minute for the switch to initialize its operating system.

### Verify Switch Operations

Here are items to check to verify that the switch is operating normally. If there is a problem, refer to Chapter 6, “Troubleshooting” on page 91 for suggestions on how to resolve it.

- The Fault LED should be off.
- One or both PWR 1 and PWR 2 LEDs should be solid green, depending on the number of DC power supplies connected to the unit.
- The LEDs on SFP slots with transceivers connected to active network devices should be solid or flashing green.
- The Link LEDs on copper ports connected to active network devices should be solid or flashing green or amber. The Link LEDs are identified in Figure 9 on page 41 and Figure 11 on page 42.
- The PoE LEDs should be solid green on ports that are connected to PoE or PoE+ devices. The PoE LEDs are identified in Figure 13 on page 43.

If you have a IS230-10GP switch, go to “Start Management Session” on page 87.

## Start Management Session

---

The initial management session for the IS230-10GP switch may be conducted via a local session by connecting to the Console port or over a network connection on any of the Ethernet ports of the switch.

### Local Management Session

This section contains the procedure for starting a local management session on the switch. Please review the following information before performing the procedure:

- Local management sessions are conducted through the Console port on the front panel.
- Local management sessions do not interfere with the network operations of the switch.
- The switch comes with one 2 m (6.6 ft) management cable, with RJ-45 and DB-9 connectors, for local management sessions. Refer to Figure 19 on page 60.
- The switch does not need an IP address for local management sessions.
- The Command Line Interface (CLI) is the only management interface available when using the Console port.
- The Simple Network Management Protocol (SNMP) is available via the CLI interfaces.

To start a local management session, perform the following procedure:

1. Connect the RJ-45 connector on your management cable to the Console port on the switch.
2. Connect the other end of the cable to an RS-232 port on a terminal or personal computer with a terminal emulation program.
3. Configure the VT-100 terminal or terminal emulation program as follows:
  - Baud rate: 9600 bps (The baud rate of the Console port is adjustable from 1200 to 115200 bps. The default is 9600 bps.)
  - Data bits: 8
  - Parity: None
  - Stop bits: 1
  - Flow controller: None

---

#### Note

The port settings are for a DEC VT100 or ANSI terminal, or an equivalent terminal emulator program.

---

4. Press Enter. You are prompted for the name and password of the manager account.
5. Enter the username and password. The default values are **manager** and **friend**, respectively.

---

**Note**

The username and password are case sensitive.

---

The switch starts the local management session and displays the following prompt:

```
awp1us>
```

This prompt represents the User Exec mode in the command line interface in the switch. Refer to the IS230-10GP Switch Reference Guide for the available CLI commands.

## Network Management Session

This section contains the procedure for starting the IS230-10GP management session via a network connection. Please review the following information before performing the procedure:

- A network management session may be established via any of the Ethernet ports of the switch.
- A network management session shares the Ethernet connection with active network traffic.
- The switch needs an IP address for a network management session. The factory default IP address is 192.168.1.1.
- The Web and Command Line Interface (CLI) management interfaces are available over a network connection.
- The Simple Network Management Protocol (SNMP) is available on both the Web and CLI management interfaces.

To start a network management session, perform the following procedure:

1. Connect your computer to one of the Ethernet ports on the switch.
2. Change the IP address on your computer to 192.168.1.n, where "n" is any number between 2 and 254.
3. If you choose to use the Web management interface, perform the following steps:
  - a. Launch your web browser on the computer.
  - b. In the browser's URL address bar, type the switch's default IP address (192.168.1.1).  
The login screen displays.
  - c. Enter the default username (**manager**) and password (**friend**).

---

**Note**

The user name and password are case sensitive.

---

- d. Click **OK** on the login screen to log in.  
The main web interface window is displayed.
4. If you choose to use the CLI management interface, perform the following steps:
  - a. Open a command prompt window and type:  

```
telnet <switchip> (where <switchip> is the IP address of the switch)
```

---

**Note**

The default switch IP address is 192.168.1.1.

---

- b. At the login prompt, type the default username (**manager**) and password (**friend**).  
The switch will respond with “Managed switch configuration CLI ready”.



## Chapter 6

# Troubleshooting

---

This chapter has suggestions on how to troubleshoot problems with the switch. The sections in the chapter are listed here:

- ❑ “PWR 1 and PWR 2 LEDs” on page 92
- ❑ “Copper Ports” on page 93
- ❑ “SFP Ports” on page 94
- ❑ “Power Over Ethernet” on page 95

---

**Note**

For further assistance, please contact Allied Telesis Technical Support at [www.alliedtelesis.com/support](http://www.alliedtelesis.com/support).

---

## PWR 1 and PWR 2 LEDs

---

**Problem:** A DC power supply is connected to the switch, but the corresponding PWR 1 or PWR 2 LED on the front panel is off.

**Solutions:** The unit is not receiving power from the power supply or the power is outside the operating range of the switch. Try the following:

- ❑ Verify that the DC power source is powered on and operating normally.
- ❑ Review the DC power source's documentation to verify that it is compatible with the switch. The power supply requirements for the switch are given in "Power Supplies" on page 45.
- ❑ Verify that the power/alarm connector is fully inserted into the slot in the top panel of the switch.
- ❑ Verify that the DC wires are securely connected to the PWR 1 - PWR 2 connector terminals on the switch and to the DC power supply.
- ❑ Verify that the DC positive and negative wires from the power supplies are connected to the correct connectors on the DC PWR 1 - PWR 2 connector terminals on the switch.
- ❑ Try using a different DC power source.
- ❑ Try replacing the DC power wires.
- ❑ Try connecting the DC power source to a different device to ensure that it is working properly.
- ❑ Test the output voltage from the power source to verify that it is within the operating range of the switch.

## Copper Ports

---

**Problem:** A Copper port on the switch is connected to a network device but the port's LINK/ACT LED is off.

**Solutions:** The port is unable to establish a link to a network device. Try the following:

- ❑ Verify that the port is connected to the correct Copper cable. This is to eliminate the possibility that the port is connected to the wrong network device which may not be active.
- ❑ Verify that the network device connected to the Copper port is powered on and is operating properly.
- ❑ Verify that the network cable is securely connected to the ports on the switch and remote network device.
- ❑ Try connecting another network device to the Copper port with a different cable. If the Copper port is able to establish a link, then the problem is with the cable or the other network device.
- ❑ Verify that the Copper cable does not exceed 100 meters (328 feet).
- ❑ Use the switch's management software to verify that the port is enabled.
- ❑ If the remote network device is a managed device, use its management firmware to verify that its port is enabled.

---

### Note

A 1000Base connection might require five to ten seconds to establish a link.

---

**Problem:** Network performance between a Copper port on the switch and a network device is slow.

**Solution:** There might be a duplex mode mismatch between the port and the network device. This can occur when a Copper port using Auto-Negotiation is connected to a remote device that has a fixed speed of 10 or 100 Mbps and a fixed duplex mode of full duplex. If this is the cause of the problem, adjust the duplex mode of the port on the network device or switch so that both ports are using the same duplex mode. For the AT-IS230-10GP switch, you have to use the management software to determine the duplex mode settings of the ports.

## SFP Ports

---

**Problem:** The LINK/ACT LED for an SFP transceiver is off.

**Solutions:** The fiber optic port on the transceiver cannot establish a link to a network device. Try the following:

- ❑ Verify that the remote network device connected to the fiber optic port is operating properly.
- ❑ Verify that the fiber optic cable is securely connected to the port on the SFP module and to the port on the remote network device.
- ❑ Check that the SFP transceiver is fully inserted in the slot in the switch.
- ❑ Verify that the operating specifications of the fiber optic ports on the transceiver and remote network device are compatible.
- ❑ Verify that the correct type of fiber optic cabling is being used.
- ❑ Verify that the port is connected to the correct fiber optic cable. This is to eliminate the possibility that the port is connected to the wrong remote network device.
- ❑ Try connecting another network device to the fiber optic port using a different cable. If the port is able to establish a link, then the problem is with the cable or with the other network device.
- ❑ On the IS230-10GP switch, use the switch's management software to verify that the port is enabled.
- ❑ If the remote network device is a managed device, use its management firmware to verify that its port is enabled.
- ❑ Test the attenuation of both directions on the fiber optic cable with a fiber optic tester to determine whether the optical signal is too weak (sensitivity) or too strong (maximum input power).

## Power Over Ethernet

---

**Problem:** The switch is not providing power to a powered device.

**Solutions:** Try the following:

- ❑ Check that the device's power requirements do not exceed those listed in Table 1 on page 29. The power requirements should be included in the device's documentation or data sheet.
- ❑ Try replacing the Copper cable.
- ❑ On the IS230-10GP switch, use the management software on the switch to determine whether PoE is enabled on the port. The default setting is enabled.
- ❑ On the IS230-10GP switch, use the PoE command to determine whether the PoE power setting for the port was reduced to a value below the power requirements of the device.
- ❑ Review the powered device's documentation to confirm that it is compliant with IEEE 802.3af or IEEE 802.3at Type 1 for PoE, or IEEE 802.3at Type 2 for PoE+. Legacy devices that are non-standard or were manufactured before the completion of the standards might not be compatible with the switches.
- ❑ For the IS130-6GP switch, verify that the powered device is not connected to port 5, which does not support PoE.
- ❑ Try connecting the device to a different port on the switch.



## Appendix A

# Technical Specifications

---

This appendix contains the following sections:

- “Physical Specifications” on page 98
- “Environmental Specifications” on page 100
- “Power Specifications” on page 101
- “Copper Cable Requirements” on page 102
- “RJ-45 Copper Ethernet Port Pinouts” on page 103
- “RJ-45 Style Serial Console Port Pinouts” on page 105
- “Power/Alarm Connectors” on page 106

# Physical Specifications

---

**Dimensions** Table 9 lists the dimensions of the products.

Table 9. Product Dimensions

IS230-10GP switch	74 x 105 x 152 mm (W x D x H) (2.91 x 4.13 x 5.98 in.)
IS130-6GP switch	30 x 95 x 140 mm (W x D x H) (1.18 x 3.74 x 5.51 in.)



Figure 49. IS230-10GP Switch Dimensions



Figure 50. IS130-6GP Switch Dimensions

**Weights** Table 10 lists the weights of the products.

Table 10. Product Weights

IS230-10GP switch	1.2 Kg (2.64 lb)
IS130-6GP switch	0.5 Kg (1.10 lb)

**Cabinet Dimensions** Table 11 provides the minimum cabinet dimensions.

Table 11. Minimum Cabinet Dimensions

Minimum Cabinet Dimensions (W x H x D)	50.8 x 50.8 x 30.5 cm (20.0 x 20.0 x 12.0 in)
---	--

# Environmental Specifications

---

Table 12 lists the IS Series environmental specifications.

Table 12. Environmental Specifications

Operating Temperature Range	-40° C to 75° C (-40° F to 167° F)
Storage Temperature	-40° C to 85° C (-40° F to 185° F)
Operating Humidity	10% to 95% noncondensing
Storage Humidity	10% to 95% noncondensing
Maximum Operating Altitude	3,000 m (9,843 ft)

## Power Specifications

---

Table 13 lists the maximum power consumption values.

Table 13. Maximum Power Consumption

IS230-10GP switch	13.2W (Full port load without PoE) 153.9W (Full port load, sourcing PoE)
IS130-6GP switch	14W @ 48Vdc (Full port load without PoE) 19.6W @ 54Vdc (Full port load without PoE) 74W @ 48Vdc (Full port load, sourcing PoE) 109.6W @ 54Vdc (Full port load, sourcing PoE)

Table 14 lists the external power supply DC output specifications.

Table 14. External Power Supply DC Output Specifications

Power Supply DC Output	IS230-10GP: 24 - 48Vdc, 7.0A IS130-6GP: 48Vdc, 2.5A or 54V, 2A
Operating Temperature Range	-40° C to 75° C (-40° F to 167° F)

Table 15 lists heat dissipation.

---

**Note**

The cooling requirements of the switch are smaller than the power draw because most of the load is dissipated at the PoE powered device (PD) and along the cabling. USE this BTU ratings for facility capacity planning.

---

Table 15. Heat Dissipation (British Thermal Units/Hour)

IS230-10GP switch	115.7 BTU/h @ 24Vdc 65.9 BTU/h @ 48Vdc
IS130-6GP switch	47.9 BTU/h @ 48Vdc 66.9 BTU/h @ 54Vdc

## Copper Cable Requirements

---

Minimum cable requirements for the copper ports are listed here:

- ❑ 10Mbps operations: Standard TIA/EIA 568-compliant Category 3, 100 ohm shielded or unshielded cabling, complying with IEEE 802.3i 10Base-T specifications.
- ❑ 100Mbps operations: Standard TIA/EIA 568-compliant Category 5, 100 ohm shielded or unshielded cabling, complying with IEEE 802.3u 100Base-TX specifications.
- ❑ 1Gbps operations: Standard TIA/EIA 568-compliant Category 5e, 100 ohm, 4-pair shielded or unshielded cabling, complying with IEEE 802.3ab 1000Base-T specifications. Category 5e is recommended.

---

**Note**

Category 3 and 5 cables may be used for EN55035 immunity levels.

---

---

**Note**

Category 6 or 6a shielded or unshielded cable is required in high RF noise environments.

---

## RJ-45 Copper Ethernet Port Pinouts

Figure 51 identifies pin 1 on an RJ-45 Copper port.

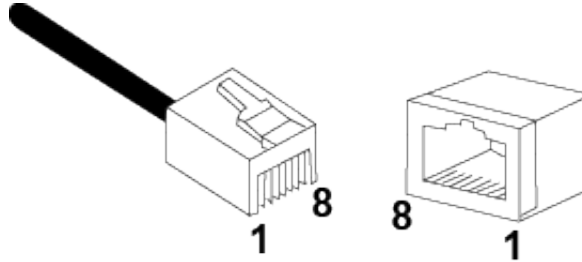

Figure 51. RJ-45 Port Pin Layout (Front View)

Table 16 lists the pin signals for a port when it is operating at 10 or 100 Mbps.

Table 16. Pin Signals for 10 and 100 Mbps

Pin	MDI Signal	MDI-X Signal
1	TX+	RX+
2	TX-	RX-
3	RX+	TX+
4	Not used	Not used
5	Not used	Not used
6	RX-	TX-
7	Not used	Not used
8	Not used	Not used

Table 17 lists the pin signals for a port when it operating at 1000 Mbps.

Table 17. Pin Signals for 1000 Mbps

<b>Pinout</b>	<b>Pair</b>
1	Pair 1 +
2	Pair 1 -
3	Pair 2 +
4	Pair 3 +
5	Pair 3 -
6	Pair 2 -
7	Pair 4 +
8	Pair 4 -

## RJ-45 Style Serial Console Port Pinouts

---

Table 18 lists the IS230-10GP Console port RJ-45 pin signals.

Table 18. Console Port Pin Signals

<b>Pin</b>	<b>Signal</b>
1	Open
2	Open
3	Transmit Data
4	Ground
5	Ground
6	Receive Data
7	Open
8	Ground

## Power/Alarm Connectors

**Pin Assignments** The IS Series pinout assignments for the power/alarm connector are shown in Figure 52.

Table 19. Power Connector Pinout Assignments

Assignment	Function
V1 +	PWR Supply 1 V+
V1 -	PWR Supply 1 V-
P-Fail	Alarm fault
P-Fail	Alarm fault
V2 +	PWR Supply 2 V+
V2 -	PWR Supply 2 V-



Figure 52. IS Series Power/Alarm Connectors

---

**Note**

For details of the power supply requirements, refer to “Power Supplies” on page 45.

---

**P-Fail Alarm Contact Rating**

The IS Series contact rating specifications for the P-Fail alarm relay are:

- ❑ 24VDC maximum
- ❑ 1.0A maximum