

## TQ6702 GEN2 Wireless Access Points

The access point models included in this Quick Installation guide are:

- ❑ AT-TQ6702 GEN2
- ❑ AT-TQ6702 GEN2-R
- ❑ AT-TQm6702 GEN2

### Note

The AT-TQ6702 GEN2-R wireless router shares the same chassis design with the AT-TQ6702 GEN2 and AT-TQm6702 GEN2 access points so that they look the same. To distinguish one model from the others, place a sticker with a model name on the plastic part of the device as necessary.

### Note

The TQ6702 GEN2-R is part of the TQR Series.

## Installation and User's Guides

This document contains an abbreviated version of the installation instructions for the TQ6702 GEN2 Wireless Access Points. For complete installation and management instructions, see the following documents:

- ❑ *Installation Guide for the TQ6702 GEN2 Access Point.*

For documentation about the TQ6702 GEN2, see:

- ❑ *User Guide: Management Software for TQ6000 GEN2 Wireless Access Points.*

For documentation about the TQ6702 GEN2-R, see:

- ❑ *Getting Started with the TQR Series Access Points and Wireless Routers*

Find more documentation on the Allied Telesis website at [www.alliedtelesis.com/library](http://www.alliedtelesis.com/library).

## Allied OneConnect Onboarding Service

The TQR Series features the OneConnect Onboarding service from Allied Telesis. The service automatically configures managed Allied Telesis products by downloading customized configuration packages from a regional cloud-based OneConnect Onboarding server.

### Please read the following before powering on the access point:

- ❑ TQR Series devices automatically start the OneConnect Onboarding service when it receives an IPv4 address from a DHCP server. The port and system LEDs will begin flashing after connecting with the cloud-based service and starting the download process.
- ❑ The access point automatically disables the OneConnect Onboarding service if it is not registered with the service.
- ❑ OneConnect Onboarding uses SZTP, NTP, DHCP, and DNS to contact its cloud-based server.

For information on Allied OneConnect Onboarding, consult your Allied Telesis Partner or refer to the *Allied OneConnect Onboarding Installation Guide* on the Allied Telesis website.



613-003195 Rev E

## Physical Description

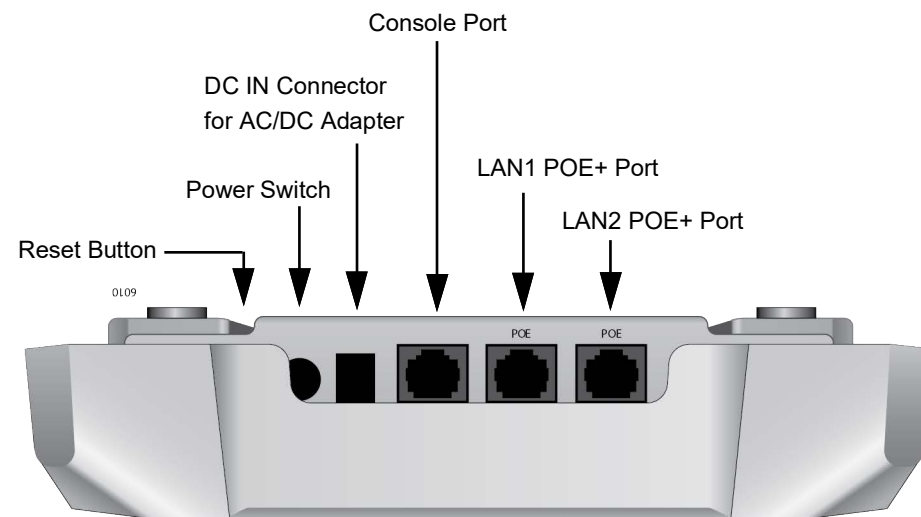

The Console ports on the TQ6702 GEN2 and TQm6702 GEN2 models are for manufacturing purposes only. For the TQ6702 GEN2-R device, you can access the AlliedWare Plus™ operating system through the Console port and configure the device.

## Safety Precautions and Site Requirements

Review the safety precautions and site requirements in the TQ6702 GEN2 *Wireless Access Points Installation Guide* before installing the device.

## Package Contents

The wireless access points come with the following items in the shipping container:

- ❑ One TQ6702 GEN2 Wireless Access Point
- ❑ This Quick Installation Guide
- ❑ One mounting bracket
- ❑ Two M5 x4.5 mm pan-head screws for the mounting bracket

If any item is missing or damaged, contact your Allied Telesis sales representative for assistance. You should retain the original shipping material in case you need to return the unit to Allied Telesis.

## Installation Options

You can install the access point on a desktop, ceiling, or wall. See the correct access point orientations:

### Desktop

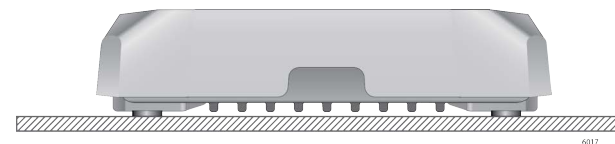

### Ceiling

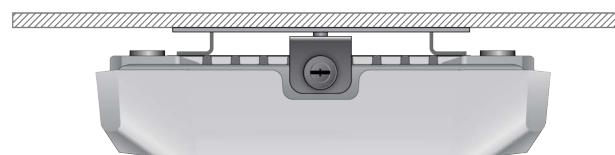

### Wall

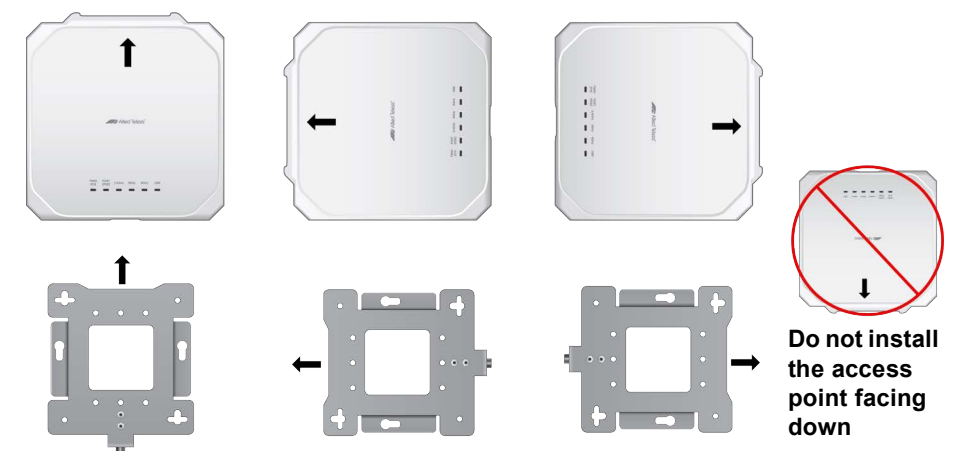

## Pre-fitting the Mounting Bracket

Before installing the mounting bracket on a wall or ceiling, pre-fit the bracket to the access point.

1. Place the access point upside down on a table.
2. Install the two screws (provided) fully into the bottom panel of the access point.

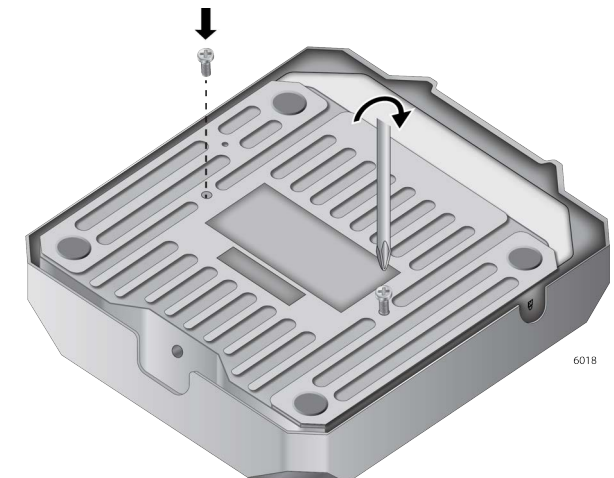

The screw collar provides the proper spacing for the mounting bracket beneath the screw head.



3. Make sure that the mounting bracket fits to the access point by sliding the bracket beneath the screws.



- Slide the mounting bracket forward and remove it from the access point.

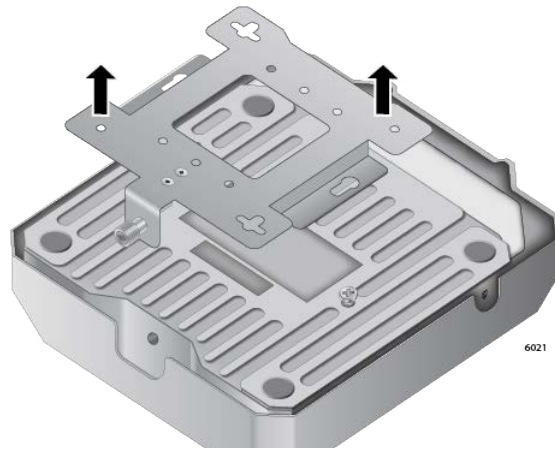

### Installing the Mounting Bracket on a Wall or Ceiling

- Choose a location and orientation for the access point on the wall or ceiling.
- Position the mounting bracket at the selected location for the access point. With a pencil, mark the two key-hole slots on the wall or ceiling.

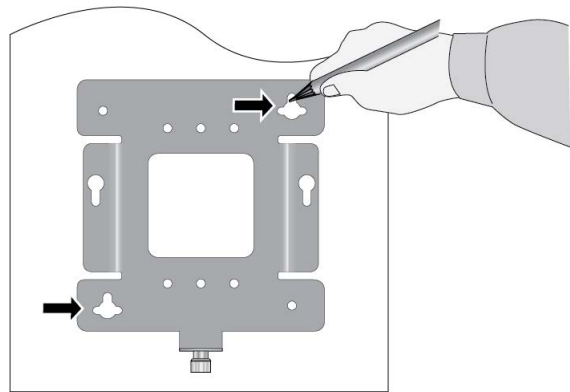

- If necessary, pre-drill on the wall or ceiling the two marked locations of the key-hole slots for the screws.
- Install two M4 screws and anchors (if required) into the wall or ceiling. Leave the screws loose enough so that you can slide the bracket under the screw heads. For wooden walls or ceiling, Allied Telesis recommends M4 25 mm flat-head wood screws and anchors (if required). The screws and anchors are not provided.

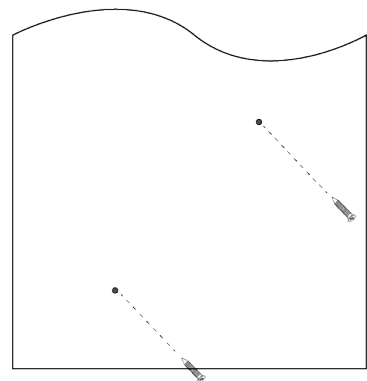

- Install the openings of the bracket key-hole slots to the two screw heads and slide the bracket into the narrow end of the key-hole slot openings.

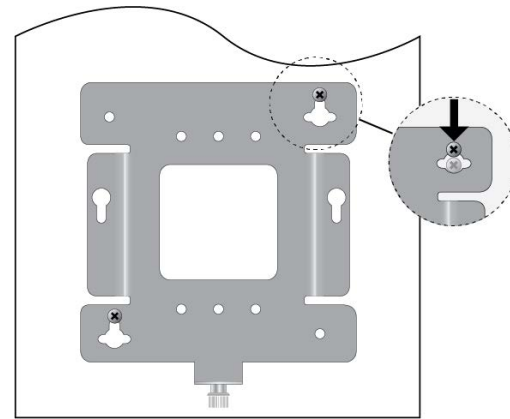

- Tighten the screws snugly onto the bracket.

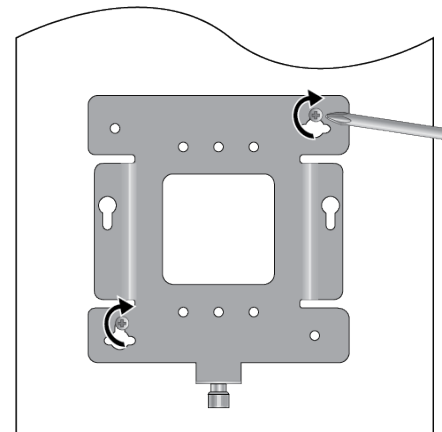

- To secure the mounting bracket, pre-drill holes through the two bracket mounting holes opposite the key-hole slots.

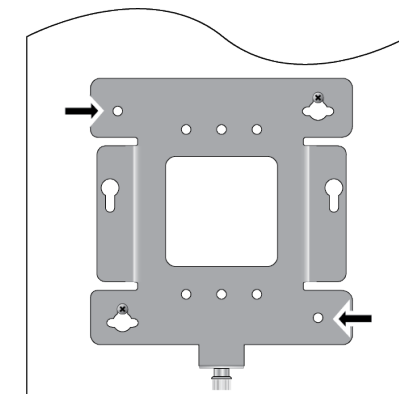

- Install and tighten two M4 screws (not provided).

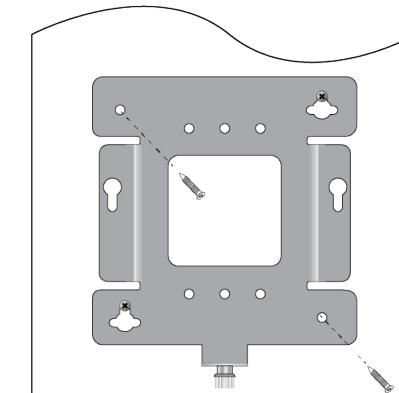

### Cabling the Wireless Access Point

Perform the following procedure to cable the Ethernet LAN port and to power the device:

- Connect an Ethernet cable to LAN1 (POE) port.

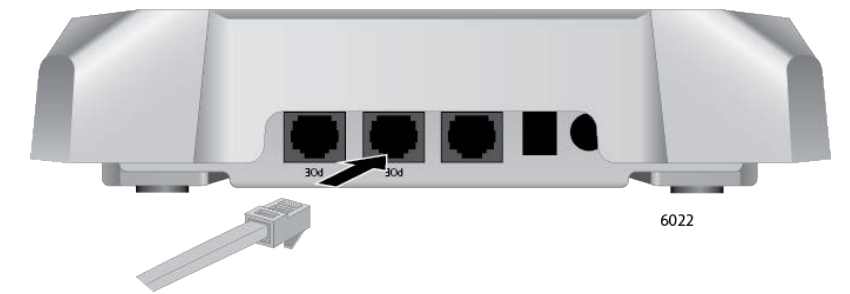

- Connect the other end of the Ethernet cable to a network device, such as a switch or router.

#### Note

When LAN1 port is connected to PoE+ power sourcing equipment, the TQ6702 GEN2 access point powers on and begins to initialize its management software.

- To use LAN2 port in the static LAG or Cascade mode, connect a second Ethernet cable to LAN2 port.

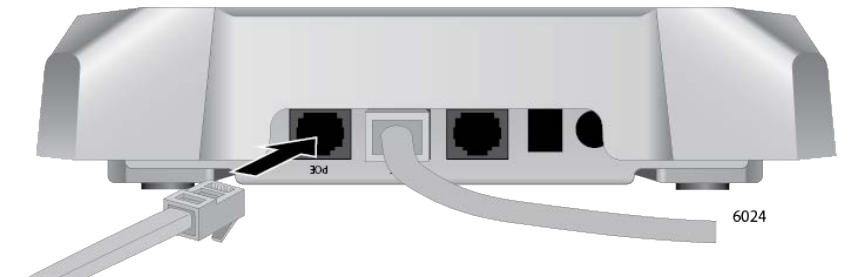

- Connect the other end of a network device. To use LAN2 port as a static LAG with LAN1 port, connect LAN2 to the same switch or router as LAN1 port. To use it in the Cascade mode, connect LAN2 to a different device.

#### Note

The default setting for LAN2 port is disabled. To enable the port, use the web management interface. For more details, see the TQ6702 GEN2 *Management Software User's Guide*.

#### Note

Do not enable the LAN2 port until you have configured the other network device for the static LAG.

### Powering the Wireless Access Point

The access point can be powered with PoE+ on the LAN1 or/and LAN2 ports, an external AC/DC power adapter, or both. The access point is powered by both PoE and an external power adapter uses the adapter as its primary power and PoE as redundant power.

Allied Telesis recommends the PWRADP-01 (DA-48Z12) AC/DC Power Adapter. The power adapter is ordered separately.

- Plug the DC connector into the DC IN jack on the access point.

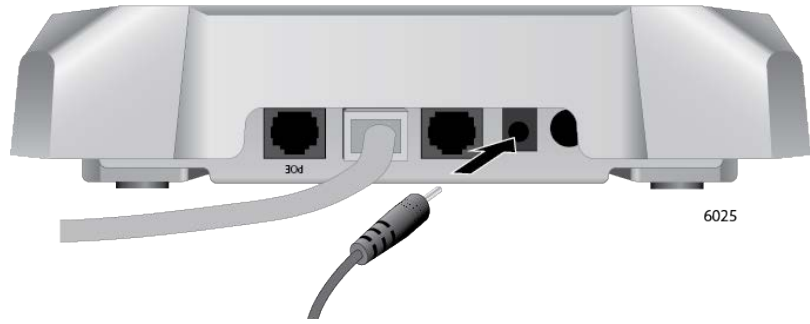

2. Connect the power adapter into an appropriate AC power source.
3. Turn on the Power Switch on the panel.

**Note**

The power switch on the access point controls power from the AC power supply. It does not control PoE+ on the LAN1 and LAN2 ports.

**Installing the Access Point on the Wall Mounting Bracket**

1. Align the bottom of the access point over the bracket so that the two screws on the bottom of the device fit into the bracket keyholes.

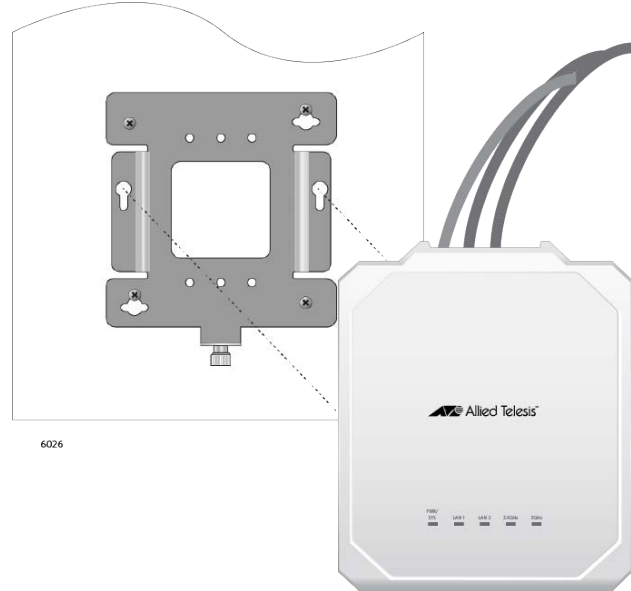

2. Slide the access point forward until its screws are seated in the bracket keyhole slots and the bracket thumbscrew is aligned with the screw hole on the front panel.
3. Tighten the thumbscrew to secure the access point to the wall mounting bracket.

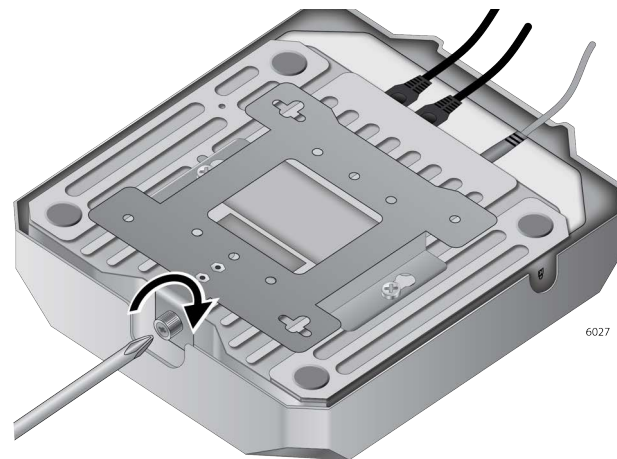

4. Place the Ethernet cable(s) and power cable (if any) along the cable guides inside of the top cover in the cable hiding space.

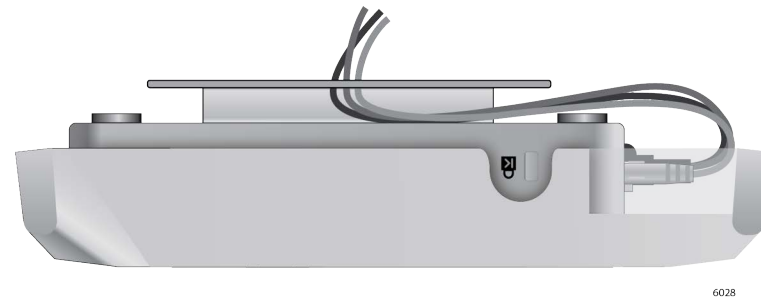

**Installing an Anti-theft Device**

Installation of an anti-theft cable/lock is optional.

**Note**

Anti-theft devices are not available from Allied Telesis.

1. Follow the instructions provided with the vendor's anti-theft device for the installation.



**Starting the Initial Management Session**

The access point firmware includes a DHCP client. The default setting for the client is enabled. When you power on the access point for the first time, it queries the subnet on the LAN port for a DHCP server. If a DHCP server responds to its query, the unit uses the IP address the server assigns to it.

If there is no DHCP server, the access point uses the default IP address:

- TQ6702 GEN2 and TQm6702 GEN2: 192.168.1.230
- TQ6702 GEN2-R: 192.168.1.1

To start the initial management session, perform the following procedure:

1. Start the web browser on your management workstation.
2. Enter the IP address of the wireless access point in the URL field of the web browser. The address is one of the following:
  - If your network does not have a DHCP server, enter the default IP address.
  - If your network has a DHCP server, enter the IP address the DHCP server assigned to the access point.

See the following screen as an example.

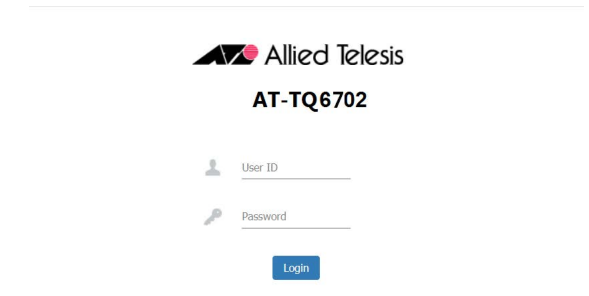

3. Enter "manager" for the username and "friend" for the password. The username and password are case-sensitive.

**Starting a Local Management Session for TQ6702 GEN2-R**

**Note**

This section is for the TQ6702 GEN2-R model only.

The TQ6702 GEN2-R device can be configured through a local session from the Console port in addition to the Web User Interface.

To start a local management session, perform the following procedure:

1. Connect the RJ-45 end of the management cable to the Console port on the TQ6702 GEN2-R device.
2. Connect the other end of the cable to an RS-232 port on a terminal or personal computer with a terminal emulation program.
3. Configure a terminal or terminal emulation program as follows:
  - Baud rate: 115200 bps
  - Data bits: 8
  - Parity: None
  - Stop bit: 1
  - Flow controller: None
  - Emulation: VT100

**Note**

The port settings are for a DEC VT100 or ANSI terminal, or an equivalent terminal emulator program.

4. Press Enter. You are prompted for a user name and password.
5. Enter "manager" for the username and "friend" for the password. The username and password are case-sensitive.

The local management session starts.



The AlliedWare™ Plus operating system is installed on the TQ6702 GEN2-R device.

**Setting the Country Setting**

The non-US model of this product has a country code setting that must be set during the initial management session of the unit. The setting ensures that the unit operates in compliance with the laws and regulations of your country or region.

The country code for the US model is preset and cannot be changed. Per FCC regulations, the country code setting for all WiFi products marketed in the US must be fixed to US operational channels only.

## LEDs

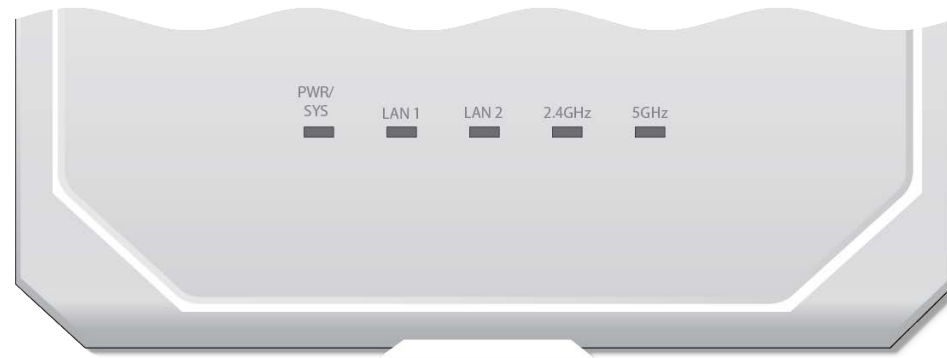

The top panel LEDs are described in this table.

LED Status Information

LED	State	Description	
		TQ6702 GEN2 & TQm6702 GEN2	TQ6702 GEN2-R
PWR/SYS	Green	The access point is powered on and operating normally.	
	Blinking Green	The access point is booting up.	N/A
	Red	The access point has encountered a fault condition.	The access point is booting up.
	Blinking Red	The access point is updating its firmware.	N/A
	OFF	The access point is not receiving power.	
LAN 1 and LAN 2	Green	The port has established a valid link to a network device.	
	Blinking Green	The port is transmitting or receiving data.	
	Amber	The port is connected to a PoE+ power sourcing equipment.	
	OFF	The port has not established a link to a network device.	
2.4GHz	Green	The 2.4GHz radio is enabled.	
	OFF	The 2.4GHz radio is disabled.	
5GHz	Solid Green	The 5GHz radio is enabled.	
	OFF	The 5GHz radio is disabled.	

## Product Specifications

The product specifications are listed in the following tables.

Physical Specifications

Parameter	Specification
Dimensions (W x D x H)	200 mm X 240 mm X 45 mm (7.9 in. x 9.4 in. x 1.8 in.)
Weight without mounting bracket	1.2 kg (2.6 lbs)

Physical Specifications

Weight with mounting bracket	1.4 kg (3.1 lbs)
------------------------------	------------------

Environmental Specifications

Parameter	Specification
Operating Temperature	0° C to 50° C (32° F to 122° F)
Storage Temperature	- 25° C to 70° C (- 13° F to 158° F)
Operating Humidity	0 % to 90% non-condensing
Storage Humidity	0 % to 95% non-condensing
Maximum Operating Altitude	3000 m (9843 ft)

Power Specifications on LAN Ports

Parameter	Specification
Maximum Power Consumption	25.5 watts
Rated Voltage	DC 48 A
Rated Current	0.67 A

External AC/DC Power Adapter Specifications

Parameter	Specification
Input Voltage Range	100~240 VAC
Input Frequency	50 - 60 Hz
Rated Output Voltage	+12 VDC
Rated Output Current	4 A
Temperature Ranges	0° C to 50° C (32° F to 122° F)
Maximum Operating Altitude	3000 m (9843 ft)

## Conformity and Regulatory Information

This device complies with Part 15 of FCC Rules, Directive 2014/53/EU issued by the Commission of the European Community, some other safety, electromagnetic emission, and radio certificates.

The operating frequencies and maximum transmission power levels for wireless devices operated in the EU & UK are listed below:

EU	Model: AT-TQ6702 GEN2-R			
	2412-2472 MHz	5150-5250 MHz	5250-5350 MHz	5470-5725 MHz
Beamforming	19.87 dBm	22.87 dBm	22.99 dBm	29.97 dBm
Non-Beamforming	19.94 dBm	22.99 dBm	22.96 dBm	29.83 dBm

UK	Model: AT-TQ6702 GEN2, AT-TQ6702 GEN2-R & AT-TQm6702 GEN2			
	2412-2472 MHz	5150-5250 MHz	5250-5350 MHz	5470-5725 MHz
Beamforming	19.87 dBm	22.87 dBm	22.99 dBm	29.97 dBm
Non-Beamforming	19.94 dBm	22.99 dBm	22.96 dBm	29.83 dBm

\* This equipment should be installed and operated with a minimum distance of 22 cm between the radiator and your body.

### Note

Contact Allied Telesis for the EU & UKCA conformity statement. To contact Allied Telesis, visit the web site at [www.alliedtelesis.com/contact](http://www.alliedtelesis.com/contact).

เครื่องวิทยุคมนาคมนี้ มีระดับการแผ่คลื่นแม่เหล็กไฟฟ้าสอดคล้องตามมาตรฐานความปลอดภัยต่อสุขภาพของมนุษย์จากการใช้เครื่องวิทยุคมนาคมที่คณะกรรมการกิจการโทรคมนาคมแห่งชาติประกาศกำหนด



เครื่องวิทยุคมนาคมนี้ ได้รับยกเว้น ไม่ต้องได้รับใบอนุญาตให้มี ใช้ซึ่งเครื่องวิทยุคมนาคมหรือตั้งสถานีวิทยุคมนาคมตามประกาศ กสทช. เรื่อง เครื่องวิทยุคมนาคม และสถานีวิทยุคมนาคมที่ได้รับยกเว้นไม่ต้องได้รับใบอนุญาตวิทยุคมนาคมตามพระราชบัญญัติวิทยุคมนาคม พ.ศ. 2498



โทรคมนาคม  
กำกับดูแลเพื่อประชาชน  
Call Center 1200 (Inswr)

## Singapore IMDA TS SRD

Complies with  
IMDA Standards  
DB102434

Copyright © 2026 Allied Telesis, Inc. All rights reserved.

No part of this publication may be reproduced without prior written permission from Allied Telesis, Inc.

Allied Telesis and the Allied Telesis logo are trademarks of Allied Telesis, Incorporated. All other product names, company names, logos or other designations mentioned herein are trademarks or registered trademarks of their respective owners.

Allied Telesis, Inc. reserves the right to make changes in specifications and other information contained in this document without prior written notice. The information provided herein is subject to change without notice. In no event shall Allied Telesis, Inc. be liable for any incidental, special, indirect, or consequential damages whatsoever, including but not limited to lost profits, arising out of or related to this manual or the information contained herein, even if Allied Telesis, Inc. has been advised of, known, or should have known, the possibility of such damages.