

# TQ7613-R

WIRELESS ACCESS POINT

AT-TQ7613-R

802.11be Tri-radio 2.4G/5G/6G Wireless AP



## Installation Guide

Copyright © 2026 Allied Telesis, Inc.

All rights reserved. No part of this publication may be reproduced without prior written permission from Allied Telesis, Inc.

Allied Telesis and the Allied Telesis logo are trademarks of Allied Telesis, Incorporated. All other product names, company names, logos or other designations mentioned herein are trademarks or registered trademarks of their respective owners.

Allied Telesis, Inc. reserves the right to make changes in specifications and other information contained in this document without prior written notice. The information provided herein is subject to change without notice. In no event shall Allied Telesis, Inc. be liable for any incidental, special, indirect, or consequential damages whatsoever, including but not limited to lost profits, arising out of or related to this manual or the information contained herein, even if Allied Telesis, Inc. has been advised of, known, or should have known, the possibility of such damages.

# Contents

---

<b>Preface</b> .....	<b>7</b>
Safety Symbols Used in this Document .....	8
Translated Safety Statements .....	9
Contacting Allied Telesis .....	10
<b>Chapter 1: Product Description</b> .....	<b>11</b>
Hardware Components .....	12
Antennas .....	14
Cable Hide .....	14
Console Port .....	14
Power Switch .....	14
USB Port .....	14
Kensington Lock Hole .....	15
Reset Button .....	15
PoE LAN Ports .....	16
Static Link Aggregation .....	16
Cascade Mode .....	17
Power Over Ethernet Plus (PoE++) .....	18
Connector Type .....	18
Speed .....	18
Duplex Mode .....	18
Automatic MDIX Detection .....	18
Cable Requirements .....	19
Maximum Distance .....	19
Port Pinouts .....	19
Guidelines .....	19
LEDs .....	20
<b>Chapter 2: Installing the Wireless Access Point</b> .....	<b>21</b>
Reviewing Safety Precautions .....	22
Unpacking the Shipping Box .....	24
Reviewing Installation Guidelines .....	25
Allied OneConnect Onboarding Service .....	27
Installing the Access Point on a Table .....	28
Overview to Installing the Access Point on a Wall or Ceiling .....	29
Pre-fitting the Mounting Bracket on the Access Point .....	30
Installing the Mounting Bracket on a Wall or Ceiling .....	32
Connecting Ethernet Cables to the LAN Ports .....	36
Guidelines .....	36
Connecting Ethernet Cables to the LAN Ports .....	36
Connecting the AC Power Adapter .....	38
Attaching the Access Point to the Mounting Bracket .....	39
Installing an Anti-theft Device .....	42
Starting the First Management Session .....	43
Starting a Local Management Session .....	45
<b>Appendix A: Technical Specifications</b> .....	<b>47</b>
Physical Specifications .....	47
Environmental Specifications .....	48
Power Specifications .....	48
External AC Adapter Specifications .....	48
PoE++ Power Requirements .....	49

Cable Specifications.....	49
LAN Port Specifications and Pinouts .....	50
Port Specifications.....	50
Port Pinouts .....	50
<b>Appendix B: Regulatory Statements .....</b>	<b>51</b>
European Union Restriction of the Use of Certain Hazardous Substances (RoHS) in Electrical and Electronic Equipment .....	52
Europe - EU Declaration of Conformity.....	53
Operating Frequencies and Maximum Transmission Power Levels .....	53
Radiation Exposure Statement.....	53
Importer .....	53
<b>Appendix C: Radiation Patterns .....</b>	<b>55</b>
Antenna Locations and Axes .....	56
Radiation Patterns for BLE/Zigbee.....	57
Radiation Patterns for Wi-Fi 2GHz.....	57
Radiation Patterns for Wi-Fi 5GHz.....	58
Radiation Patterns for Wi-Fi 6GHz.....	58

# Figures

---

Figure 1: Access Point Top View.....	12
Figure 2: Access Point Bottom View.....	12
Figure 3: Front Edge View.....	13
Figure 4: Back Edge View.....	13
Figure 5: Left Edge View.....	14
Figure 6: PORT1 and PORT2 Ports in a Static LAG.....	16
Figure 7: PORT2 Port in Cascade Mode with an End Node.....	17
Figure 8: PORT2 Port in Cascade Mode with a Networking Device.....	17
Figure 9: Top View - LEDs.....	20
Figure 10: Approved and Unapproved Orientations on a Ceiling, Wall, or Table.....	26
Figure 11: Attaching the Bracket Screws to the Access Point.....	30
Figure 12: Panel Screw.....	30
Figure 13: Attaching the Mounting Bracket on the Access Point.....	31
Figure 14: Removing the Mounting Bracket from the Access Point.....	31
Figure 15: Marking the Holes for the Keyhole Slots.....	32
Figure 16: Installing Two Screws.....	33
Figure 17: Installing the Mount Bracket On the Screws.....	34
Figure 18: Pre-Drill Holes on Mounting Bracket.....	34
Figure 19: Securing the Mount Bracket.....	35
Figure 20: Connecting an Ethernet Cable to PoE LAN port.....	36
Figure 21: Connecting an AC Power Adapter to the Access Point.....	38
Figure 22: Installing the Access Point on the Mounting Bracket.....	39
Figure 23: Seating the Access Point on the Mounting Bracket.....	40
Figure 24: Tightening the Mounting Bracket Thumbscrew.....	40
Figure 25: Fitting the Cables in the Cable Hide.....	41
Figure 26: Kensington Lock Port Location.....	42
Figure 27: TQ7613-R Login Prompt.....	43
Figure 28: User Exec Mode Prompt.....	46
Figure 29: Dimensions.....	47
Figure 30: Pin Layout for RJ45 Connector on LAN Ports.....	50
Figure 31: Antenna Locations and Axes.....	56

# Tables

---

Table 1. LED Status Information .....	20
Table 2. Shipping Box Components .....	24
Table 3. Physical Specifications .....	47
Table 4. Environmental Specifications .....	48
Table 5. External AC/DC Adapter Specifications .....	48
Table 6. PoE++ Power Specifications on LAN Ports .....	49
Table 7. LAN Port Specifications .....	50
Table 8. Pin Signals for 100M/1G/2.5G/5G/10G Base-T Connectors .....	50

# Preface

---

This guide contains the hardware installation instructions for the TQ7613-R access point.

This preface contains the following sections:

- ❑ “Safety Symbols Used in this Document” on page 8
- ❑ “Translated Safety Statements” on page 9
- ❑ “Contacting Allied Telesis” on page 10

## Safety Symbols Used in this Document

---

This document uses the following conventions.

---

**Note**

Notes provide additional information.

---



---

**Caution**

Cautions inform you that performing or omitting a specific action may result in equipment damage or loss of data.

---



---

**Warning**

Warnings inform you that performing or omitting a specific action may result in bodily injury.

---

Warnings inform you of hot surfaces.

---

## Translated Safety Statements

---

**Important:** The  indicates that a translation of the safety statement is available in a PDF document titled *Translated Safety Statements* on the Allied Telesis website at [www.alliedtelesis.com/library](http://www.alliedtelesis.com/library).

## **Contacting Allied Telesis**

---

If you need Allied Telesis technical support, visit  
**[www.alliedtelesis.com/support](http://www.alliedtelesis.com/support)**.

## Chapter 1

# Product Description

---

The sections in this chapter describe the hardware components of the TQ7613-R access point:

- “Hardware Components” on page 12
- “PoE LAN Ports” on page 16
- “LEDs” on page 20

## Hardware Components

---

The top view of the TQ7613-R access point is illustrated in Figure 1.

Back Edge



Front Edge

Figure 1. Access Point Top View

The bottom view is illustrated in Figure 2.

Back Edge

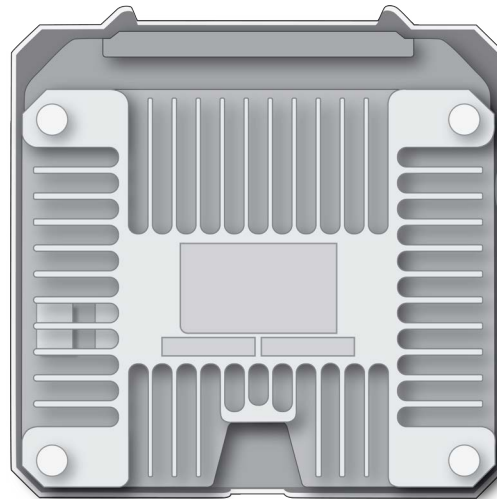

Front Edge

Figure 2. Access Point Bottom View

The front edge view is illustrated in Figure 3.

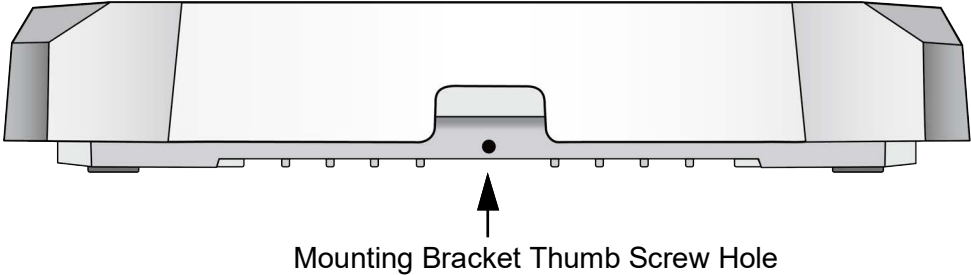

Figure 3. Front Edge View

The back edge view is illustrated in Figure 4.

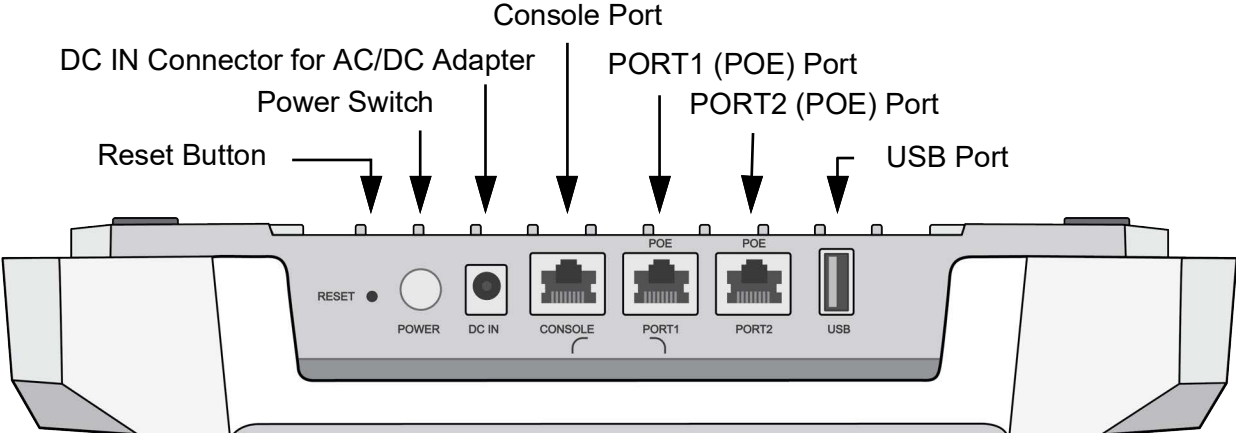

Figure 4. Back Edge View

The left edge view is illustrated in Figure 5.

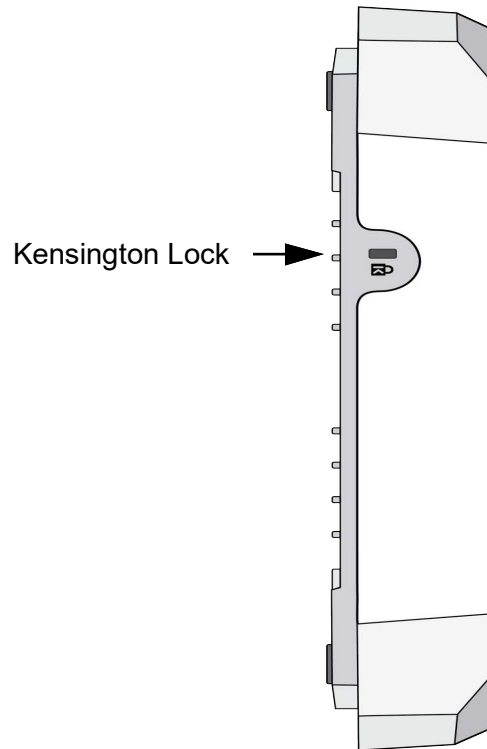

Figure 5. Left Edge View

**Antennas** The access point has the following embedded antenna:

- four 2.4G/5G dual band antenna
- four 6GHz single antenna
- one Bluetooth<sup>®</sup> Low Energy antenna

**Cable Hide** The top cover of the access point is larger than the access point chassis to create space on the back for cable connectors and cables shown in Figure 2 on page 12.

**Console Port** The Console Serial port on the back panel is for RS-232 communication.

**Power Switch** The Power Switch on the back panel in Figure 4 on page 13 turns ON or OFF the access point when power is supplied to the access point only from the AC adapter, not from the PORT1 (POE) or PORT2 (POE) ports.

When power is supplied to the access point from either of the POE ports, the state of the Power Switch does not affect the access point.

**USB Port** The USB port (USB2.0 Type A) can be used for storing configuration and log files and updating firmware.

**Kensington Lock  
Hole**

The left panel has a hole for the Kensington lock to be connected to an anti-theft cable/lock to physically secure the access point as shown in Figure 5 on page 14.

**Reset Button**

The access point has a Reset button on the back edge for returning the settings of the device to their default values. See Figure 4 on page 13. You might reset the access point if you want to discard its current configuration or if you forgot the manager password and so cannot manage the device.

To reset the device, press the button for five seconds and release.

You can enable or disable the reset button with the management software. The default setting for the button is enabled. If the access point is installed in a public area, you probably should disable it to protect the device from being reset by unauthorized individuals.

## PoE LAN Ports

The wireless access point has two Ethernet ports, labeled:

- ❑ PORT1 (POE)
- ❑ PORT2 (POE)

You use these ports to connect the wireless access point to your wired network. Here are their basic properties:

- ❑ Support PoE.
- ❑ The default setting for PORT1 is enabled. You cannot disable it.
- ❑ The default setting for PORT2 is disabled.
- ❑ PORT1 and PORT2 can be combined into a static Link Aggregation (LAG) to double the bandwidth between the wireless access point and the wired network.
- ❑ PORT2 can be configured as a separate Ethernet port for another network device. This is referred to as the Cascade mode.

### Static Link Aggregation

You can double the bandwidth between the wireless access point and your wired network by combining PORT1 and PORT2 ports into a static LAG. A static LAG functions as a single logical link between the wireless access point and another network device, such as an Ethernet switch or router. A static LAG also provides link redundancy. If one link goes down, the wireless access point maintains connectivity to the wired network over the remaining link. Refer to Figure 6.

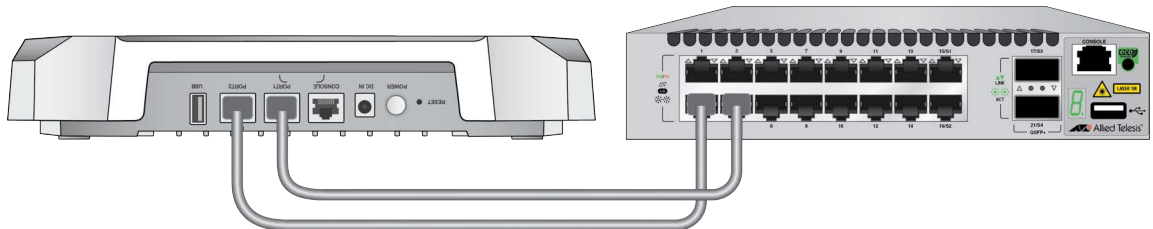

Figure 6. PORT1 and PORT2 Ports in a Static LAG

Here are guidelines to using PORT1 and PORT2 ports as a static LAG:

- ❑ You have to connect the ports to the same network device, such as an Ethernet switch or router, or virtual stacking devices. Do not connect the LAN ports to different network devices.
- ❑ The network device has to support Static LAGs.
- ❑ You have to configure the two ports on the network device as a static LAG.
- ❑ You activate the static LAG for PORT1 and PORT2 ports with the on-board web browser management interface.

**Note**

Do not enable and cable the PORT2 port until after you have configured the other network device for the static LAG.

**Cascade Mode** The PORT2 port also has a Cascade mode. The mode allows you to use the port to connect another device to your network. The device can be an end node such as a printer or computer, as shown in Figure 7.

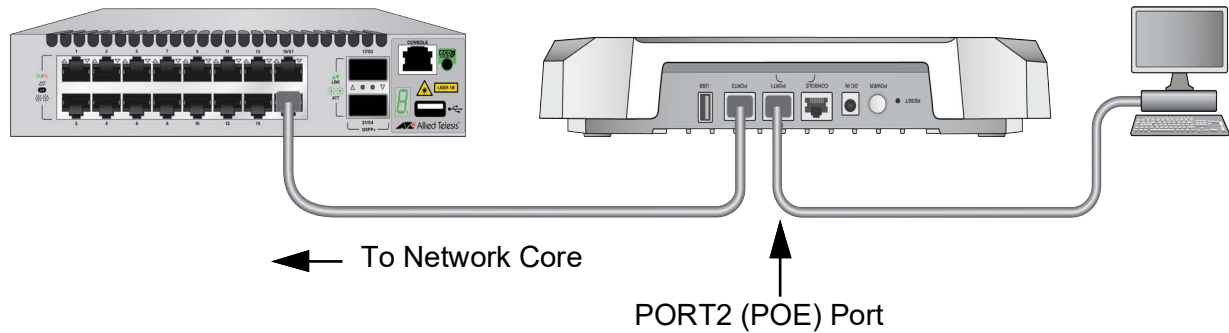

Figure 7. PORT2 Port in Cascade Mode with an End Node

It can also be a networking device such as a switch, router, or media converter. Refer to Figure 8.

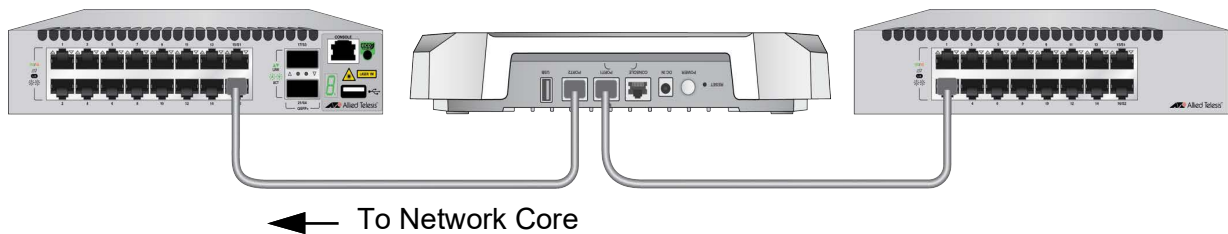

Figure 8. PORT2 Port in Cascade Mode with a Networking Device

Here are the Cascade mode guidelines:

- You set the Cascade mode with the on-board web browser management interface.
- The Cascade mode is not supported with Vista Manager EX and the AWC plug-in.
- Do not connect both PORT1 and PORT2 ports to the same network device when the PORT2 port is in the Cascade mode.

## **Power Over Ethernet Plus (PoE++)**

You can power the wireless access point with PoE++ on either Ethernet port, or with an AC/DC power adapter. The wireless access point is a PoE++ Class 6 powered device, with maximum power consumption (with IEEE802.3bt) of 51W.

To power the device with PoE+, you have to connect PORT1 or PORT2 to PoE power sourcing equipment (PSE). The network cable(s) connecting PORT1 and PORT2 to the PoE PSE carries both network traffic and PoE++.

You can power the device with both PoE++ and an AC/DC power adapter. However, the two power sources are not load sharing. The power adapter is the primary power source and PoE++ is redundant power.

## **Connector Type**

The LAN ports PORT1 and PORT2 have eight-pin RJ45 connectors. The ports use four pins of the connector at 100 Mbps and all eight pins at 1G/2.5G/10Gbps. Refer to the tables in “Port Pinouts” on page 50 for the pin assignments.

## **Speed**

Ports PORT1 and PORT2 have speeds of 100Mbps/1G/2.5G/5G/10Gbps. The speeds are set automatically with Auto-Negotiation. You cannot disable Auto-Negotiation on the ports.

---

### **Note**

The POE LAN ports should be connected to network devices that also adjust port speeds with Auto-Negotiation. If a network device does not support Auto-Negotiation, the LAN ports operate at 100 Mbps, which may reduce network performance.

---

## **Duplex Mode**

Ports PORT1 and PORT2 can operate in either half- or full-duplex mode at 100Mbps, and full-duplex mode at 1G/2.5G/5G/10Gbps. The ports are IEEE802.3u compliant and use Auto-Negotiation to set the duplex mode. You cannot disable Auto-Negotiation on the ports.

---

### **Note**

The network device to which you connect the POE LAN ports should also set the duplex mode with Auto-Negotiation. If a network device does not support Auto-Negotiation, the LAN ports operate at half-duplex mode. This may result in a duplex mode mismatch if the network device is operating at full duplex.

---

## **Automatic MDIX Detection**

When operating at 100Mbps, the twisted-pair ports feature automatic MDIX detection. (Automatic MDIX detection does not apply to 1G/2.5Gbps). This feature automatically configures the ports to MDI or MDI-X depending on the wiring configuration of the port on the Ethernet switch.

You cannot disable automatic MDIX detection. For automatic MDIX detection to work properly, this feature must also be present on the Ethernet switch. The LAN ports default to MDIX if connected to a network device that does not support automatic MDIX detection.

## **Cable Requirements**

The minimum cable requirements for the ports are listed here.

- 100Mbps port: Standard TIA/EIA 568-B-compliant Category 3 shielded or unshielded cabling.
- 1/2.5G/5G port: Standard TIA/EIA 568-A-compliant Category 5 or TIA/EIA 568-B-compliant Enhanced Category 5 (Cat 5e) unshielded cabling.
- 10Gbps port: Standard TIA/EIA 568-C-compliant Category 6a (Cat 6a) unshielded cabling.

## **Maximum Distance**

The LAN ports have a maximum operating distance of 100 meters (328 feet).

## **Port Pinouts**

See Table 8 on page 50 for port pinouts information.

## **Guidelines**

Here are the guidelines for using PORT1 and PORT2:

- Either port can be used to connect to your network.
- The default setting is enabled. You cannot disable them.

## LEDs

The LEDs on the top panel display status information. See Figure 9 for LEDs and Table 1 for the status definition.

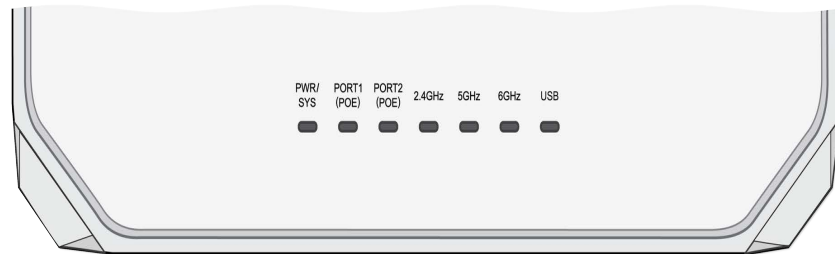

Figure 9. Top View - LEDs

Table 1. LED Status Information

LED	State	TQ7613-R
PWR/ SYS	Green	The access point is powered ON and operating normally
	Red	The access point is booting up
	Off	The access point is not receiving power
PORT1 (POE)	Green	The port has established a link to a network device
	Blinking Green	The port is transmitting or receiving data
	Off	The port has not established a link to a network device
PORT2 (POE)	Green	The port has established a link to a network device
	Blinking Green	The port is transmitting or receiving data
	Off	The port has not established a link to a network device
2.4GHz	Green	The 2.4GHz radio is enabled
	Off	The 2.4GHz radio is disabled
5GHz	Green	The 5GHz radio is enabled
	Off	The 5GHz radio is disabled
6GHz	Green	The 6GHz radio is enabled
	Off	The 6GHz radio is disabled
USB	Green	A USB device is plugged in
	Blinking Green	Data is being read or written to the USB device
	Off	The USB feature is disabled in the GUI

## Chapter 2

# Installing the Wireless Access Point

---

This chapter contains the installation procedures for the TQ7613-R Access Point. The procedures are detailed in the following sections:

- ❑ “Reviewing Safety Precautions” on page 22
- ❑ “Unpacking the Shipping Box” on page 24
- ❑ “Reviewing Installation Guidelines” on page 25
- ❑ “Allied OneConnect Onboarding Service” on page 27
- ❑ “Installing the Access Point on a Table” on page 28
- ❑ “Overview to Installing the Access Point on a Wall or Ceiling” on page 29
- ❑ “Pre-fitting the Mounting Bracket on the Access Point” on page 30
- ❑ “Installing the Mounting Bracket on a Wall or Ceiling” on page 32
- ❑ “Connecting Ethernet Cables to the LAN Ports” on page 36
- ❑ “Connecting the AC Power Adapter” on page 38
- ❑ “Attaching the Access Point to the Mounting Bracket” on page 39
- ❑ “Installing an Anti-theft Device” on page 42
- ❑ “Starting the First Management Session” on page 43

---

### Note

The non-US models of this product have a country code setting that must be set during the initial management session of the units. The setting ensures that the units operate in compliance with the laws and regulations of your country or region.

For the US model, the country code is preset and cannot be changed. Per FCC regulations, the country code setting for all WiFi products marketed in the US must be fixed to US operational channels only.

---

## Reviewing Safety Precautions

---

Review the following safety precautions before installing the access point.

**Important:** Safety statements that have the ⚡ symbol are translated into multiple languages in the *Translated Safety Statements* document, which is available at [www.alliedtelesis.com/library](http://www.alliedtelesis.com/library).

**Warning**

To prevent electric shock, do not remove the cover. No user-serviceable parts inside. This unit contains hazardous voltages and should only be opened by a trained and qualified technician. To avoid the possibility of electric shock, disconnect electric power to the product before connecting or disconnecting the LAN cables.

⚡ E1

---

**Warning**

Do not work on equipment or cables during periods of lightning activity. ⚡ E2

---

**Warning**

All Countries: Install product in accordance with local and National Electrical Codes. ⚡ E8

---

**Warning**

Only trained and qualified personnel are allowed to install or to replace this equipment. ⚡ E14

---

**Warning**

To reduce the risk of electric shock, the PoE ports on this product must not connect to cabling that is routed outside the building where this device is located. ⚡ E40

---

**Warning**

This equipment shall be installed in a Restricted Access location. ⚡ E45

---

**Caution**

Air vents must not be blocked and must have free access to the room ambient air for cooling. ⚡ E6

---

An operational unit can be hot. Exercise caution when handling with unprotected hands.

---

**Warning**

Operating Temperature. This product is designed for a maximum ambient temperature of 50°C (122° F) ⚡ E7.

---

**Warning**

To reduce the risk of electric shock, the PoE port on this product must not connect to cabling that is routed outside the building where this device is located. ⚡ E40

---

**Warning**

This equipment is intended for indoor use only. ⚡ E95

---

**Note**

If you are not using PoE to power to unit, use only an approved AC/DC adapter. Refer to “Power Specifications” on page 48.

---

**Caution**

The unit does not contain serviceable components. Please return damaged units for servicing. ⚡ E42

---

**Note**

You should verify that your PoE network adheres to the standards of a separated extra-low voltage (SELV) circuit before using the PoE feature on the wireless access point.

---

## Unpacking the Shipping Box

To verify the contents of the shipping box, perform the following procedure:

1. Remove all components from the shipping box.

---



### Note

Store the packaging material in a safe location. Use the original shipping material if you need to return the device to Allied Telesis.

---

2. Verify the contents of the shipping box listed in Table 2. If any item is missing or damaged, contact your Allied Telesis sales representative for assistance.

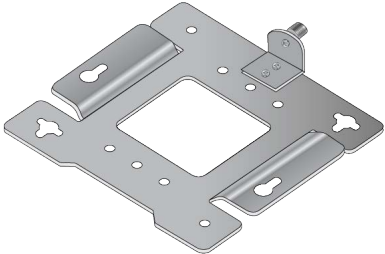
Table 2. Shipping Box Components

Name	Component
TQ7613-R Access Point	
One Mounting Bracket	
Two M5 x 4.5 mm, Pan-head Screws	

## Reviewing Installation Guidelines

---

Review the following guidelines before installing the access point:

- ❑ The ceiling or wall mounting surface must be of proper material to accommodate the screws and strong enough to support the weight of the access point and cables. (Refer to Table 3 on page 47 for the product weight.)
- ❑ You can install the access point on a wall where Cisco or Fortinet bracket has already been installed. You need a bracket converter. See “the *BRKT-CONV-AP1 Bracket Converter Installation Guide*” on [www.alliedtelesis.com/library](http://www.alliedtelesis.com/library) for more information.
- ❑ Connect the Ethernet cable(s) and power cord (if applicable) to the access point before installing the product on the ceiling or wall. Depending on the installation location, connecting or removing cables may be difficult after the device is installed.
- ❑ Verify that the Ethernet cable(s) is long enough to connect to its destination port(s) before installing the access point. Once the installation is complete, it is physically difficult to change the cables.
- ❑ If the wireless access point is powered by an AC adapter, verify that an AC power outlet is within six feet of the planned installation site. (Refer to “Power Specifications” on page 48 for the AC adapter specifications.)
- ❑ On a wall, the access point must be installed horizontally or vertically.
- ❑ Refer to Figure 10 on page 26 for approved and unapproved orientations of the wireless access point on a table, wall, or ceiling.

Ceiling Installation

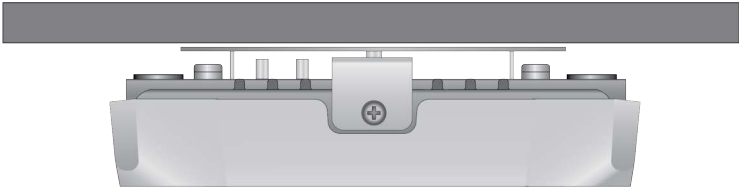

Wall Installation

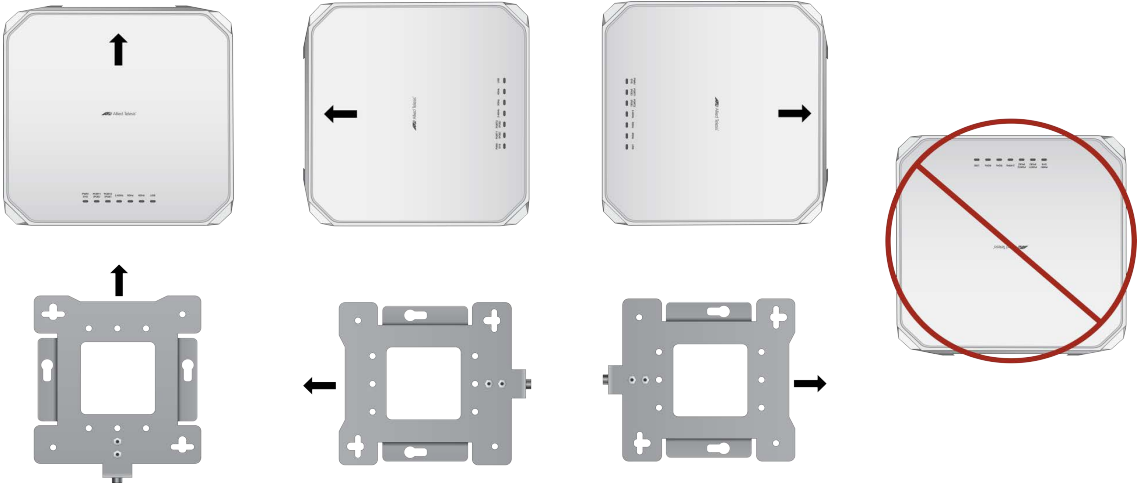

Table Installation

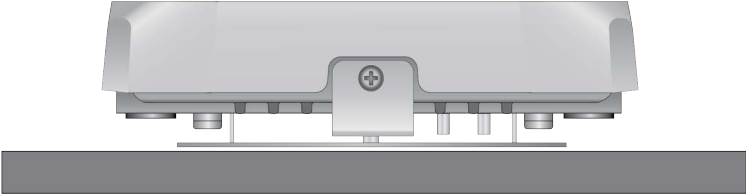

Figure 10. Approved and Unapproved Orientations on a Ceiling, Wall, or Table

## Allied OneConnect Onboarding Service

---

The AT-TQ7613-R model is part of the TQR Series.

The TQR Series features the OneConnect Onboarding service from Allied Telesis. The service automatically configures managed Allied Telesis products by downloading customized configuration packages from a regional cloud-based OneConnect Onboarding server.

**Please read the following before powering on the device:**

- ❑ The access point automatically starts the OneConnect Onboarding service when it receives an IPv4 address from a DHCP server. The port and system LEDs will begin flashing after connecting with the cloud-based service and starting the download process.
- ❑ The access point automatically disables the OneConnect Onboarding service if it is not registered with the service.
- ❑ OneConnect Onboarding uses SZTP, NTP, DHCP, and DNS to contact its cloud-based server.

For information on Allied OneConnect Onboarding, consult your Allied Telesis Partner or refer to the *Allied OneConnect Onboarding Installation Guide* on the Allied Telesis web site at [www.alliedtelesis.com/library](http://www.alliedtelesis.com/library).

## Installing the Access Point on a Table

---

You need the following items to install the access point on a table:

- TQ7613-R Access Point
- Ethernet cable(s)
- External AC power adapter (Optional if using PoE++. Required if not using PoE++ or for redundant power.)
- Kensington lock (optional)

---

**Note**

See “Reviewing Safety Precautions” on page 22 and “Reviewing Installation Guidelines” on page 25 before installing the product.

---

Perform the following steps to install the wireless access point on a table:

1. Place the access point at the selected location on the table.
2. Connect an Ethernet cable to PORT1 (POE).  
  
See “Connecting Ethernet Cables to the LAN Ports” on page 36.
3. To connect an AC power adapter to the access point, go to “Connecting the AC Power Adapter” on page 38.
4. To install a security cable, refer to “Installing an Anti-theft Device” on page 42.
5. To start managing the device, go to “Starting the First Management Session” on page 43.

## Overview to Installing the Access Point on a Wall or Ceiling

---

Here are the procedures for installing the wireless access point on a wall or ceiling:

- ❑ “Pre-fitting the Mounting Bracket on the Access Point” on page 30
- ❑ “Installing the Mounting Bracket on a Wall or Ceiling” on page 32
- ❑ “Connecting Ethernet Cables to the LAN Ports” on page 36
- ❑ “Connecting the AC Power Adapter” on page 38
- ❑ “Attaching the Access Point to the Mounting Bracket” on page 39
- ❑ “Installing an Anti-theft Device” on page 42

---

**Note**

See “Reviewing Safety Precautions” on page 22 and “Reviewing Installation Guidelines” on page 25 before installing the product.

---

---

**Note**

Depending on the installation location, it may be easier to connect the network cables and optional power adapter to the wireless access point before installing it on the wall or ceiling.

---

You need the following items to install the wireless access point on a ceiling or wall:

- ❑ TQ7613-R Access Point
- ❑ Two screws to attach the access point to the mounting bracket
- ❑ Mounting bracket
- ❑ Four M4x25mm flat-head wood screws and anchors (not provided) for fastening the mounting bracket
- ❑ Phillips head screwdriver (not provided)
- ❑ Pencil (not provided)
- ❑ External AC power adapter (Optional if using PoE++. Required if not using PoE++ or for redundant power.)
- ❑ Kensington lock (optional and not provided)

---

**Note**

The four Phillips head M4 screws/anchors, the Phillips head screwdriver, pencil, external AC power adapter and Kensington lock are *not* included with the product.

---

## Pre-fitting the Mounting Bracket on the Access Point

To pre-fit the mounting bracket on the access point, perform the following procedure:

1. Place the wireless access point upside down on a stable flat surface.
2. Install the two screws (provided) fully into the bottom panel of the access point. See Figure 11.

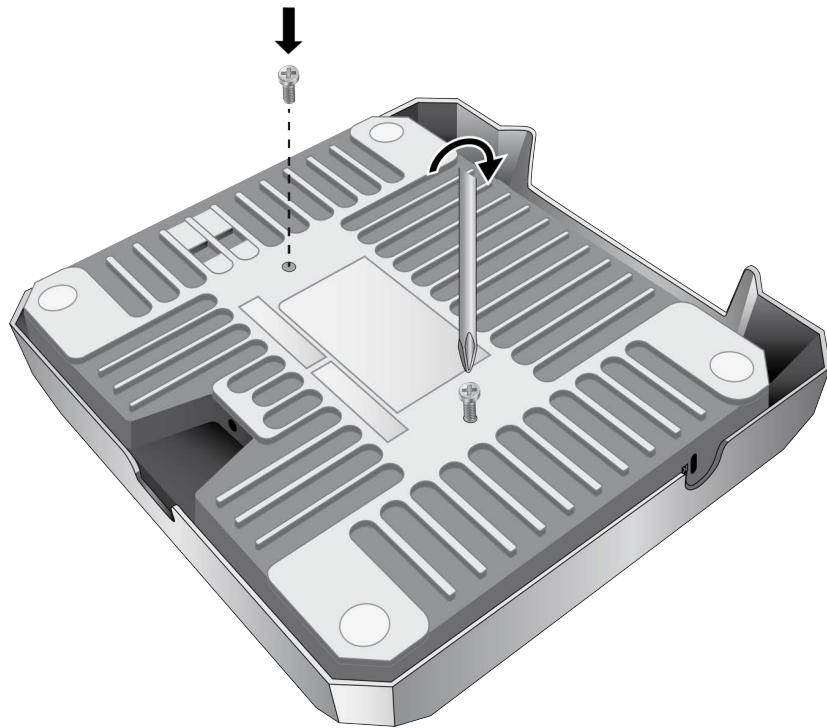

Figure 11. Attaching the Bracket Screws to the Access Point

The screw collar provides the proper spacing for the mounting bracket beneath the screw head. See Figure 12 on page 30.



Figure 12. Panel Screw

3. Make sure that the mounting bracket fits to the access point by sliding the bracket beneath the screws as shown in Figure 13.

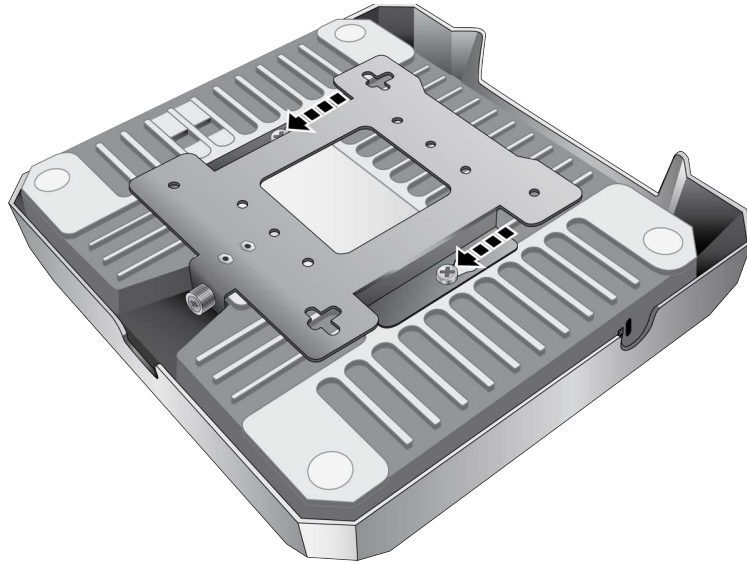

Figure 13. Attaching the Mounting Bracket on the Access Point

4. Slide the mounting bracket forward and remove it from the access point. See Figure 14.

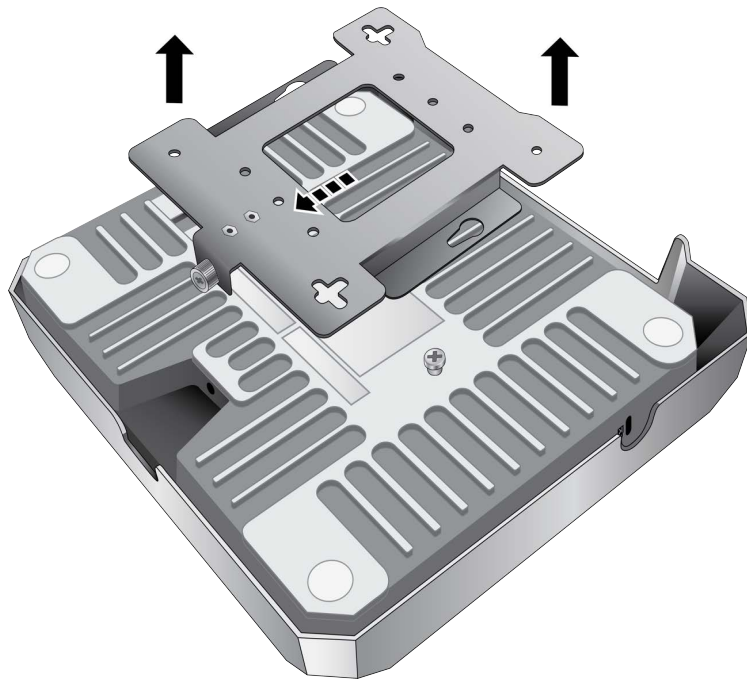

Figure 14. Removing the Mounting Bracket from the Access Point

5. Go to “Installing the Mounting Bracket on a Wall or Ceiling” on page 32.

## Installing the Mounting Bracket on a Wall or Ceiling

---

To install the mounting bracket on a wall or ceiling, perform the following procedure:

1. Choose the location and orientation for the access point on the wall or ceiling. Refer to Figure 10 on page 26.
2. Position the mounting bracket at the selected location and orientation for the access point. Consider the following guidelines.
  - ❑ The thumbscrew on the mounting bracket is where the front panel of the access point will be.
  - ❑ The ports and connectors are on the back panel, away from the thumbscrew.
3. With a pencil, mark the wall or ceiling with the two keyhole slots of the bracket. Refer to Figure 15.

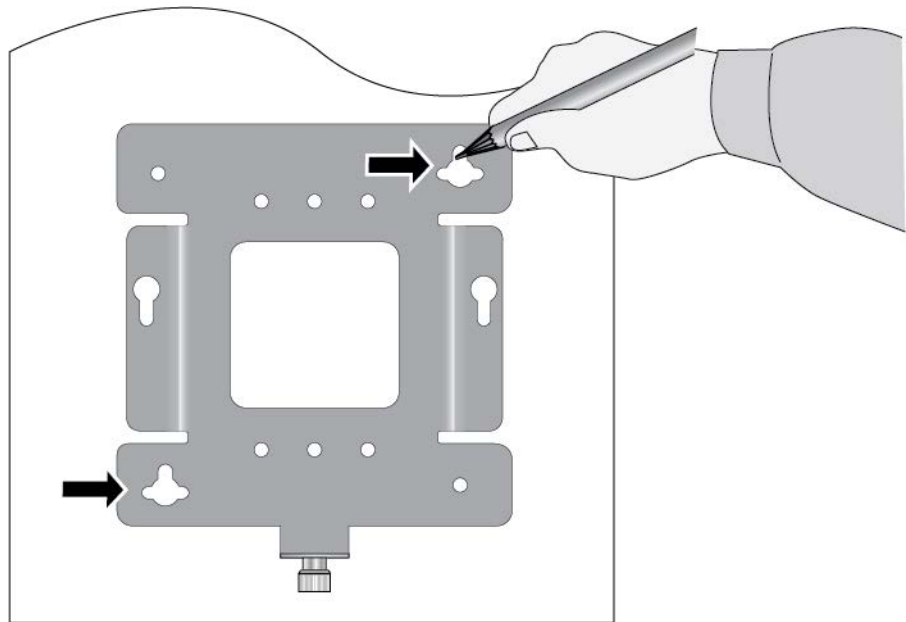

Figure 15. Marking the Holes for the Keyhole Slots

4. Pre-drill the two marked locations for the keyhole slots on the hard-surface ceiling or wall.

5. Install two M4 screws and anchors (if required). Leave the screws loose enough so that the bracket can slide under the screw heads. Refer to Figure 16.

---

**Note**

For a wooden wall or ceiling, use M4 x 25 mm flat-head wood screws and anchors, if required. The screws and anchors are not provided.

---

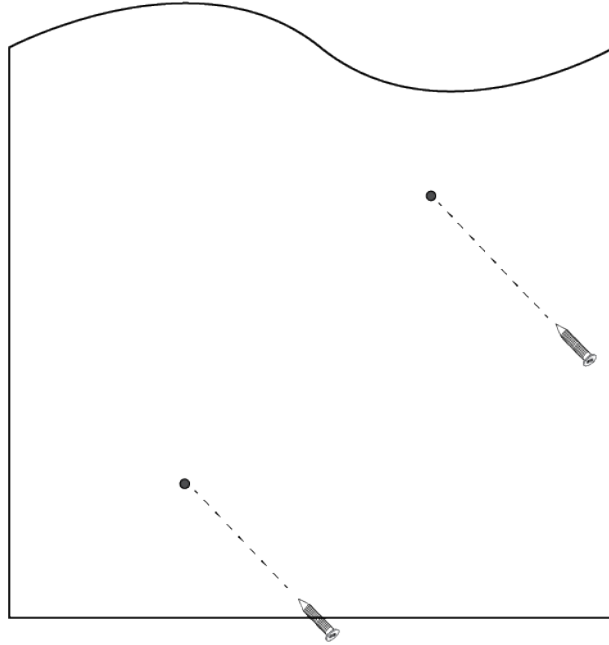

Figure 16. Installing Two Screws

6. Insert the openings of the bracket keyhole slots under the two screw heads and slide the bracket into the narrow end of the keyhole slot openings. See Figure 17.

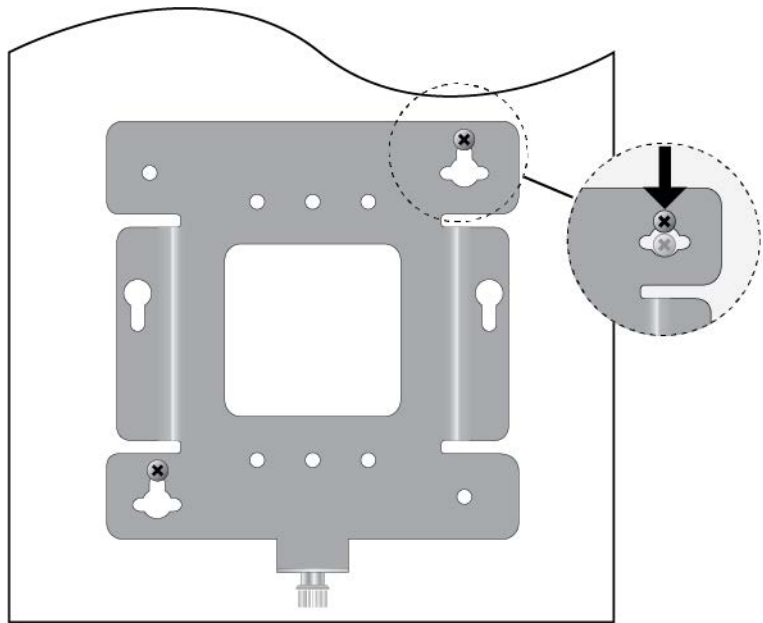

Figure 17. Installing the Mount Bracket On the Screws

7. Tighten the screws snugly onto the bracket.
8. To secure the mounting bracket, pre-drill holes through the two bracket mounting holes opposite the keyhole slots. See Figure 18.

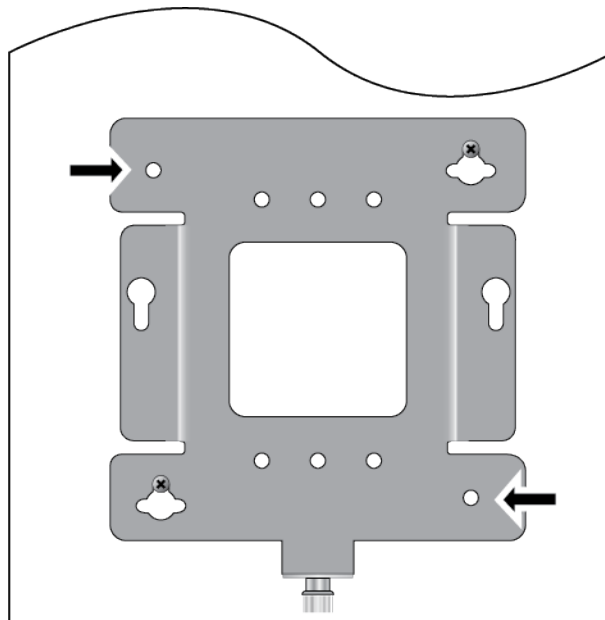

Figure 18. Pre-Drill Holes on Mounting Bracket

9. Install and tighten two M4 screws (not provided) in the holes prepared in Step 8.

The bracket installation is now complete. See Figure 19.

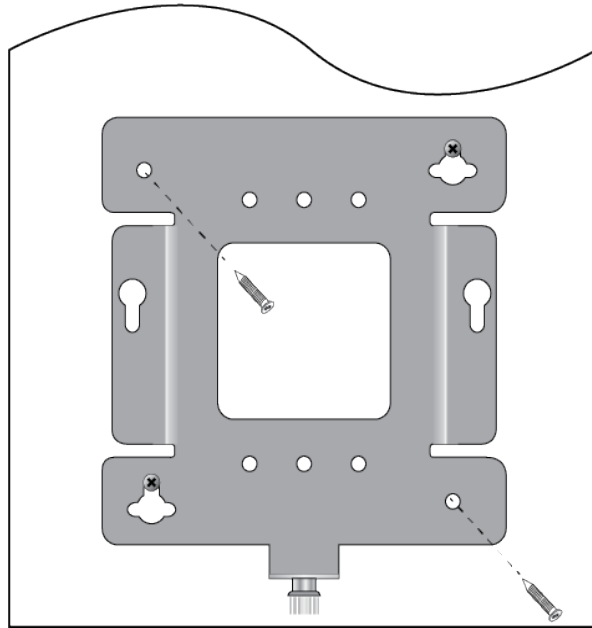

Figure 19. Securing the Mount Bracket

10. Go to “Connecting Ethernet Cables to the LAN Ports” on page 36.

## Connecting Ethernet Cables to the LAN Ports

This section describes the instructions for connecting Ethernet cables to the PoE LAN ports, PORT1 (POE) and PORT2 (POE).

**Guidelines** Review the following guidelines before connecting cables to the PoE LAN ports:

- ❑ For information on cable specifications, see “Cable Requirements” on page 19.
- ❑ If you are installing the access point on a ceiling or wall, you might find it easier to connect the cables before placing the unit on the mounting bracket.
- ❑ Use either PoE LAN port to connect the access point to the network.
- ❑ To power the access point through the PoE++ LAN port, see “PoE++ Power Requirements” on page 49.
- ❑ The default setting for both PoE LAN ports on the wireless access point is disabled. You enable it with the on-board web browser management interface. For instructions, see the *TQ7613-R Management Software User’s Guide*.

### Connecting Ethernet Cables to the LAN Ports

To connect the network cable, perform the following procedure:

1. Connect an Ethernet cable into either PoE LAN port. The cable requirements are in “Cable Requirements” on page 19. Refer to Figure 20.

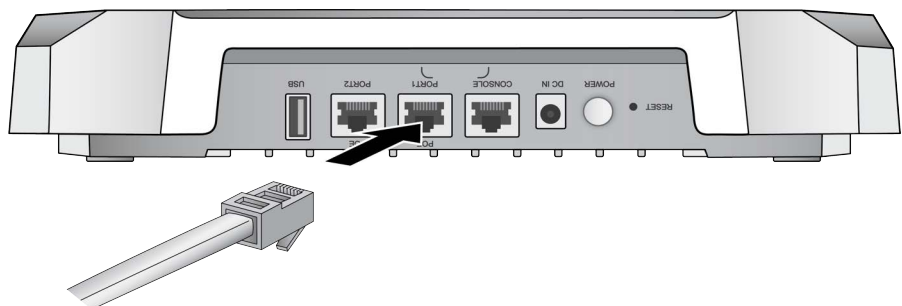

Figure 20. Connecting an Ethernet Cable to PoE LAN port

2. Connect the other end of the Ethernet cable to a network Ethernet device, such as an Ethernet switch or router.

---

**Note**

If the device is PoE++ power sourcing equipment (PSE), the access point begins to power on and initialize its management software.

---

3. Do one of the following:
  - a. If the access point is to be powered only by PoE++, without an AC power adapter, go to “Attaching the Access Point to the Mounting Bracket” on page 39.
  - b. To connect an external AC power adapter, go to “Connecting the AC Power Adapter”.

## Connecting the AC Power Adapter

---

The access point can be powered with PoE++ on either of the PoE LAN ports, an AC power adapter, or both. A wireless access point that is powered by both methods uses the AC adapter as its primary power and PoE as redundant power. For an AC power adapter, Allied Telesis recommends the PWRADP-01 (DA-48Z12) Power Adapter.

If you purchased a power adapter for the wireless access point, perform the following procedure. Otherwise, go to “Attaching the Access Point to the Mounting Bracket” on page 39.

Perform the following procedure to install an AC power adapter:

1. If the AC power adapter has replaceable AC plugs, verify that the current plug on the adapter is the correct plug for your region. If it is not, install the correct AC plug by following the instructions provided with the adapter.
2. Plug the DC connector of the power adapter into the DC IN jack on the access point. Refer to Figure 21.

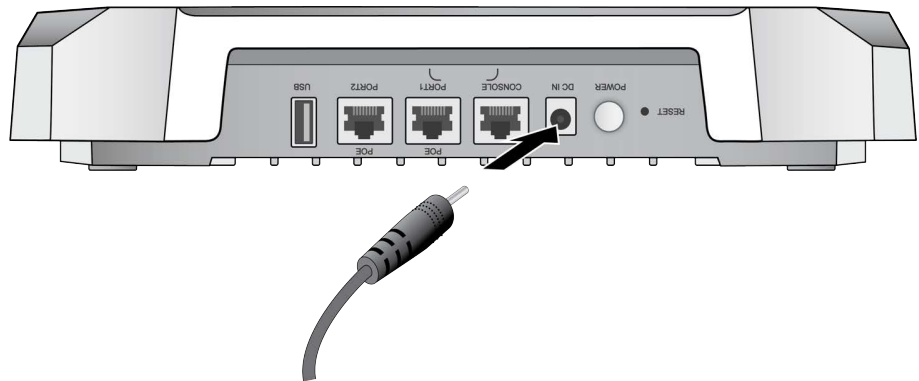

Figure 21. Connecting an AC Power Adapter to the Access Point

3. Connect the power adapter to an appropriate AC power source.
4. Turn on the Power Switch.

---

**Note**

The Power Switch controls power from the AC power supply. It does not control PoE++ on the PoE LAN ports.

---

5. Go to “Attaching the Access Point to the Mounting Bracket” on page 39.

## Attaching the Access Point to the Mounting Bracket

---

To attach the wireless access point on the mounting bracket on the wall or ceiling, perform the following procedure:

1. Align the bottom of the access point over the bracket so that the two screws on the bottom of the device fit into the bracket keyholes. Refer to Figure 22. (These are the two access point chassis screws installed in “Pre-fitting the Mounting Bracket on the Access Point” on page 30.)

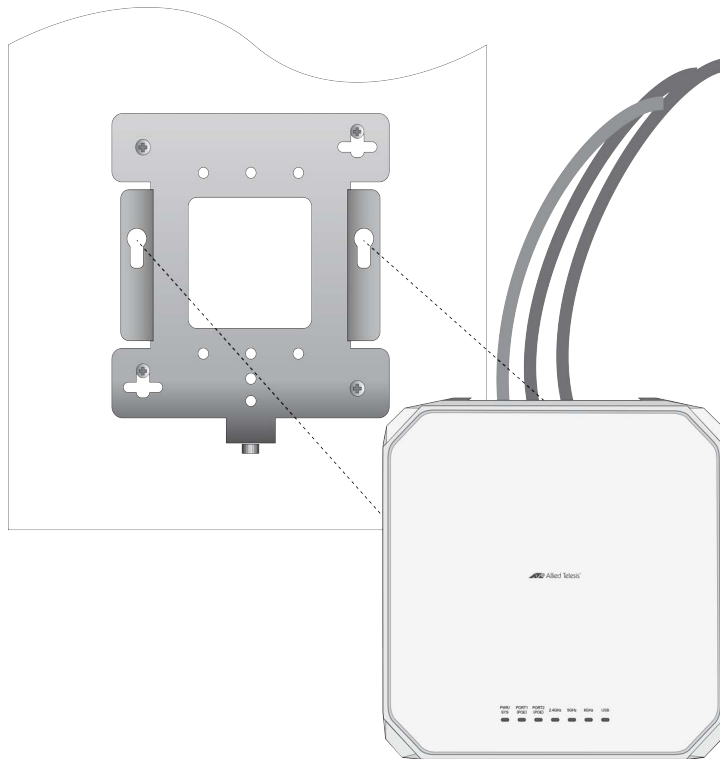

Figure 22. Installing the Access Point on the Mounting Bracket

2. Slide the access point forward until its screws are seated in the bracket keyhole slots and the bracket thumbscrew is aligned with the screw hole on the front panel.

See Figure 23 on page 40 for the access point and bracket orientations.

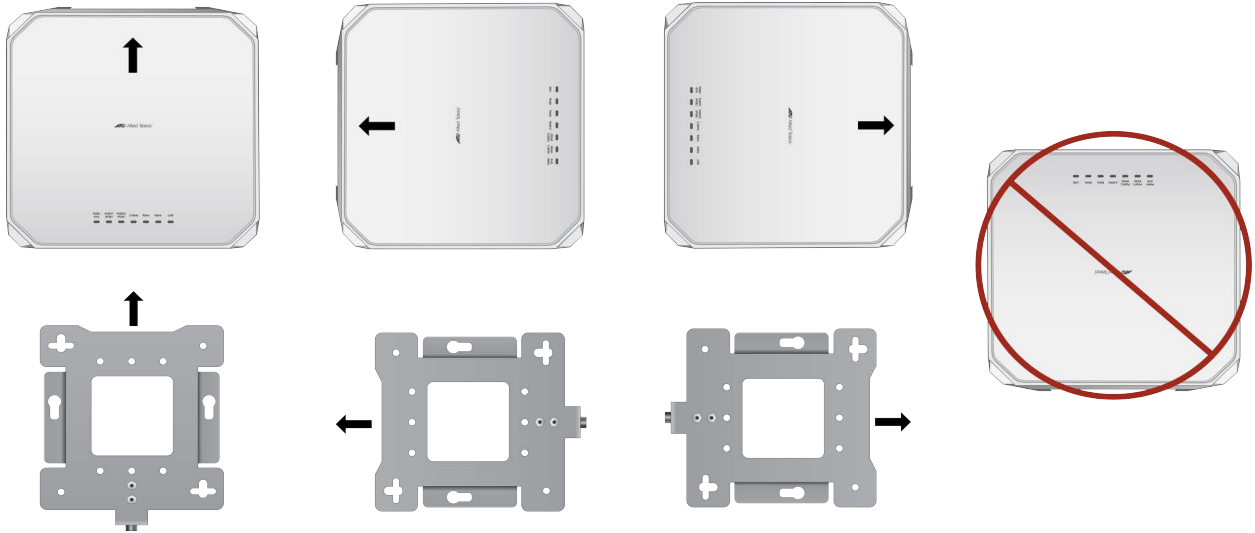

Figure 23. Seating the Access Point on the Mounting Bracket

3. Tighten the thumbscrew to secure the access point to the mounting bracket. Refer to Figure 24.

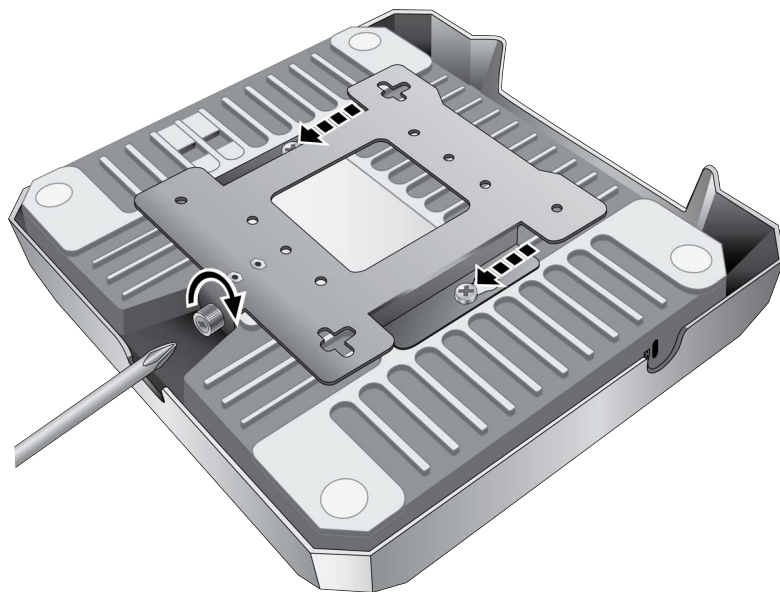

Figure 24. Tightening the Mounting Bracket Thumbscrew

4. Place the Ethernet cable(s) and power cable (if any) along the cable guides inside of the top cover in the cable hide space. See Figure 25.

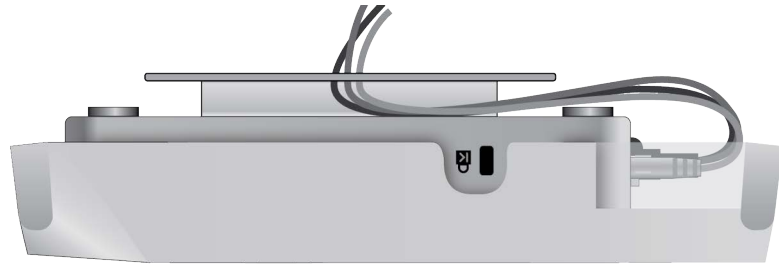

Figure 25. Fitting the Cables in the Cable Hide

5. If you install an anti-theft device, go to “Installing an Anti-theft Device” on page 42.
6. Go to “Starting the First Management Session” on page 43.

## Installing an Anti-theft Device

---

Installation of an anti-theft cable/lock is optional. The access point has a lock port that is compatible with a Kensington lock. The lock port can be used to physically secure the device to a table, wall, or a ceiling.

---

**Note**

Anti-theft devices are not available from Allied Telesis.

---

1. Follow the instructions provided with the vendor's anti-theft device for the installation. See Figure 26 for the Kensington lock port location.

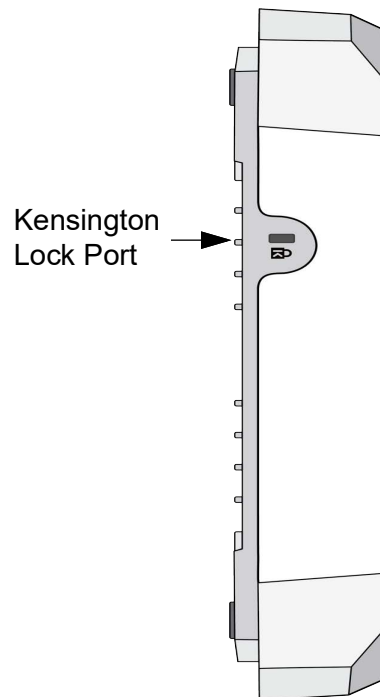

Figure 26. Kensington Lock Port Location

2. If you are installing the wireless access point on a wall or ceiling and have not installed in on the mounting bracket yet, go to “Attaching the Access Point to the Mounting Bracket” on page 39.

## Starting the First Management Session

---

This section contains an abbreviated version of the procedure to start the first management session. For complete instructions, refer to the TQ7613-R *Management Software User's Guide*.

---

### Note

You can access the TQ7613-R model using the Console port, in addition to using the Web User Interface. To start a management session via the Console port of the TQ7613-R model, see “Starting a Local Management Session” on page 45.

---

The wireless access point firmware includes a DHCP client. The default setting for the client is enabled. When you power on the access point for the first time, it queries the subnet on PORT1 (POE) for a DHCP server. If a DHCP server responds to its query, the unit uses the IP address the server assigns to it. If there is no DHCP server, the access point uses the default IP address 192.168.1.1.

To start the first management session, perform the following procedure:

1. Start the web browser on your management workstation.
2. Enter the IP address of the wireless access point in the URL field of the web browser. The address is one of the following:
  - If your network does not have a DHCP server, enter the default address 192.168.1.1.
  - If your network has a DHCP server, enter the IP address the DHCP server assigned to the access point.

The wireless access point displays the login prompt. See Figure 27.

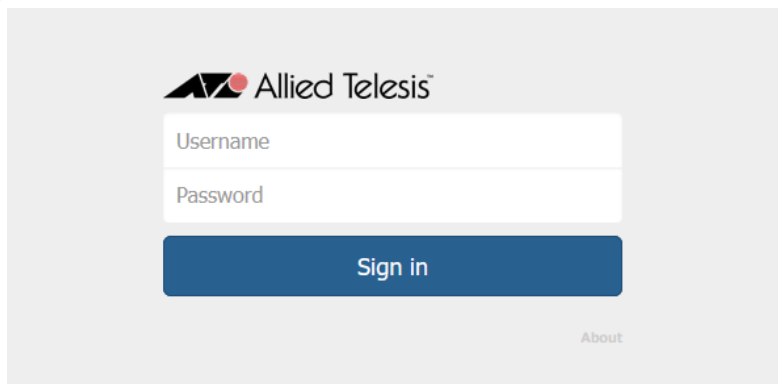

Figure 27. TQ7613-R Login Prompt

3. Enter the login information:

- Username: manager
- Password: friend

---

**Note**

The user name and password are case-sensitive.

---

4. Click the Sign in button.

The first management page appears.

## Starting a Local Management Session

---

This procedure explains how to start a local management session on the TQ7613-R device. It assumes that you powered on the device and waited about two minutes for it to initialize its operating software.

---

**Note**

A management session of the TQ7613-R device can be either a local session from the Console port, as explained in this section, or a session from the Web User Interface. For a session from the Web User Interface, see “Starting the First Management Session” on page 43.

---

To start a local management session, perform the following procedure:

1. Connect the RJ-45 end of the management cable to the Console port on the TQ7613-R device.
2. Connect the other end of the cable to an RS-232 port on a terminal or personal computer with a terminal emulation program.
3. Configure a terminal or terminal emulation program as follows:
  - Baud rate: 115200 bps
  - Data bits: 8
  - Parity: None
  - Stop bit: 1
  - Flow controller: None
  - Emulation: VT100

---

**Note**

The port settings are for a DEC VT100 or ANSI terminal, or an equivalent terminal emulator program.

---

4. Press Enter. You are prompted for a user name and password.
5. Enter the login information:
  - Username: manager
  - Password: friend

---

**Note**

User names and passwords are case sensitive.

---

The local management session starts when the User Exec mode prompt, shown in Figure 28, is displayed.

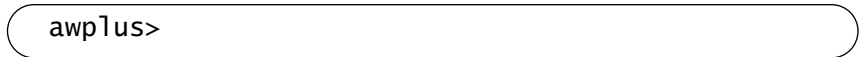
A rounded rectangular box containing the text "awp1us>".

```
awp1us>
```

Figure 28. User Exec Mode Prompt

---

**Note**

The AlliedWare™ Plus operating system is installed on the TQ7613-R device.

---

## Appendix A

# Technical Specifications

This appendix contains the specifications for the TQ7613-R access point in the following sections:

- “Physical Specifications”
- “Environmental Specifications” on page 48
- “Power Specifications” on page 48
- “Cable Specifications” on page 49
- “LAN Port Specifications and Pinouts” on page 50

## Physical Specifications

Table 3. Physical Specifications

Parameter	Specification
Dimensions (W x D x H)	265 mm X 265 mm X 45 mm (10.4 in. x 10.4 in. x 1.8 in.)
Weight	1.6kg (3.53 lbs)

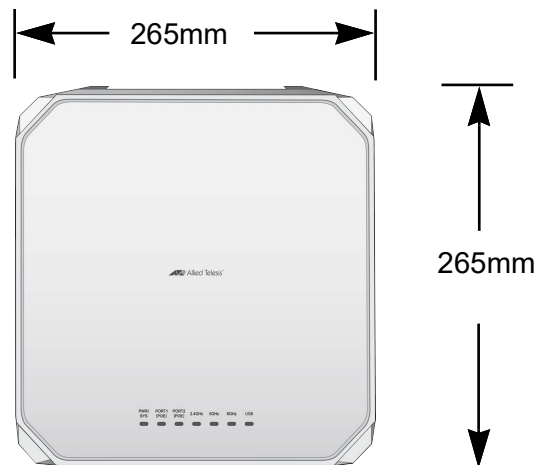

Figure 29. Dimensions

## Environmental Specifications

---

Table 4. Environmental Specifications

Parameter	Specification
Operating Temperature	0° C to 50° C (32° F to 122° F)
Storage Temperature	- 25° C to 70° C (- 13° F to 158° F)
Operating Humidity	5% to 90% non-condensing
Storage Humidity	0% to 95% non-condensing
Maximum Operating Altitude	3000 m (9843 ft)

## Power Specifications

---

### External AC Adapter Specifications

Table 5. External AC/DC Adapter Specifications

Parameter	Specification
Input Voltage Range	100 - 240 VAC
Input Frequency	47 - 63 Hz
Rated Output Voltage	+12 VDC
Rated Output Current	4 A
Temperature Range	0° C to 50° C (32° F to 122° F)
Maximum Operating Altitude	3000 m (9843 ft)

---

#### Note

If you decide to use an AC adapter with the access point, Allied Telesis recommends the PWRADP-01 (DA-48Z12) adapter. The adapter is a UL Listed power supply and is compatible with the above specifications while meeting the standards of a separated extra-low voltage (SELV) product.

---



---

#### Note

The PWRADP-01 (DA-48Z12) adapter is sold separately.

---

## PoE++ Power Requirements

Table 6. PoE++ Power Specifications on LAN Ports

<b>Maximum Power Consumption</b>	43.5 watts
<b>Rated Voltage</b>	54.5V
<b>Rated Current</b>	1.3A

---

**Note**

Allied Telesis recommends using UL-Certified LPS (Limited Power Source) PoE injectors.

---

## Cable Specifications

---

The minimum cable requirements for PORT (POE) are listed here.

- ❑ 100Mbps ports: Standard TIA/EIA 568-B-compliant Category 3 shielded or unshielded cabling.
- ❑ 1G/2.5G/5G/10G ports: Standard TIA/EIA 568-A-compliant Category 5 or TIA/EIA 568-B-compliant Enhanced Category 5 (Cat 5e) unshielded cabling.

---

**Note**

The maximum operating distance of the cables is 100 meters (328 feet).

---

## LAN Port Specifications and Pinouts

### Port Specifications

The access point port specifications are shown in Table 7.

Table 7. LAN Port Specifications

Connector	Specification
PoE standard : PORT 1 (POE) PORT 2 (POE)	IEEE 802.3bt (Class 6)

### Port Pinouts

The pin signal definitions for PORT1 (POE) & PORT2 (POE) are given here. Figure 30 illustrates the pin layout of the ports.

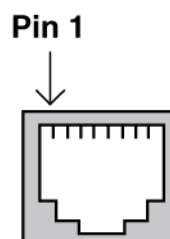

Figure 30. Pin Layout for RJ45 Connector on LAN Ports

Table 8 lists the pin signals.

Table 8. Pin Signals for 100M/1G/2.5G/5G/10G Base-T Connectors

Pin	100 Mbps MDI Signal	100 Mbps MDI-X Signal	1G/2.5G/5G/10G Signal
1	TX+	RX+	Bi-directional pair A+
2	TX-	RX-	Bi-directional pair A-
3	RX+	TX+	Bi-directional pair B+
4	Not used	Not used	Bi-directional pair C+
5	Not used	Not used	Bi-directional pair C-
6	RX-	TX-	Bi-directional pair B-
7	Not used	Not used	Bi-directional pair D+
8	Not used	Not used	Bi-directional pair D-

## Appendix B

# Regulatory Statements

---

This appendix contains the following regulatory statements:

- “European Union Restriction of the Use of Certain Hazardous Substances (RoHS) in Electrical and Electronic Equipment” on page 52
- “Europe - EU Declaration of Conformity” on page 53

## **European Union Restriction of the Use of Certain Hazardous Substances (RoHS) in Electrical and Electronic Equipment**

---

This Allied Telesis RoHS-compliant product conforms to the European Union Restriction of the Use of Certain Hazardous Substances (RoHS) in Electrical and Electronic Equipment. Allied Telesis ensures RoHS conformance by requiring supplier Declarations of Conformity, monitoring incoming materials, and maintaining manufacturing process controls.

---

### **Note**

For additional regulatory statements, refer to Appendix 4, "Regulatory Statements" on page 51.

---

## Europe - EU Declaration of Conformity

Hereby, Allied Telesis declares that the radio equipment type [AT-TQ7613-R] is in compliance with Directive 2014/53/EU.

### Operating Frequencies and Maximum Transmission Power Levels

The operating frequencies and maximum transmission power levels for wireless devices operated in the EU are listed below:

AT-TQ7613-R

	Beamforming	Non-Beamforming
2412-2472 MHz	19.96	19.94
2412-2472 MHz (BLE)	-	11.17
2412-2472 MHz (ZigBee)	-	12.56
5150-5250 MHz	22.82	22.88
5250-5350 MHz	22.84	22.95
5470-5725 MHz	29.97	29.96
5925-6425 MHz	22.94	22.96

#### Note

Operations in the 5.15 - 5.35GHz, and 5.925 - 6.425GHz band are restricted to indoor usage only.

### Radiation Exposure Statement

This equipment complies with CE radiation exposure limits set forth for an uncontrolled environment. This equipment should be installed and operated with a minimum distance of 20 cm between the radiator and your body.



AT	BE	BG	CH	CY	CZ	DE	DK	EE
EL	ES	FI	FR	HR	HU	IE	IS	IT
LI	LT	LU	LV	MT	NL	NO	PL	PT
RO	SE	SI	SK	TR	UK (NI)			

### Importer

Allied Telesis International BV  
Incheonweg 7, 1437 EK Rozenburg

---

**Note**

Contact Allied Telesis for the EU conformity statement. To contact Allied Telesis, visit our web site at [www.alliedtelesis.com/contact](http://www.alliedtelesis.com/contact).

---

## Appendix C

# Radiation Patterns

---

This appendix contains the following sections:

- “Antenna Locations and Axes” on page 56
- “Radiation Patterns for BLE/Zigbee” on page 57
- “Radiation Patterns for Wi-Fi 2GHz” on page 57
- “Radiation Patterns for Wi-Fi 5GHz” on page 58
- “Radiation Patterns for Wi-Fi 6GHz” on page 58

# Antenna Locations and Axes

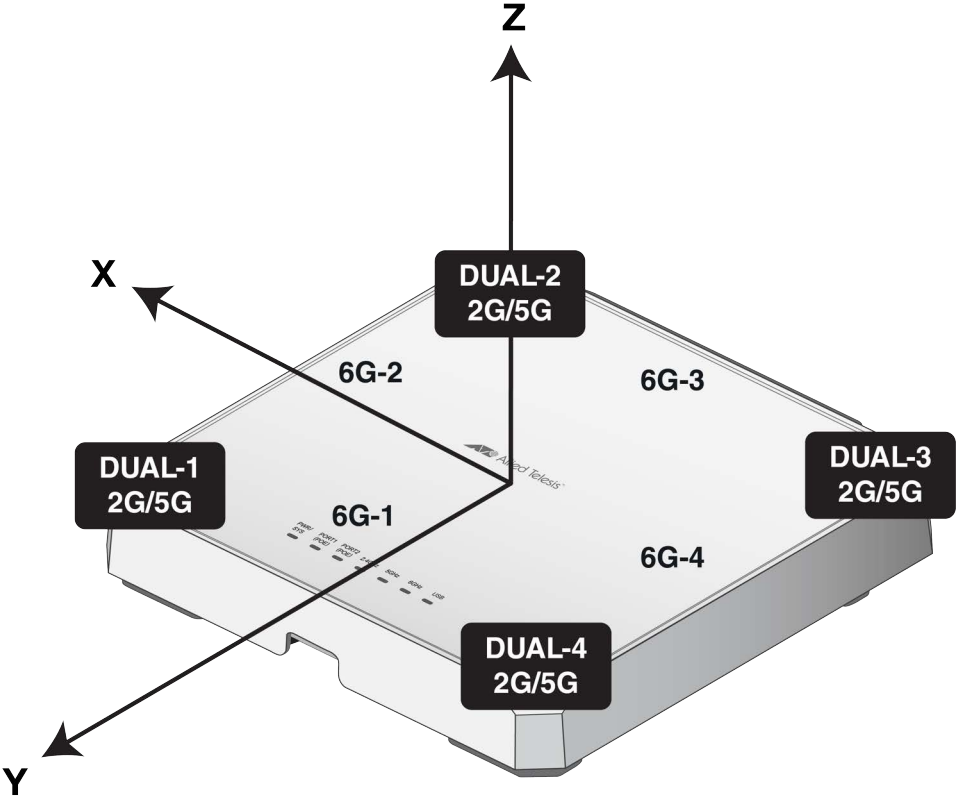
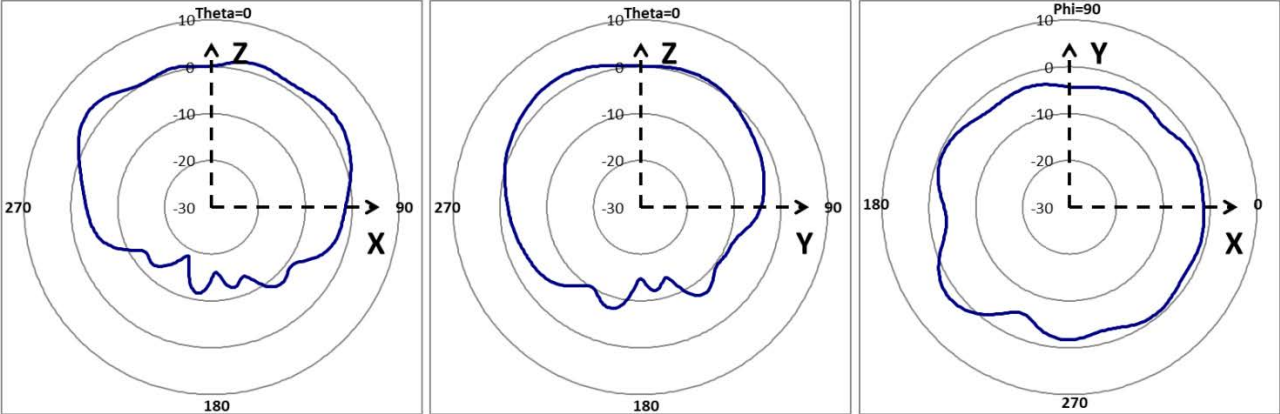

Figure 31. Antenna Locations and Axes

# Radiation Patterns for BLE/Zigbee

## 2GHz Radiation Pattern

— BLE / Zigbee



# Radiation Patterns for Wi-Fi 2GHz

## 2GHz Radiation Pattern

— Directional Gain  
— Dual-1\_2G  
— Dual-2\_2G  
— Dual-3\_2G  
— Dual-4\_2G

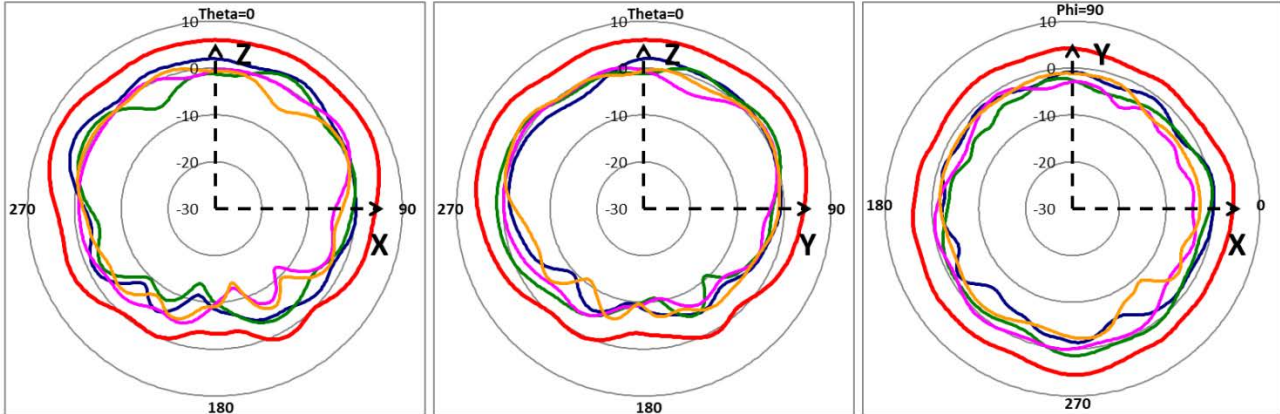

# Radiation Patterns for Wi-Fi 5GHz

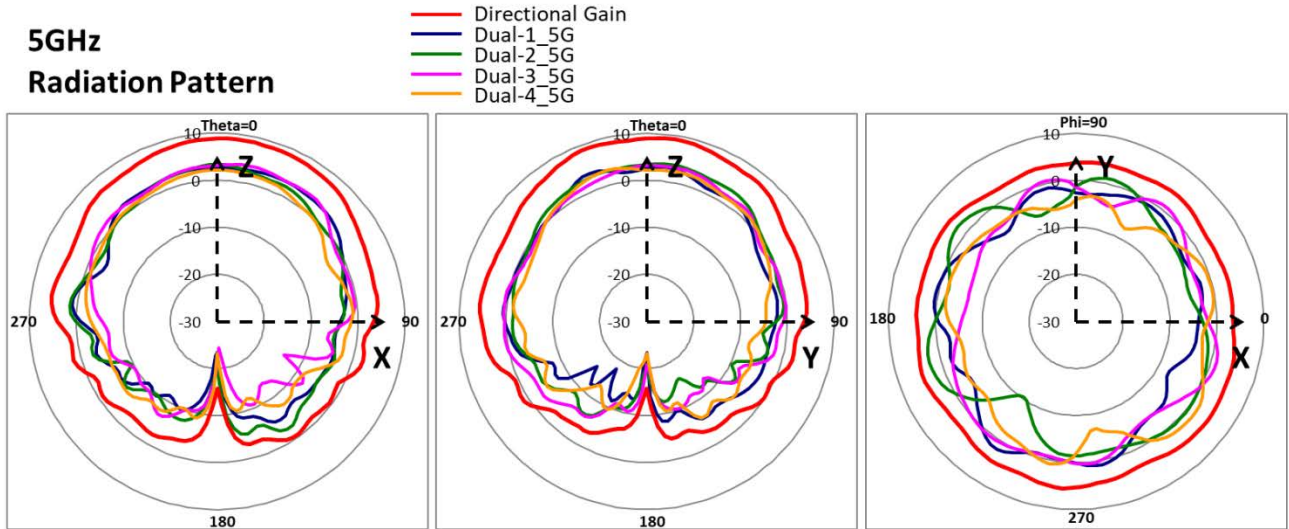

# Radiation Patterns for Wi-Fi 6GHz

