

## TQ7613-R Wireless Access Point

The access point model included in this Quick Installation guide is:

- AT-TQ7613-R

### Note

The TQ7613-R is part of the TQR Series.

## Installation and User's Guides

This document contains an abbreviated version of the installation instructions for the TQ7613-R Wireless Access Points. For complete installation instructions, see the *TQ7613-R Wireless Access Points Installation Guide*.

For management instructions, see *Getting Started with the TQR Series Wireless Router*. The document is on the Allied Telesis web site at [www.alliedtelesis.com/library](http://www.alliedtelesis.com/library).

## Allied OneConnect Onboarding Service

The TQR Series features the OneConnect Onboarding service from Allied Telesis. The service automatically configures managed Allied Telesis products by downloading customized configuration packages from a regional cloud-based OneConnect Onboarding server.

### Please read the following before powering on the access point:

- TQR Series devices automatically start the OneConnect Onboarding service when it receives an IPv4 address from a DHCP server. The port and system LEDs will begin flashing after connecting with the cloud-based service and starting the download process.
- The access point automatically disables the OneConnect Onboarding service if it is not registered with the service.
- OneConnect Onboarding uses SZTP, NTP, DHCP, and DNS to contact its cloud-based server.

For information on Allied OneConnect Onboarding, consult your Allied Telesis Partner or refer to the *Allied OneConnect Onboarding Installation Guide* on the Allied Telesis web site.

## Safety Precautions and Site Requirements

Review the safety precautions and site requirements in the *TQ7613-R Wireless Access Points Installation Guide* before installing the device.

## Package Contents

The wireless access points come with the following items in the shipping container:

- One TQ7613-R Wireless Access Point
- This Quick Installation Guide
- One mounting bracket
- Two M5 x4.5 mm pan-head screws for the mounting bracket

If any item is missing or damaged, contact your Allied Telesis sales representative for assistance. You should retain the original shipping material in case you need to return the unit to Allied Telesis.



613-003433 RevB

## Physical Description

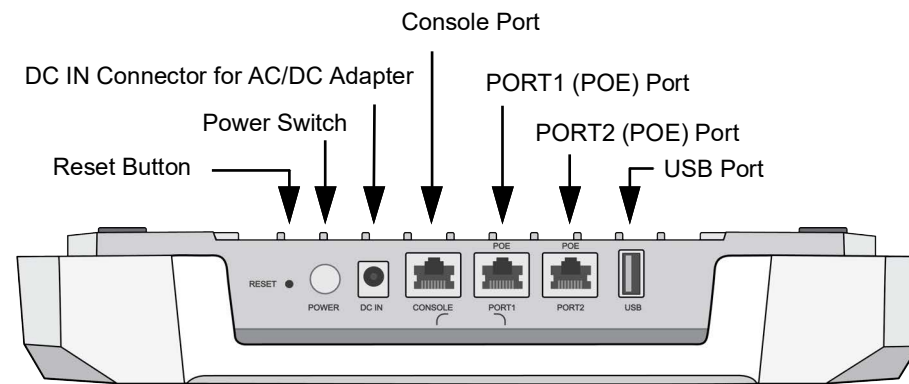

The Console port can be used to access the AlliedWare Plus™ operating system and configure the device.

## Installation Options

You can install the access point on a desktop, ceiling, or wall. See the correct access point orientations:

### Desktop

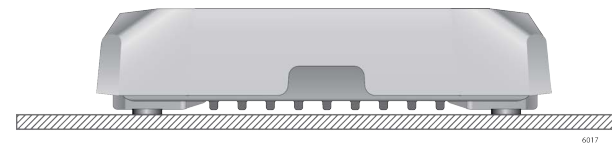

### Ceiling

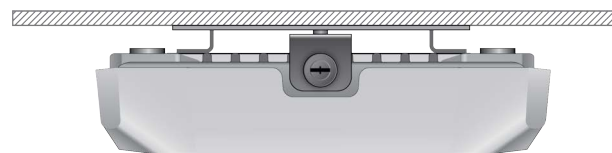

### Wall

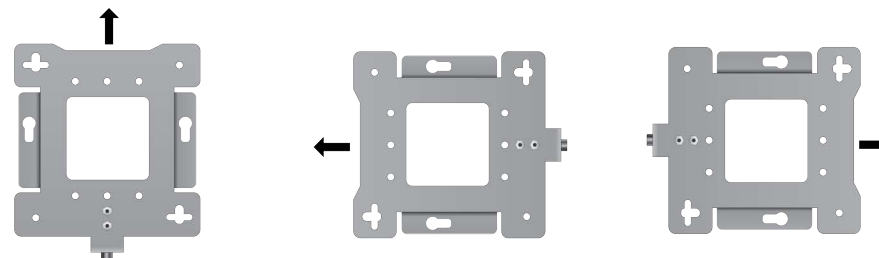

Do not install the access point facing down.

## Pre-fitting the Mounting Bracket

Before installing the mounting bracket on a wall or ceiling, pre-fit the bracket to the access point.

- Place the access point upside down on a table.
- Install the two screws (provided) fully into the bottom panel of the access point.

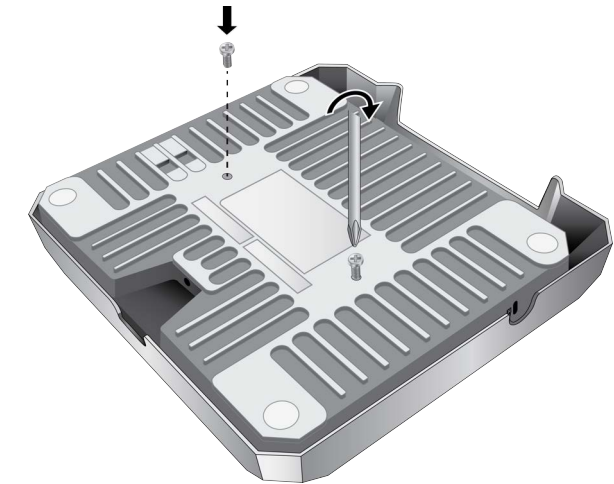

The screw collar provides the proper spacing for the mounting bracket beneath the screw head.



- Make sure that the mounting bracket fits to the access point by sliding the bracket beneath the screws.

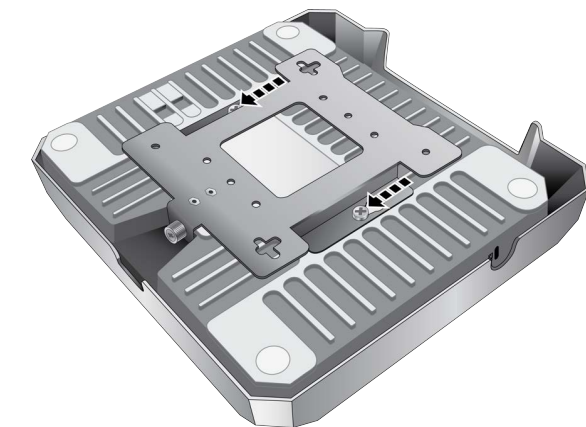

- Slide the mounting bracket forward and remove it from the access point.

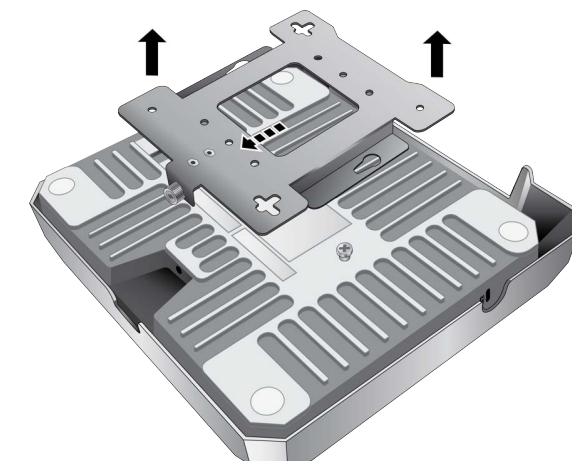

## Installing the Mounting Bracket on a Wall or Ceiling

1. Choose a location and orientation for the access point on the wall or ceiling.
2. Position the mounting bracket at the selected location for the access point. With a pencil, mark the two key-hole slots on the wall or ceiling.

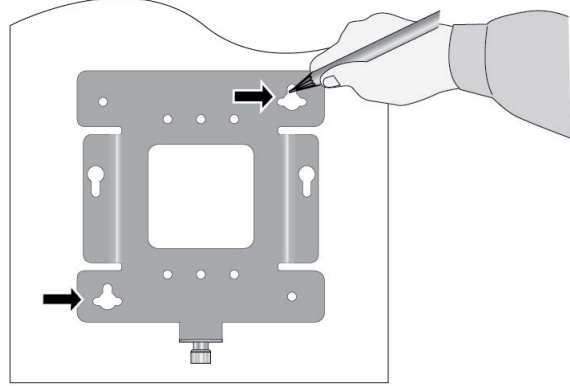

3. If necessary, pre-drill on the wall or ceiling the two marked locations of the key-hole slots for the screws.
4. Install two M4 screws and anchors (if required) into the wall or ceiling. Leave the screws loose enough so that you can slide the bracket under the screw heads. For wooden walls or ceiling, Allied Telesis recommends M4 25 mm flat-head wood screws and anchors (if required). The screws and anchors are not provided.

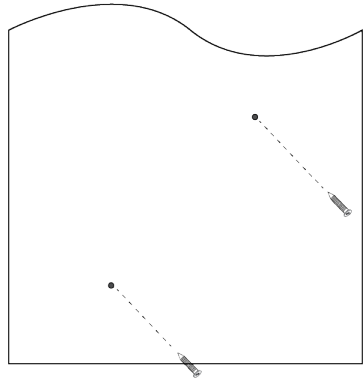

5. Install the openings of the bracket key-hole slots to the two screw heads and slide the bracket into the narrow end of the key-hole slot openings.

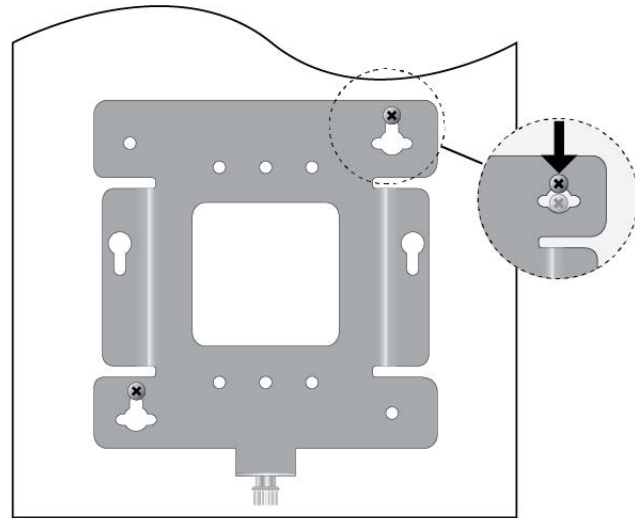

6. Tighten the screws snugly onto the bracket.

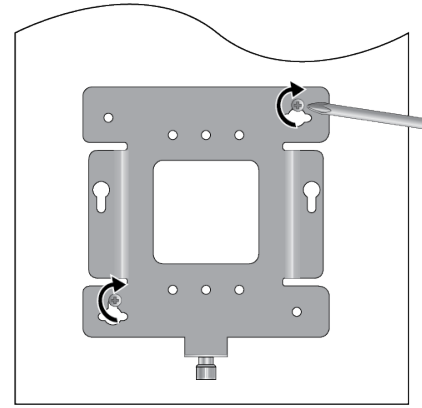

7. To secure the mounting bracket, pre-drill holes through the two bracket mounting holes opposite the key-hole slots.

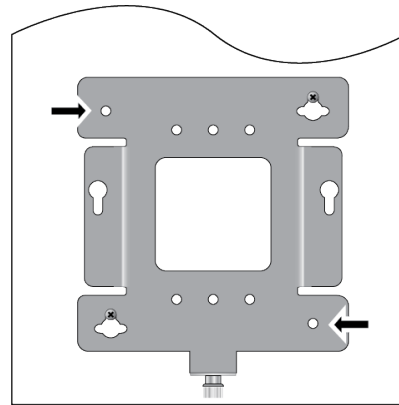

8. Install and tighten two M4 screws (not provided).

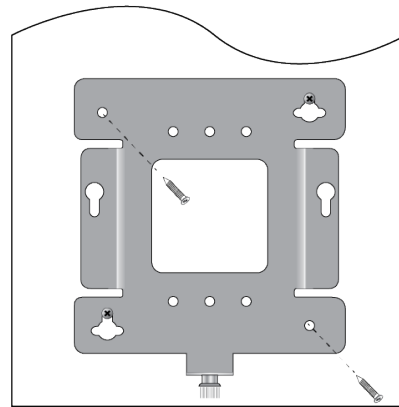

## Cabling the Wireless Access Point

Perform the following procedure to cable the Ethernet LAN port and to power the device:

1. Connect an Ethernet cable to PORT1 port.

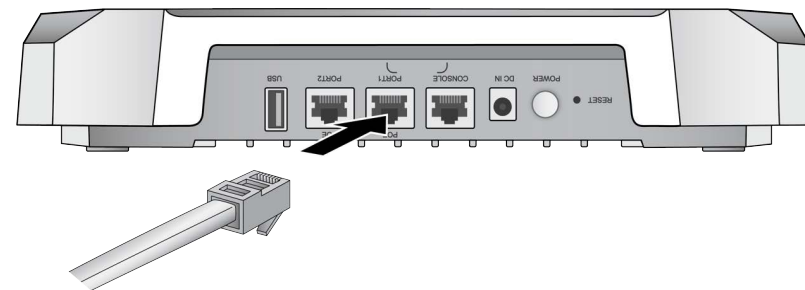

2. Connect the other end of the Ethernet cable to a network device, such as a switch or router.

### Note

When the PORT1 port is connected to PoE++ power sourcing equipment, the TQ7613-R access point powers on and begins to initialize its management software.

3. To use PORT2 in the static LAG or Cascade mode, connect a second Ethernet cable to PORT2 port.

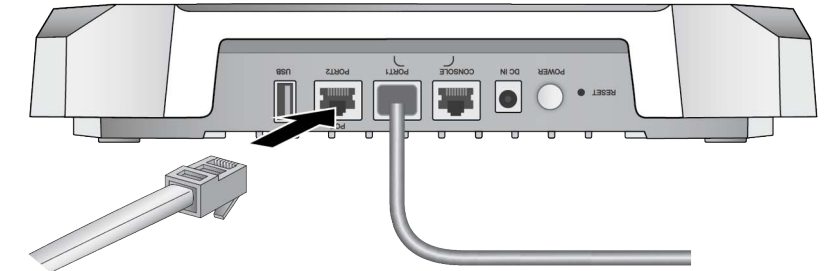

4. Connect the other end of a network device.

To use PORT2 port as a static LAG with PORT1 port, connect PORT2 to the same switch or router as PORT1 port. To use it in the Cascade mode, connect PORT2 to a different device.

### Note

The default setting for PORT2 port is disabled. To enable the port, use the web management interface. For more details, see the *TQ7613-R Management Software User's Guide*.

### Note

Do not enable the PORT2 port until you have configured the other network device for the static LAG.

## Powering the Wireless Access Point

The access point can be powered with PoE++ on the PORT1 or/and PORT2 ports, an external AC/DC power adapter, or both. The access point is powered by both PoE and an external power adapter uses the adapter as its primary power and PoE as redundant power.

Allied Telesis recommends the PWRADP-01 (DA-48Z12) AC/DC Power Adapter. The power adapter is ordered separately.

1. Plug the DC connector into the DC IN jack on the access point.

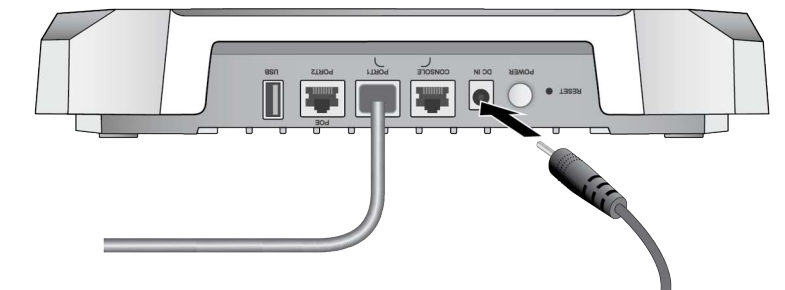

2. Connect the power adapter into an appropriate AC power source.
3. Turn on the Power Switch on the panel.

### Note

The power switch on the access point controls power from the AC power supply. It does not control PoE++ on the PORT1 and PORT2 ports.

## Installing the Access Point on the Wall Mounting Bracket

1. Align the bottom of the access point over the bracket so that the two screws on the bottom of the device fit into the bracket keyholes.

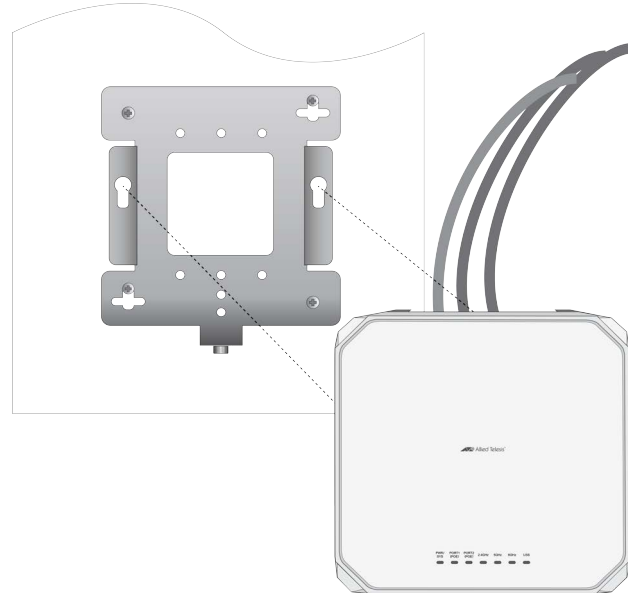

2. Slide the access point forward until its screws are seated in the bracket keyhole slots and the bracket thumbscrew is aligned with the screw hole on the front panel.
3. Tighten the thumbscrew to secure the access point to the wall mounting bracket.

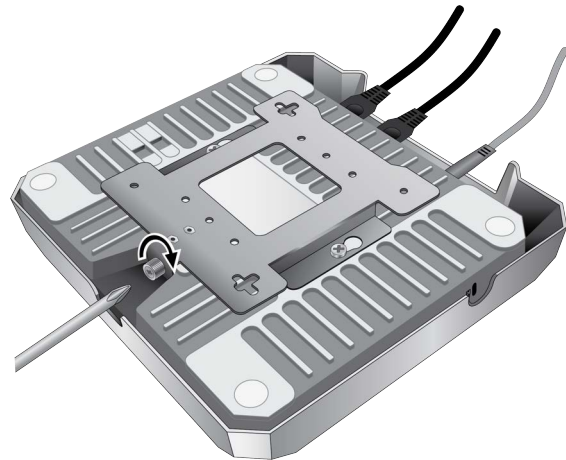

4. Place the Ethernet cable(s) and power cable (if any) along the cable guides inside of the top cover in the cable hiding space.

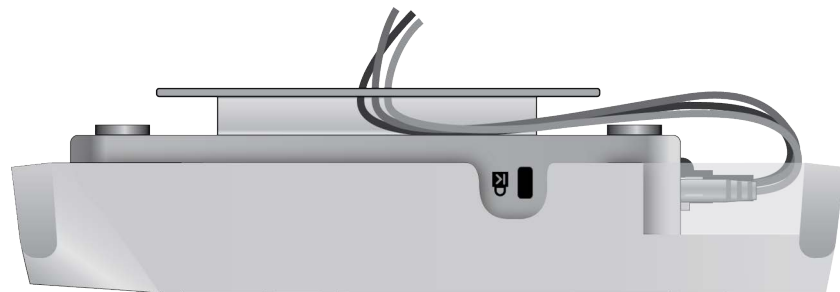

## Installing an Anti-theft Device

Installation of an anti-theft cable/lock is optional.

### Note

Anti-theft devices are not available from Allied Telesis.

1. Follow the instructions provided with the vendor's anti-theft device for the installation.



## Starting the Initial Management Session

The access point firmware includes a DHCP client. The default setting for the client is enabled. When you power on the access point for the first time, it queries the subnet on the LAN port for a DHCP server. If a DHCP server responds to its query, the unit uses the IP address the server assigns to it.

If there is no DHCP server, the access point uses the default IP address of 192.168.1.1

To start the initial management session, perform the following procedure:

1. Start the web browser on your management workstation.
2. Enter the IP address of the wireless access point in the URL field of the web browser. The address is one of the following:
  - If your network does not have a DHCP server, enter the default IP address.
  - If your network has a DHCP server, enter the IP address the DHCP server assigned to the access point.See the following screen as an example.

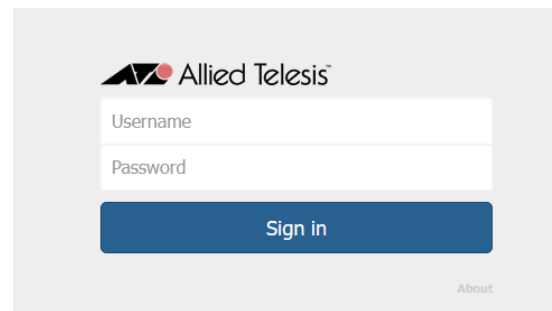

3. Enter "manager" for the username and "friend" for the password. The username and password are case-sensitive.

## Starting a Local Management Session for TQ7613-R

### Note

This section is for the TQ7613-R model only.

The TQ7613-R device can be configured through a local session from the Console port in addition to the Web User Interface.

To start a local management session, perform the following procedure:

1. Connect the RJ-45 end of the management cable to the Console port on the TQ7613-R device.
2. Connect the other end of the cable to an RS-232 port on a terminal or personal computer with a terminal emulation program.
3. Configure a terminal or terminal emulation program as follows:

- Baud rate: 115200 bps
- Data bits: 8
- Parity: None
- Stop bit: 1
- Flow controller: None
- Emulation: VT100

### Note

The port settings are for a DEC VT100 or ANSI terminal, or an equivalent terminal emulator program.

4. Press Enter. You are prompted for a user name and password.
5. Enter "manager" for the username and "friend" for the password. The username and password are case-sensitive.

The local management session starts.

```
awp1us>
```

The AlliedWare™ Plus operating system is installed on the TQ7613-R device.

## Setting the Country Setting

The non-US model of this product has a country code setting that must be set during the initial management session of the unit. The setting ensures that the unit operates in compliance with the laws and regulations of your country or region.

The country code for the US model is preset and cannot be changed. Per FCC regulations, the country code setting for all WiFi products marketed in the US must be fixed to US operational channels only.

## LEDs

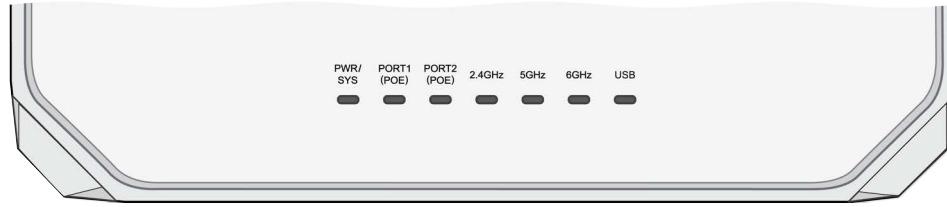

The top panel LEDs are described in this table.

TQ7613-R LED Status Information

LED	State	Description
PWR/ SYS	Green	The access point is powered ON and operating normally.
	Red	The access point has encountered a fault condition.
	Off	The access point is not receiving power.
PORT 1 (POE) and PORT 2 (POE)	Green	The port has established a valid link to a network device.
	Blinking Green	The port is transmitting or receiving data.
	Off	The port has not established a link to a network device.
2.4GHz	Green	The 2.4GHz radio is enabled.
	Off	The 2.4GHz radio is disabled.
5GHz	Green	The 5GHz radio is enabled.
	Off	The 5GHz radio is disabled.
6GHz	Green	The 6GHz radio is enabled.
	Off	The 6GHz radio is disabled.
USB	Green	A USB device is plugged in.
	Blinking Green	Data is being read or written to the USB device.
	Off	The USB feature is disabled in the GUI.

## Product Specifications

The product specifications are listed in the following tables.

Physical Specifications

Parameter	Specification
Dimensions (W x D x H)	265 mm X 265 mm X 45 mm (10.4 in. x 10.4in. x 1.8 in.)
Weight without mounting bracket	1.6 kg (3.53 lbs)
Weight with mounting bracket	1.8 kg (3.97 lbs)

Environmental Specifications

Parameter	Specification
Operating Temperature	0° C to 50° C (32° F to 122° F)
Storage Temperature	- 25° C to 70° C (- 13° F to 158° F)
Operating Humidity	5% to 90% non-condensing
Storage Humidity	0% to 95% non-condensing
Maximum Operating Altitude	3000 m (9843 ft)

Power Specifications on LAN Ports

Parameter	Specification
Maximum Power Consumption	43.5 watts
Rated Voltage	DC 54.5A
Rated Current	1.3A

External AC/DC Power Adapter Specifications

Parameter	Specification
Input Voltage Range	100~240 VAC
Input Frequency	47 - 63 Hz
Rated Output Voltage	+12 VDC
Rated Output Current	4 A
Temperature Ranges	0° C to 50° C (32° F to 122° F)
Maximum Operating Altitude	3000 m (9843 ft)

## Conformity and Regulatory Information

This device complies with Directive 2014/53/EU issued by the Commission of the European Community, some other safety, electromagnetic emission, and radio certificates.

The operating frequencies and maximum transmission power levels for wireless devices operated in the EU are listed below:

EU	Model: AT-TQ7613-R						
(MHz)	2412-2472	2412-2472 (BLE)	2412-2472 (ZigBee)	5150-5250	5250-5350	5470-5725	5925-6425
Beamforming (dBm)	19.96	-	-	22.82	22.84	29.97	22.94
Non-Beamforming (dBm)	19.94	11.17	12.56	22.88	22.95	22.96	22.96

## Note

Operations in the 5.15 - 5.35GHz, and 5.925 - 6.425GHz band are restricted to indoor usage only. Contact Allied Telesis for the EU conformity statement. To contact Allied Telesis, visit the web site at [www.alliedtelesis.com/contact](http://www.alliedtelesis.com/contact).

Copyright © 2026 Allied Telesis, Inc. All rights reserved.

No part of this publication may be reproduced without prior written permission from Allied Telesis, Inc.

Allied Telesis and the Allied Telesis logo are trademarks of Allied Telesis, Incorporated. All other product names, company names, logos or other designations mentioned herein are trademarks or registered trademarks of their respective owners.

Allied Telesis, Inc. reserves the right to make changes in specifications and other information contained in this document without prior written notice. The information provided herein is subject to change without notice. In no event shall Allied Telesis, Inc. be liable for any incidental, special, indirect, or consequential damages whatsoever, including but not limited to lost profits, arising out of or related to this manual or the information contained herein, even if Allied Telesis, Inc. has been advised of, known, or should have known, the possibility of such damages.