

x240 Series

MULTI-GIGABIT SWITCHES

x240-10GHXm PoE++

x240-10GTXm

x240-26GHXm PoE++

x240-26GTXm

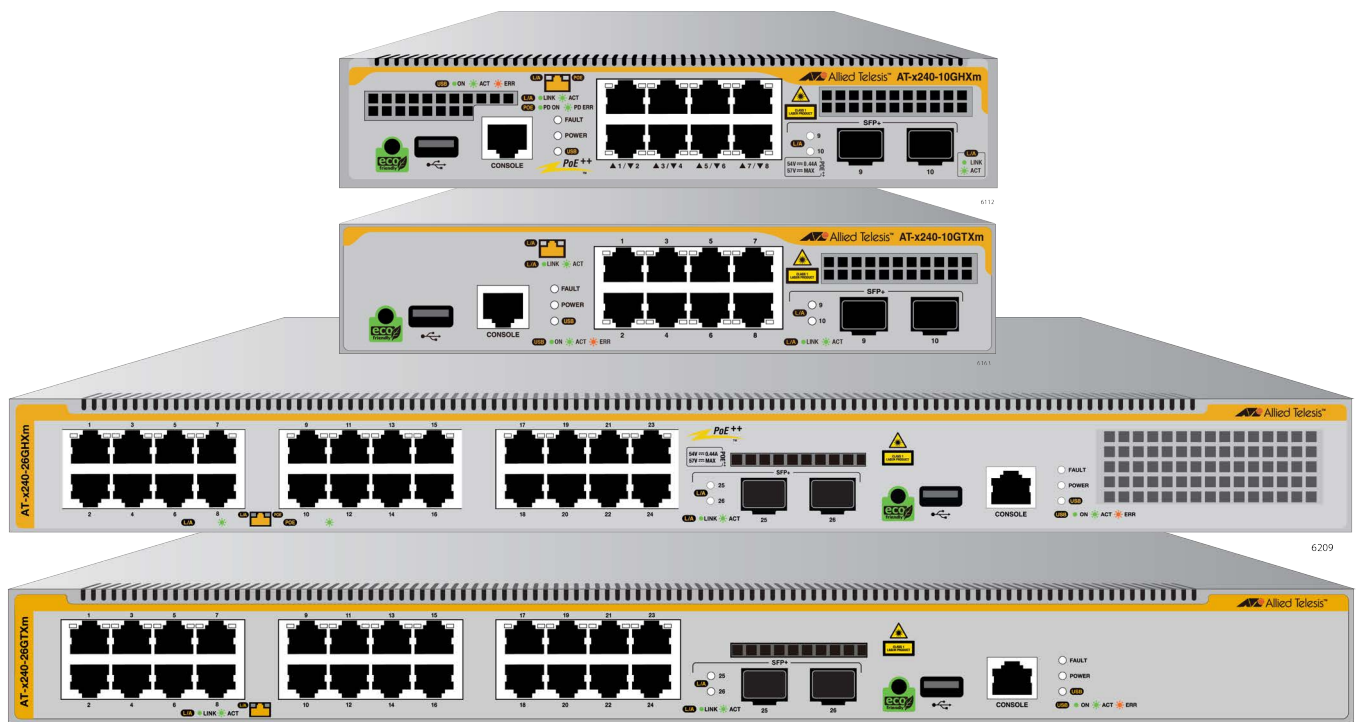

Installation Guide

Copyright © 2025 Allied Telesis, Inc.

All rights reserved. No part of this publication may be reproduced without prior written permission from Allied Telesis, Inc.

Allied Telesis, VCStack, and the Allied Telesis logo are trademarks of Allied Telesis, Incorporated. All other product names, company names, logos or other designations mentioned herein are trademarks or registered trademarks of their respective owners.

Allied Telesis, Inc. reserves the right to make changes in specifications and other information contained in this document without prior written notice. The information provided herein is subject to change without notice. In no event shall Allied Telesis, Inc. be liable for any incidental, special, indirect, or consequential damages whatsoever, including but not limited to lost profits, arising out of or related to this manual or the information contained herein, even if Allied Telesis, Inc. has been advised of, known, or should have known, the possibility of such damages.

Electrical Safety and Emissions Standards

This product meets the following standards.

U.S. Federal Communications Commission

Radiated Energy

Note: This equipment has been tested and found to comply with the limits for a Class A digital device pursuant to Part 15 of FCC Rules. These limits are designed to provide reasonable protection against harmful interference when the equipment is operated in a commercial environment. This equipment generates, uses, and can radiate radio frequency energy and, if not installed and used in accordance with this instruction manual, may cause harmful interference to radio communications. Operation of this equipment in a residential area is likely to cause harmful interference in which case the user will be required to correct the interference at his own expense.

Note: Modifications or changes not expressly approved of by the manufacturer or the FCC, can void your right to operate this equipment.

Industry Canada

This Class A digital apparatus complies with Canadian ICES-003.

Cet appareil numérique de la classe A est conforme à la norme NMB-003 du Canada.

Warning: In a domestic environment this product may cause radio interference in which case the user may be required to take adequate measures. ⚡ **E84**

Industry Canada

Radiated Energy

This Class A digital apparatus complies with Canadian ICES-003 Class A.

Cet appareil numérique de la classe A est conforme à la norme NMB-003 du Canada.

VCCI Statement

この装置は、クラスA情報処理装置です。この装置を家庭環境で使用すると電波妨害を引き起こすことがあります。この場合には使用者が適切な対策を講ずるよう要求されることがあります。VCCI-A

Regulatory Approvals

Compliance Marks

- ❑ CE, CULUS, UL-EU, RCM

Electromagnetic Emissions

- ❑ FCC Part 15 Subpart B, Class A
Information Technology Equipment for industrial environments
- ❑ ICES 003 Class A
Information Technology Equipment (Including Digital Apparatus) - Limits and Methods of Measurement (Canadian Standard)
- ❑ EN 55032 Class A
Electromagnetic compatibility of multimedia equipment. Emission requirements
- ❑ CISPR 32 Class A
Electromagnetic compatibility of multimedia equipment - Emission requirements
- ❑ VCCI Class A
Electromagnetic compatibility of multimedia equipment. Emission requirements (Japanese Standard)
- ❑ RCM AS/NZS CISPR 32 Class A
Electromagnetic compatibility of multimedia equipment - Emission requirements

Electromagnetic Immunity

- ❑ EN 55035
Electromagnetic compatibility of multimedia equipment — Immunity requirements

Electrical and Laser Safety

- ❑ UL 62368-1
Audio/video, information and communication technology equipment - Part 1: Safety requirements;
- ❑ CSA C22.2 NO. 62368-1
Audio/video, information and communication technology equipment - Part 1: Safety requirements (Canadian Standards Association)

- ❑ EN 62368-1

Audio/video, information and communication technology equipment - Part 1: Safety requirements;

- ❑ IEC 62368-1

Audio/video, information and communication technology equipment - Part 1: Safety requirements;

- ❑ EN (IEC) 60825-1¹

Safety of laser products

Environmental Compliance

Restriction of Hazardous Substances - RoHS

Waste from Electrical and Electronic Equipment - WEEE



Laser Safety

EN (IEC) 60825-1

1. The product supports SFP/SFP+ optical transceivers that are EN (IEC) 60825-1 certified. The product itself is not EN (IEC) 60825-1 certified.

Translated Safety Statements

Important: Safety statements with the  symbol are translated into multiple languages in **Translated Safety Statements** at alliedtelesisis.com/us/en/library/search.

Übersetzte Sicherheitshinweise

Wichtig: Sicherheitshinweise mit dem -Symbol werden in **Translated Safety Statements** bei alliedtelesisis.com/us/en/library/search in mehrere Sprachen übersetzt.

Declaraciones de seguridad traducidas

Importante: Las declaraciones de seguridad con el símbolo  se traducen a varios idiomas en **Translated Safety Statements** en alliedtelesisis.com/us/en/library/search.

Consignes de sécurité traduites

Important: Les déclarations de sécurité avec le symbole  sont traduites en plusieurs langues en **Translated Safety Statements** sur alliedtelesisis.com/us/en/library/search.

Dichiarazioni di sicurezza tradotte

Importante: Le dichiarazioni di sicurezza con il simbolo  sono tradotte in più lingue in **Translated Safety Statements** su alliedtelesisis.com/us/en/library/search.

Översatta säkerhetsförklaringar

Viktig: Säkerhetsföreskrifter med -symbolen översätts till flera språk på **Translated Safety Statements** vid alliedtelesisis.com/us/en/library/search.

Contents

Preface:	11
Document Conventions	12
Contacting Allied Telesis	13
Chapter 1: Overview	15
Front and Rear Panels	16
x240-10GHXm Front Panel	16
x240-10GTXm Front Panel	16
x240-26GHXm Front Panel	16
x240-26GTXm Front Panel	17
x240-10GHXm Rear Panel	17
x240-10GTXm Rear Panel	17
Rear Panel of x240-26GHXm and x240-26GTXm	18
Management Panel	19
Features	20
x240 Models	20
10/100M/1/2.5/5G Copper Ports	20
1/10G SFP+ Ports	21
Power Over Ethernet	21
LEDs	22
Installation Options	22
Management Software and Interfaces	22
Console Port	22
USB Port	23
Management Methods	23
MAC Address Table	23
Energy Savings	23
10M/100M/1G/2.5G/5G Copper Ports	24
Connector Type	24
Speed	24
Duplex Mode	24
Maximum Distance	24
Cable Requirements	24
Automatic MDIX Detection	25
x240-10GHXm and x240-26GHXm LEDs	25
x240-10GTXm and x240-26GTXm LEDs	27
Power Over Ethernet (PoE) on the x240-10GHXm and x240-26GHXm Switches	28
PoE Standards	28
Powered Device Classes	28
Power Budget	29
Port Priorities	30
Wiring Implementation	30
SFP+ Transceiver Ports	32
SFP+ Transceivers	32
LEDs	32
Fault and Power LEDs	33
eco-friendly Button	35
USB Port	36
USB Port LED	36

Console Port	37
Power Supply and Fan	39
Power Supply	39
Fan	39
Chapter 2: Beginning the Installation	41
Reviewing Safety Precautions	42
Choosing a Site for the Switch	46
Unpacking the x240-10GHXm or x240-10GTXm Switch	47
Unpacking the x240-26GHXm or x240-26GTXm Switch	48
x240-10GHXm and x240-10GTXm Installation Options	49
x240-26GHXm and x240-26GTXm Installation Options	50
Accessory Hardware	51
Recording the Serial Number and MAC Address	53
Chapter 3: Installing the Switch on a Table or Desktop	55
Chapter 4: Installing the Switch in an Equipment Rack	57
Overview of Installing the Switch in an Equipment Rack	58
x240-10GHXm and x240-10GTXm Switches	58
x240-26GHXm and x240-26GTXm Switches	59
Installing the x240-10GHXm and x240-10GTXm Switches in an Equipment Rack with the RKMT-J14 Brackets	60
Required Items	60
Switch Orientations in the Equipment Rack	60
Installing the Switch	62
Installing the x240-10GHXm and x240-10GTXm Switches in an Equipment Rack with the RKMT-J15 Bracket	65
Required Items	65
Installing the Switch	65
Installing the x240-26GHXm or x240-26GTXm Switch in an Equipment Rack	71
Required Items	71
Switch in the Equipment Rack	71
Installing the Switch	72
Chapter 5: Installing the Switch on a Wall Using the BRKT-J24 Wall Mount Kit	75
Switch Orientations on a Wall	76
Installation Guidelines	77
Tools and Material	77
Installing the Switch on a Wall Using the BRKT-J24 Brackets	78
Chapter 6: Cabling the Networking Ports	85
Cabling Copper Ports	86
Installing SFP and SFP+ Transceivers	88
Installing SFP and SFP+ Transceiver	89
Installing SP10TW Direct Connect Cables	92
Installing SP10TW Direct Connect Cable	92
Chapter 7: Powering On the Switch	95
Powering On the Switch	96
Chapter 8: Managing the Switch	99
Starting a Management Session	100
Through the Console Port	100
With a DHCP Server	102
With the Default IPv4 Address	103
Verifying the Switch	105
Specifying Ports in the Command Line Interface	106
Chapter 9: Management Stacking	107
Overview	108
Command Node	108
Node	108
Management Stack	108
Setting Up a Management Stack	109
Step 1: Configuring the Command Node	109

Step 2: Configuring Node-01.....	110
Step 3: Configuring Node-02.....	111
Checking the Status of the Stack.....	112
Running Commands on Devices in the Management Stack.....	113
Copying Files Between Management Stack Members.....	114
Using Remote Login to Copy Files Between Other Units in the Management Stack.....	114
Chapter 10: Troubleshooting	115
Appendix A: Technical Specifications	119
Physical Specifications	120
Environmental Specifications	123
Power Specifications	124
RJ-45 Copper Port Pinouts	125
RJ-45 Style Serial Console Port Pinouts.....	127
Console Management Cable with DB-9 Female and RJ-45 Connectors	128

Preface

The x240 series devices are Multi-Gigabit Ethernet switches. This guide contains the installation instructions for the following products:

- ❑ x240-10GHXm
- ❑ x240-10GTXm
- ❑ x240-26GHXm
- ❑ x240-26GTXm

This preface contains the following sections:

- ❑ “Document Conventions” on page 12
- ❑ “Contacting Allied Telesis” on page 13

Document Conventions

This document uses the following conventions:

Note

Notes provide additional information.



Caution

Cautions inform you that performing or omitting a specific action may result in equipment damage or loss of data.



Warning

Warnings inform you that performing or omitting a specific action may result in bodily injury.

Contacting Allied Telesis

If you need assistance with this product, visit the Allied Telesis web site at **www.alliedtelesis.com/services**.

Chapter 1

Overview

This chapter contains the following sections:

- ❑ “Front and Rear Panels” on page 16
- ❑ “Management Panel” on page 19
- ❑ “Features” on page 20
- ❑ “10M/100M/1G/2.5G/5G Copper Ports” on page 24
- ❑ “Power Over Ethernet (PoE) on the x240-10GHXm and x240-26GHXm Switches” on page 28
- ❑ “SFP+ Transceiver Ports” on page 32
- ❑ “Fault and Power LEDs” on page 33
- ❑ “eco-friendly Button” on page 35
- ❑ “USB Port” on page 36
- ❑ “Console Port” on page 37
- ❑ “Power Supply and Fan” on page 39

Front and Rear Panels

This section shows the front and rear panels of the x240 series switches.

x240-10GHXm Front Panel

The front panel of x240-10GHXm switch with PoE++ is shown in Figure 1.

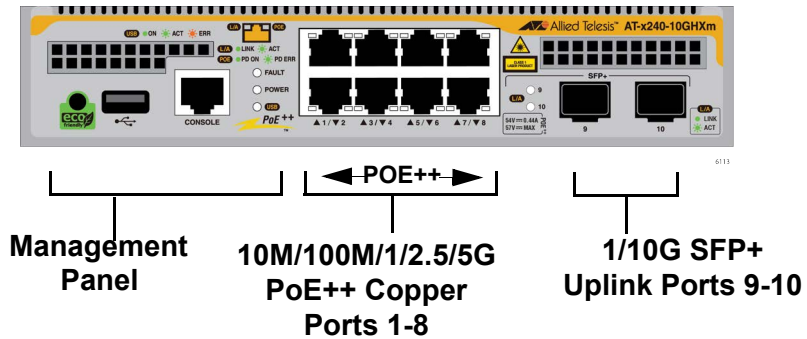

Figure 1. Front Panel of the x240-10GHXm Switch

x240-10GTXm Front Panel

The front panel of the x240-10GTXm switch is shown in Figure 2.

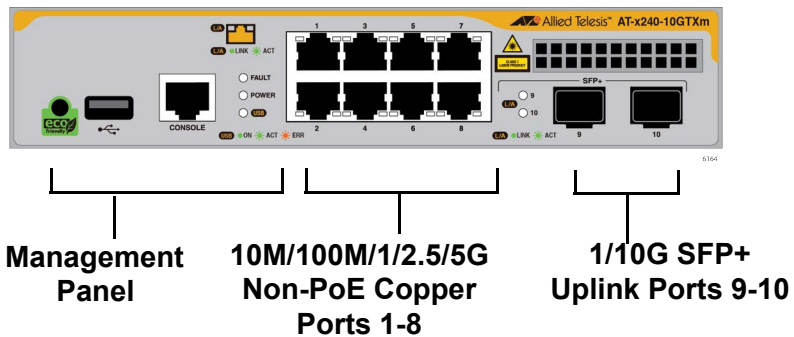

Figure 2. Front Panel of the x240-10GTXm Switch

x240-26GHXm Front Panel

The front panel of the x240-26GHXm switch with PoE++ is shown in Figure 3.

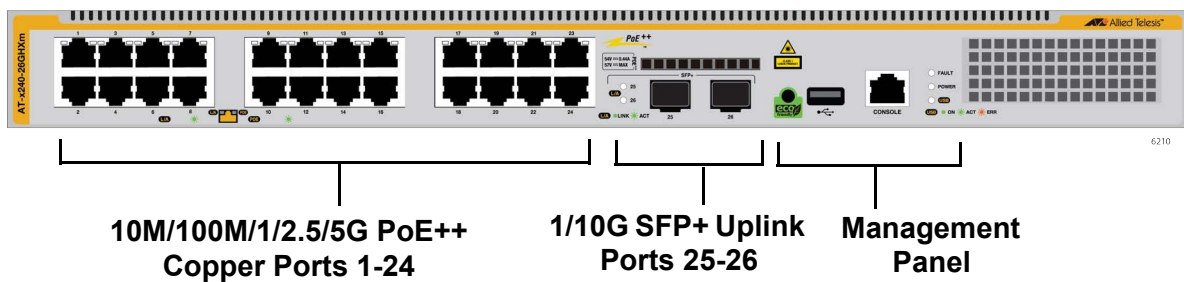

Figure 3. Front Panel of the x240-26GHXm Switch

x240-26GTXm Front Panel The front panel of the x240-26GTXm Switch is shown in Figure 4.

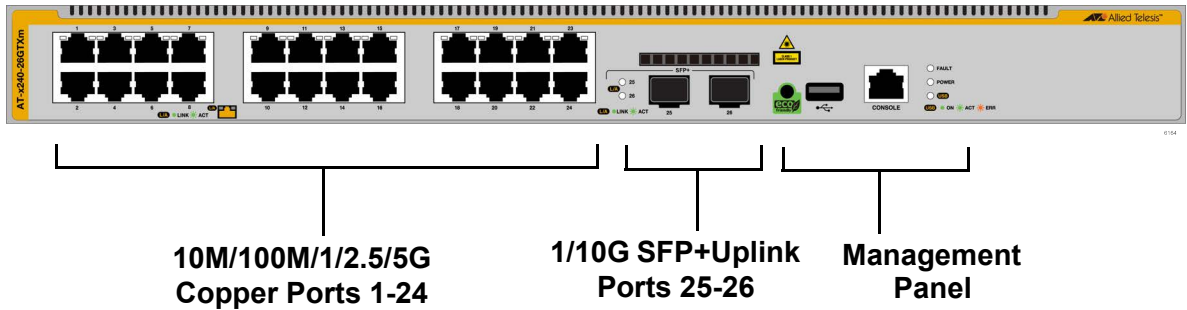

Figure 4. Front Panel of the x240-26GTXm Switch

x240-10GHXm Rear Panel The rear panel of the x240-10GHXm Switch is shown in Figure 5.

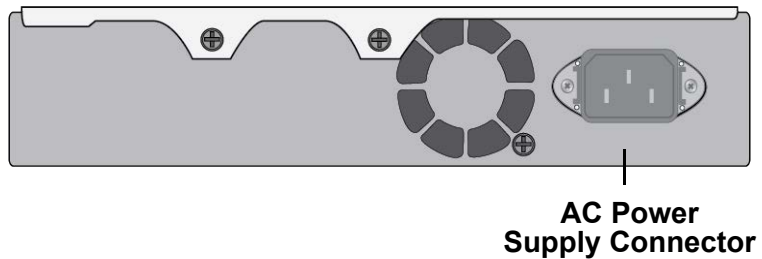

Figure 5. Rear Panel of the x240-10GHXm Switch

x240-10GTXm Rear Panel The rear panel of the x240-10GTXm Switch is shown in Figure 6.

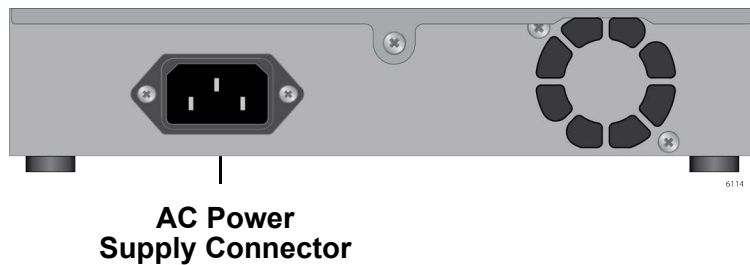

Figure 6. Rear Panel of the x240-10GTXm Switch

**Rear Panel of
x240-26GHXm
and
x240-26GTXm**

The rear panel of the x240-26GHXm and x240-26GTXm switches is shown in Figure 7.

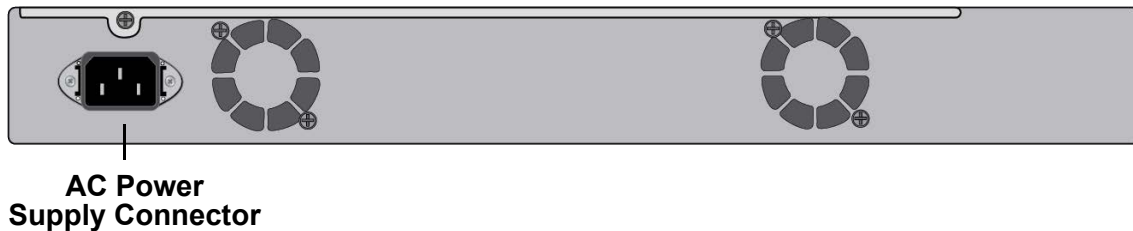

Figure 7. Rear Panel of the x240-26GHXm and x240-26GTXm Switches

Management Panel

Figure 8 identifies the components on the management panel.

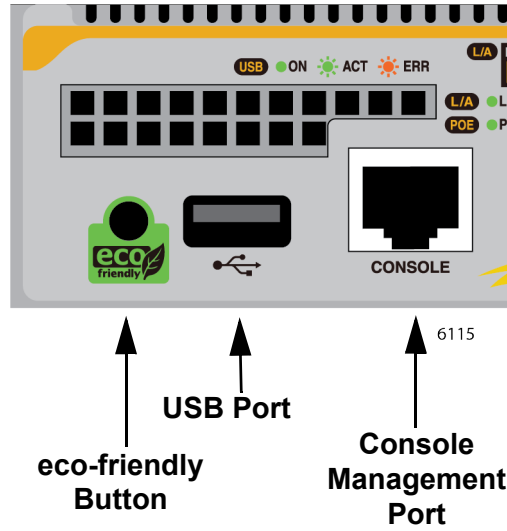

Figure 8. Management Panel

Features

The following sections review the hardware features of the multi-gigabit switches in the x240 Series.

x240 Models Table 1 lists the basic features.

Table 1. Basic Features

Model	10M/100M/ 1/2.5/5G PoE++ Copper Ports	10M/100M/ 1/2.5/5G Copper Ports	1/10G SFP+ Uplink Ports	PoE Power Budget
x240-10GHXm	8	-	2	240W
x240-10GTXm	N/A	8	2	N/A
x240-26GHXm	24	-	2	370W
x240-26GTXm	N/A	24	2	N/A

10/100M/1/2.5/5G Copper Ports The copper ports on the x240 series switches have these features:

- ❑ Speeds of 10/100M/1/2.5/5G
- ❑ 100 meters (328 feet) maximum operating distance per port
- ❑ Full-duplex mode
- ❑ Auto-Negotiation for speed and duplex mode
- ❑ Port Link/Activity (L/A) LEDs
- ❑ Automatic MDIX detection at 10 or 100Mbps
- ❑ IEEE 802.3az 10Base-Te
- ❑ IEEE 802.3u 100Base-TX
- ❑ IEEE 802.3ab 1000Base-T
- ❑ IEEE 802.3bz 2.5GBase-T and 5GBase-T
- ❑ IEEE 802.3u Auto-Negotiation
- ❑ IEEE 802.3ad Link Aggregation
- ❑ Jumbo frames up to 10KB
- ❑ RJ-45 connectors

1/10G SFP+ Ports The 1/10G SFP+ uplink ports support the following types of transceivers:

Examples of SFP 1Gbps transceivers include:

- ❑ SPSX and LR short and long distance transceivers using multi-mode or single mode fiber optic cable.
- ❑ SPBD series of bidirectional transceivers with maximum distances of 10/20/40/80 kilometers.
- ❑ SPTXa is a 1G transceiver with an RJ-45 connector for a copper link of up to 100m with Category 5e cable.

Examples of SFP+ 10Gbps transceivers include:

- ❑ SP10SR, LR, ER and ZR series of short and long distance transceivers using multi-mode or single mode fiber optic cable.
- ❑ SP10BD 10G bidirectional transceivers use single mode fiber optic cable and have distances of 10/20/40/80 kilometers.
- ❑ SP10TM 1/2.5/5/10G transceiver with RJ-45 connector for a copper link of up to 30m for 10G over Category 6A cable and 100m for 5G Category 5e cable.

Note

Industrial (-40 to 85° C) and extended (-40 to 105° C) temperature transceivers are available.

Note

For a current list of supported transceiver modules refer to the *x240 Series Data Sheet*.

Power Over Ethernet

Here are the basic features of PoE++ on the copper ports:

- ❑ x240-10GHXm:
 - Supported on all 8 copper ports
 - 240W power budget
- ❑ x240-26GHXm:
 - Supported on all 24 copper ports
 - 370W power budget

The x240-10GHXm and x240-26GHXm ports support these PoE standards:

- ❑ PoE: IEEE 802.3af, IEEE 802.3at Type 1 (15.4W)
- ❑ PoE+: IEEE 802.3at Type 2 (30W)
- ❑ PoE++: IEEE 802.3bt Type 3 (60W) and Type 4 (90W)

Additional PoE capabilities include:

- Support powered device classes 0 to 8.
- Dynamic PoE power budget allocation, according to powered device consumptions and/or PoE port priorities.
- Uninterrupted PoE during warm switch restarts.

LEDs Here are the port LEDs:

- The SFP transceiver ports have link/activity LEDs.
- The PoE++ copper ports on x240-10GHXm and x240-26GHXm switches have link/activity and PoE status LEDs.
- The non-PoE copper ports on the x240-10GTXm and x240-26GTXm switches have link/activity and Duplex LEDs.
- The management panel has system LEDs for the power supply, USB slot and SYS/FAULT.

You can use the eco-friendly button to turn off the port LEDs to conserve electricity.

Installation Options

Here are the installation options:

- Desk or tabletop
- Standard 19-inch equipment rack
- Wood or concrete wall

Management Software and Interfaces

Here are the management software and interfaces:

- AlliedWare Plus Management Software
- Local management through the Console port
- Remote Telnet and Secure Shell management
- Command line interface
- SNMPv1, v2c, and v3
- AMF or Management Stacking (they cannot be used at the same time)

Console Port

The port is used for local management of the switch. The port settings are provided in “Console Port” on page 37. The port pinouts are provided in “RJ-45 Style Serial Console Port Pinouts” on page 127.

USB Port Here are the features and functions of the USB port:

- USB 2.0 compatible
- Store switch configuration files on flash drives
- Restore configuration files from flash drive to switches whose settings have been lost or corrupted, or to configure replacement units
- Update the AlliedWare Plus Management Software

Management Methods Here are the methods for managing the switches:

- Local management through the Console port
- Remote Telnet or Secure Shell management
- SNMPv1, v2c, and v3

MAC Address Table Here are the basic features of the MAC address table:

- Storage capacity of 32K MAC address entries
- Automatic learning and aging

Energy Savings Here are energy saving features:

- eco-friendly button for turning on and off the port LEDs
- IEEE 802.3az Energy-Efficient Ethernet (EEE)

10M/100M/1G/2.5G/5G Copper Ports

The following sections describe the copper ports on the x240 series switches.

Connector Type The copper ports have 8-pin RJ-45 connectors. The ports use four pins at 10/100Mbps and all eight pins at 1G/2.5G/5G. The pin assignments are listed in “RJ-45 Style Serial Console Port Pinouts” on page 127.

Speed The ports can operate at 10M/100M/1G/2.5G/5G. The switch can set the speeds automatically through Auto-Negotiation, the default setting, or you can manually configure them with the AlliedWare Plus Operating System.

Note

Copper ports have to be set to Auto-Negotiation to operate at 1000Mbps or higher.

Duplex Mode The copper ports on the switches can only operate in full-duplex mode at 10/100/1G. The copper ports are IEEE 802.3u-compliant and use Auto-Negotiate to set the duplex mode setting.

You can disable Auto-Negotiation on the ports and set the duplex mode manually.

Maximum Distance The ports have a maximum operating distance of 100 meters (328 feet).

Cable Requirements The minimum cable requirements for the ports are listed here.

- ❑ 10M: Standard TIA/EIA 568-compliant Category 3, 100 ohm unshielded cabling, complying with IEEE 802.3i 10Base-T specifications.
- ❑ 100M: Standard TIA/EIA 568-compliant Category 5, 100 ohm unshielded cabling, complying with IEEE 802.3u 100Base-TX specifications.
- ❑ 1/2.5/5G: Standard TIA/EIA 568-A-compliant Category 5 or TIA/EIA 568-B-compliant Enhanced Category 5 (Cat 5e) unshielded cabling.

Automatic MDIX Detection

The copper ports are IEEE 802.3ab compliant. They feature automatic MDIX detection when operating at 10 or 100Mbps. (Automatic MDIX detection does not apply to higher speeds.) The switch automatically configures the ports to MDI or MDI-X depending on the wiring configurations of the end nodes.

Ports connected to network devices that do not support automatic MDIX detection default to MDIX.

You can disable automatic MDIX detection on the individual ports and configure the MDI/MDI-X settings manually with the `POLARITY` command.

Refer to “RJ-45 Copper Port Pinouts” on page 125 and “RJ-45 Style Serial Console Port Pinouts” on page 127 for the port pinouts of the copper ports.

x240-10GHXm and x240-26GHXm LEDs

The PoE++ copper ports on the x240-10GHXm and x240-26GHXm Switches have two LEDs. The LEDs are shown in Figure 9.

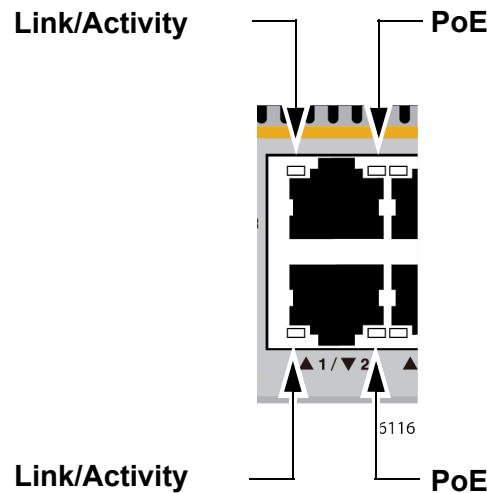

Figure 9. LEDs for the Copper Ports on the x240-10GHXm and x240-26GHXm Switches

The states of the port LEDs are described in Table 2 on page 26.

Table 2. LEDs for PoE Ports on the x240-10GHXm and x240-26GHXm

State	Description
Link/Activity LED (Left LED)	
Solid Green	The port has established a link to a network device.
Flashing Green	The port is transmitting or receiving packets.
Off	Possible causes of this state are listed here: <ul style="list-style-type: none"> ❑ The port has not established a link with another network device. ❑ The LEDs are turned off. To turn on the LEDs, use the eco-friendly button.
PoE LED (Right LED) 10M/100M/1G/2.5G/5G Ports (PoE model)	
Solid Green	The port is delivering power to a powered device.
Flashing Green	The switch has detected a powered device on the port, but the switch has experienced a fault condition or cannot supply power to the powered device because the switch is already providing its maximum power to other devices. The maximum power budget are: <ul style="list-style-type: none"> ❑ x240-10GHXm: 240W ❑ x240-26GHXm: 370W
Off	This LED state can result from the following conditions: <ul style="list-style-type: none"> ❑ The port is not connected to a powered device or the device is powered off. ❑ The port is disabled in the management software. ❑ PoE is disabled on the port. ❑ The LEDs are turned off. To turn on the LEDs, use the eco-friendly button.

**x240-10GTXm
and
x240-26GTXm
LEDs**

The non-PoE copper ports on the x240-10GTXm and x240-26GTXm switches have two LEDs. The LEDs are shown in Figure 10.

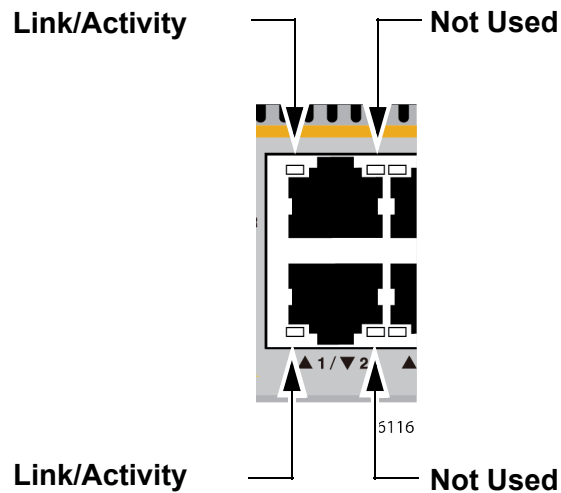

Figure 10. LEDs for the Copper Ports on the x240-10GTXm and x240-26GTXm Switches

The states of the port LEDs are described in Table 3 on page 27.

Table 3. LEDs for the Ports on the x240-10GTXm and x240-26GTXm

State	Description
Link/Activity LED (Left LED)	
Solid Green	The port has established a 1/2.5/5G link to a network device.
Flashing Green	The port is transmitting or receiving 1/2.5/5G packets.
Off	Possible causes of this state are listed here: <ul style="list-style-type: none"> <input type="checkbox"/> The port has not established a link with another network device. <input type="checkbox"/> The LEDs are turned off. To turn on the LEDs, use the eco-friendly button.
Not Used (Right LED)	
Off	This LED is not used.

Power Over Ethernet (PoE) on the x240-10GHXm and x240-26GHXm Switches

The x240-10GHXm and x240-26GHXm Switches feature PoE++ on all 10M/100M/1G/2.5G/5G copper ports. With PoE++, the switch can supply DC power to network devices over the same copper cables that carry the network traffic.

PoE++ can make it easier to install networks. The selection of a location for a network device is often limited by whether there is a power source nearby. This often limits equipment placement or requires the added time and cost of having additional electrical sources installed. But with PoE, you can install PoE-compatible devices wherever they are needed without having to worry about whether there are power sources nearby.

Devices such as the x240-10GHXm and x240-26GHXm Switches that provide PoE to network devices are referred to as *power sourcing equipment* (PSE). They function as a central power sources for other network devices.

Devices that receive their power from a PSE are called *powered devices* (PD). Examples include wireless access points, IP telephones, webcams, and even other Ethernet switches.

The switch automatically determines whether or not devices connected to its ports are powered devices. Ports that are connected to network nodes that are not powered devices (that is, devices that receive their power from another power source) function as regular Ethernet ports, without PoE. The PoE feature remains activated on the ports but no power is delivered to the devices.

PoE Standards

The x240-10GHXm and x240-26GHXm Switches support these PoE standards:

- ❑ PoE IEEE 802.3af and IEEE 802.3at Type 1 supplying up to 15.4W at a switch port.
- ❑ PoE+ IEEE 802.3at Type 2 supplying up to 30W at a switch port.
- ❑ PoE++ IEEE 802.3bt Types 3 and 4 supplying up to 60/90W at a switch port.

Powered Device Classes

Powered devices are grouped into the nine classes listed in Table 4 on page 29. The classes are based on the amount of power the devices require. The switches support all nine classes.

Table 4. IEEE Powered Device Classes

Class	Maximum Power Output from a Switch Port	PD Power Range
0	15.4W	0.44W to 12.95W
1	4.0W	0.44W to 3.84W
2	7.0W	3.84W to 6.49W
3	15.4W	6.49W to 12.95W
4	30.0W	12.95W to 25.5W
5	45.0W	40.0W
6	60.0W	51.0W
7	75.0W	62.0W (4-pair)
8	90.0W	71.3W (4-pair)

Power Budget

The x240-10GHXm Switch has a power budget of 240W and the x240-26GHXm Switch has a power budget of 370W. This is the total maximum amount of power that the switch can supply to the powered devices on its copper ports.

To determine the maximum number of PoE devices the switch can support at one time, compare their power requirements against its power budget. The switch can supply power to all devices provided their total power requirement is less than its power budget. If the total power requirement of the devices exceed the power budget, the switch will deny power to one or more ports using port priorities.

The switch can handle different power requirements on different ports. This enables you to connect different classes of PoE equipment to the ports on the switch.

Table 5. PoE Requirements

Model Name	PoE Power Consumption	Maximum Ports Supported				
		7W	15.4W	30W	60W	90W
x240-10GHXm	240W	8	8	8	4	2
x240-26GHXm	370W	24	24	12	6	4

Port Priorities

If the switch determines that the power requirements of the powered devices exceed its power budget, it will deny power to some ports based on a system called port priorities. You can use this mechanism to ensure that powered devices critical to the operations of your network are given preferential treatment by the switch in the distribution of power should the demands of the devices exceed the available capacity.

There are three port priority levels:

- Critical
- High
- Low

Ports set to the Critical level, the highest priority level, are guaranteed power before any of the ports assigned to the other two priority levels. Ports assigned to the other priority levels receive power only if all the Critical ports are receiving power. Ports that are connected to your most critical powered devices should be assigned to this level. If there is not enough power to support all the ports set to the Critical priority level, power is provided to the ports based on port number, in ascending order.

The High level is the second highest level. Ports set to this level receive power only if all the ports set to the Critical level are already receiving power. If there is not enough power to support all of the ports set to the High priority level, power is provided to the ports based on port number, in ascending order.

The lowest priority level is Low. This is the default setting. Ports set to this level only receive power if all of the ports assigned to the other two levels are already receiving power. As with the other levels, if there is not enough power to support all of the ports set to the Low priority level, power is provided to the ports based on port number, in ascending order.

Power allocation is dynamic. Ports supplying power to powered devices may cease power transmission if the switch's power budget is at maximum usage and new powered devices, connected to ports with higher priorities, become active.

Wiring Implementation

The IEEE 802.3af standard defines two methods for delivering DC power over copper cable by a switch to powered devices. These methods are known as Alternatives A and B. They identify the individual wires that carry the DC power within the network cables from the switch to powered devices.

Copper cabling typically consists of eight wires. With 10Base-T and 100Base-TX devices, the wires connected to pins 1, 2, 3, and 6 on the RJ-45 connectors carry the network traffic while the wires connected to pins 4, 5, 7, and 8 are unused. With 1G/2.5G/5G devices, all eight wires are used to carry network data.

It takes four wires to deliver DC power to a powered device. With Alternative A, power is delivered on pins 1, 2, 3, and 6. These are the same pins in 10Base-T and 100Base-TX devices that carry the network data. With Alternative B, power is provided over the spare wires.

The switch supplies power to powered devices on the copper ports using PoE Alternatives A and B as described in Table 6.

Table 6. PoE Alternatives A and B for the Copper Ports

PoE Devices	PoE Alternatives
PoE and PoE+ devices Classes 0 to 4 (Types 1 and 2 up to 30W at switch ports)	Alternative A (MDI-X)
PoE++ devices Classes 5 and 6 (Type 3 up to 60W at switch ports)	Alternative A (MDI-X) plus Alternative B (MDI-x, MDI)
PoE++ devices Classes 7 and 8 (Type 4 up to 75W/90W at switch ports)	Alternative A (MDI-X) plus Alternative B (MDI-x, MDI)

The switch supports PoE powered devices that comply with the IEEE 802.3af, 802.3at, and 802.3bt standards. The standards require that powered devices support both Alternatives A and B.

Note

Legacy Powered Devices that are non-standard or were manufactured before the completion of the standards and support only one method might not be compatible with the switch.

The switch can operate in the following modes:

- Non-PoE mode: All network devices connected to the ports on the switch do not require PoE sourcing.
- PoE mode: Some or all network devices connected to the ports on the switch require PoE sourcing, in accordance with std. IEEE 802.3at Type 1 “PoE.”
- PoE+ mode. Some or all network devices connected to the ports on the switch require PoE sourcing, in accordance with std. IEEE 802.3at Type 1 and/or Type 2 “PoE+.”
- PoE++ mode. Some or all network devices connected to ports that support PoE++ on the switch require PoE sourcing, in accordance with std. IEEE 802.3bt Type 3 4PPoE, and/or Type 3 PoE++.
- PoE++ mode. Some or all network devices connected to ports that support PoE++ on the switch require PoE sourcing, in accordance with std. IEEE 802.3bt Type 4 PoE++.

SFP+ Transceiver Ports

The x240 series switches have two SFP+ transceiver ports.

SFP+ Transceivers

SFP+ transceivers are purchased separately. For a list of supported transceivers, refer to the product data sheet on the Allied Telesis web site.

LEDs

Each transceiver port has one LED. Refer to Figure 11.

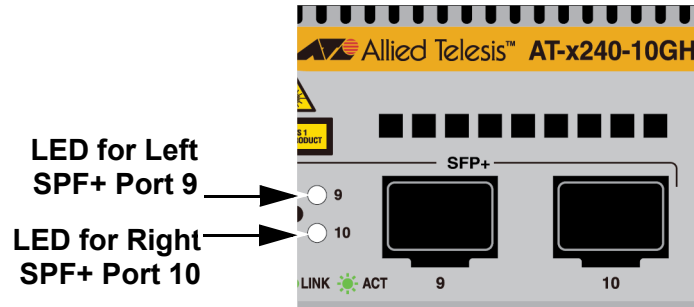

6117

Figure 11. SFP+ Transceiver Ports LEDs

The LED states are described in Table 7.

Table 7. LEDs for the SFP+ Transceiver Ports

State	Description
Solid green	The port has established a link to a network device.
Flashing green	The port is transmitting or receiving packets.
Off	Possible causes of this state are listed here: <ul style="list-style-type: none"> <input type="checkbox"/> The SFP+ transceiver port is empty. <input type="checkbox"/> The SFP+ transceiver has not established a link with another network device. <input type="checkbox"/> The LEDs are turned off. To turn on the LEDs, use the eco-friendly button.

Fault and Power LEDs

The Fault and Power LEDs are shown in Figure 12.

Fault and Power LEDs

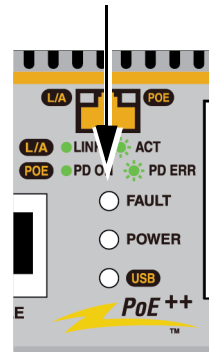

6118

Figure 12. Fault and Power LEDs

Note

The USB LED is described in “USB Port” on page 36.

The states of the LEDs are described in Table 8.

Table 8. Fault and Power LEDs

State	Description
Fault LED	
Off	The switch is operating normally or is not powered on.
Solid Red	The switch is updating its AlliedWare Plus management software.
Flashing Red (Once)	The system or fan is experiencing a problem, such as overheating. To troubleshoot the problem, view the log messages by displaying the system log file with the <code>SHOW LOG</code> command.
Flashing Red (Six times)	The switch is overheating.
Power LED	
Solid Green	The power supply and switch are operating normally.

Table 8. Fault and Power LEDS (Continued)

State	Description
Off	The switch is powered off or the input power is outside the normal operating range.

eco-friendly Button

The eco-friendly button on the front panel of the switch is used to toggle the port LEDs on or off. See Figure 13. You can turn off the LEDs to conserve electricity when you are not using them to monitor the device. You can also toggle the LEDs with the `ECOFRIENDLY LED` and `NO ECOFRIENDLY LED` commands in the Global Configuration mode of the command line interface of the AlliedWare Plus management software.

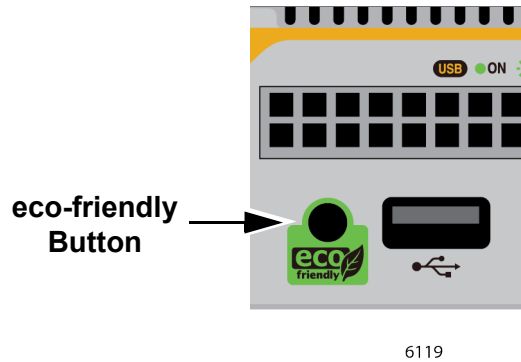

Figure 13. eco-friendly Button

The switch is operating in a low power mode when the LEDs are turned off. The low power mode does not interfere with the network operations of the device.

The management software on the switch has a command that blinks the LEDs so that you can quickly and easily identify a specific unit among the devices in an equipment rack. It is the `FINDME` command. The command works even when the switch is operating in the low power mode, with the port LEDs turned off.

Note

Before checking or troubleshooting network connections to ports on the switch, you should always check to be sure that the LEDs are on by either pressing the eco-friendly button or issuing the `ECOFRIENDLY LED` and `NO ECOFRIENDLY LED` commands in the Global Configuration mode in the command line interface.

USB Port

You can use the USB port on the management panel for the following functions:

- ❑ Store configuration files on flash drives.
- ❑ Restore configuration files to switches whose settings have been lost or corrupted.
- ❑ Configure replacement units by downloading configuration files from a flash drive.
- ❑ Update the AlliedWare Plus management software.

The port is USB 2.0 compatible.

USB Port LED The USB port has one LED, shown in Figure 14.

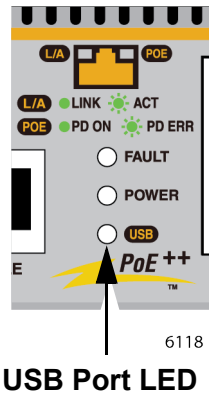

Figure 14. USB Port LED

The states of the LEDs are described in Table 9.

Table 9. USB Port LED

State	Description
Off	The USB slot is empty.
Solid green	A USB drive is inserted in the slot.
Flashing green	The switch is writing data to or reading data from the USB drive.
Flashing amber	The switch is experiencing problems writing data to or reading data from the USB drive.

Console Port

The Console port is used to manage the switch with the command line interface in the AlliedWare Plus management software. Managing the switch through the Console port is referred to as local management because you have to be at the physical location of the switch. This type of management is not conducted over the network.

The Console port has these default settings:

- Default baud rate: 9600 bps (The baud rates of the port are 9600, 19200, 38400, 57600, and 115200 bps.)
- Data bits: 8
- Parity: None
- Stop bits: 1
- Flow control: None

Note

These settings are for a DEC VT100 or ANSI terminal, or an equivalent terminal emulation program.

Here are the guidelines for local management through the Console port:

- Local management requires a terminal, computer, or laptop with an RS-232 serial port or USB port.
- A terminal emulator, such as PuTTY, is also required.
- If your computer has an RS-232 port, you will need a management cable with DB-9 and RJ-45 connectors. Refer to Appendix A for the Console port pinouts.
- If your computer has a USB port, you may need to purchase a USB-to-Serial converter that is compatible with its operating system. An example is the VT-Kit3 converter from Allied Telesis, shown in Figure 15. The VT-Kit3 converter is sold separately.



Figure 15. VT-Kit3 Management Cable

- ❑ Local management sessions do not interfere with the network operations of the switch.
- ❑ The switch does not need an IP address for local management sessions.

Power Supply and Fan

The x240 series switches come with pre-installed power supply and fan.

Power Supply

The x240 series switches come with one pre-installed power supply unit that supplies system power.

For the x240-10GHXm and x240-26GHXm switches, PoE++ power is also supplied. See “Input Voltages” on page 124 for the input voltage ranges. A power cord and retaining clip are included with the switch.



Warning

Power cord is used as a disconnection device. To de-energize equipment, disconnect the power cord. ⚡ E3

Note

The power supply and fan are not field-replaceable.

Fan The x240 series switches have one or two fans pre-installed on the back panel. For the number of fans pre-installed, see Table 10.

Table 10. Fan in the x240 Series Switches

	Number of Fans
x240-10GHXm	1
x240-10GTXm	1
x240-26GHXm	2
x240-26GTXm	2

Here are notes for the fans:

- Fans are not field-replaceable.
- The airflow direction is from front to back, with the fan drawing air out of the switch.
- Problems with the fan are displayed with the Fault LED. See “Fault and Power LEDs” on page 33.

Chapter 2

Beginning the Installation

The chapter contains the following sections:

- “Reviewing Safety Precautions” on page 42
- “Choosing a Site for the Switch” on page 46
- “Unpacking the x240-10GHXm or x240-10GTXm Switch” on page 47
- “Unpacking the x240-26GHXm or x240-26GTXm Switch” on page 48
- “x240-10GHXm and x240-10GTXm Installation Options” on page 49
- “x240-26GHXm and x240-26GTXm Installation Options” on page 50
- “Accessory Hardware” on page 51
- “Recording the Serial Number and MAC Address” on page 53

Reviewing Safety Precautions

Please review the following safety precautions before beginning the installation procedure.

Note

Safety statements that have the  symbol are translated into multiple languages in the *Translated Safety Statements* document at www.alliedtelesis.com/support.



Warning

Class 1 Laser product.  L1



Warning

Laser Radiation.
Class 1M Laser product.



Warning

Do not stare into the laser beam.  L2



Warning

Do not look directly at the fiber optic ends or inspect the cable ends with an optical lens.  L6



Warning

To prevent electric shock, do not remove the cover. No user-serviceable parts inside. This unit contains hazardous voltages and should only be opened by a trained and qualified technician. To avoid the possibility of electric shock, disconnect electric power to the product before connecting or disconnecting the LAN cables.  E1



Warning

Do not work on equipment or cables during periods of lightning activity.  E2

**Warning**

Power cord is used as a disconnection device. To de-energize equipment, disconnect the power cord. ⚡ E3

**Warning**

Class I Equipment. This equipment must be earthed. The power plug must be connected to a properly wired earth ground socket outlet. An improperly wired socket outlet could place hazardous voltages on accessible metal parts. ⚡ E4

Note

Pluggable Equipment. The socket outlet shall be installed near the equipment and shall be easily accessible. ⚡ E5

**Caution**

Air vents must not be blocked and must have free access to the room ambient air for cooling. ⚡ E6

**Warning**

Operating Temperatures. This product is designed for a maximum ambient temperature of 50° degrees C. ⚡ E52

Note

All Countries: Install product in accordance with local and National Electrical Codes. ⚡ E8

**Warning**

Only trained and qualified personnel are allowed to install or replace this equipment. ⚡ E14

**Caution**

Circuit Overloading: Consideration should be given to the connection of the equipment to the supply circuit and the effect that overloading of circuits might have on overcurrent protection and supply wiring. Appropriate consideration of equipment nameplate ratings should be used when addressing this concern. ⚡ E21



Caution

Risk of explosion if battery is replaced by an incorrect type. Replace only with the same or equivalent type recommended by the manufacturer. Dispose of used batteries according to the manufacturer's instructions.

Attention: Le remplacement de la batterie par une batterie de type incorrect peut provoquer un danger d'explosion. La remplacer uniquement par une batterie du même type ou de type équivalent recommandée par le constructeur. Les batteries doivent être éliminées conformément aux instructions du constructeur.  E22



Warning

Mounting of the equipment in the rack should be such that a hazardous condition is not created due to uneven mechanical loading.  E25



Warning

The chassis may be heavy and awkward to lift. Allied Telesis recommends that you get assistance when mounting the chassis in an equipment rack.  E28

Note

Use dedicated power circuits or power conditioners to supply reliable electrical power to the device.  E27



Warning

This unit might have more than one power cord. To reduce the risk of electric shock, disconnect all power cords before servicing the unit.  E30

Note

If installed in a closed or multi-unit rack assembly, the operating ambient temperature of the rack environment may be greater than the room ambient temperature. Therefore, consideration should be given to installing the equipment in an environment compatible with the manufacturer's maximum rated ambient temperature (T_{mra}).  E35

**Caution**

Installation of the equipment in a rack should be such that the amount of air flow required for safe operation of the equipment is not compromised.  E36

**Warning**

Reliable earthing of rack-mounted equipment should be maintained. Particular attention should be given to supply connections other than direct connections to the branch circuits (e.g., use of power strips).  E37

**Warning**

To reduce the risk of electric shock, the PoE ports on this product must not connect to cabling that is routed outside the building where this device is located.  E40

**Caution**

An Energy Hazard exists inside this equipment. Do not insert hands or tools into open chassis slots or plugs.  E44

**Caution**

The unit does not contain serviceable components. Please return damaged units for servicing.  E42

**Warning**

The temperature of an operational SFP or SFP+ transceiver may exceed 70° C (158° F). Exercise caution when removing or handling a transceiver with unprotected hands.  E43

Choosing a Site for the Switch

Observe these requirements when planning the installation of the switch.

- ❑ Before installing the switch in an equipment rack, check that the rack is safely secured so that it will not tip over. Devices in a rack should be installed starting at the bottom, with the heavier devices near the bottom of the rack.
- ❑ Before installing the switch on a table, check that the table is level and stable.
- ❑ The power outlet should be located near the switch and be easily accessible.
- ❑ The site should allow for easy access to the ports on the front of the switch, so that you can easily connect and disconnect cables, and view the port LEDs.
- ❑ The site should allow for adequate air flow around the unit and through the cooling vents on the front and rear panels. (The ventilation direction is from front to back.)
- ❑ The site should not expose the switch to moisture or water.
- ❑ The site should be a dust-free environment.
- ❑ The site should include dedicated power circuits or power conditioners to supply reliable electrical power to the network devices.
- ❑ Do not install the switch in a wiring or utility box because it might overheat and fail from inadequate airflow.



Warning

Switches should not be stacked on a table or desktop. They could present a physical safety hazard if you need to move or replace switches. ⚡ E91

Unpacking the x240-10GHXm or x240-10GTXm Switch

The shipping contents of the x240-10GHXm or x240-10GTXm switch are shown in Figure 16. Verify and inspect the contents. If any item is missing or damaged, contact your Allied Telesis sales representative for assistance.

Note

You should retain the original packaging material in case you need to return the unit to Allied Telesis.

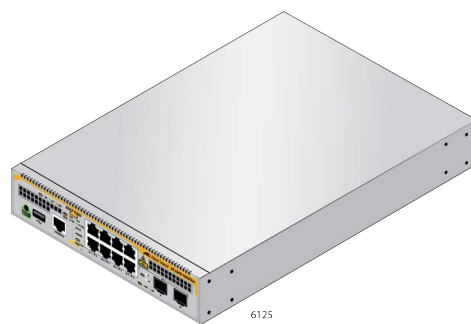

One x240-10GHXm or
x240-10GTXm switch



One regional AC power cord



Power cord retaining clip

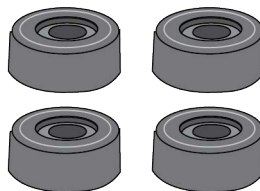

Four bumper feet

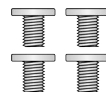

Four M3x6mm bumper feet screws

Figure 16. Contents of the x240-10GHXm and x240-10GTXm Switches

Unpacking the x240-26GHXm or x240-26GTXm Switch

The shipping contents of the x240-26GHXm or x240-26GTXm switch are shown in Figure 17. Verify and inspect the contents. If any item is missing or damaged, contact your Allied Telesis sales representative for assistance.

Note

You should retain the original packaging material in case you need to return the unit to Allied Telesis.

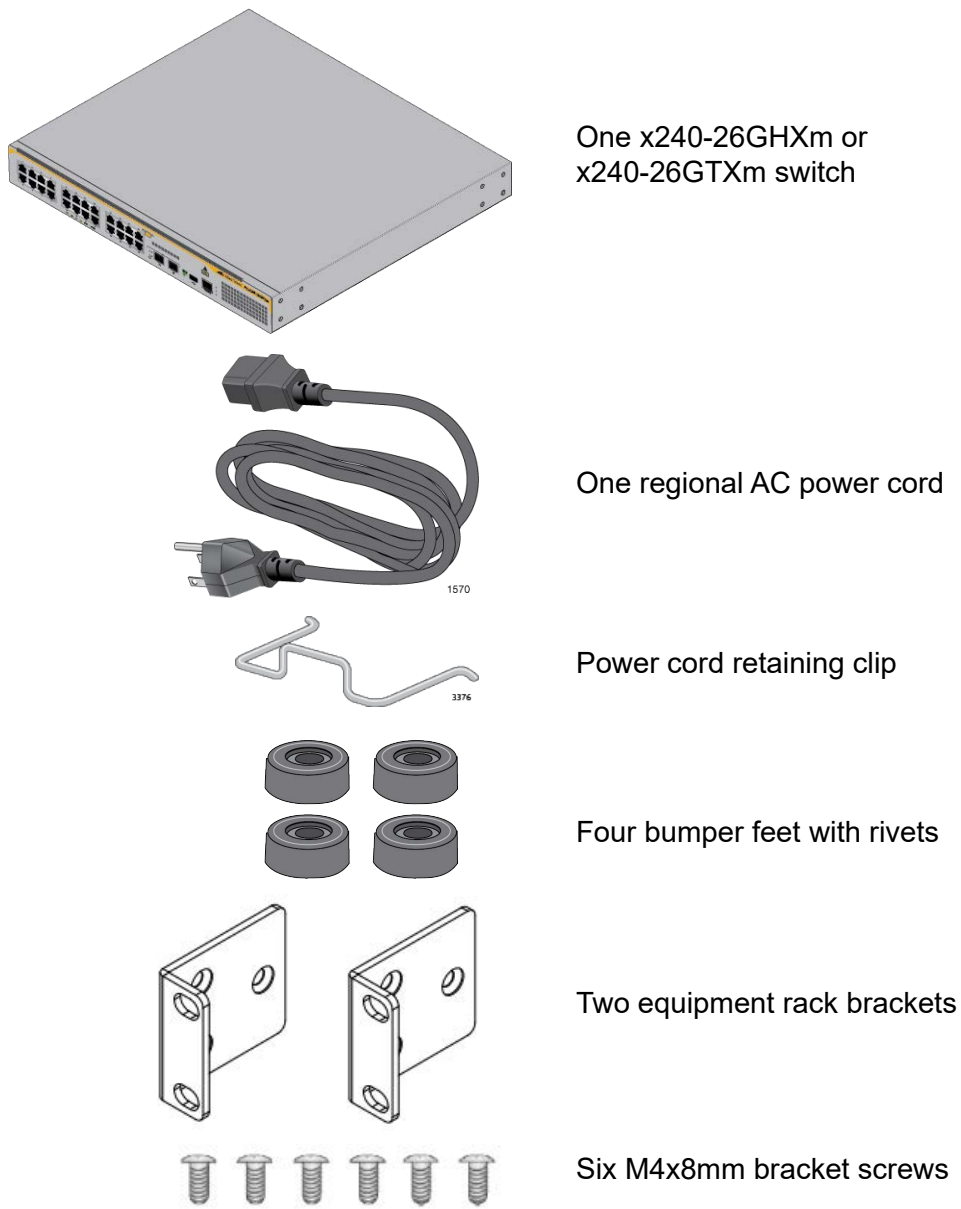

Figure 17. Contents of the x240-26GHXm and x240-26GTXm Switches

x240-10GHXm and x240-10GTXm Installation Options

Figure 18 illustrates the installation options for the x240-10GHXm and x240-10GTXm switches.



Table or desktop with the bumper feet included with switch.

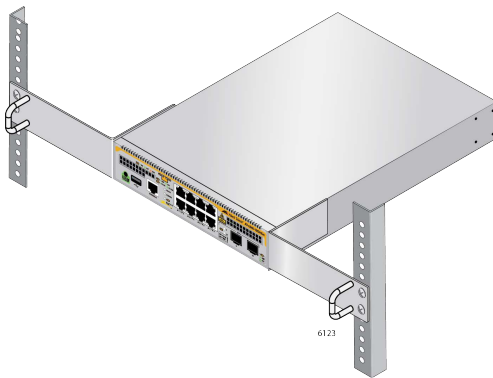

Standard 19-inch equipment rack with the RKMT-J14 equipment rack brackets kit. Kit sold separately.



Standard 19-inch equipment rack with the RKMT-J15 equipment rack brackets kit. Kit sold separately.



Wall installation with the BRKT-J24 wall brackets kit. Kit sold separately.

Figure 18. Installation Options for the x240-10GHXm and x240-10GTXm Switches

x240-26GHXm and x240-26GTXm Installation Options

Figure 19 illustrates the installation options for the x240-26GHXm and x240-26GTXm switches.

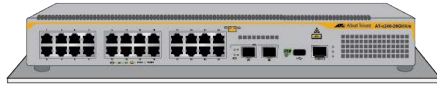
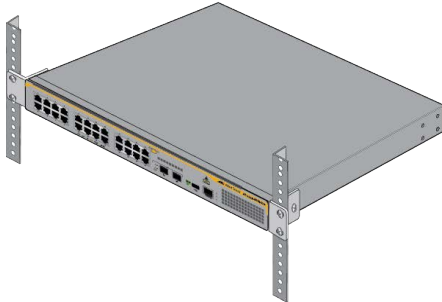
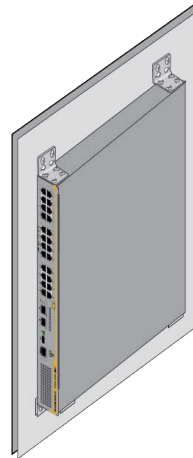

Table or desktop with the bumper feet included with switch.



Standard 19-inch equipment rack brackets included with switch.



Wall installation with BRKT-J24 wall brackets kit. Kit sold separately.

Figure 19. Installation Options for the x240-26GHXm and x240-26GTXm Switches

Accessory Hardware

Figure 20 shows the items in the BRKT-J24 wall brackets accessory kit.

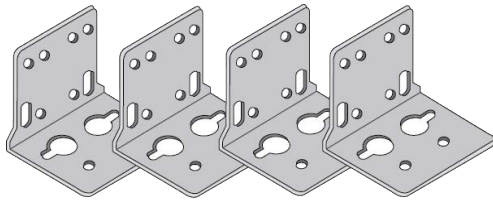

Four BRKT-J24 wall-mounting brackets



Sixteen truss head screws for attaching the BRKT-J24 wall brackets to the switch.
Length: 6.0mm (0.2 in.)
Diameter: 4.0mm (0.2 in.)

Figure 20. BRKT-J24 Accessory Kit (Optional)

Figure 21 shows the items in the RKMT-J14 accessory kit.

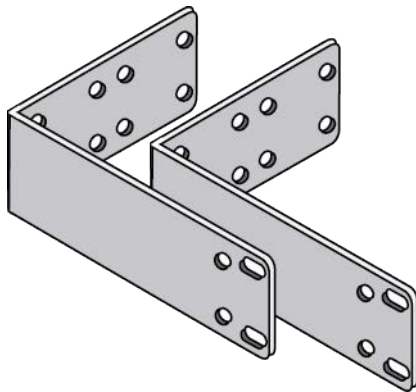

Two RKMT-J14 equipment rack brackets

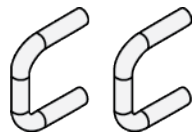

Two handles for the RKMT-J14 equipment rack brackets



Four Phillips pan head screws for attaching the handles to the RKMT-J14 equipment rack brackets:
Length: 6.0mm (0.2 in.)
Diameter: 3.0mm (0.1 in.)



Eight truss head screws for attaching the brackets to the switch:
Length: 6.0mm (0.2 in.)
Diameter: 4.0mm (0.1 in.)

Figure 21. RKMT-J14 Accessory Kit (Optional)

Figure 22 shows the items in the RKMT-J15 accessory kit.

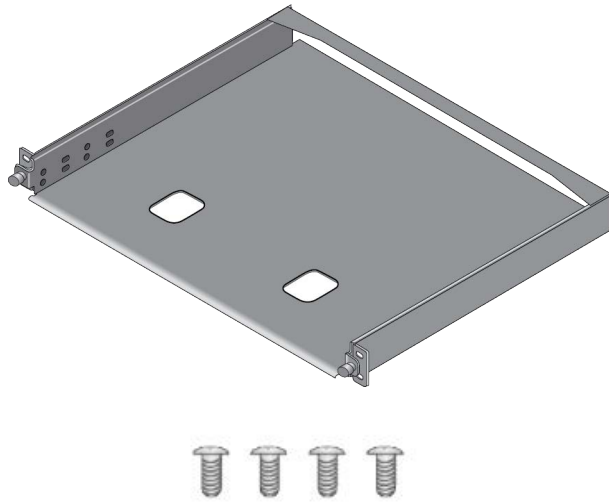

RKMT-J15 Tray to hold switch(es) in an equipment rack

Four truss head screws for attaching the switches to the tray:
Length: 6.0mm (0.2 in.)
Diameter: 4.0mm (0.1 in.)

Figure 22. RKMT-J15 Accessory Kit (Optional)

Recording the Serial Number and MAC Address

The serial number and MAC address of the switch are located on labels on the bottom panel. Refer to Figure 23. If you need to record the numbers for your records, you should do so before installing the device.

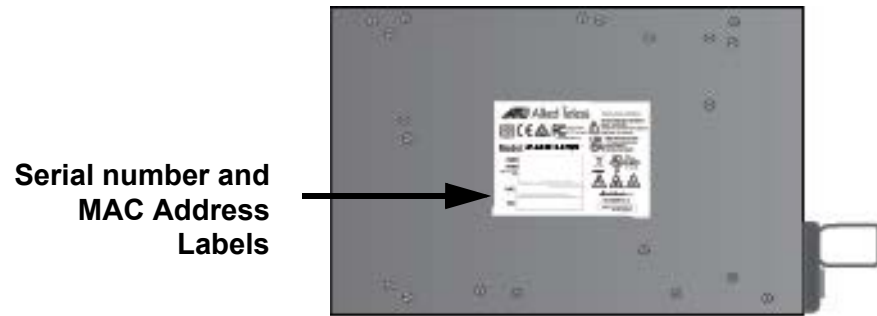

Figure 23. Serial Number and MAC Address Labels

Note

You can also view the serial number and MAC address of the switch with the `SHOW SYSTEM SERIALNUMBER` and `SHOW SYSTEM MAC` commands in the User Exec and Privileged EXEC modes of the AlliedWare Plus management software.

Chapter 3

Installing the Switch on a Table or Desktop

This chapter contains the instructions for installing the switch on a table or desktop.



Warning

Switches should not be stacked on a table or desktop. They could present a physical safety hazard if you need to move or replace switches. *ES* E91

To install the chassis on a table, perform the following procedure:

1. Review the procedure in “Choosing a Site for the Switch” on page 46 to verify that the selected site is suitable for the unit.
2. Verify that the table is strong enough to support the weight of the switch.
3. Verify that the accessory kit came with all the appropriate items. Refer to Figure 16 on page 47.
4. Lift the chassis from the shipping box and place it upside down on a table.
5. Attach the four bumper feet to the bottom corners of the switch using the four M3x6mm screws and a cross-head screwdriver. See Figure 24 on page 56.

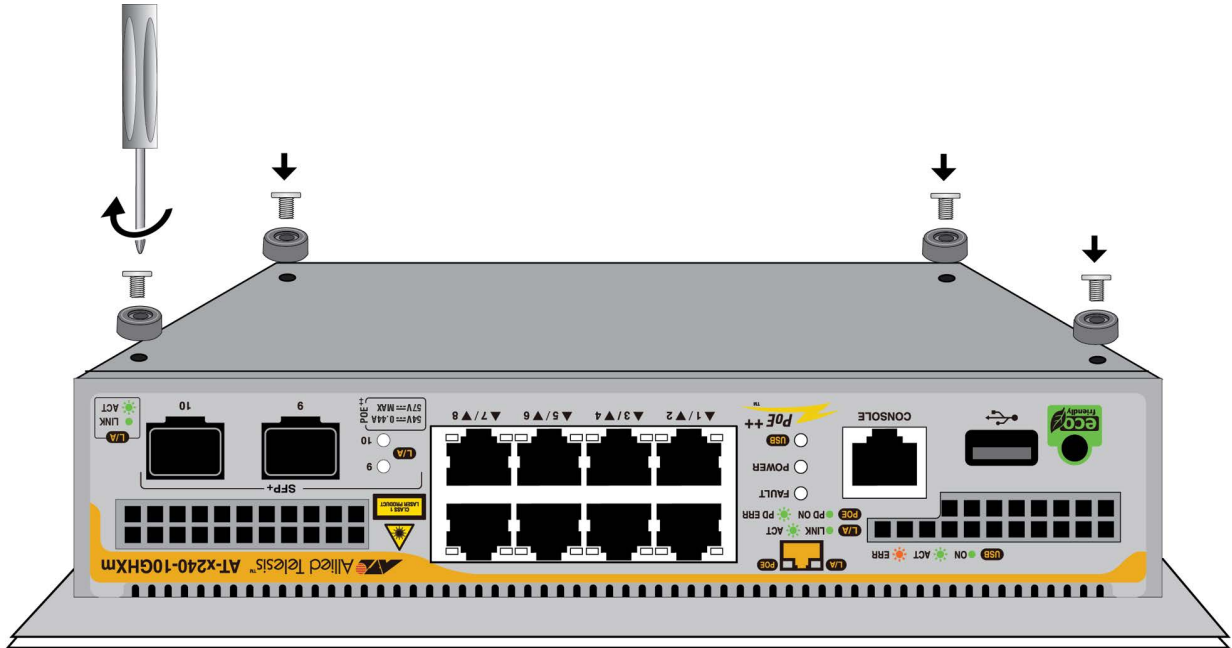

Figure 24. Attaching the Bumper Feet

6. Turn the switch upright and place it on a flat, secure desk or table, leaving ample space around it for ventilation.
7. Go to Chapter 6, “Cabling the Networking Ports” on page 85.

Chapter 4

Installing the Switch in an Equipment Rack

This chapter contains the instructions for installing the switch in an equipment rack. The procedures in this chapter are listed here:

- ❑ “Overview of Installing the Switch in an Equipment Rack” on page 58
- ❑ “Installing the x240-10GHXm and x240-10GTXm Switches in an Equipment Rack with the RKMT-J14 Brackets” on page 60
- ❑ “Installing the x240-10GHXm and x240-10GTXm Switches in an Equipment Rack with the RKMT-J15 Bracket” on page 65
- ❑ “Installing the x240-26GHXm or x240-26GTXm Switch in an Equipment Rack” on page 71

Overview of Installing the Switch in an Equipment Rack

x240-10GHXm and x240-10GTXm Switches

You can install the x240-10GHXm and x240-10GTXm switches in a 19-inch equipment rack two ways. One way is with the RKMT-J14 brackets kit. The kit is sold separately. Refer to Figure 25.

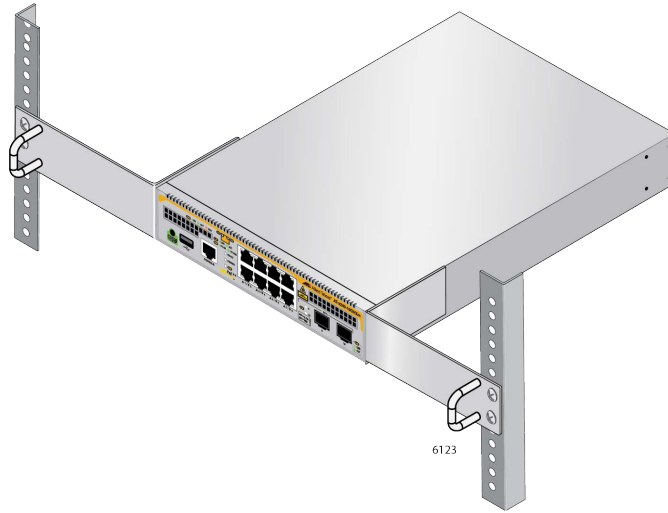

Figure 25. RKMT-J14 Brackets and for the x240-10GHXm and x240-10GTXm Switches

For installation instructions, refer to “Installing the x240-10GHXm and x240-10GTXm Switches in an Equipment Rack with the RKMT-J14 Brackets” on page 60.

You can also install the x240-10GHXm and x240-10GTXm Switches in an equipment rack with the RKMT-J15 bracket. The kit is sold separately. Refer to Figure 26.

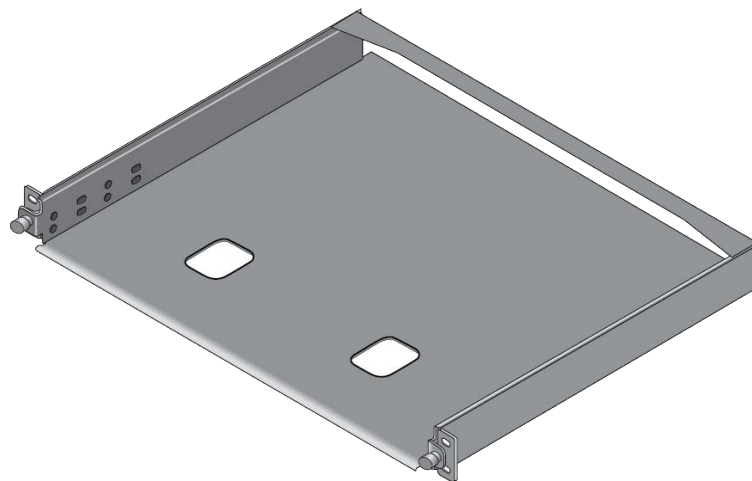

Figure 26. RKMT-J15 Bracket

The bracket lets you install two switches side-by-side. Refer to Figure 27.



Figure 27. RKMT-J14 Bracket with Switches

For installation instructions refer, to “Installing the x240-10GHXm and x240-10GTXm Switches in an Equipment Rack with the RKMT-J15 Bracket” on page 65.

x240-26GHXm and x240-26GTXm Switches

You can install the x240-26GHXm and x240-26GTXm switches in a 19-inch equipment rack with the two brackets included with the switch. See Figure 28 as an example.

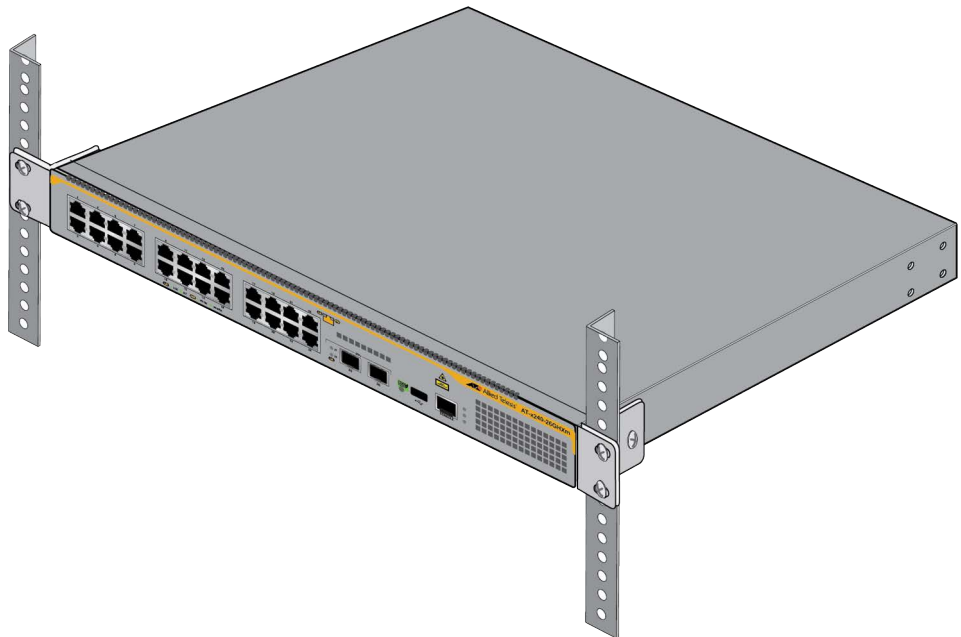

Figure 28. x240-26GHXm Switch in an Equipment Rack

Installing the x240-10GHXm and x240-10GTXm Switches in an Equipment Rack with the RKMT-J14 Brackets

This section contains the procedure for installing the switch in a standard 19-inch equipment rack, with the RKMT-J14 Brackets.

Required Items

The following items are required to install the switch in an equipment rack with the RKMT-J14 Bracket:

- One RKMT-J14 Brackets kit. Refer to Figure 21 on page 51 for the kit contents.
- Cross-head screwdriver (not provided)
- Four standard equipment rack screws (not provided)

Switch Orientations in the Equipment Rack

The switch has two sets of four screw holes on the left and right sides, for attaching the RKMT-J14 Brackets. Refer to Figure 29.

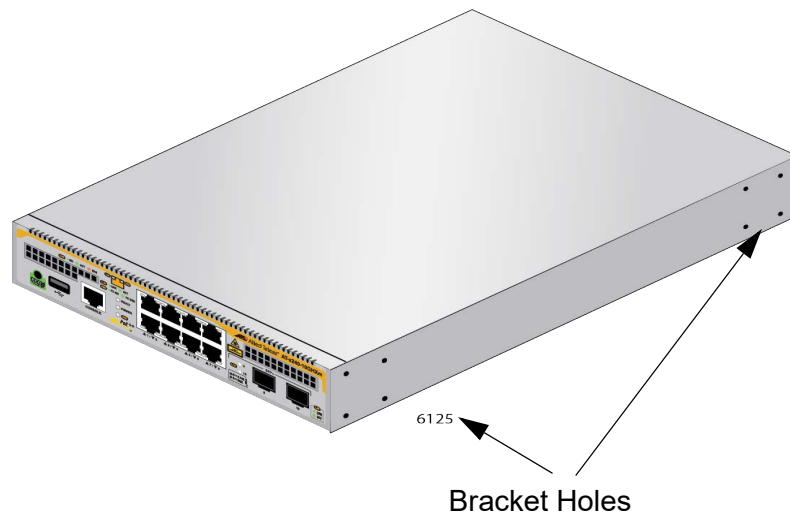

Figure 29. Bracket Holes

The brackets also have two sets of four holes. Refer to Figure 30 on page 61.

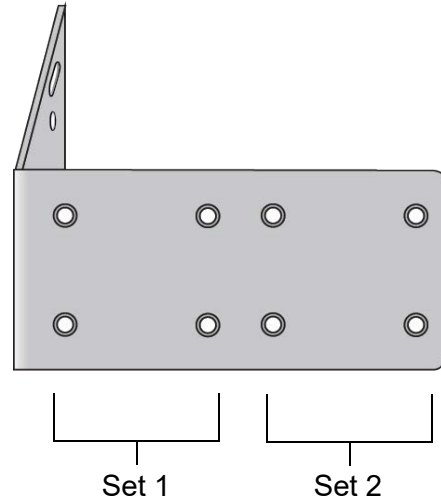

Figure 30. RKMT-J14 Bracket Holes

You can use the different sets of holes on the switch and brackets to install the switch in the equipment rack in a variety of orientations. You can install it with the front panel flush with, extending in front of, or recessed behind the front of the equipment rack. The illustrations in Figure 31 show the switch orientations with the front panel facing the front of the equipment rack.

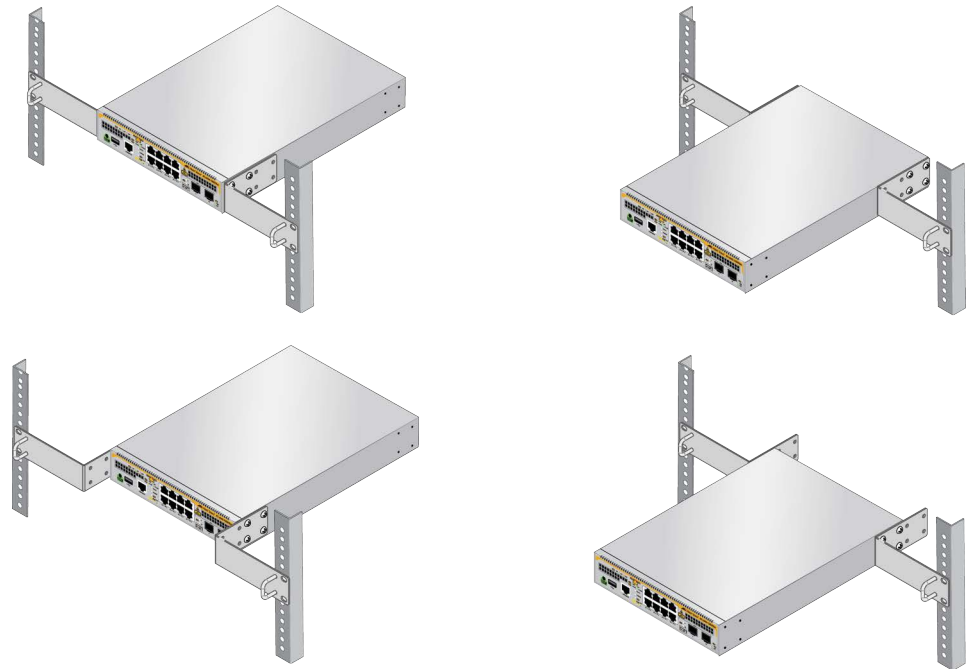

Figure 31. Switch Orientations with the Front Panel Facing the Front of the Equipment Rack

You can also orient the switch with the rear panel facing the front of the equipment rack. Refer to Figure 32.

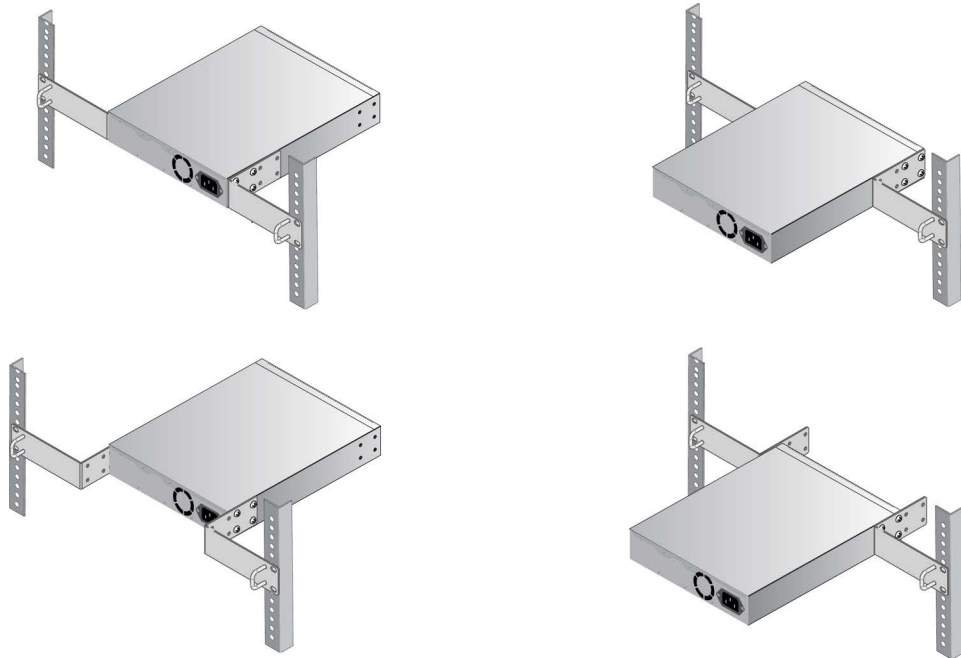

Figure 32. Switch Orientations with the Rear Panel Facing the Front of the Equipment Rack

Installing the Switch

If you have not chosen an orientation for the switch in the equipment rack, review “Switch Orientations in the Equipment Rack” on page 60.

Please review the installation guidelines in “Reviewing Safety Precautions” on page 42 and “Choosing a Site for the Switch” on page 46 before installing the switch in an equipment rack.



Caution

The chassis may be heavy and awkward to lift. Allied Telesis recommends that you get assistance when mounting the chassis in an equipment rack. *E28*

To install the switch in a 19-inch equipment rack with the RKMT-J14 Brackets, perform the following procedure:

1. Attach the two handles to the RKMT-J14 Brackets using the four M3x6mm screws included in the brackets kit. Refer to Figure 33 on page 63. Attaching the handles is optional.

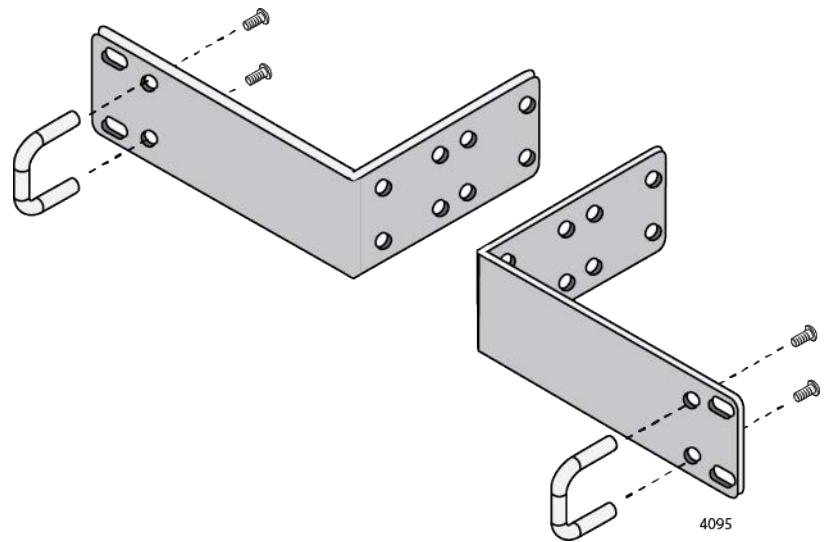

Figure 33. Attaching the Handles to the RKMT-J14 Brackets

2. Place the switch on a level, secure surface.
3. Attach the two brackets to the sides of the switch in the selected position, using the eight M4x6mm screws included in the bracket kit. (Refer to Figure 31 on page 61 and Figure 32 on page 62.) The illustration in Figure 34 shows the installation of the brackets such that the front panel of the switch is even with the front of the equipment rack.

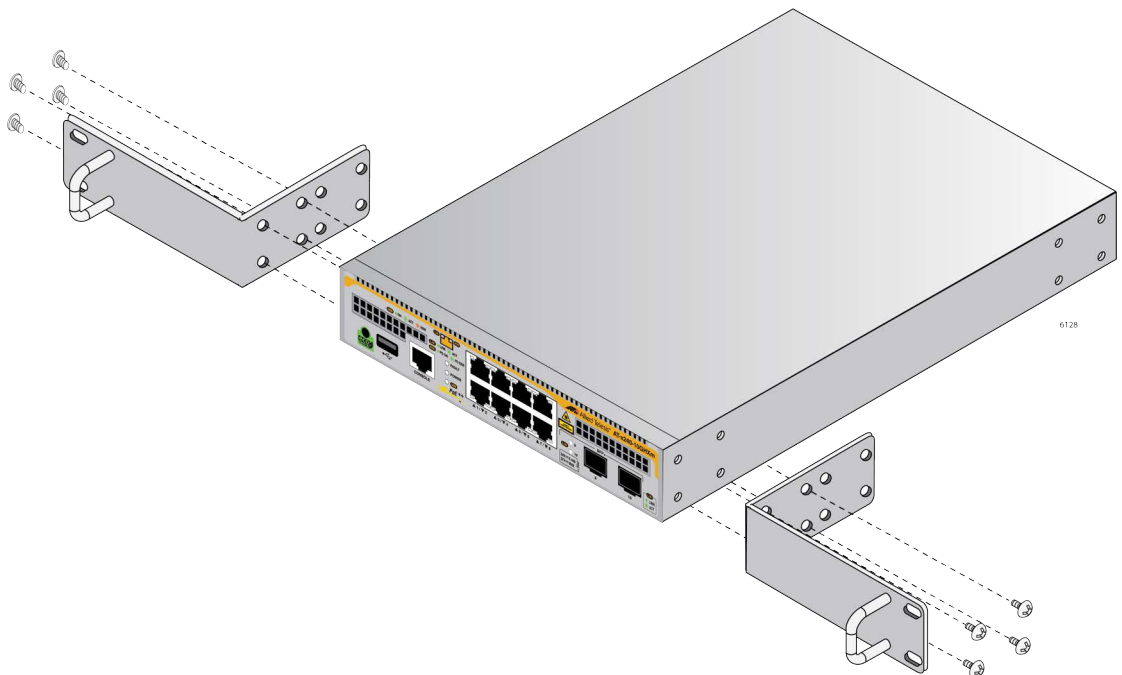

Figure 34. Attaching the RKMT-J14 Brackets to the x240-10GHXm and x240-10GTXm Switches

4. Have another person hold the switch at the desired location in the equipment rack while you secure it using four standard equipment rack screws (not provided). Refer to Figure 35.

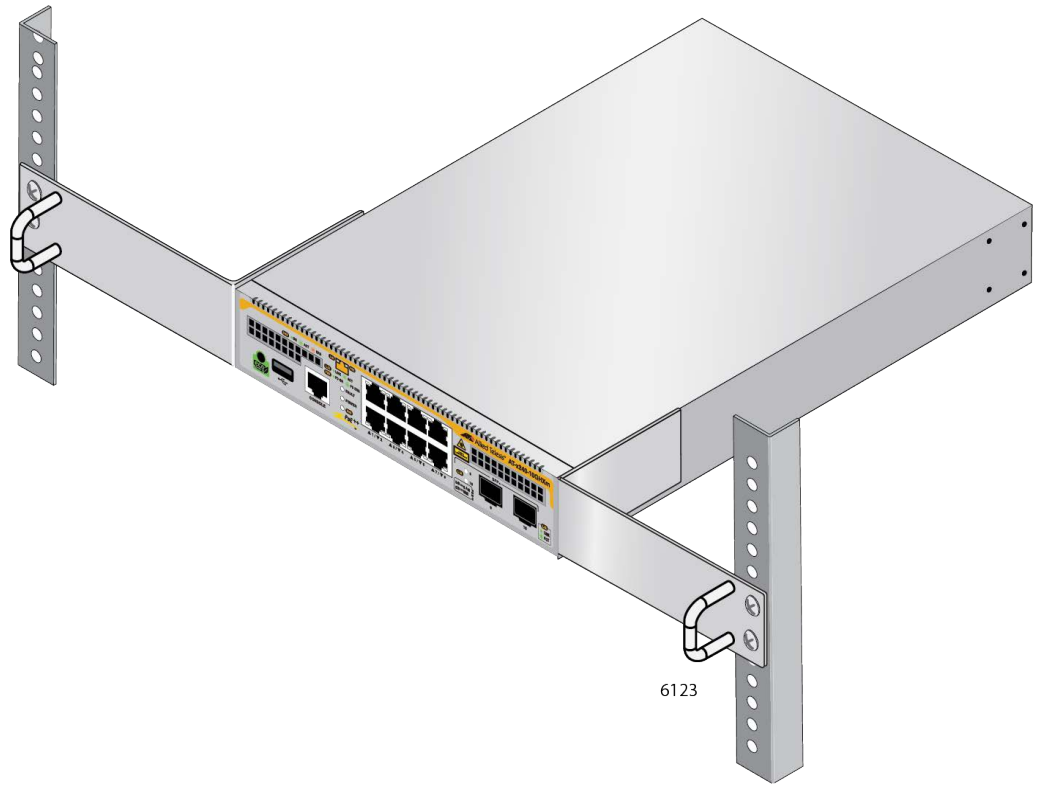

Figure 35. Installing the x240-10GHXm or x240-10GTXm Switch in a Rack with the RKMT-J14 Brackets

5. Go to Chapter 6, “Cabling the Networking Ports” on page 85.

Installing the x240-10GHXm and x240-10GTXm Switches in an Equipment Rack with the RKMT-J15 Bracket

This section contains the procedure for installing the switch in a standard 19-inch equipment rack, with the optional RKMT-J15 Bracket.

Required Items The following items are required to install the switch in an equipment rack with the RKMT-J15 Bracket:

- One RKMT-J15 equipment rack bracket kit. Refer to “RKMT-J15 Accessory Kit (Optional)” on page 52 for the kit contents. (RKMT-J15 kit sold separately)
- Cross-head screwdriver (not provided)
- Four standard equipment rack screws (not provided)

Installing the Switch To install the switch in a 19-inch equipment rack with the RKMT-J15 Bracket, perform the following procedure:

1. Have another person hold the RKMT-J15 Bracket at the desired location in the equipment rack while you secure it using four standard equipment rack screws (not provided). Refer to Figure 36.

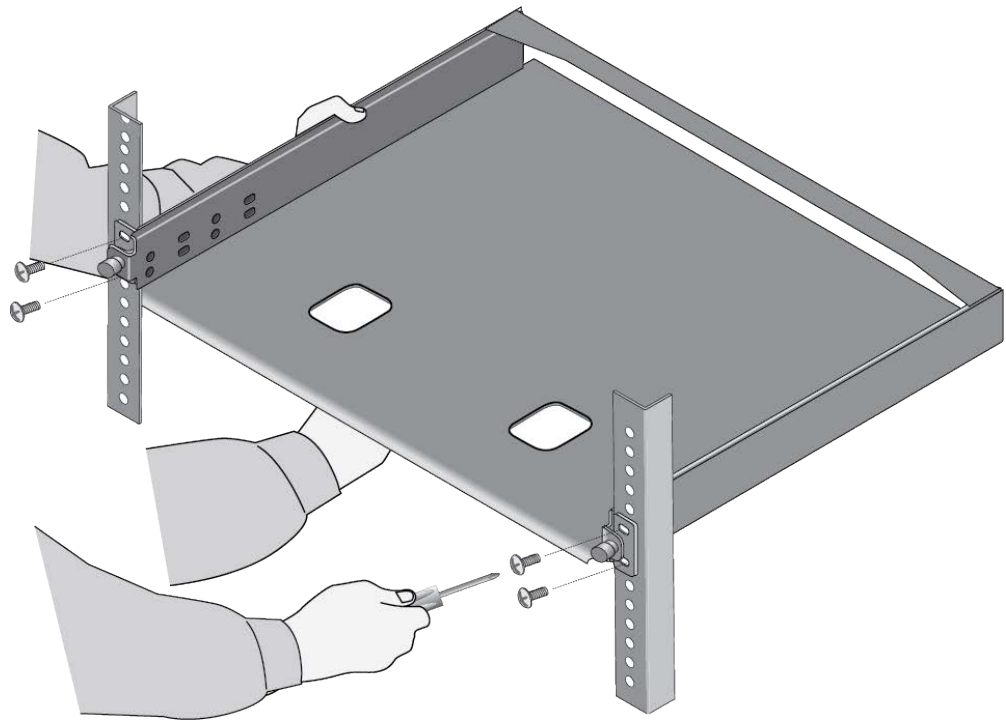

Figure 36. Installing the RKMT-J15 Bracket in the Equipment Rack

2. Loosen the two thumbscrews on the front of the bracket. Refer to Figure 37 on page 66.

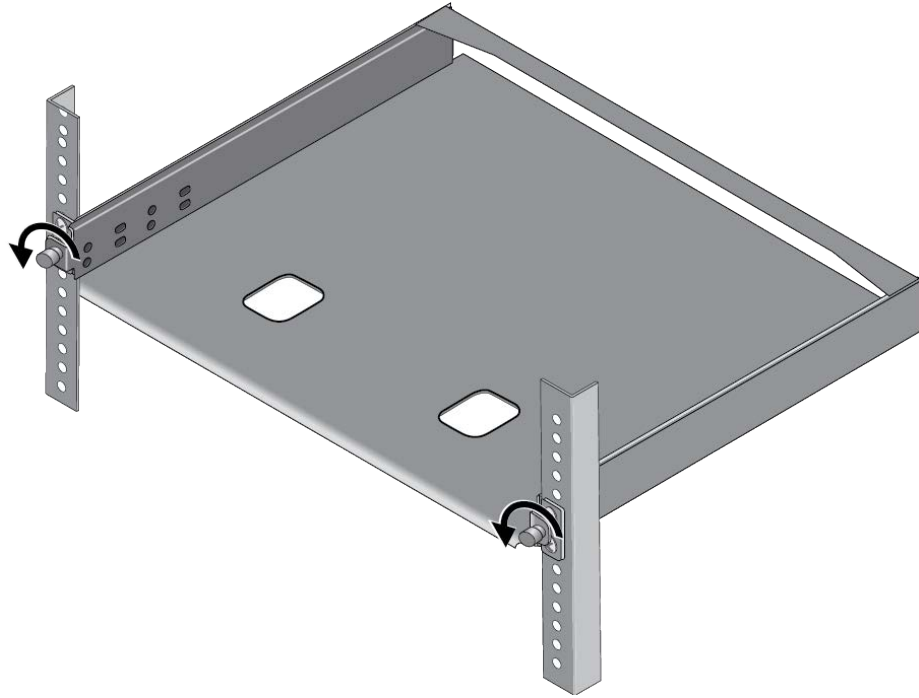

Figure 37. Loosening the Two Thumbscrews on the Front of the RKMT-J15 Bracket

3. Slide out the bracket tray. Refer to Figure 38.

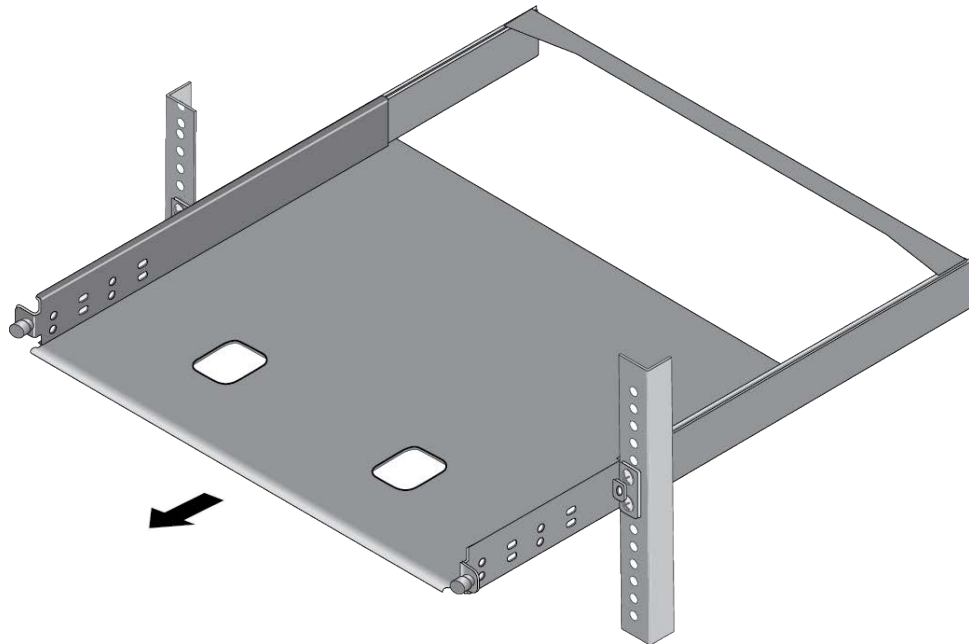

Figure 38. Sliding Out the Tray from the RKMT-J15 Bracket

Note

Perform steps 4 to 6 if the bumper feet are attached to the bottom of the switch. Otherwise go to step 7.

4. Place the switch upside-down on a table.
5. Use a cross-head screwdriver to remove the bumper feet from the switch. Refer to Figure 39.

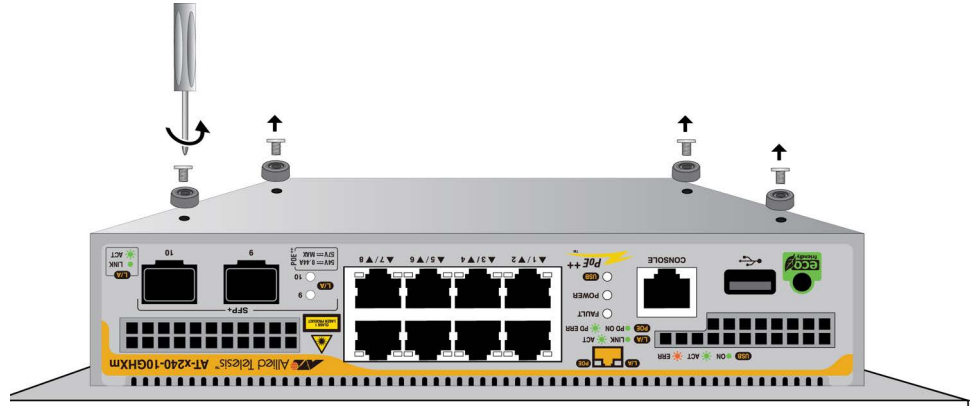

Figure 39. Removing the Bumper Feet from the Bottom Panel of the Switch

6. Turn the switch over so that it is right-side up.
7. Place the switch in the left or right side of the bracket, with its front panel facing the front of the bracket. If you are installing only one switch, you can install it on either the left or right side. Refer to Figure 40 on page 68.

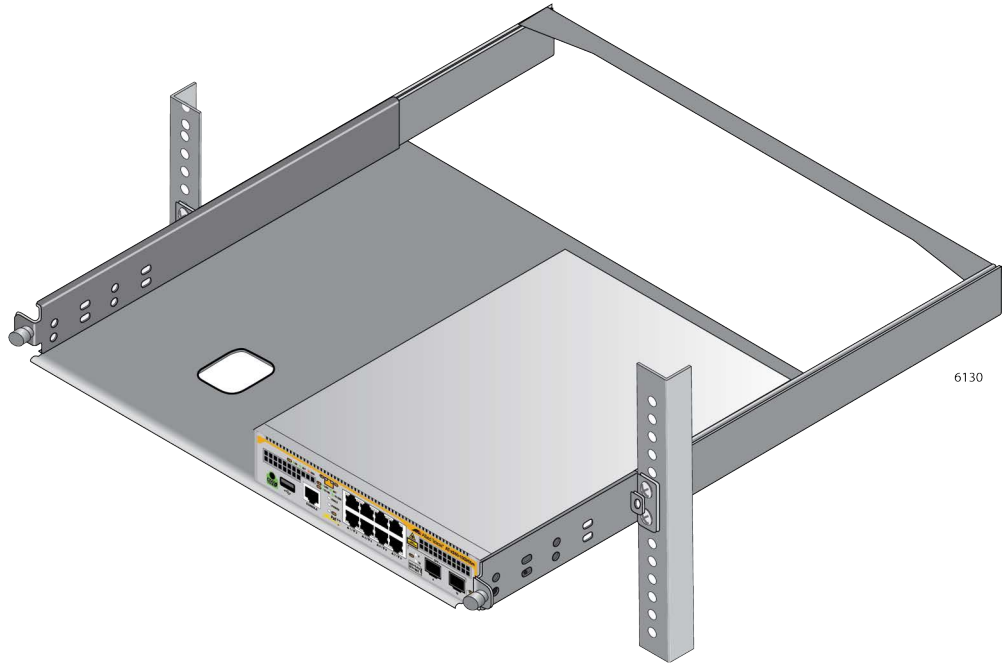

Figure 40. Placing a Switch in the RKMT-J15 Bracket

8. Install two M4x6mm screws included with the RKMT-J15 Bracket to secure the switch to the bracket. Refer to Figure 41.

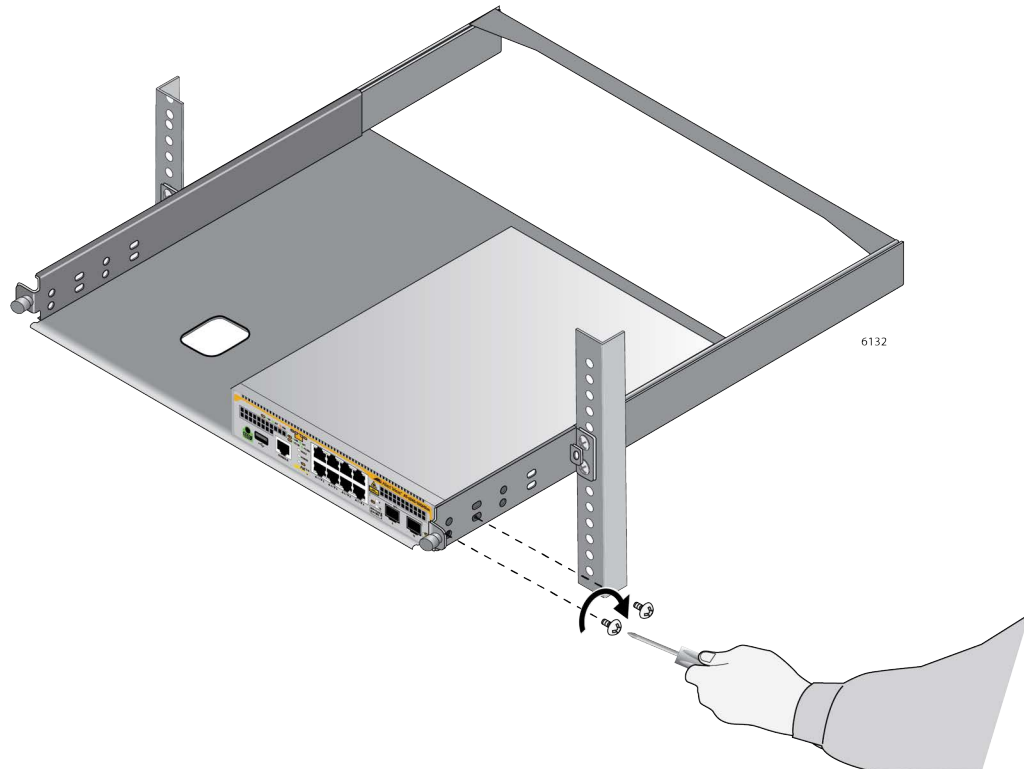

Figure 41. Securing the Switch to the RKMT-J15 Bracket

9. To install a second switch in the bracket, repeat steps 4 to 8.
10. Slide in the bracket tray. Refer to Figure 42.

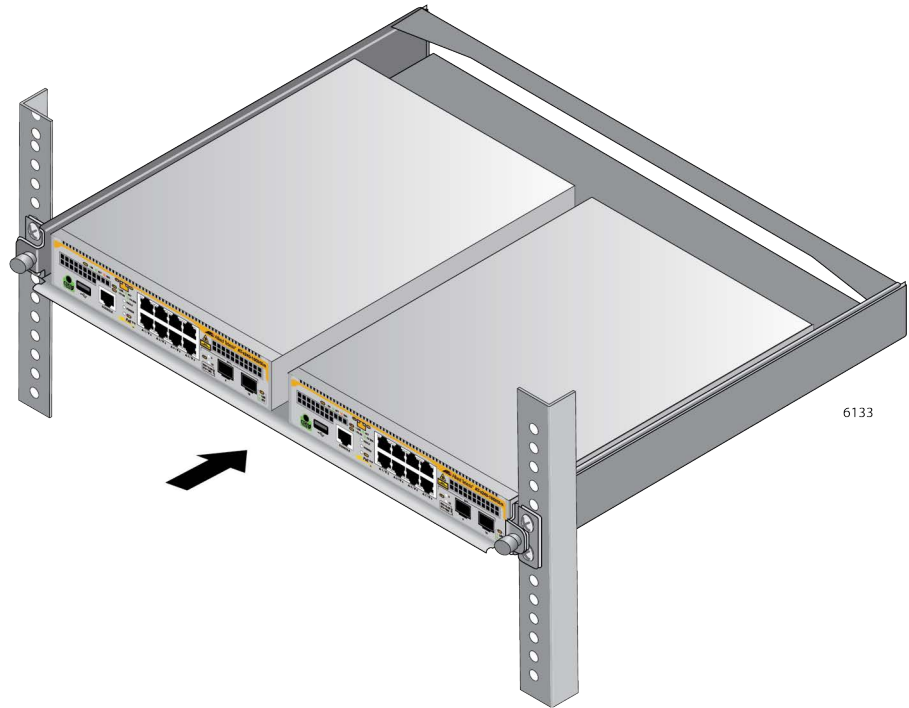

Figure 42. Sliding in the RKMT-J15 Bracket Tray

11. Tighten the two thumbscrews to secure the tray to the equipment rack. Refer to Figure 43 on page 70.

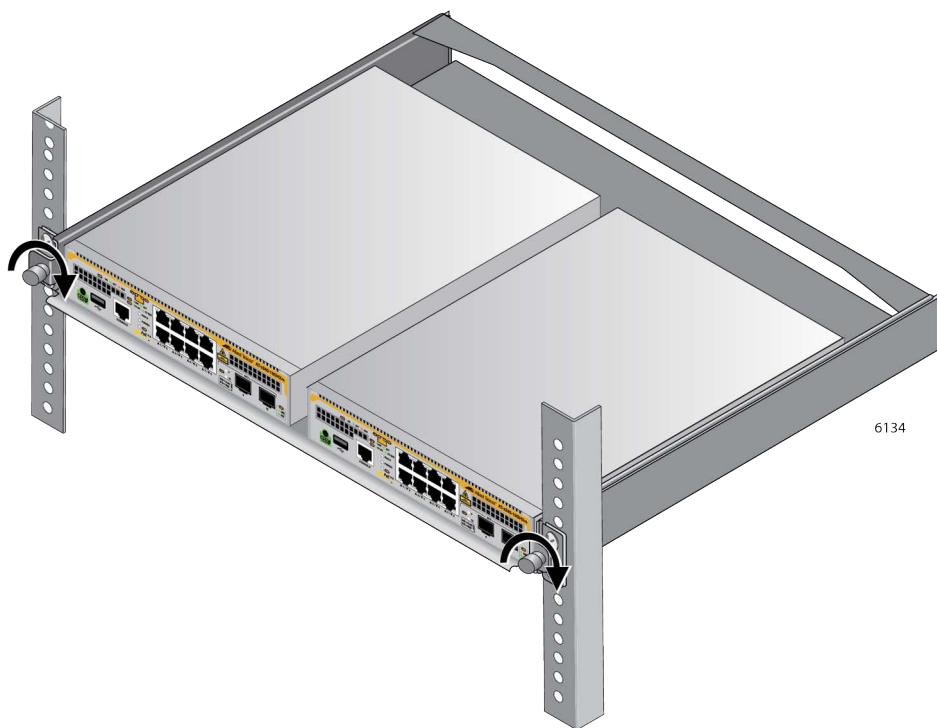

Figure 43. Tightening the Two Thumbscrews on the RKMT-J15 Bracket

12. Go to Chapter 6, “Cabling the Networking Ports” on page 85.

Installing the x240-26GHXm or x240-26GTXm Switch in an Equipment Rack

This section contains the procedure for installing the switch in a standard 19-inch equipment rack using the brackets supplied with the unit.

Required Items The following items are required to install the switch in an equipment rack:

- Two equipment rack brackets and six M4x8mm bracket screws in the accessory kit included with the switch
- Cross-head screwdriver (not provided)
- Four standard equipment rack screws (not provided)

Switch in the Equipment Rack

The x240-26GHXm and x240-26GTXm switches must be installed in the equipment rack with the front panel flush with the front of the rack. See Figure 44 as an example.

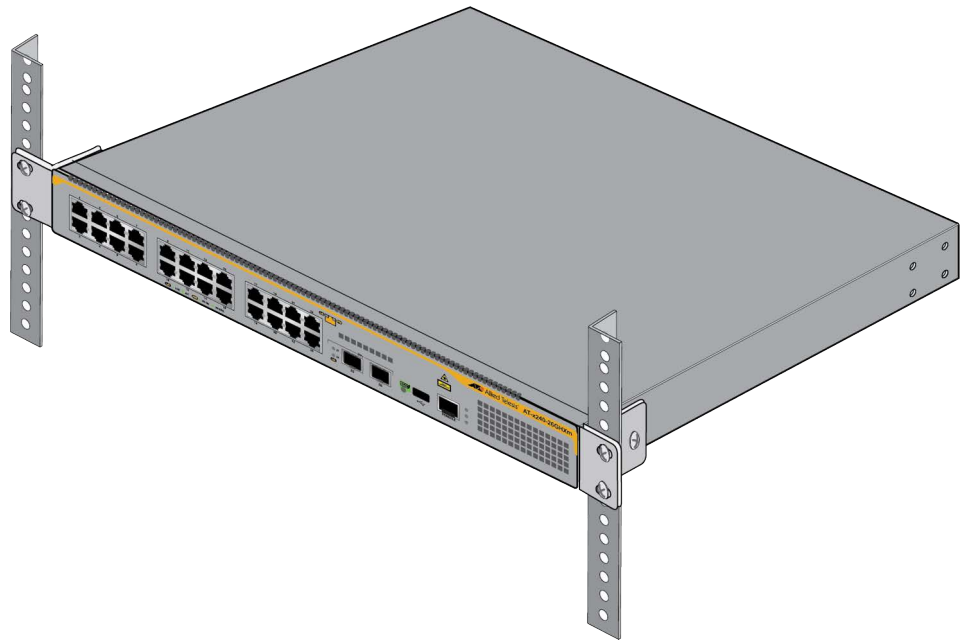

Figure 44. x240-26GHXm Switch in an Equipment Rack

Installing the Switch

To install the switch in a 19-inch equipment rack, perform the following procedure:



Caution

The chassis can be heavy and awkward to lift. Allied Telesis recommends that you get assistance when mounting the chassis in an equipment rack. E28

1. Review the installation guidelines in “Choosing a Site for the Switch” on page 46.
2. Place the switch on a level, secure surface.
3. Attach the two brackets to the sides of the switch, using the six M4x8mm screws supplied with the unit. See Figure 45 as an example.

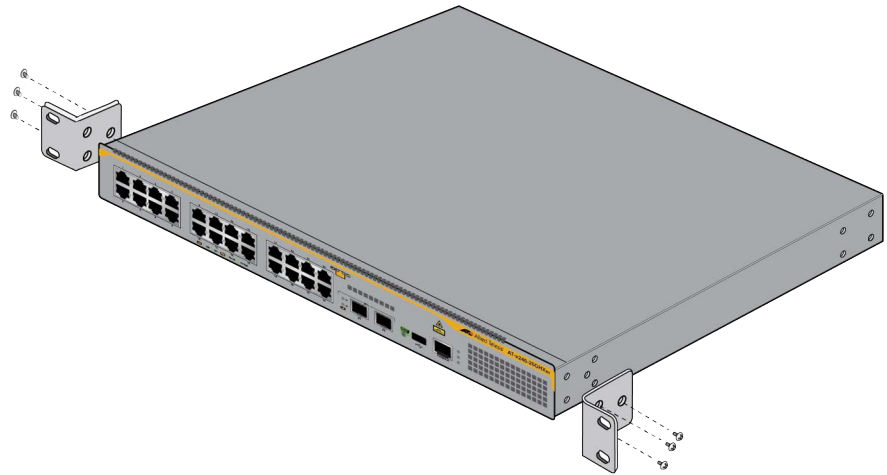

Figure 45. Attaching the Equipment Rack Brackets to the x240-26GHXm Switch

4. Have another person hold the switch at the desired location in the equipment rack while you secure it using four standard equipment rack screws (not provided). See Figure 46 as an example.

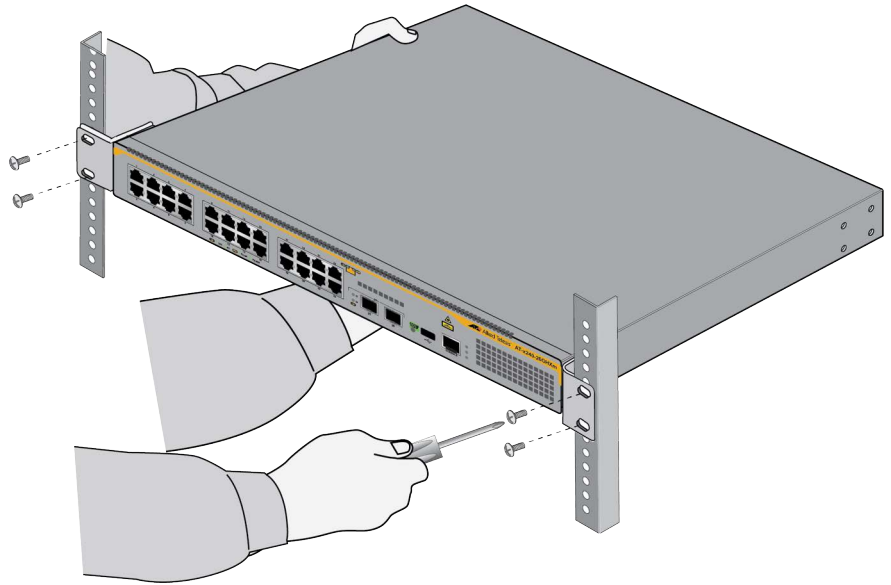

Figure 46. Installing the x240-26GHXm Switch in an Equipment Rack

5. Go to Chapter 6, “Cabling the Networking Ports” on page 85.

Chapter 5

Installing the Switch on a Wall Using the BRKT-J24 Wall Mount Kit

The procedures in this chapter are listed here:

- “Switch Orientations on a Wall” on page 76
- “Installation Guidelines” on page 77
- “Installing the Switch on a Wall Using the BRKT-J24 Brackets” on page 78

Switch Orientations on a Wall

You can install the x240 series switches on a wall with the front panel facing the left or right as shown in Figure 47. Do not install it with the front panel on the top or bottom.

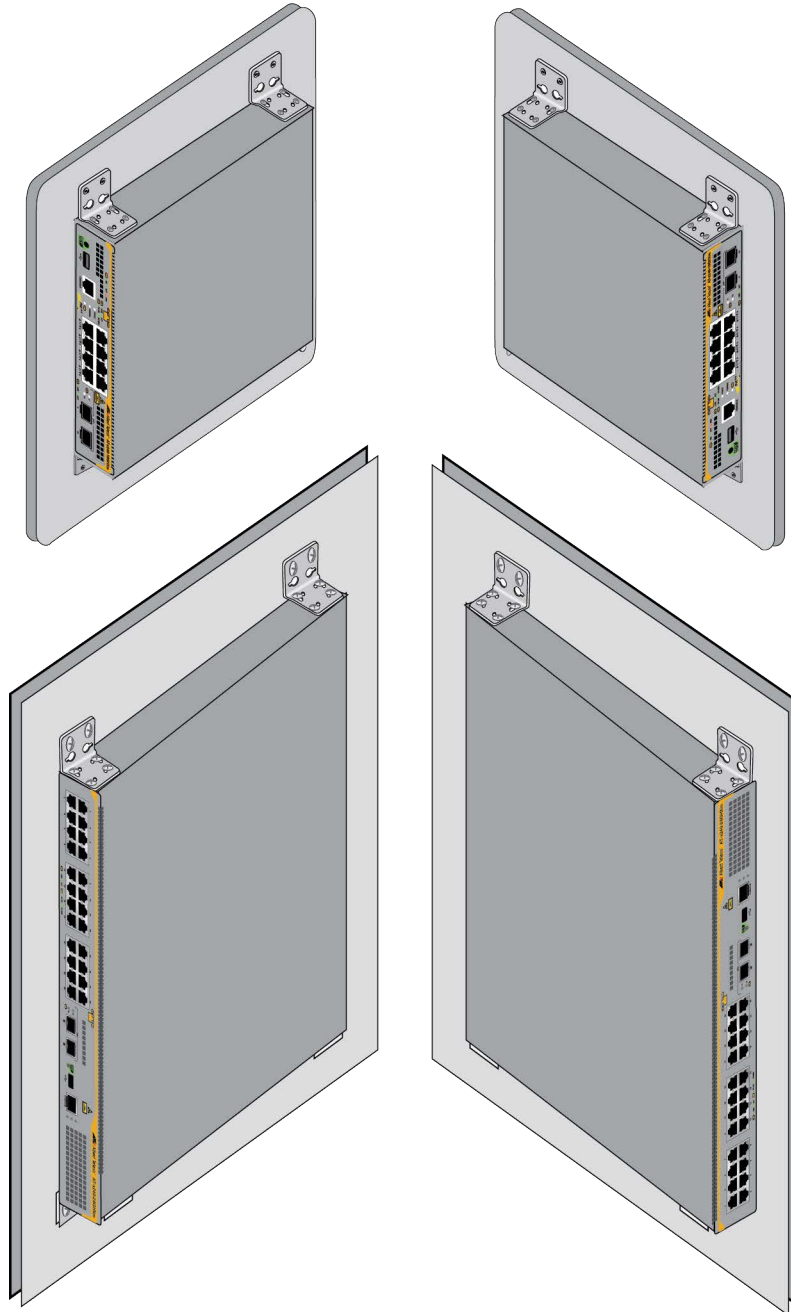

Figure 47. Positioning the x240 Series Switches on the Wall

Installation Guidelines

Here are the guidelines to installing the switch on a wall:

- ❑ Wall installation requires the optional BRKT-J24 brackets kit (BRKT-J24 kit sold separately).
- ❑ The wall can be sheetrock, wood, or concrete.
- ❑ The selected wall location should provide sufficient space from other devices and walls so you can easily access the front and back panels, and for adequate airflow for ventilation.
- ❑ If bumper feet are attached, remove the. Refer to Figure 39 on page 67.
- ❑ Review the safety precautions in this guide “Reviewing Safety Precautions” on page 42.



Warning

The device should be installed on a wall by a qualified building contractor. Serious injury to yourself or others or damage to the equipment may result if it is not properly fastened to the wall. *⚡*
E105

Tools and Material

Here are the required tools and material for installing the switch on a wall:

- ❑ Four BRKT-J24 wall brackets and sixteen M4x6mm screws (BRKT-J24 kit sold separately).
- ❑ Eight wall anchors and eight 4x32mm screws for attaching the brackets to the wall (not provided).
- ❑ Cross-head screwdriver (not provided).
- ❑ Pencil (not provided).
- ❑ For a concrete wall, drill and 1/4” carbide drill bit (not provided).
- ❑ For a sheetrock or wooden wall, a stud-finder capable of identifying the middle of studs and hot electrical wires (not provided).

Installing the Switch on a Wall Using the BRKT-J24 Brackets

This section contains the instructions for installing the device on a wall. Please review the information in the following sections before performing the procedure:

- “Switch Orientations on a Wall” on page 76
- “Installation Guidelines” on page 77



Warning

The device should be installed on the wall by a qualified building contractor. Serious injury to yourself or others or damage to the equipment may result if it is not properly fastened to the wall. *EW*
E105

To install the device on a wall, perform the following procedure:

1. Place the switch on a table.
2. Install the four BRKT-J24 wall brackets, two on each side of the of the unit, with the 16 M4x6mm screws included in the bracket kit. Refer to Figure 48 on page 79.

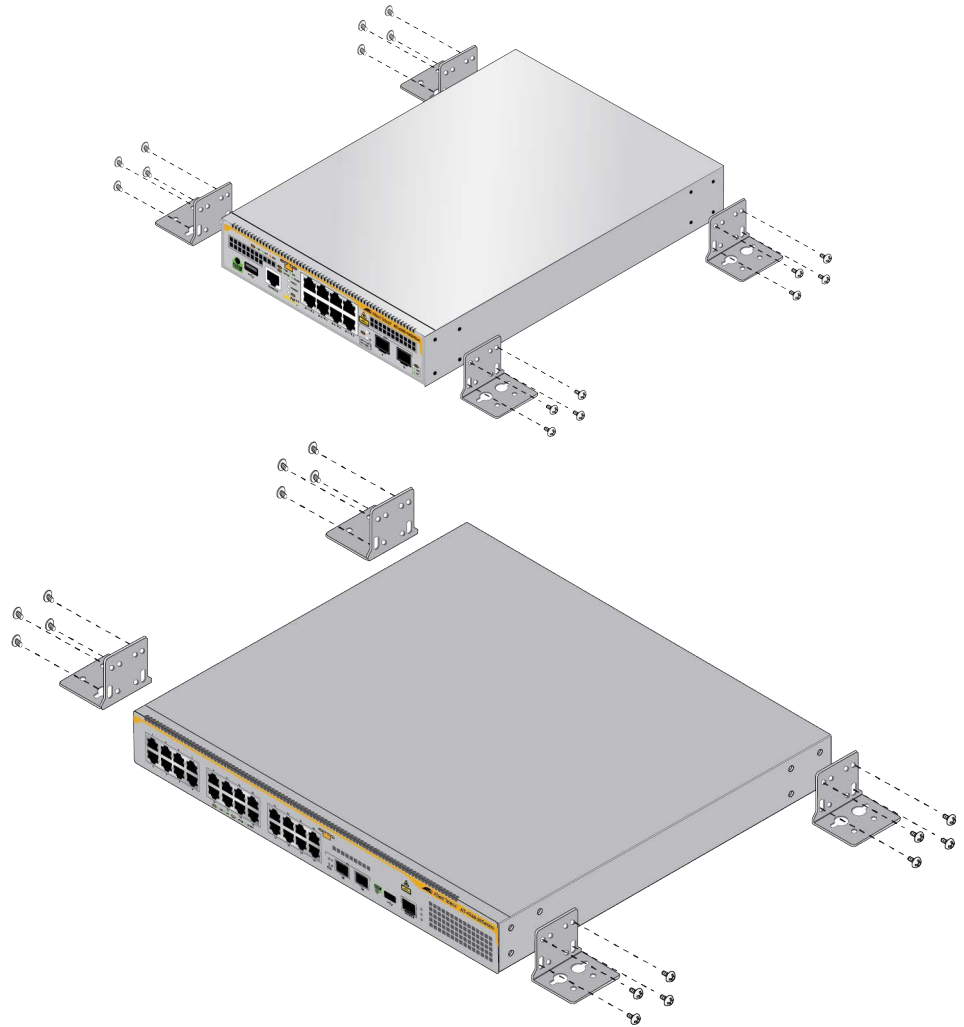

Figure 48. Attaching the Wall Brackets to the Switch

3. Have another person hold the switch at the selected wall location while you mark the wall using the same keyhole of each bracket with a pencil. Refer to Figure 49 on page 80.

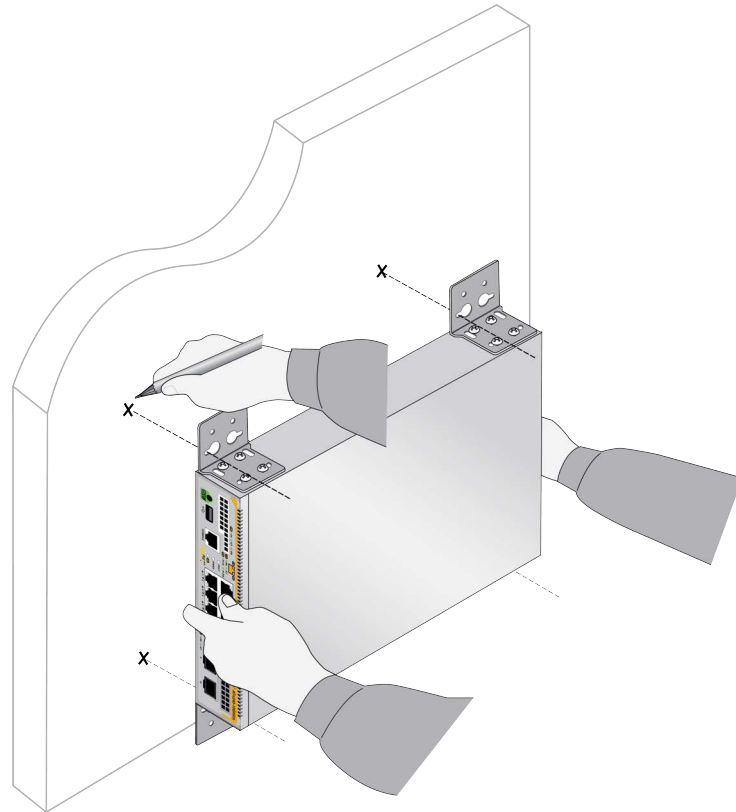

Figure 49. Marking the Locations of the Bracket Keyholes on a Wall

4. Place the switch on a table.
5. For a sheetrock or wooden wall, use a stud-finder to check for live electrical wires at the locations of the screw holes.
6. If required, pre-drill the screw holes on the wall. For a concrete wall, use a drill and a 1/4-inch carbide drill bit to pre-drill the holes you marked in step 3. Please review the following guidelines:
 - Prior to drilling, set the drill to hammer and rotation mode. The modes break up the concrete and clean out the hole.
 - Clean out the holes with a brush or compressed air.
7. If anchors are required, insert them into the holes.
8. Have another person hold the switch at the selected wall location while you secure it to the wall using the appropriate screws into the same keyhole of each bracket. Refer to Figure 53 on page 83.

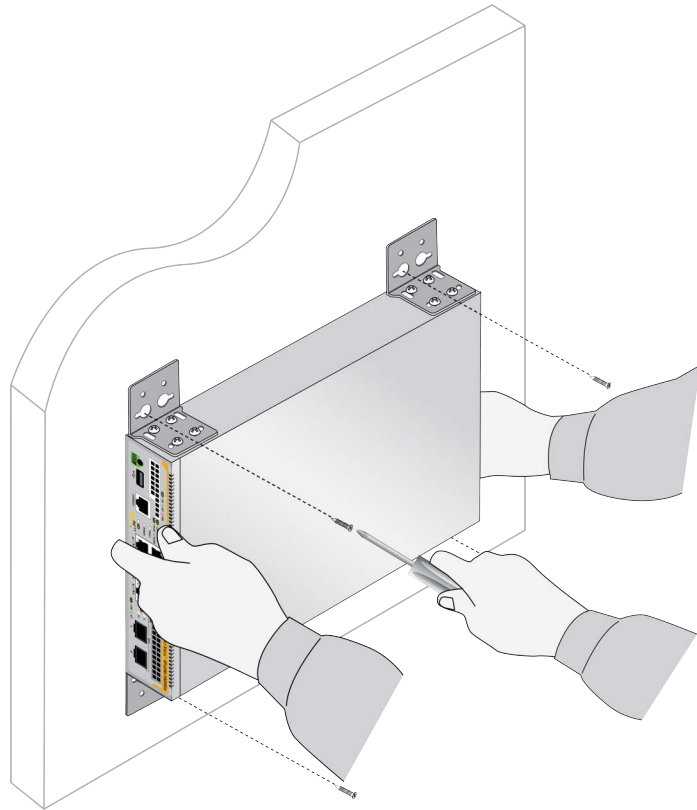

Figure 50. Securing the Switch to the Wall Using the Keyhole

10. After four brackets have been screwed into the wall using the keyhole, move the switch (left or right as appropriate) so that the screws are in the narrow part of the keyhole. Refer to Figure 51 on page 82.

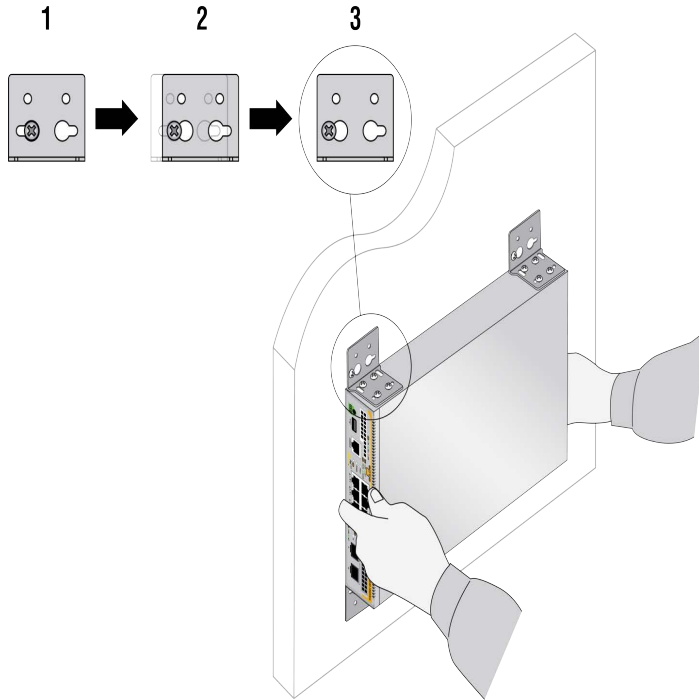

Figure 51. Securing the Chassis Using the Keyhole

11. Continue to secure the switch with screws in the screw holes that are diagonally across from the keyhole in the bracket. Refer to Figure 52.

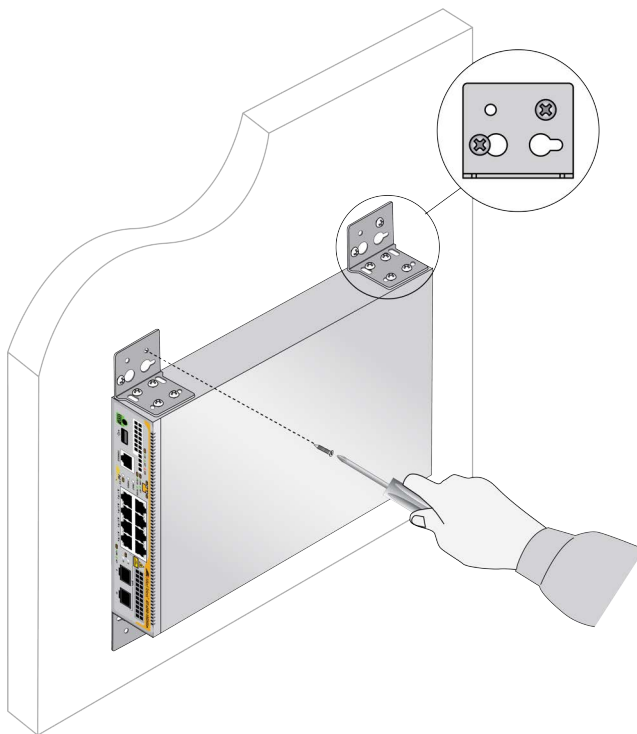

Figure 52. Securing the Switch Using the Screw Holes

12. When the steps are completed. The wall mounting should look as shown in Figure 53.

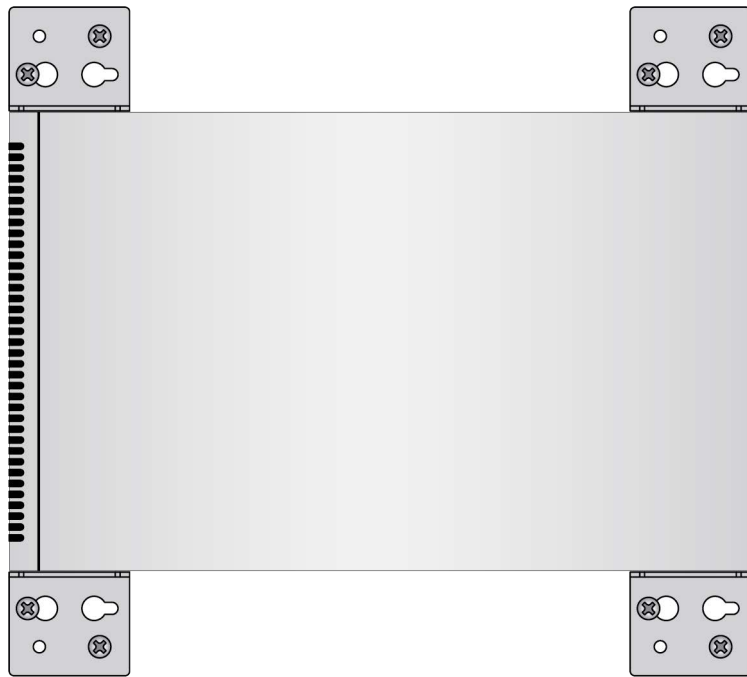

Figure 53. Wall Mounting of Switch, Brackets, and Screws (Top View)

Go to Chapter 6, “Cabling the Networking Ports” on page 85

Chapter 6

Cabling the Networking Ports

This chapter contains the following procedures:

- “Cabling Copper Ports” on page 86
- “Installing SFP and SFP+ Transceivers” on page 88
- “Installing SP10TW Direct Connect Cables” on page 92

Cabling Copper Ports

Here are the guidelines to cabling the copper ports:

- ❑ The minimum cable requirements are as follows:
 - 10M: Standard TIA/EIA 568-compliant Category 3, 100 ohm unshielded cabling, complying with IEEE 802.3i 10Base-T specifications.
 - 100M: Standard TIA/EIA 568-compliant Category 5, 100 ohm unshielded cabling, complying with IEEE 802.3u 100Base-TX specifications.
 - 1/2.5/5G: Standard TIA/EIA 568-A-compliant Category 5 or TIA/EIA 568-B-compliant Enhanced Category 5 (Cat 5e) unshielded cabling.
- ❑ The connectors on the cables should fit snugly into the ports, and the tabs should lock the connectors into place.
- ❑ The default setting for the wiring configurations of the ports is auto-MDI/MDI-X. The default setting is appropriate for switch ports that are connected to 10/100Base-TX network devices that also support auto-MDI/MDI-X.
- ❑ The default auto-MDI/MDI-X setting is not appropriate for switch ports that are connected to 10/100Base-TX network devices that do not support auto-MDI/MDI-X and have a fixed wiring configuration. For switch ports connected to those types of network devices, you should disable auto-MDI/MDI-X and set the wiring configurations manually.
- ❑ The appropriate MDI/MDI-X setting for a switch port connected to a 10/100Base-TX network device with a fixed wiring configuration depends on the setting of the network device and whether the switch and network device are connected with straight-through or crossover cable. If you are using straight-through twisted pair cable, the wiring configurations of a port on the switch and a port on a network device must be opposite each other, such that one port uses MDI and the other MDI-X. For example, if a network device has a fixed wiring configuration of MDI, you must disable auto-MDI/MDI-X on the corresponding switch port and manually set it to MDI-X. If you are using crossover twisted pair cable, the wiring configurations of a port on the switch and a port on a network device must be the same.
- ❑ PoE is enabled by default on the x240-10GHXm and x240-26GHXm Switch ports.

- ❑ The default speed setting for the wiring configurations of the ports is Auto-Negotiation. This setting is appropriate for ports connected to network devices that also support Auto-Negotiation.
- ❑ The ports must be set to the default setting of Auto-Negotiation to operate at 1G and higher speeds.
- ❑ The copper ports operate at full-duplex mode when operating at 10M/100M/1G.
- ❑ Do not attach cables to ports of static or Link Aggregation Control Protocol (LACP) port trunks until after you configure the trunks on the switch. Otherwise, the ports will form network loops that can adversely affect network performance.

**Caution**

Disable PoE on ports before connecting or disconnecting copper cables to prevent damaging the switch. Disconnecting Ethernet copper network cables while the switch is providing power to powered devices (PDs) can damage the switch. *⚡* **E131**

Installing SFP and SFP+ Transceivers

This section contains instructions for installing SFP and SFP+ transceivers in the ports on the switch.

Review this information before installing transceivers:

- ❑ Ports 9 and 10 on the x240-10GHXm and x240-10GTXm switches support 1G SFP and 10G SFP+ transceivers. They do not support 100M SFP transceivers.
- ❑ Ports 25 and 26 on the x240-26GHXm and x240-26GTXm switches support 1G SFP and 10G SFP+ transceivers. They do not support 100M SFP transceivers.

Review the following guidelines before installing SFP or SFP+ transceivers:

- ❑ SFP and SFP+ transceivers are hot-swappable. You can install them while the switch is powered on.

Note

For a list of supported transceivers, refer to the product data sheet on the Allied Telesis web site.

- ❑ The operational specifications and fiber optic cable requirements of the transceivers are provided in the documents included with the devices.
- ❑ Install a transceiver before connecting the fiber optic cable.
- ❑ Fiber optic transceivers are dust sensitive. Always keep the plug in the optical bores when a fiber optic cable is not installed, or when you store the transceiver. When you do remove the plug, keep it for future use.
- ❑ Unnecessary removal and insertion of a transceiver can lead to premature failure.



Caution

Transceivers can be damaged by static electricity. Be sure to observe all standard electrostatic discharge (ESD) precautions, such as wearing an antistatic wrist strap, to avoid damaging the devices.  E92

Installing SFP and SFP+ Transceiver

The illustrations in the procedure show a transceiver being installed in port 9 of a 10-port switch. The procedure is the same for all SFP and SFP+ ports. The transceiver in the illustrations has a duplex LC connector. The connector on your transceivers may be different.

To install transceivers, perform the following procedure:

1. If the transceiver port has a dust plug, remove it as shown in Figure 54.

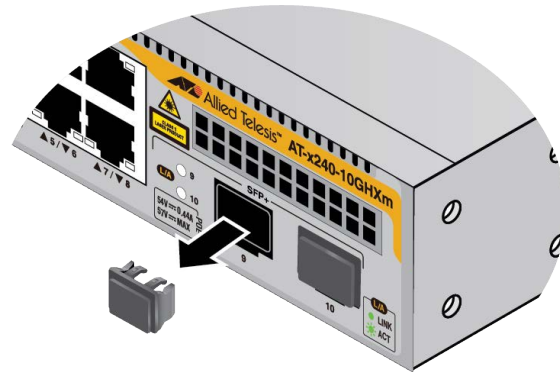

Figure 54. Removing the Dust Plug from an SFP+ Port

2. Remove the transceiver from its shipping container and store the packaging material in a safe location.
3. Position the transceiver with the Allied Telesis label facing up.
4. Slide the transceiver into the port until it clicks into place, as shown in Figure 55.

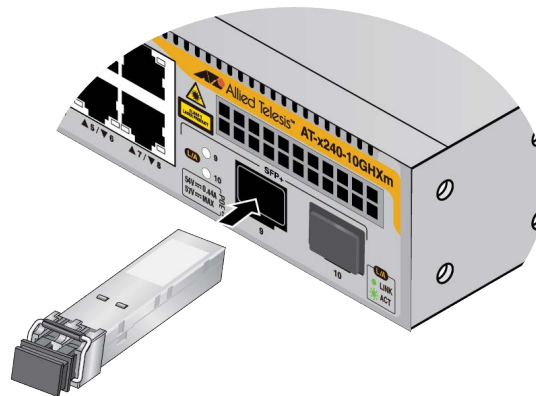

Figure 55. Installing SFP+ Transceivers

Note

If you are ready to attach the fiber optic cable to the transceiver, continue with the next step. Otherwise, repeat steps 1 to 4 to install the remaining transceivers in the switch.

5. Remove the dust cover from the transceiver. See Figure 56.

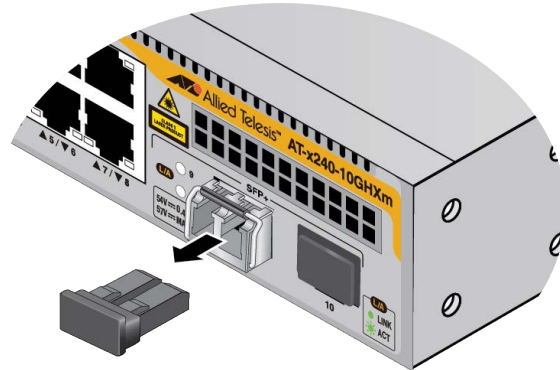

Figure 56. Removing the Dust Cover from an SFP or SFP+ Transceiver

6. Verify the position of the handle on the transceiver.

The transceiver handle should be in the upright position, as shown in Figure 57.

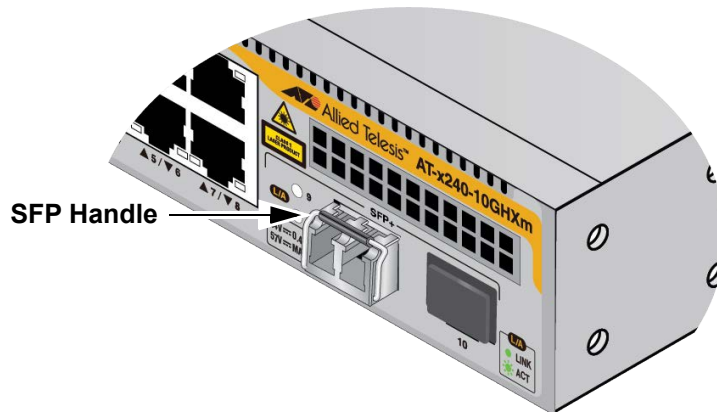

Figure 57. Positioning the SFP or SFP+ Handle in the Upright Position

7. Connect the fiber optic cable to the transceiver, as shown in Figure 58 on page 91.

The connector on the cable should fit snugly into the port, and the tab should lock the connector into place.

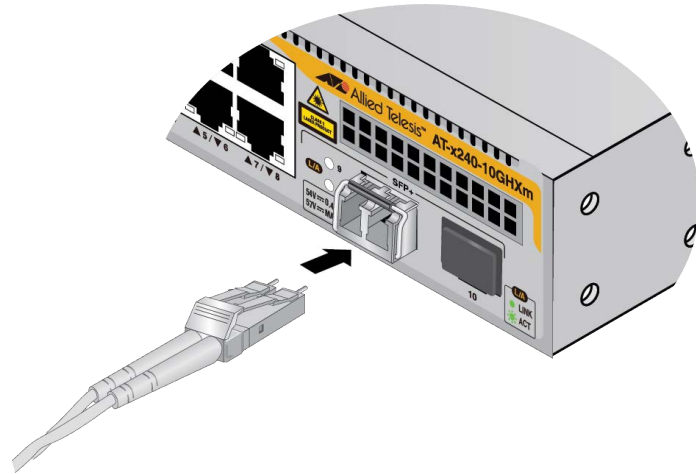

Figure 58. Connecting a Fiber Optic Cable to an SFP or SFP+ Transceiver

8. Repeat this procedure to install and cable additional transceivers.

Installing SP10TW Direct Connect Cables

The following SFP+ transceiver ports of the switches support SP10TW direct connect twinax cables:

- ❑ x240-10GHXm and x240-10GTXm: ports 9 and 10
- ❑ x240-26GHXm and x240-26GTXm: ports 25 and 26

The cables are an economical way to add 10G connections over short distances. They have SFP+ transceivers on both ends and come in lengths of 1 and 3 meters.

Note

The switches do not support the 7-meter SP10TW7 cable.

Installing SP10TW Direct Connect Cable

To install SP10TW direct connect cables, perform the following procedure:

1. If the SFP+ port has a dust cover, remove it. See Figure 56 on page 90.
2. Remove the SP10TW direct connect cable from its shipping container and store the packaging material in a safe location.
3. If there is a dust cap, remove the dust cap from a connector on the cable.
4. Slide the connector into the slot. The release tab on the connector must be on the top. See Figure 59.

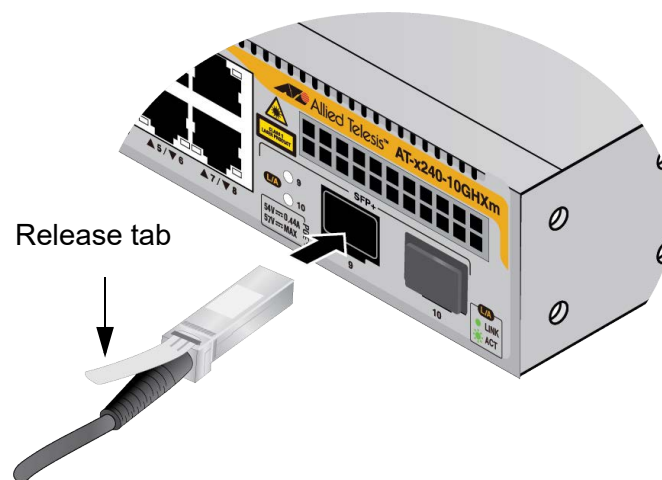

Figure 59. Installing SP10TW Cables

5. Repeat this procedure to install the other end of the cable into a port on another network device.

Note

To remove the connector and cable from the port, gently push on the connector, pull on the release tab, and slide the connector from the port.

6. Go to Chapter 7, “Powering On the Switch” on page 95.

Chapter 7

Powering On the Switch

This chapter contains the following procedure:

- “Powering On the Switch” on page 96

Powering On the Switch

Before powering on the switch, review the information in “Power Specifications” on page 124 for the power specifications.



Warning

Power cord is used as a disconnection device. To de-energize equipment, disconnect the power cord. ⚡ E3

Note

Pluggable Equipment. The socket outlet shall be installed near the equipment and shall be easily accessible. ⚡ E5

To power on the switch, perform the following procedure:

1. Install the power cord retaining clip on the AC power connector on the rear panel of the switch, as shown in Figure 60.

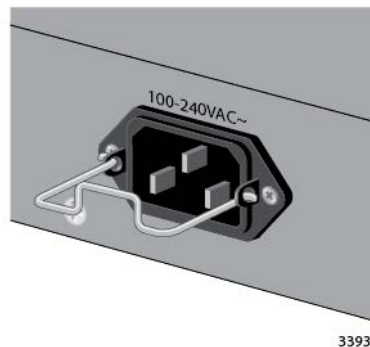
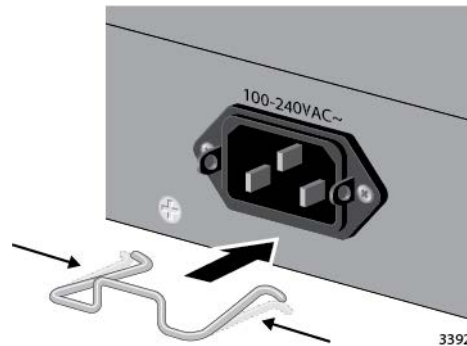

Figure 60. Installing the Power Cord Retaining Clip

2. Connect the AC power cord to the AC power connector on the rear panel. Refer to Figure 61.

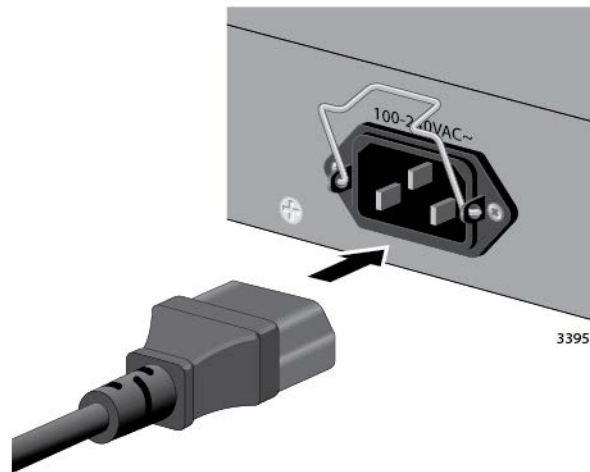
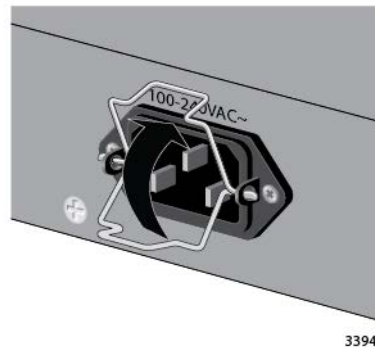

Figure 61. Connecting the AC Power Cord

3. Lower the power cord retaining clip to secure the cord to the switch. Refer to Figure 62.

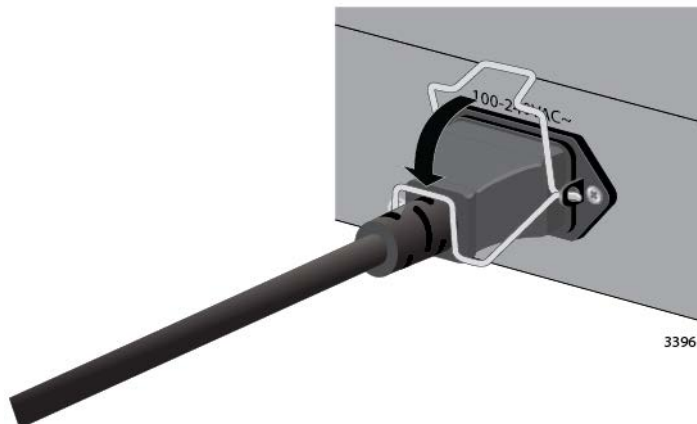

Figure 62. Lowering the Power Cord Retaining Clip

4. Connect the power cord to an appropriate AC power source. Refer to Figure 63.

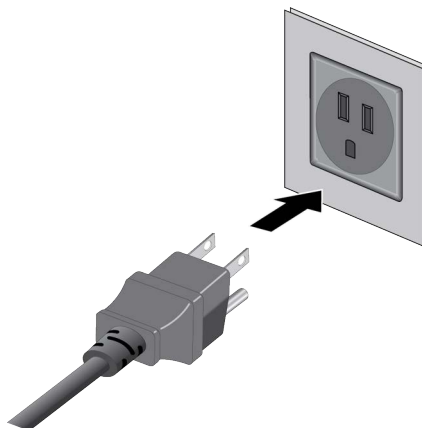

Figure 63. Connecting the Power Cord to an AC Power Source

Note

The illustration shows a North American power cord. Your power cord may be different.

5. Wait two minutes for the switch to initialize the management software.

The installation is complete. The switch is now ready for network operations. To start managing the switch, refer to Chapter 8, “Managing the Switch” on page 99.

Chapter 8

Managing the Switch

This chapter contains the following procedures:

- ❑ “Starting a Management Session” on page 100
- ❑ “Verifying the Switch” on page 105
- ❑ “Specifying Ports in the Command Line Interface” on page 106

Starting a Management Session

The following procedures explain the different methods for starting a management session on the switch:

- ❑ “Through the Console Port,” next
- ❑ “With a DHCP Server” on page 102
- ❑ “With the Default IPv4 Address” on page 103

After starting your initial management session, go to “Verifying the Switch” on page 105.

The switch has two build-in management interfaces:

- ❑ The command line interface is access through the Console port on the switch and over your network with a Telnet or Secure Shell (SSH) application.
- ❑ The web browser interface is accessed over your network.

Here are the procedures for starting the first management session on the switch.

Through the Console Port

This section explains how to start a local management session with the command line interface through the Console port. Here are the guidelines:

- ❑ Local management sessions require a terminal, computer, or laptop with an RS-232 serial port or USB port, and a terminal emulator, such as PuTTY.
- ❑ Local management sessions also require a management cable. If your computer has an RS-232 port, refer to “RJ-45 Style Serial Console Port Pinouts” on page 127 for the cable wiring specifications.
- ❑ If your computer has a USB port, you will need a USB-to-Serial converter that is compatible with its operating system. An example is the VT-Kit3 converter from Allied Telesis. Refer to Figure 8 on page 19.
- ❑ Local management sessions do not interfere with the network operations of the switch.
- ❑ The switch does not need an IP address for local management sessions.
- ❑ The switch comes from the factory without a configuration file for storing its parameter settings. It automatically creates a file the first time you save the parameter settings.

To start a local management session, perform the following procedure:

1. Connect your terminal, computer, or laptop to the Console port on the switch.
 - If your workstation has a DB-9 female connector, refer to “Console Management Cable with DB-9 Female and RJ-45 Connectors” on page 128 for the cable specifications.
 - If it has a USB port, you may need to purchase a USB-to-Serial converter that is compatible with its operating system. An example is the VT-Kit3 converter from Allied Telesis shown in Figure 64.

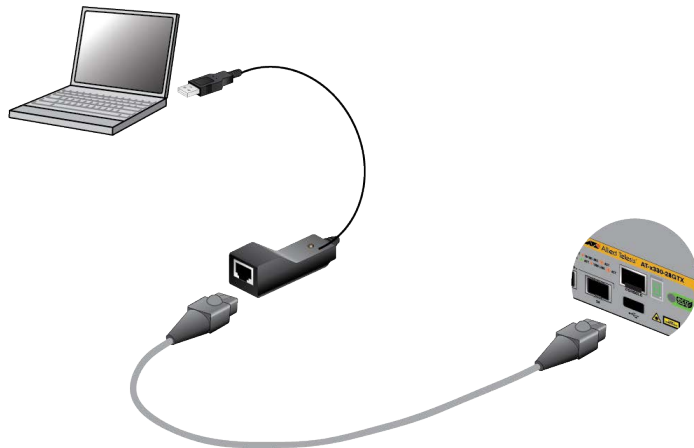

Figure 64. VT-Kit3 Management Cable with Workstation and Switch

2. Configure your terminal or emulation as:
 - Baud rate: 9600 bps (The baud rate of the Console port is adjustable from 1200 to 115200 bps. The default is 9600 bps.)
 - Data bits: 8
 - Parity: None
 - Stop bits: 1
 - Flow controller: None

Note

The port settings are for a DEC VT100 or ANSI terminal, or an equivalent terminal emulator program.

Note

The baud rate must be set to the default 9600 bps to configure the boot loader.

3. Power on the switch and wait several minutes for it to initialize the AlliedWare Plus™ software. Its test and initialization message are displayed on your screen. Wait for the login prompt.
4. Press Enter. You are prompted for the name and password of the manager account.
5. Enter the user name and password. The default values are “manager” and “friend” (without the quotes), respectively.

Note

User names and passwords are case sensitive.

The switch starts the local management session and displays the following prompt:

```
awp1us>
```

The prompt identifies the User Exec mode of the command line interface.

6. Go to “Verifying the Switch” on page 105.

With a DHCP Server

This section contains the procedure for starting the first management session with the switch on a network that has a DHCP or DHCPv6 server. Review the following factory default settings for the switch when powered on for the first time:

- DHCP and DHCPv6 clients: enabled
- SSH server: enabled
- Telnet server: disabled
- Switch ports: enabled
- VLAN membership: port-based VLAN1
- Configuration file: none (The switch automatically creates a configuration file the first time you save its parameter settings.)

Note

As listed above, the default settings for the SSH and Telnet clients when the switch is powered on for the first time are enabled and disabled, respectively. However, their settings in the initial configuration file are reversed, with SSH disabled and Telnet enabled. Unless you change their settings manually, that will be their settings if you reboot the switch after it saves its first configuration file.

To start a management session on the switch over a network that has a DHCP server, perform the following procedure:

1. Add the new switch to the DHCP server so that the server assigns it an IP address. The MAC address of the switch can be found on a label on the bottom or rear panel.
2. Connect a single Ethernet port on the switch to your existing network.
3. Power on the switch. Wait several minutes for it to finish initializing the AlliedWare Plus software and obtain its assigned IPv4 or IPv6 address from the DHCP server.
4. On your management workstation, enter the switch's assigned IP address into a Secure Shell (SSH) application or the URL field of your web browser on your workstation.
5. Press Enter. You are prompted for the name and password of the manager account.
6. Enter the user name and password. The default values are "manager" and "friend" (without the quotes), respectively.

Note

User names and passwords are case sensitive.

The switch starts the local management session and displays the following prompt:

```
awp1us>
```

The prompt identifies the User Exec mode of the command line interface.

7. Go to "Verifying the Switch" on page 105.

With the Default IPv4 Address

This section contains the procedure for starting the first management session with the switch using its default IPv4 address. Review the following factory default settings for the switch when powered on for the first time:

- Default IP address without DHCP server: 169.254.42.42 (255.255.0.0)
- SSH server: enabled
- Telnet server: disabled
- Switch ports: enabled

- ❑ VLAN membership: port-based VLAN1
- ❑ Configuration file: none (The switch automatically creates a configuration file the first time you save its parameter settings.)

Note

As listed above, the default settings for the SSH and Telnet clients when the switch is powered on for the first time are enabled and disabled, respectively. However, their settings in the initial configuration file are reversed, with SSH disabled and Telnet enabled. Unless you change their settings manually, that will be their settings if you reboot the switch after it saves its first configuration file.

On networks without a DHCP server, you can use the switch's default IPv4 address to start a remote management session, as explained in the following procedure:

1. Change the IP address of your workstation to 169.254.42.*n*/16 (255.255.0.0), where *n* is any number from 1 to 254, but not 42.
2. Connect the Ethernet port on your workstation to an Ethernet port on the switch.
3. Power on the switch. Wait several minutes for it to finish loading the AlliedWare Plus software.
4. Enter the IP address 169.254.42.42, the switch's default IP address, in an SSH application or the URL field of the web browser on your workstation.
5. Press Enter. You are prompted for the name and password of the manager account.
6. Enter the user name and password. The default values are "manager" and "friend" (without the quotes), respectively.

Note

User names and passwords are case sensitive.

The switch starts the local management session and displays the following prompt:

```
awp1us>
```

The prompt identifies the User Exec mode of the command line interface.

7. Go to "Verifying the Switch" on page 105.

Verifying the Switch

To verify the basic hardware operations of the switch, perform the following procedure:

1. Start a local or remote management session.

Note

Steps 2 and 3 display the status of the hardware components and the switches.

2. Enter the `SHOW SYSTEM ENVIRONMENT` command in the User Exec or Privileged Exec mode.
3. Check the Status column. All components should have the status "OK".

Note

Steps 4 and 5 confirm the PoE status on the x240-10GHXm and x240-26GHXm Switches.

4. If you connected PoE devices to the switch, examine the devices to confirm that they are receiving power and operating normally.
5. Enter the `SHOW POWER-INLINE` command in the User Exec or Privileged Exec mode and check the command output for the following:
 - Nominal Power for the x240-10GHXm Switch is 240W. Nominal Power for the x240-26GHXm Switch is 370W
 - All ports should have the Admin status of Enabled.
 - Ports connected to powered devices should have the Operational (Oper) status of Powered.

Specifying Ports in the Command Line Interface

The individual ports on the switches are specified in the command line interface with the PORT parameter. The format of the parameter is shown in Figure 65.

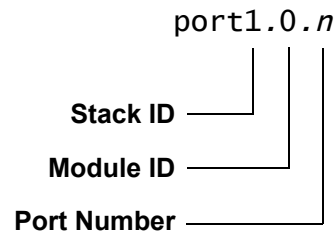

Figure 65. PORT Parameter in the Command Line Interface

The three parts of the PORT parameter are described in Table 11.

Table 11. PORT Parameter Format

Number	Description
Stack ID	Designates the switch's ID number. The correct value is "1" for the x240 Switch.
Module ID	Designates the module number of a port. The x240 Series switches do not have modules, consequently, this value is always 0 (zero).
Port Number	Designates a port number.

The following is an example of the PORT parameter. It uses the `INTERFACE` command to enter the Port Interface mode for ports 1 and 3:

```
awplus> enable
awplus# configure terminal
awplus(config)# interface port1.0.1,port1.0.3
```

For instructions on the command line interface and the PORT parameter, refer to the *Command Reference: x240 Series Switches Running AlliedWare Plus* at www.alliedtelesis.com/library.

Chapter 9

Management Stacking

This chapter describes how to create and use a management stack.

- ❑ “Overview” on page 108
- ❑ “Setting Up a Management Stack” on page 109
- ❑ “Checking the Status of the Stack” on page 112
- ❑ “Running Commands on Devices in the Management Stack” on page 113
- ❑ “Copying Files Between Management Stack Members” on page 114

Overview

Management Stacking enables multiple network devices to be managed from a single console, using CLI commands issued from a single command switch to another switch in the stack. You can use the command node's IP address to reach any device in the stack. This feature reduces the burden of managing many individual devices.

Management stacking supports up to 32 devices in the stack. Only one device can be controlled at a time via the command node.

Command Node The command node is the parent device in the management stack. You can control other nodes in the management stack from the command node.

Node A management stacking node is a network device that is attached to a network, and is capable of sending, receiving, or forwarding information over a communications channel.

Management Stack A management stack is a group of switches across a network, where one switch is used as a command node. The other switches in the stack can be managed from the command node. Refer to "Setting Up a Management Stack" on page 109.

Setting Up a Management Stack

This example illustrates configuring three switches in a management stack. Each management stacking member will need to be given a unique host name. In this example, the first unit in the management stack is the command node, the second is referred to as node-01, and the third as node-02. Refer to Figure 66.



Figure 66. Management Stack of Nodes

You cannot give different members the same hostname with different capitalization. For example, you cannot call one member “node-a”, and another member “node-A”.

Note

In order to configure and use management stacking, AMF must first be disabled on each device in the stack, including the command node.

Step 1: Configuring the Command Node

This step configures the device as a management stacking command node. A management stacking command node must be present for a management stack to form. Only one device in the management stack can be the command node.

1. Name the device by giving it a host-name.

```
awplus(config)#hostname command-node
```

2. Disable AMF and enable management stacking. AMF and management stacking cannot be used at the same time.

```
command-node(config)#no atmf enable
```

```
% Warning: After disabling ATMF a config save  
and system restart is recommended.
```

```
command-node(config)#mstack enable
```

3. Assign the device to be the command node.

```
command-node(config)#mstack command-node
```

4. Enter the interface mode for the port, or ports, that will link the command node to other members in the stack. Specify that the port is part of the management stacking link.

```
command-node(config)#int port1.0.1
```

```
command-node(config-if)#switchport mstack-link
```

5. After configuring the command-node, log out and log in again.

Step 2: Configuring Node-01

This step sets the hostname on the second unit to 'node-01', and adds it to the stack.

1. Name the device by giving it a hostname.

```
awplus(config)#hostname node-01
```

2. Disable AMF and enable management stacking. AMF and management stacking cannot be used at the same time.

```
node-01(config)#no atmf enable
```

Warning: After disabling ATMF a config save and system restart is recommended.

```
node-01(config)#mstack enable
```

3. Enter interface mode for the ports that will link this node to other members in the stack. Specify that the ports are part of the management stacking link.

```
node-01(config)#int port1.0.1-1.0.2
```

```
node-01(config-if)#switchport mstack-link
```

When port1.0.1 of node-01 is connected to port1.0.1 of the command node, then node-01 will join the management stack and the following information will be displayed:

```
node-01(config-if)#01:11:15 node-01
```

```
MSTACK[910]: command-node has joined. 2 members  
in total.
```

Step 3: Configuring Node-02

This step sets the hostname on the second unit to 'node-02', and adds it to the stack.

1. Name the device by giving it a hostname.

```
awplus (config) #hostname node-02
```

2. Disable AMF and enable management stacking. AMF and management stacking cannot be used at the same time.

```
node-02 (config) #no atmf enable
```

```
% Warning: After disabling ATMF a config save
and system restart is recommended.
```

```
node-02 (config) #mstack enable
```

3. Enter interface mode for the port or ports that will link this node to other members in the stack. Specify that the port is part of the management stacking link.

```
node-02 (config) #int port1.0.2
```

```
node-02 (config-if) #switchport mstack-link
```

When port1.0.2 of node-02 is connected to port1.0.2 of node-01, then node-02 will join the management stack and the following information will be displayed:

```
node-02 (config-if) #01:32:52 node-02
```

```
MSTACK[899]: node-01 has joined. 2 members in
total.
```

```
01:32:52 node-02 MSTACK[899]: command-node has
joined. 3 members in total.
```

Checking the Status of the Stack

You can check the configuration by using the following command:

```
node-02#sh mstack node
```

```
Node Information:

* = Local device

SC = Switch Configuration:
C = Chassis      S = Stackable      N = Standalone

Node          Device          MSTACK
Name          Type            C-Node   SC   Parent          Node
-----
command-node  x240-10GHXm    Y        N   none            0
node-01       x240-10GHXm    N        N   command-node    1
* node-02     x240-10GHXm    N        N   node-01         2

Current MSTACK node count 3
```

The following table explains the meaning of fields in this output.

Table 12. Fields in the Output of the `'show mstack node'` Command

Field	Definition
C-Node	This indicates whether that node is the command node (Y) or not (N).
SC	In a management stack this is 'N' and indicates that the switch is a standalone switch.
Parent	This indicates the switch that is a level above the current node in the management stack hierarchy. This has no effect on the operation of the management stack.
Node Depth	This indicates the distance for the command node. This has no effect on the operation of the management stack.

Running Commands on Devices in the Management Stack

From the command node, you can login to other management stacking nodes in order to run commands as if you were a local user of that node.

1. To remotely login from command-node to node-02, use the following command:

```
command-node#mstack remote-login node-02
```

The following information is displayed:

```
Type 'exit' to return to command-node.
```

```
AlliedWare Plus (TM) 0.0.0 01/07/15 20:00:58
```

```
node-02>
```

2. Enter commands on node-02:

```
node-02>enable
```

```
node-02#<other-commands>
```

3. To return to command-node, use the following command:

```
node-02#exit
```

Note

If the remote login session exits for any reason (i.e., device reboot) the user will be returned to the originating node. Users are prevented from multiple remote login sessions. You must exit the existing session, before starting a new session.

Copying Files Between Management Stack Members

To copy files between members in the management stack, you need to be logged into either the source or destination switch.

Using Remote Login to Copy Files Between Other Units in the Management Stack

This example shows how to copy files between a second and third x240 unit remotely from the command node. In this example, the second and third x240 unit in the management stack are called node-01 and node-02 respectively.

1. Log into node-01 remotely from the command node, and change the mode.

```
command-node#mstack remote-login node-01
```

```
Type 'exit' to return to command-node.
```

```
AlliedWare Plus (TM) 0.0.0 01/07/15 20:00:58
```

```
node-01>enable
```

2. Use the copy command to copy files from node-01 to node-02. Note that the path to the node's flash memory is of the form <node-hostname>.mstk/<filesystem>.

```
node-01#copy test.txt node-02.mstk/flash
```

```
Enter destination file name[test.txt]:
```

```
Copying...
```

```
Successful operation
```

3. To return to the command node, use the exit command.

```
node-01#exit
```

```
command-node#
```

Chapter 10

Troubleshooting

This chapter contains suggestions on how to troubleshoot problems with the switch.

Note

For further assistance, please contact Allied Telesis Technical Support at www.alliedtelesis.com/support.

Problem 1: All the port and system LEDs are off, and the fan is not operating.

Solutions: The unit is not receiving power. Try the following:

- Verify that the power cord is securely connected to the power source and the AC connector on the back panel of the switch.
- Verify that the power outlet has power by connecting another device to it.
- Try connecting the unit to another power source.
- Try a different power cord.
- Verify that the voltage from the power source is within the required levels for your region. The power requirements for the switch are listed in “Power Specifications” on page 124.

Problem 2: All of the port LEDs are off even though the ports are connected to active network devices.

Solution: The switch might be operating in the low power mode. To toggle on the LEDs, press the eco-friendly button on the front panel of the switch. You can also toggle the LEDs off and on with the `ECOFRIENDLY LED` and `NO ECOFRIENDLY LED` commands in the command line interface.

Problem 3: A LINK/ACT LED is off for a copper port that is connected to an active network device.

Solutions: The port is unable to establish a link to a network device. Try the following:

- Verify that the network device connected to the copper port is powered on and is operating properly.

- ❑ Verify that the copper cable is securely connected to the ports on the switch and network device.
- ❑ Start a local or remote management session on the switch and enter the `SHOW INTERFACE STATUS` command to verify that the port is enabled. If necessary, enter the Interface Configuration mode for the port and enter the `NO SHUTDOWN` command to enable it.
- ❑ Try connecting another network device to the copper port with a different cable. If the port is able to establish a link, then the problem is with the cable or the other network device.
- ❑ Verify that the copper cable does not exceed 100 meters (328 feet).
- ❑ Verify that you are using the appropriate category of cable. Cable requirements for the copper ports are given in “Cable Requirements” on page 24.
- ❑ Verify that the port is connected to the correct cable.

Note

Copper ports may require five to ten seconds to establish a link.

Problem 4: Network performance between a copper port on the switch and a port on a network device is slow.

Solution: There might be a duplex mode mismatch between the ports. This can occur when a switch port set to Auto-Negotiation is connected to a remote device with a fixed speed of 10Mbps or 100Mbps and a fixed duplex mode of full-duplex. To resolve the problem, adjust the speed and duplex mode settings on the switch port to match the settings of the port on the network device.

Problem 5: The LINK/ACT LED is off for an SFP transceiver that is connected to an active network device.

Solutions: The fiber optic port on the transceiver is unable to establish a link to a network device. Try the following:

- ❑ Verify that the remote network device is operating properly.
- ❑ Verify that the fiber optic cable is securely connected to the port on the transceiver and to the port on the remote network device.
- ❑ Check that the transceiver is fully inserted in the slot.
- ❑ Verify that the operating specifications of the fiber optic ports on the transceiver and remote network device are compatible.
- ❑ Verify that the correct type of fiber optic cabling is being used.
- ❑ Verify that the port is connected to the correct fiber optic cable.

- ❑ Try connecting another network device to the fiber optic port using a different cable. If the port is able to establish a link, then the problem is with the cable or with the other network device.
- ❑ Use the switch's management software to verify that the port is enabled.
- ❑ If the remote network device is a managed device, use its management firmware to determine whether its port is enabled.
- ❑ If two BiDi (bi-directional) transceivers cannot establish a link, refer to their data sheets to verify that their transmission and reception frequencies are opposite to each other. For instance, a BiDi transceiver that transmits and receives at 1310nm and 1550nm, respectively, has to be connected to a transceiver that transmits and receives at 1550nm and 1310nm, respectively. Two BiDi transceivers cannot establish a link if they transmit and receive at the same frequencies.
- ❑ Test the attenuation of both directions on the fiber optic cable with a fiber optic tester to determine whether the optical signal is too weak (sensitivity) or too strong (maximum input power).

Problem 6: The x240-10GHXm or x240-26GHXm Switch is not providing power to any powered devices or to only a few devices whose total power requirements are below the power budget of 240W, or 370W respectively.

Solution: The power supply in the switch may have a problem. Start a management session and enter the `SHOW SYSTEM ENVIRONMENT` command in the User Exec or Privileged Exec mode of management software to determine the status of the power supply.

Problem 7: A port on the x240-10GHXm or x240-26GHXm Switch is not providing power to a powered device.

Solutions: Try the following:

- ❑ Check the port's PoE LED. Refer to Figure 9 on page 25 and Table 2 on page 26. If the LED is flashing green, the switch cannot support additional PoE devices because it is already providing its maximum power to other devices. Under normal operating conditions, the maximum PoE budgets for the switches are 240W for the x240-10GHXm Switch and 370W for the x240-26GHXm Switch.
- ❑ Start a local or remote management session on the switch and enter the `SHOW POWER-INLINE` command. Subtract the Actual Power Consumption value from the Power Allocated value to determine the amount of unallocated power. The switch cannot support the powered device if this value is less than the device's power requirements.

- ❑ If the powered device is PoE or PoE+ (Class 0 to 4), review its documentation to confirm that the device supports Mode A of the IEEE 802.3at standard and that it uses pins 1, 2, 3, and 6 on the RJ-45 port to receive power. Refer to “Wiring Implementation” on page 30.
- ❑ Verify that the powered device conforms with one of the standards in “PoE Standards” on page 28. Powered devices developed before the completion of the standards might not be compatible with the switch.
- ❑ Determine whether the switch has reduced its PoE budget because of an adverse operating condition, such as overheating from a failed fan or poor ventilation. Start a local or remote management session and enter the `SHOW SYSTEM ENVIRONMENT` command to view the status of the fans, power supplies, and internal temperatures.
- ❑ If the powered device is PoE++ (Class 5 or higher), review its documentation to verify that it uses all eight strands (four wire pair-sets) for power in the copper cable.
- ❑ Verify that you are using the appropriate category of twisted-pair cable. Cable requirements for the switch are listed in “Cable Requirements” on page 24.
- ❑ Use the `SHOW POWER-INLINE` command in the management software on the switch to determine whether PoE is enabled on the port. The default setting for PoE is enabled.
- ❑ Use the `SHOW POWER-INLINE` command in the management software on the switch to determine whether the PoE power setting for the port has been reduced to a value below the power requirements of the device.
- ❑ Try connecting the device to a different port on the switch.

Problem 8: The switch functions intermittently.

Solutions: Check the system hardware status through the management software:

- ❑ Use the `SHOW SYSTEM ENVIRONMENT` command in the Privileged Exec mode to verify that the input voltage from the power source to the switch is stable and within the approved operating range. The unit will shut down if the input voltage fluctuates above or below the approved operating range.
- ❑ Use the `SHOW SYSTEM ENVIRONMENT` command in the Privileged Exec mode to verify that the fan is operating correctly.
- ❑ Verify that the location of the switch allows for adequate airflow. The unit will shut down if it overheats.

Appendix A

Technical Specifications

This appendix contains the following sections:

- “Physical Specifications” on page 120
- “Environmental Specifications” on page 123
- “Power Specifications” on page 124
- “RJ-45 Copper Port Pinouts” on page 125
- “RJ-45 Style Serial Console Port Pinouts” on page 127
- “Console Management Cable with DB-9 Female and RJ-45 Connectors” on page 128

Physical Specifications

Dimensions

Table 13 lists the dimensions of the switches.

Table 13. Product Dimensions (WxDxH)

x240-10GHXm	21cm x 34.6cm x 4.3cm (8.27in. x 13.62in. x 1.69in.)
x240-10GTXm	21cm x 27.5cm x 4.3cm (8.27in. x 10.8in. x 1.69in.)
x240-26GHXm	44cm x 29cm x 4.4cm (17.3in. x 11.4in. x 1.73in.)
x240-26GTXm	44cm x 29cm x 4.4cm (17.3in. x 11.4in. x 1.73in.)

Figure 67 illustrates the dimensions of the x240-10GHXm Switch.

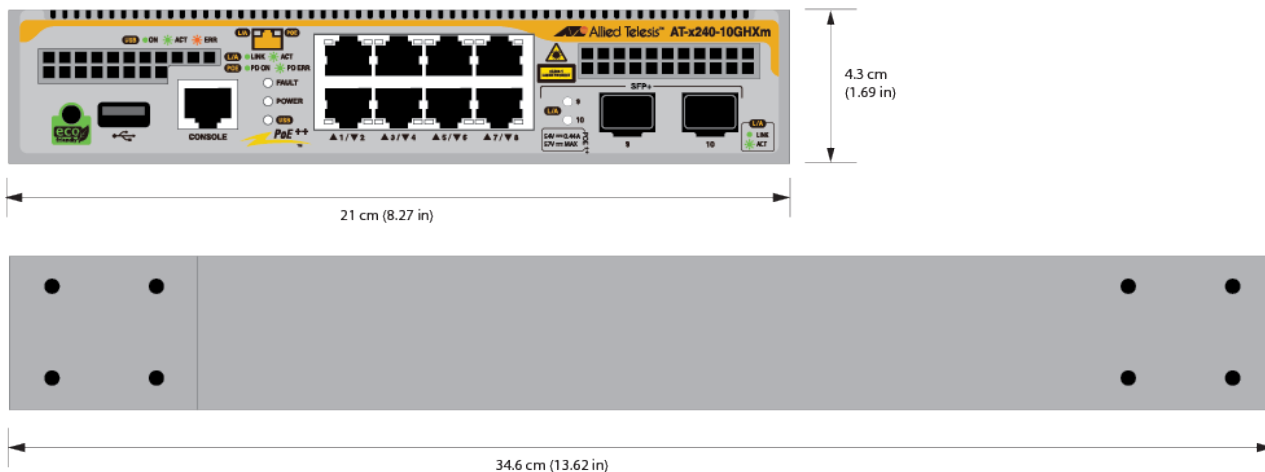

Figure 67. x240-10GHXm Switch Dimensions

Figure 67 illustrates the dimensions of the x240-10GTXm Switch.

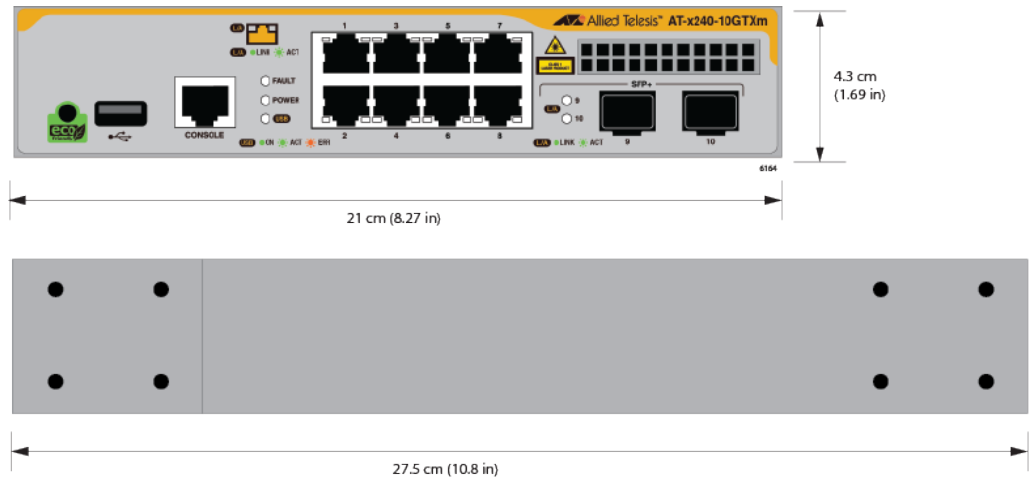

Figure 68. x240-10GTXm Switch Dimensions

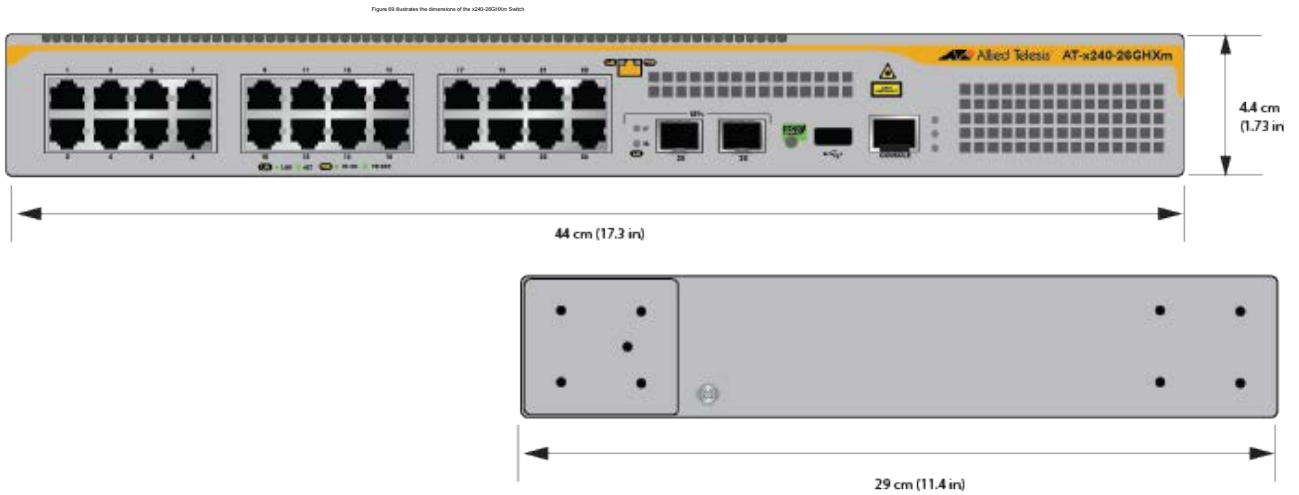

Figure 69. x240-26GHXm and x240-26GTXm Switch Dimensions

Weights

Table 14 lists the weights of the switches.

Table 14. Product Weights

x240-10GHXm	2.7 kg (6 lb)
x240-10GTXm	1.9 kg (4.2 lb)
x240-26GHXm	4.3 kg (9.4 lb)
x240-26GTXm	3.7 kg (8.1 lb)

Ventilation

Table 15 lists the ventilation requirements.

Table 15. Ventilation Requirements

Recommended Minimum Ventilation on All Sides	10 cm (4.0 in)
--	----------------

Note

The enclosure size should be determined by considering multiple factors. This includes the outside ambient temperature, total heat generated from the installed equipment, sealed or unsealed enclosure type, enclosure material, paint color, mounting method (wall, pole, ground, etc.), and sun load. The smaller enclosure size you choose, the higher risk of overheating the product faces.

If the product overheats in an enclosure that was built without taking into account these factors, the warranty of the product might be voided. Consult Allied Telesis when assistance is needed.

Environmental Specifications

Table 16 lists the environmental specifications of the switches.

Table 16. Environmental Specifications

Operating Temperature	0° C to 50° C (32° F to 122° F)
Storage Temperature	-25° C to 70° C (-13° F to 158° F)
Operating Humidity	5% to 90% noncondensing
Storage Humidity	5% to 95% noncondensing
Maximum Operating Altitude	3,000 m (9,842 ft)
Maximum Nonoperating Altitude	4,000 m (13,100 ft)

Power Specifications

This section contains the maximum power consumption values, input voltages, and heat dissipation values.

Maximum Power Consumptions

Table 17 lists the maximum power consumptions for the switches.

Table 17. Maximum Power Consumptions

x240-10GHXm	44 watts
x240-10GTXm	38 watts
x240-26GHXm	86 watts
x240-26GTXm	83 watts

Input Voltages

Table 18 lists the input voltages for the switches.

Table 18. Input Voltages

x240-10GHXm	100-240 VAC, 4.3A maximum, 50/60 Hz
x240-10GTXm	100-240 VAC, 0.9A maximum, 50/60 Hz
x240-26GHXm	100-240 VAC, 6.8A maximum, 50/60 Hz
x240-26GTXm	100-240 VAC, 1.1A maximum, 50/60 Hz

Heat Dissipations

Table 19 lists the heat dissipations for the switches.

Table 19. Heat Dissipations

x240-10GHXm	1137.38 BTU/hr
x240-10GTXm	132.69 BTU/h (140kJ/h)
x240-26GHXm	1895.63 BTU/hr
x240-26GTXm	284.35 BTU/hr

RJ-45 Copper Port Pinouts

Figure 70 illustrates the pin layout of the RJ-45 copper ports on the x240 series switches.

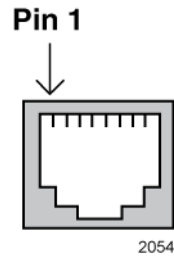

Figure 70. Pin Layout for the RJ-45 Copper Ports (Front View)

Table 20 lists the pin signals at 10 or 100Mbps.

Table 20. Pin Signals on the RJ-45 Copper Ports at 10 or 100Mbps

Pin	MDI Signal	MDI-X Signal
1	TX+	RX+
2	TX-	RX-
3	RX+	TX+
4	Not used	Not used
5	Not used	Not used
6	RX-	TX-
7	Not used	Not used
8	Not used	Not used

Table 21 lists the pin signals at 1/2.5/5G.

Table 21. Pin Signals on the RJ-45 Copper Ports at 1/2.5/5G

Pinout	Pair
1	Pair 1 +
2	Pair 1 -
3	Pair 2 +
4	Pair 3 +
5	Pair 3 -
6	Pair 2 -
7	Pair 4 +
8	Pair 4 -

RJ-45 Style Serial Console Port Pinouts

Table 22 lists the pin signals of the RJ-45 style serial Console port.

Table 22. Pin Signals of the RJ-45 Style Serial Console Port

Pin	Signal
1	Not used.
2	Not used.
3	Transmit Data
4	Ground
5	Ground
6	Receive Data
7	Not used.
8	Not used.

Console Management Cable with DB-9 Female and RJ-45 Connectors

Figure 71 and Table 23 show the pin-outs for a Console port management cable with DB-9 female and RJ-45 connectors.

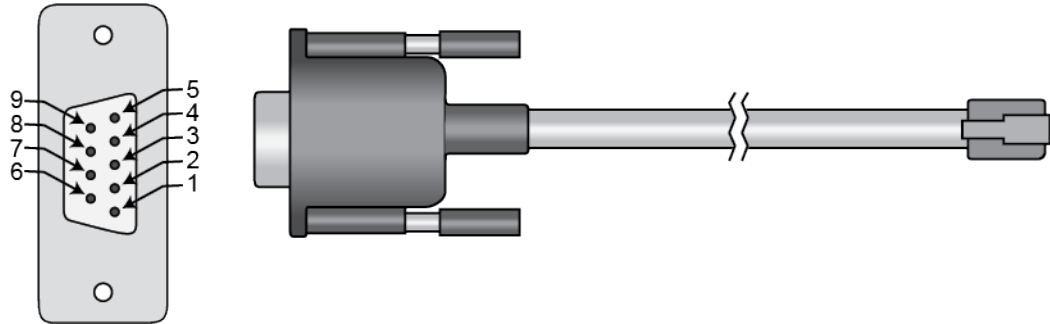

Figure 71. Console Port Management Cable with DB-9 Female and RJ-45 Connectors

Table 23. Pin-outs of Console Port Management Cable with DB-9 Female and RJ-45 Connectors

DB-9 Female Connector Pins	RJ-45 Connector Pins
1	4
2	3
3	6
4	7
5	5
6	2
7	8
8	1
9	NC