

x950 Series

Advanced Layer 3+
AlliedWare Plus™

Switches

AT-x950-28XSQ AT-x950-28XTQm
AT-x950-52XSQ AT-x950-52XTQm

Power Supplies

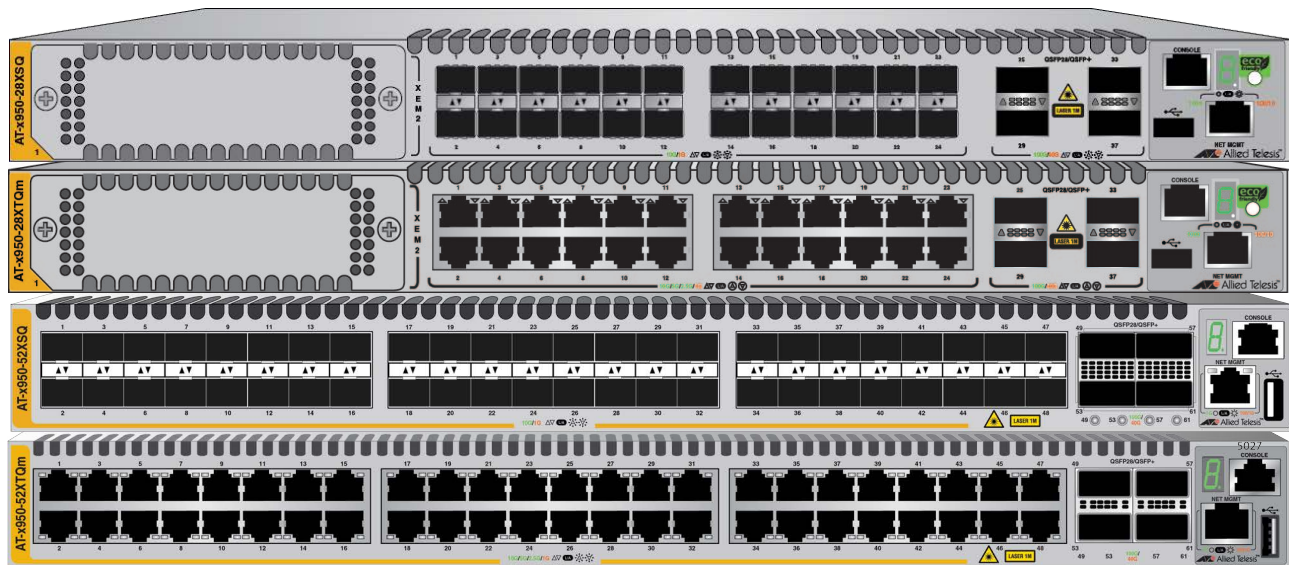
AT-PWR600 AC AT-PWR600R AC
AT-PWR600-80 DC AT-PWR600R-80 DC

Ethernet Line Cards

AT-XEM2-8XSTm
AT-XEM2-12XT AT-XEM2-12XTm
AT-XEM2-12XS AT-XEM2-12XS v2
AT-XEM2-4QS AT-XEM2-1CQ

Fan Modules

AT-FAN05 AT-FAN05R



Installation Guide for Standalone Switches

Copyright © 2025 Allied Telesis, Inc.

All rights reserved. No part of this publication may be reproduced without prior written permission from Allied Telesis, Inc.

Allied Telesis, VCStack, and the Allied Telesis logo are trademarks of Allied Telesis, Incorporated. All other product names, company names, logos or other designations mentioned herein are trademarks or registered trademarks of their respective owners.

Allied Telesis, Inc. reserves the right to make changes in specifications and other information contained in this document without prior written notice. The information provided herein is subject to change without notice. In no event shall Allied Telesis, Inc. be liable for any incidental, special, indirect, or consequential damages whatsoever, including but not limited to lost profits, arising out of or related to this manual or the information contained herein, even if Allied Telesis, Inc. has been advised of, known, or should have known, the possibility of such damages.

Electrical Safety and Emissions Standards

This product meets the following standards.

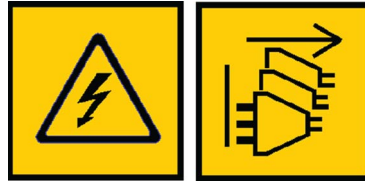
U.S. Federal Communications Commission
<p>Radiated Energy</p> <p>Note: This equipment has been tested and found to comply with the limits for a Class A digital device pursuant to Part 15 of FCC Rules. These limits are designed to provide reasonable protection against harmful interference when the equipment is operated in a commercial environment. This equipment generates, uses, and can radiate radio frequency energy and, if not installed and used in accordance with this instruction manual, may cause harmful interference to radio communications. Operation of this equipment in a residential area is likely to cause harmful interference in which case the user will be required to correct the interference at his own expense.</p> <p>Note: Modifications or changes not expressly approved of by the manufacturer or the FCC, can void your right to operate this equipment.</p>

Industry Canada
<p>This Class A digital apparatus complies with Canadian ICES-003.</p> <p>Cet appareil numérique de la classe A est conforme à la norme NMB-003 du Canada.</p>

Warning: In a domestic environment this product may cause radio interference in which case the user may be required to take adequate measures.

EMI (Emissions)	FCC Class A CISPR 22 Class A EN55032 Class A VCCI Class A ICES-003 Class A RCM
EMC (Immunity)	EN 55035 EN 61000-3-2 EN 61000-3-3
Electrical Safety	UL 60950-1 (CULUS) EN 62368-1 (TUV) EN 60825-1 (TUV)
Laser Safety	EN 60825-1
RoHS	RoHS6

Power Supply Safety Compliance



Warning

This unit has more than one power input. To reduce the risk of electric shock, disconnect all power inputs before servicing unit.

Avertissement

Cet appareil possède plusieurs entrées d'alimentation. Pour réduire le risque de choc électrique, débranchez toutes les entrées d'alimentation avant toute intervention sur l'appareil.

Contents

Preface	15
Document Conventions	16
Translated Safety Statements	17
Chapter 1: Overview	19
x950 Switches	20
Features	22
Hardware Features	22
XEM2 Ethernet Line Cards	23
Management Software and Interfaces	23
Management Methods	23
Management Panel	24
Power Supplies	24
1G SFP and 10G SFP+ Ports on the AT-x950-28XSQ and AT-x950-52XSQ Switches	25
LEDs	26
Copper Ports on the AT-x950-28XTQm and AT-x950-52XTQm Switches	27
Cable Requirements	27
LEDs	28
Ports for 40G QSFP+ and 100G QSFP28 Transceivers, and Breakout Cables	30
QSFP+ Transceivers	30
QSFP28 Transceivers	30
Breakout Cables	30
LEDs	31
Port Numbering for the AT-x950-28XSQ and AT-x950-28XTQm Switches	33
Port Numbering for the AT-x950-52XSQ and AT-x950-52XTQm Switches	34
Management Panel	35
USB Port	36
NET MGMT Ethernet Management Port	39
Console (RS-232) Port	40
Switch ID LED	40
eco-friendly Button	42
Direct Attach Cables	43
AT-PWR600 and AT-PWR600R AC and DC Power Supplies	44
Power Supply Guidelines	49
LEDs	49
AT-FAN05 and AT-FAN05R Fan Modules	52
Designating Ports in the Command Line Interface	54
Base Ports and XEM2 Line Card Ports	55
Examples for the PORT Parameter on Base Ports	56
Examples of the PORT Parameter for the XEM2 Line Card	56
Examples of the PORT Parameter for Breakout Cables	56
Software and Hardware Releases	59
Chapter 2: XEM2 Ethernet Line Cards	61
Overview	62
AT-XEM2-8XSTm Line Card	65
Copper Ports	65
Copper Port LEDs	66
Transceiver Ports	67
Transceiver Port LEDs	68

AT-XEM2-12XT Line Card.....	69
Copper Ports.....	69
LEDs.....	70
AT-XEM2-12XTm Line Card.....	71
Copper Ports.....	71
LEDs.....	72
AT-XEM2-12XS and AT-XEM2-12XS v2 Line Cards.....	73
Transceiver Ports.....	73
Card Versions.....	74
LEDs.....	74
AT-XEM2-4QS Line Card.....	76
Transceiver Ports.....	76
LEDs.....	77
AT-XEM2-1CQ Line Card.....	78
Transceiver Port.....	78
LEDs.....	79
Chapter 3: Beginning the Installation	81
Reviewing Safety Precautions.....	82
Installation Options.....	87
Choosing a Site for the Chassis.....	88
Unpacking the Switch.....	89
Verifying the Accessory Kit.....	93
Unpacking PWR600 AC and DC Power Supplies.....	95
Chapter 4: Installing Power Supplies and XEM2 Line Cards	99
Installing AT-PWR600 and AT-PWR600R AC Power Supplies.....	100
Installing AT-PWR600-80 and AT-PWR600R-80 DC Power Supplies.....	104
Installing XEM2 Ethernet Line Cards.....	106
Chapter 5: Installing the Switch on a Table	111
Chapter 6: Installing the Switch in an Equipment Rack	115
Beginning the Installation.....	116
Required Items.....	116
Switch Orientations in the Equipment Rack.....	116
Removing the Bumper Feet.....	118
Installing the Switch.....	119
Chapter 7: Installing the Switch on a Wall	123
Switch Orientations on a Wall.....	124
Recommended Minimum Wall Area Dimensions.....	125
Plywood Base for a Wall with Wooden Studs.....	127
Installation Guidelines.....	129
Tools and Material.....	130
Installing the Plywood Base.....	131
Installing the Switch on the Plywood Base.....	132
Installing the Switch on a Concrete Wall.....	135
Chapter 8: Installing the Switch in the AT-RKMT-SL01 Sliding Rack	139
Introduction.....	140
Rack Mount Kit Components.....	141
Adjustable Outer Rails.....	141
Inner Rails.....	141
Extension Brackets.....	141
Equipment Rack Requirements.....	143
Reviewing Safety Precautions.....	144
Installation Overview.....	146
Unpacking the Shipping Container.....	147
Installing the Outer Rails on the Equipment Rack.....	149
Installing the Extension Brackets on the Inner Rails.....	151
Measuring the Extension Bracket Lengths.....	151
Assembling the Extension Brackets.....	153

Installing the Inner Rails on the Switch.....	157
Installing the Switch in the Equipment Rack.....	159
Chapter 9: Verifying and Configuring the Switch	163
Powering on AT-PWR600 and AT-PWR600R AC Power Supplies.....	164
Wiring and Powering on AT-PWR600-80 and AT-PWR600R-80 DC Power Supplies.....	167
Connecting the Grounding Wire	167
Connecting the DC Power Wires.....	170
Powering on the DC Power Supplies.....	174
Starting a Local Management Session.....	175
Verifying the Switch with AlliedWare Plus Commands.....	177
Disabling VCStack.....	178
Configuring Ports for 40G QSFP+ and 100G QSFP28 Transceivers, and Breakout Cables	181
Saving Your Changes and Rebooting the Switch.....	183
Chapter 10: Cabling the Networking Ports	185
Cabling Copper Ports	186
Guidelines to Handling Copper and Fiber Optic Transceivers	187
Installing Transceivers.....	188
Installing Direct Attach Cables.....	194
Chapter 11: Replacing Modules	197
Replacing XEM2 Ethernet Line Cards.....	198
Replacing AT-PWR600 and AT-PWR600R AC Power Supplies.....	203
Replacing AT-PWR600-80 and AT-PWR600R-80 DC Power Supplies	208
Replacing AT-FAN05 and AT-FAN05R Modules	211
Removing Fan Modules.....	211
Installing Fan Modules.....	213
Chapter 12: Troubleshooting	217
Appendix A: Technical Specifications	223
Physical Specifications.....	224
Environmental Specifications	228
Power Specifications	229
Certifications.....	240
RJ-45 Copper Port Pinouts	241
RJ-45 Style Serial Console Port Pinouts.....	243

Figures

Figure 1: Front Panels of the AT-x950-28XSQ and AT-x950-28XTQm Switches	20
Figure 2: Front Panels of the AT-x950-52XSQ and AT-x950-52XTQm Switches	21
Figure 3: Rear Panel of the x950 Series.....	21
Figure 4: Link and Activity LEDs for 1G SFP and 10G SFP+ Ports	26
Figure 5: Link and Activity LEDs for the Copper Ports on the AT-x950-28XTQm and AT-x950-52XTQm Switches.....	28
Figure 6: AT-QSFP-4SFP10G-3CU and AT-QSFP-4SFP10G-5CU Copper Breakout Cables	31
Figure 7: LEDs for Ports 25, 29, 33, and 37 on the AT-x950-28XSQ and AT-x950-28XTQm Switches	31
Figure 8: LEDs for Ports 49, 53, 57, and 61 on the AT-x950-52XSQ and AT-x950-52XTQm Switches	31
Figure 9: Management Panel on the AT-x950-28XSQ and AT-x950-28XTQm Switches	35
Figure 10: Management Panel on the AT-x950-52XSQ and AT-x950-52XTQm Switches	35
Figure 11: Switch ID LED with the eco-friendly Mode Disabled	41
Figure 12: Switch ID LED with the eco-friendly Mode Enabled	41
Figure 13: AT-PWR600 Power Supply and AT-FAN05 Fan Module	45
Figure 14: AT-PWR600R AC Power Supply and AT-FAN05R Fan Module	46
Figure 15: AT-PWR600-80 DC Power Supply and AT-FAN05 Fan Module.....	47
Figure 16: AT-PWR600R-80 DC Power Supply and AT-FAN05R Fan Module.....	48
Figure 17: AT-FAN05 and AT-FAN05R Fan Modules	52
Figure 18: PORT Parameter in the Command Line Interface for a Standalone Switch.....	54
Figure 19: Slot Numbers for Port Numbering on AT-x950-28XSQ and AT-x950-28XTQm Switches	55
Figure 20: Copper Breakout Cable	56
Figure 21: XEM2 Ethernet Line Cards.....	62
Figure 22: AT-XEM2-8XSTm Line Card	65
Figure 23: AT-XEM2-12XT Line Card.....	69
Figure 24: AT-XEM2-12XTm Line Card.....	71
Figure 25: AT-XEM2-12XS Line Card	73
Figure 26: AT-XEM2-12XS and AT-XEM2-12XS v2 Line Cards	74
Figure 27: AT-XEM2-4QS Line Card	76
Figure 28: AT-XEM2-1CQ Line Card.....	78
Figure 29: Installation Options.....	87
Figure 30: Removing Accessories	89
Figure 31: Removing the Shipping Box Partition.....	90
Figure 32: Lifting the Switch from the Shipping Box.....	91
Figure 33: Removing the Switch from the Shipping End-caps and Protective Bag	91
Figure 34: Removing the Power Cord and Documents from the Power Supply Shipping Box.....	95
Figure 35: Removing the Partition from the Power Supply Shipping Box.....	96
Figure 36: Removing the Power Supply from the Shipping Box.....	97
Figure 37: Removing the Power Supply from the Shipping End-caps and Protective Bag	97
Figure 38: Removing the Blank Power Supply Panel from Slot PSU B.....	101
Figure 39: Sliding the AT-PWR600 or AT-PWR600R AC Power Supply into the Chassis.....	102
Figure 40: Seating the Power Supply on the Internal Connector.....	103
Figure 41: Sliding the AT-PWR600 DC Power Supply into the Chassis.....	105
Figure 42: Removing the Blank Line Card Cover	106
Figure 43: Removing the XEM2 Line Card from the Anti-static Bag.....	107
Figure 44: Sliding the XEM2 Line Card into the Slot	107
Figure 45: Seating the XEM2 Line Card in the Expansion Slot	108
Figure 46: Tightening the Two Captive Screws on the XEM2 Line Card.....	109
Figure 47: Parts of the Bumper Feet	111
Figure 48: Holes for Bumper Feet	112
Figure 49: Inserting the Rivet Housing into the Bumper Foot.....	112

Figure 50: Placing the Bumper Foot on a Base Corner Hole.....	113
Figure 51: Inserting the Rivet into the Bumper Foot.....	113
Figure 52: Holes for the Equipment Rack Brackets on the AT-x950-28XSQ and AT-x950-28XTQm Switches.....	116
Figure 53: Holes for the Equipment Rack Brackets on the AT-x950-52XSQ and AT-x950-52XTQm Switches.....	116
Figure 54: Switch Orientations in an Equipment Rack.....	117
Figure 55: Removing the Bumper Feet.....	118
Figure 56: Attaching the Equipment Rack Brackets.....	120
Figure 57: Installing the Switch in an Equipment Rack.....	120
Figure 58: Positions of the Switch on the Wall.....	124
Figure 59: Minimum Wall Area Dimensions with the Front Panel on the Left.....	125
Figure 60: Minimum Wall Area Dimensions with the Front Panel on the Right.....	126
Figure 61: Switch on the Wall with a Plywood Base.....	127
Figure 62: Steps to Installing the Switch with a Plywood Base.....	128
Figure 63: Installing the Brackets to the Switch for Wall Installation.....	132
Figure 64: Attaching the Switch to the Plywood Base.....	133
Figure 65: Marking the Locations of the Bracket Holes on a Concrete Wall.....	136
Figure 66: Installing the Switch on a Concrete Wall.....	137
Figure 67: Outer Rails.....	141
Figure 68: Inner Rails.....	141
Figure 69: Extension Brackets.....	142
Figure 70: Shipping Container Contents.....	147
Figure 71: FRONT and REAR Labels on the Outer Rails.....	149
Figure 72: Installing the Outer Rails on the Equipment Rack.....	150
Figure 73: Extension Brackets.....	151
Figure 74: Example of a Switch Recessed in an Equipment Rack.....	151
Figure 75: Inserting an Inner Rail into an Outer Rail.....	152
Figure 76: Example of Positioning the Inner Rail.....	152
Figure 77: Measuring for the Extension Brackets.....	152
Figure 78: Removing the Inner Rail.....	153
Figure 79: Extension Bracket Parts.....	153
Figure 80: Extension Bracket Configurations.....	154
Figure 81: Example of Attaching the Extension Brackets to the Inner Rails.....	155
Figure 82: Testing the Inner Rails with the Extension Brackets.....	156
Figure 83: Verifying the Length of the Extension Bracket.....	156
Figure 84: Inner Rail Screw Holes for the AT-x950-28XSQ and AT-x950-28XTQm Switches.....	157
Figure 85: Inner Rail Screw Holes for the AT-x950-52XSQ and AT-x950-52XTQm Switches.....	157
Figure 86: Attaching the Inner Rails to the x950 Switch.....	158
Figure 87: Sliding the Inner Rails on the Switch into the Outer Rails.....	159
Figure 88: Affixing the Warning Labels.....	160
Figure 89: Tightening the Two Screws on the Fixed Brackets.....	160
Figure 90: Tightening the Screws on the Outer Rails.....	161
Figure 91: Connecting the AC Power Cord.....	165
Figure 92: Securing the Power Cord with the Restraining Strap.....	165
Figure 93: Connecting the Power Cord to an AC Power Source.....	166
Figure 94: Stripping the Grounding Wire.....	168
Figure 95: Loosening the Screw for the Panel.....	168
Figure 96: Accessing the Connectors.....	169
Figure 97: Loosening the Ground Screw.....	169
Figure 98: Wrapping the Grounding Wire and Tightening the Screw.....	170
Figure 99: Stripping the Power Wire.....	170
Figure 100: Wrapping the Wire Strands.....	171
Figure 101: Loosening the Screw for the Negative (-).....	171
Figure 102: Tightening the Screw for the Negative (-).....	172
Figure 103: Loosening the Screw for the Negative (+).....	172
Figure 104: Tightening the Screw for the Negative (+).....	173
Figure 105: Placing the Cover Panel.....	173
Figure 106: Tightening the Screw for the Cover Panel.....	174
Figure 107: Connecting the Management Cable to the Console RS-232 Port.....	175
Figure 108: User Exec Mode Prompt.....	176
Figure 109: SHOW STACK Command.....	178

Figure 110: Moving to the Global Configuration Mode	179
Figure 111: Confirmation Prompt for the NO STACK ENABLE Command	179
Figure 112: Returning to the Privileged Exec Mode	179
Figure 113: Saving the Changes with the WRITE Command.....	180
Figure 114: Returning to the Privileged Exec Mode with the EXIT Command	183
Figure 115: Saving Changes with the WRITE Command.....	183
Figure 116: Handle on 40G and 100G Transceivers	187
Figure 117: AT-SP10T Transceivers	189
Figure 118: Installing an SFP or SFP+ Transceiver	191
Figure 119: Installing 40Gbps Fiber Optic Transceivers in the AT-XEM2-4QS Line Card	192
Figure 120: Installing 100Gbps QSFP28 Transceivers in Base Ports 25 to 37	192
Figure 121: Installing 100Gbps QSFP28 Transceivers in the AT-XEM2-1CQ Line Card	193
Figure 122: Installing AT-SP10TW Direct Attach Cables	194
Figure 123: Attaching QSFP28 Cables	195
Figure 124: Loosening the Screws on the Ethernet Line Card	199
Figure 125: Disconnecting an Ethernet Line Card from the Switch	200
Figure 126: Sliding an Ethernet Line Card from the Switch.....	200
Figure 127: Placing the XEM2 Line Card in its Anti-static Bag.....	201
Figure 128: Installing the Line Card Blank Cover	201
Figure 129: Tightening the Two Screws on the Line Card Blank Panel	202
Figure 130: Disconnecting the AC Power Cord from the Power Source	203
Figure 131: Opening the Restraining Strap on the Power Supply	204
Figure 132: Disconnecting the Power Cord from the Power Supply.....	204
Figure 133: Removing the Power Supply	205
Figure 134: Removing a Power Supply	206
Figure 135: Installing the Blank Power Supply Cover.....	207
Figure 136: Loosening the Screw for the Panel.....	208
Figure 137: Accessing the Connecting Screws	209
Figure 138: Front Panel of the PWR600 DC Power Supply	209
Figure 139: Removing a DC Power Supply	210
Figure 140: Loosening the Screws on the Fan Module	211
Figure 141: Disconnecting the Fan Module from the Switch	212
Figure 142: Sliding the Fan Module from the Switch	212
Figure 143: Removing the Fan Module from the Shipping Container.....	213
Figure 144: Aligning the AT-FAN05 Module in the Switch Slot	214
Figure 145: Seating the Fan Module on the Internal Connector.....	214
Figure 146: Tightening the Two Captive Screws on the Fan Module	215
Figure 147: Switch Width and Height	224
Figure 148: Switch Depth and Locations of Bracket Holes for the AT-x950-28XSQ and AT-x950-28XTQm Switches	225
Figure 149: Switch Depth and Bracket Holes for AT-x950-52XSQ and AT-x950-52XTQm Switches.....	226
Figure 150: Pin Layout (Front View) of Copper Ports.....	241

Tables

Table 1: x950 Switch Components	20
Table 2: Link and Activity Status LEDs for 1G SFP and 10G SFP+ Ports	26
Table 3: Copper Ports on AT-x950-28XTQm and AT-x950-52XTQm Switches	27
Table 4: Link and Activity LEDs for Copper Ports on AT-x950-28XTQm and AT-x950-52XTQm Switches	28
Table 5: Ports for QSFP+ and QSFP28 Transceivers, and 4x10G Breakout Cables	30
Table 6: Link and Activity Status LEDs for 40G QSFP+ and 100G QSFP28 Transceivers	32
Table 7: Link and Activity Status LEDs for 10G Breakout Cables	32
Table 8: Port Numbering for Ports 25 to 37	33
Table 9: Port Numbering for Ports 49, 53, 57, and 61	34
Table 10: Examples of Switch Features that Support the USB Port	36
Table 11: NET MGMT Port LED	40
Table 12: Optional Direct Attach Cables	43
Table 13: AT-PWR600 and AT-PWR600R AC and DC Power Supplies	44
Table 14: LEDs on the AT-PWR600 and AT-PWR600R AC Power Supplies	49
Table 15: LEDs on the AT-PWR600-80 and AT-PWR600R-80 DC Power Supplies	50
Table 16: Fan Modules and Power Supplies	52
Table 17: PORT Parameter Format for a Standalone Switch	54
Table 18: Port Numbers with and without Breakout Cables on the AT-x950-28XTQm and AT-x950-28XSQ Switches	57
Table 19: Port Numbers with and without Breakout Cables on the AT-x950-52XTQm and AT-x950-52XSQ Switches	57
Table 20: Port Numbers with and without Breakout Cables on the AT-XEM2-4QS Line Card	57
Table 21: Software and Hardware Releases	59
Table 22: XEM2 Ethernet Line Cards	63
Table 23: Copper Ports on the AT-XEM2-8XSTm Line Card	65
Table 24: Link and Activity LEDs for the Copper Ports on the AT-XEM2-8XSTm Line Card	66
Table 25: Link and Activity LEDs for the SFP Ports on the AT-XEM2-8XSTm Line Card	68
Table 26: Copper Ports on the AT-XEM2-12XT Line Card	69
Table 27: Port Link and Activity LEDs on the AT-XEM2-12XT Line Card	70
Table 28: Copper Ports on the AT-XEM2-12XTm Line Card	71
Table 29: Link and Activity LEDs on the AT-XEM2-12XTm Line Card	72
Table 30: Port Link and Activity LEDs on the AT-XEM2-12XS Line Card	74
Table 31: Port Link and Activity Status LEDs on the AT-XEM2-4QS Line Card	77
Table 32: Link and Activity Status LEDs for 10G Breakout Cables	77
Table 33: Port Link and Activity Status LED on the AT-XEM2-1CQ Line Card	79
Table 34: Accessory Kit	93
Table 35: Additional Accessory Kit for the AT-x950-52XSQ and AT-x950-52XTQm Switches	94
Table 36: Extension Bracket Parts	153
Table 37: Transceivers for the Base Transceiver Slots	188
Table 38: Transceivers for the XEM2 Ethernet Line Cards	189
Table 39: Product Dimensions	224
Table 40: Product Weights	227
Table 41: Ventilation Requirements	227
Table 42: Environmental Specifications	228
Table 43: Maximum Power Consumptions (Watts) for the AT-x950-28XSQ Switch	229
Table 44: Maximum Power Consumptions (Watts) for the AT-x950-28XTQm Switch	231
Table 45: Maximum Power Consumptions (Watts) for the AT-x950-52XSQ Switch	233
Table 46: Maximum Power Consumptions (Watts) for the AT-x950-52XTQm Switch	233
Table 47: Typical Power Savings in eco-friendly Mode (Watts) for the AT-x950-28XSQ Switch	234
Table 48: Typical Power Savings in eco-friendly Mode (Watts) for the AT-x950-28XTQm Switch	234
Table 49: Input Voltages	235

Tables

Table 50: Maximum Power Supply Efficiency (Based on 100V Input Voltage)	235
Table 51: Heat Dissipations for the AT-x950-28XSQ Switch	235
Table 52: Heat Dissipations for the AT-x950-28XTQm Switch	237
Table 53: Heat Dissipations for the AT-x950-52XSQ Switch	239
Table 54: Heat Dissipations for the AT-x950-52XTQm Switch	239
Table 55: Product Certifications	240
Table 56: Pin Signals on RJ-45 Copper Ports at 100M	241
Table 57: Pin Signals on Copper Ports at 1G/2.5G/5G/10G	242
Table 58: RJ-45 Style Serial Console Port Pin Signals	243

Preface

This guide contains the installation instructions for the x950 Series of advanced Layer 3+ Ethernet switches. The instructions explain how to install the units as standalone switches. For instructions on how to build a stack of switches with the VCStack feature, refer to the *x950 Series Installation Guide for Virtual Chassis Stacking*.

This preface contains the following sections:

- “Document Conventions” on page 16
- “Translated Safety Statements” on page 17

Document Conventions

This document uses the following conventions:

Note

Notes provide additional information.



Caution

Cautions inform you that performing or omitting a specific action may result in equipment damage or loss of data.



Warning


Warnings inform you that performing or omitting a specific action may result in bodily injury.




Warning

Laser warnings inform you that an eye or skin hazard exists due to the presence of a Class 1 laser device.


Translated Safety Statements

Important: The  indicates that translations of the safety statement are available in the PDF document **Translated Safety Statements** posted on the Allied Telesis website at alliedtelesis.com/library/search.


Übersetzte Sicherheitserklärungen:

Wichtig: Das  zeigt an, dass Übersetzungen der Sicherheitserklärung in den PDF-**Translated Safety Statements** auf der Allied Telesis-Website unter alliedtelesis.com/us/en/library/search verfügbar sind.


Declaraciones de seguridad traducidas:

Importante: El  indica que las traducciones de la declaración de seguridad están disponibles en las **Translated Safety Statements** en PDF publicadas en el sitio web de Allied Telesis en alliedtelesis.com/us/en/library/search.


Consignes de sécurité traduites:

Important: Le symbole  indique que les traductions de la déclaration de sécurité sont disponibles dans le PDF **Translated Safety Statements** publiées sur le site Web de Allied Telesis à l'adresse alliedtelesis.com/us/en/library/search.

Dichiarazioni di sicurezza tradotte:

Importante:  indica che le traduzioni della dichiarazione di sicurezza sono disponibili nelle **Translated Safety Statements** in PDF pubblicate sul sito Web di Allied Telesis all'indirizzo alliedtelesis.com/us/en/library/search.

Översatta säkerhetsförklaringar:

Viktig:  anger att översättningar av säkerhetsförklaringen finns tillgängliga i PDF-dokumentet **Translated Safety Statements** som publicerats på Allied Telesis webbplats på alliedtelesis.com/us/en/library/search.

Chapter 1

Overview

The chapter contains the following sections:

- ❑ “x950 Switches” on page 20
- ❑ “Features” on page 22
- ❑ “1G SFP and 10G SFP+ Ports on the AT-x950-28XSQ and AT-x950-52XSQ Switches” on page 25
- ❑ “Copper Ports on the AT-x950-28XTQm and AT-x950-52XTQm Switches” on page 27
- ❑ “Ports for 40G QSFP+ and 100G QSFP28 Transceivers, and Breakout Cables” on page 30
- ❑ “Management Panel” on page 35
- ❑ “Direct Attach Cables” on page 43
- ❑ “AT-PWR600 and AT-PWR600R AC and DC Power Supplies” on page 44
- ❑ “AT-FAN05 and AT-FAN05R Fan Modules” on page 52
- ❑ “Designating Ports in the Command Line Interface” on page 54
- ❑ “Software and Hardware Releases” on page 59

x950 Switches

Table 1 lists the hardware components for the x950 Switches.

Table 1. x950 Switch Components

Model	SFP/SFP+ Ports	1M/1G/2.5G/5G/10G Copper Ports	QSFP+/QSFP28 Ports for 40G/100G Transceivers and 10G Breakout Cables	XEM2 Line Card	eco-friendly Button
AT-x950-28XSQ	1 to 24	N/A	25, 29, 33, 37	Supported	Supported
AT-x950-28XTQm	N/A	1 to 24	25, 29, 33, 37	Supported	Supported
AT-x950-52XSQ	1 to 48	N/A	49, 53, 57, 61	N/A	N/A
AT-x950-52XTQm	N/A	1 to 48	49, 53, 57, 61	N/A	N/A

Figure 1 shows the front panels of the AT-x950-28XSQ and AT-x950-28XTQm Switches.

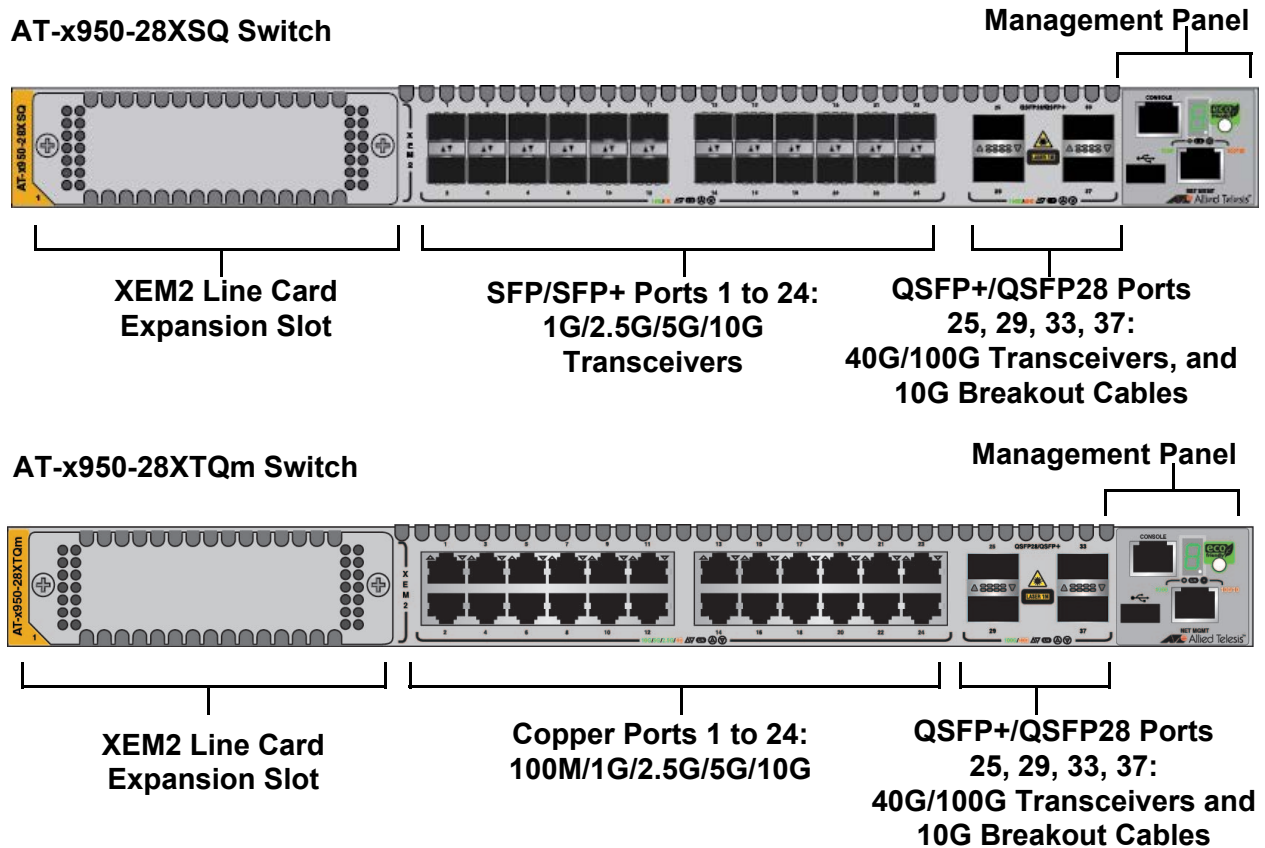
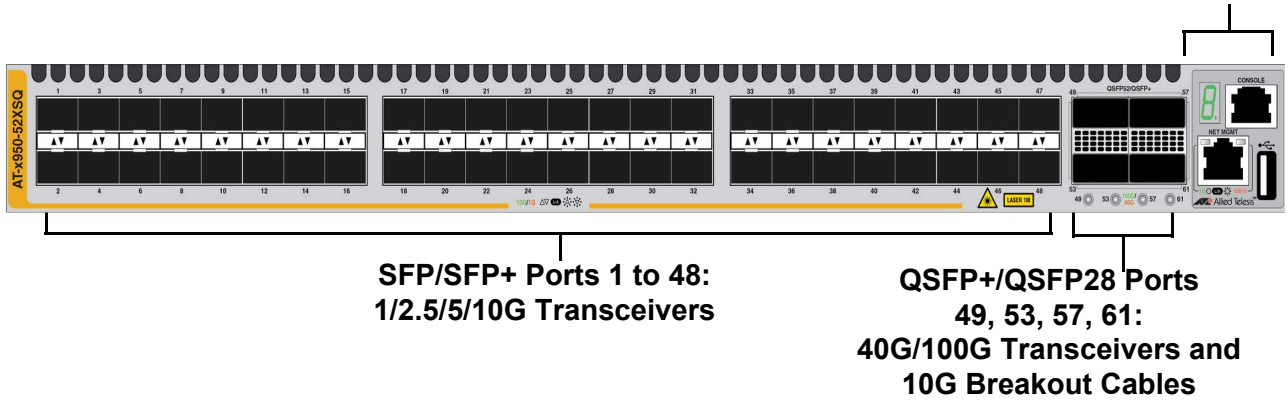


Figure 1. Front Panels of the AT-x950-28XSQ and AT-x950-28XTQm Switches

Figure 2 shows the front panels of the AT-x950-52XSQ and AT-x950-52XTQm Switches.

AT-x950-52XSQ Switch

Management Panel



AT-x950-52XTQm Switch

Management Panel

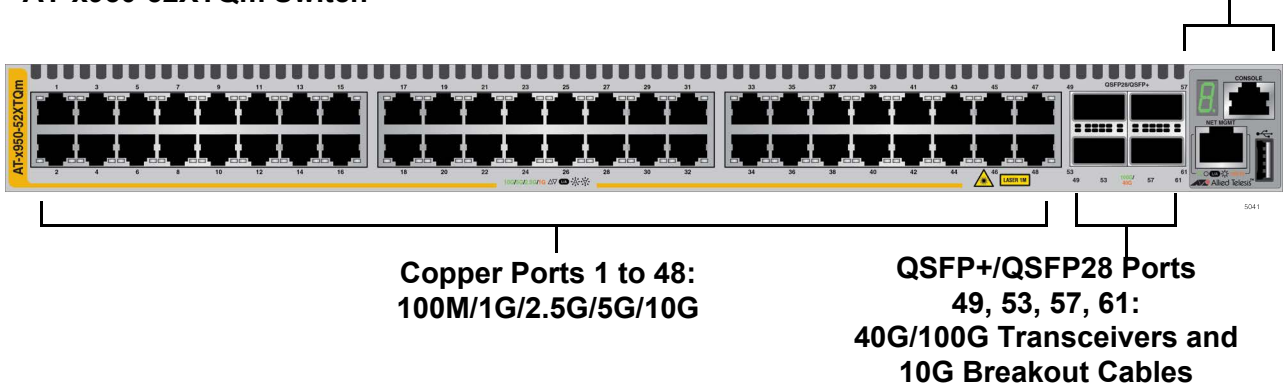


Figure 2. Front Panels of the AT-x950-52XSQ and AT-x950-52XTQm Switches

The rear panel of x950 Switches is shown in Figure 3.

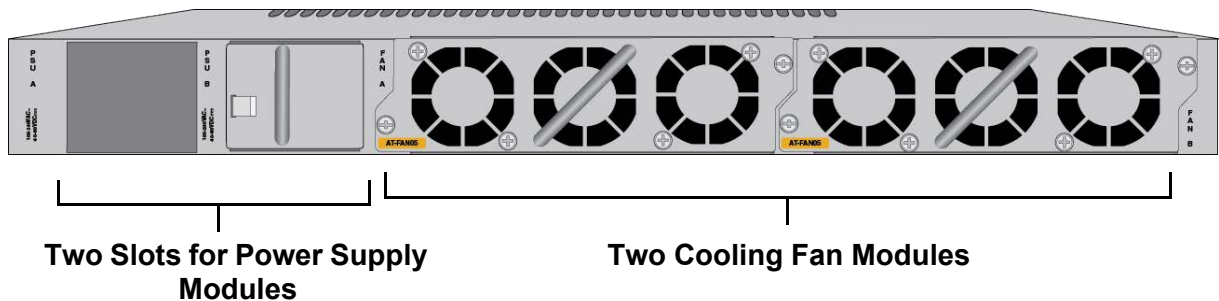


Figure 3. Rear Panel of the x950 Series

Features

The main hardware features of the x950 Switches are listed here.

Hardware Features

The switch has the following hardware features:

- ❑ 1RU height
- ❑ 24 ports on the AT-x950-28XSQ Switch for 1G/2.5G/5G/10G SFP/SFP+ transceivers. Refer to “1G SFP and 10G SFP+ Ports on the AT-x950-28XSQ and AT-x950-52XSQ Switches” on page 25.
- ❑ 24 copper ports on the AT-x950-28XTQm Switch with speeds of 100M/1G/2.5G/5G/10G. Refer to “Copper Ports on the AT-x950-28XTQm and AT-x950-52XTQm Switches” on page 27.
- ❑ 48 ports on the AT-x950-52XSQ Switch for 1G/2.5G/5G/10G SFP/SFP+ transceivers. Refer to “1G SFP and 10G SFP+ Ports on the AT-x950-28XSQ and AT-x950-52XSQ Switches” on page 25.
- ❑ 48 copper ports on the AT-x950-52XTQm Switch with speeds of 100M/1G/2.5G/5G/10G. Refer to “Copper Ports on the AT-x950-28XTQm and AT-x950-52XTQm Switches” on page 27.
- ❑ Four ports for 40G QSFP+ or 100G QSFP28 transceivers, or 10G breakout cables. Refer to “Ports for 40G QSFP+ and 100G QSFP28 Transceivers, and Breakout Cables” on page 30.
- ❑ One expansion slot on the AT-x950-28XSQ and AT-x950-28XTQm Switches for an optional XEM2 Line Card. Refer to Chapter 2, “XEM2 Ethernet Line Cards” on page 61.
- ❑ The switches support two power supplies for primary and redundant power. Refer to “AT-PWR600 and AT-PWR600R AC and DC Power Supplies” on page 44.
- ❑ The units come with two pre-installed fan modules. Refer to “AT-FAN05 and AT-FAN05R Fan Modules” on page 52.
- ❑ The switches come with brackets for standard 19-inch equipment racks or wall installation.
- ❑ The XEM2 Line Cards, power supplies, and fan modules are hot-swappable.

XEM2 Ethernet Line Cards

The XEM2 Line Cards for the AT-x950-28XSQ and AT-x950-28XTQm Switches are listed here:

- ❑ AT-XEM2-8XSTm Card features four 100M/1G/2.5G/5G/10G copper ports with RJ-45 connectors and four ports for 1G SFP or 10G SFP+ transceivers. Refer to “AT-XEM2-8XSTm Line Card” on page 65.
- ❑ AT-XEM2-12XT Card features 12 copper ports with speeds of 100M/ 1G/10G, and RJ-45 connectors. Refer to “AT-XEM2-12XT Line Card” on page 69.
- ❑ AT-XEM2-12XTm Card features 12 copper ports with speeds of 1G/2.5G/5G/10G, and RJ-45 connectors. Refer to “AT-XEM2-12XTm Line Card” on page 71.
- ❑ AT-XEM2-12XS and AT-XEM2-12XS v2 Cards feature 12 ports for 1G/10G SFP/SFP+ transceivers. Refer to “AT-XEM2-12XS and AT-XEM2-12XS v2 Line Cards” on page 73.
- ❑ AT-XEM2-4QS Card features four ports for 40G QSFP+ transceivers. Refer to “AT-XEM2-4QS Line Card” on page 76.
- ❑ AT-XEM2-1CQ Card features one port for an 100G QSFP28 transceiver. Refer to “AT-XEM2-1CQ Line Card” on page 78.

Line cards are ordered separately. Refer to the product data sheet on the Allied Telesis web site for a list of approved transceivers.

Management Software and Interfaces

Here are the management software and interfaces:

- ❑ AlliedWare Plus management software.
- ❑ Command line interface, available locally through the Console port or remotely over the network.

The AlliedWare Plus management software comes pre-installed on the switch.

Management Methods

You can manage the switch as follows:

- ❑ Command line interface accessed locally through the Console port or remotely using Telnet or Secure Shell.
- ❑ Remote access with SNMPv1, v2c, or v3.

Management Panel

The management panel has the following features:

- ❑ Console RS-232 port for local management (no IP address required).
- ❑ USB 2.0 port for storing backup copies of system configuration files, updating management software, and other management functions.
- ❑ An eco-friendly button for turning off the port and system LEDs to reduce power consumption.

Note

The AT-x950-52XSQ and AT-x950-52XTQm Switches do not have the eco-friendly button; however, the eco-friendly mode can be turned on or off with the ECOFRIENDLY LED or NO ECOFRIENDLY LED command in the Command Line Interface.

- ❑ Network management port for initial configuration and maintenance access to the chassis.

Power Supplies

The switch has slots for two power supplies on the back panel. The switch can be powered by a single power supply. Adding a second power supply provides power redundancy. Power supplies are ordered separately. Refer to “AT-PWR600 and AT-PWR600R AC and DC Power Supplies” on page 44.

1G SFP and 10G SFP+ Ports on the AT-x950-28XSQ and AT-x950-52XSQ Switches

Ports 1 to 24 on the AT-x950-28XSQ Switch and ports 1 to 48 on the AT-x950-52XSQ Switch support 1G SFP and 10G SFP+ transceivers. Here are examples of 1G SFP transceivers:

- ❑ SPSX and LR short and long distance transceivers using multi-mode or single mode fiber optic cable.
- ❑ SPTX transceiver series with RJ-45 connector for copper cable.
- ❑ SPEX transceivers with a maximum distance of two kilometers with multi-mode fiber optic cable.

Here are examples of SFP+ 10G transceivers:

- ❑ SP10SR, LR, ER and ZR series of short or long distance transceivers using multi-mode or single mode fiber optic cable.
- ❑ SP10TW series of direct attach cables in lengths up to seven meters.
- ❑ SP10BD series of bidirectional transceivers for single mode fiber optic cable with maximum distances of 10 to 40 kilometers
- ❑ SP10T transceiver with RJ-45 connector for links up to 20 meters at 10G with Category 6a copper cable, or 100 meters at 1G.
- ❑ SP10LRM Long Reach Multimode transceiver for OM1 multi-mode fiber optic links up to 220 meters.
- ❑ SP10TM transceiver with RJ-45 connector for speeds of 1G/2.5G/5G/10G.

Note

Industrial (-40 to 85° C) and extended (-40 to 105° C) temperature transceivers are available.

Here are transceiver guidelines:

- ❑ The ports do not support 100M transceivers.
- ❑ They support full-duplex mode only.
- ❑ You can set the port speeds with Auto-Negotiation or manually. The default is Auto-Negotiation.

Transceivers must be purchased separately. For a list of supported transceivers, refer to the product data sheet on the Allied Telesis web site.

LEDs The LEDs are located between the ports. Each port has one LED. Refer to Figure 4.

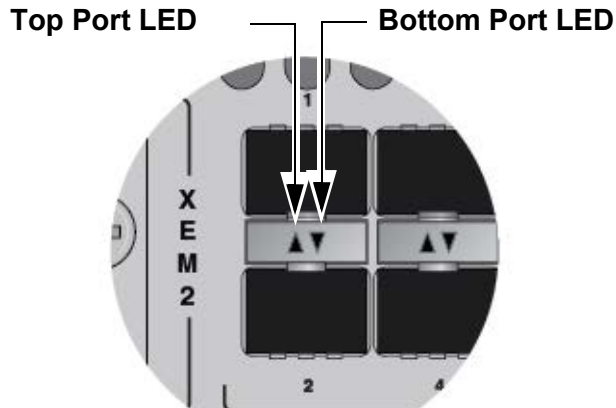


Figure 4. Link and Activity LEDs for 1G SFP and 10G SFP+ Ports

The LEDs display link and activity status. The possible LED states are described in Table 2.

Table 2. Link and Activity Status LEDs for 1G SFP and 10G SFP+ Ports

State	Description
Solid Green	The transceiver has established a 10G link to a network device.
Flashing Green	The transceiver is transmitting or receiving data in 10G.
Solid Amber	The transceiver has established a 1G link to a network device.
Flashing Amber	The transceiver is transmitting or receiving data in 1G.
Off	<p>Possible causes of this state are listed here:</p> <ul style="list-style-type: none"> - The transceiver slot is empty. - The transceiver has not established a link to a network device. - The LEDs are turned off. To turn on the LEDs, use the eco-friendly button in the management panel or the NO ECOFRIENDLY LED command in the command line interface. <hr/> <p>Note The AT-x950-52XSQ and AT-x950-52XTQm Switches do not have the eco-friendly button.</p> <hr/>

Copper Ports on the AT-x950-28XTQm and AT-x950-52XTQm Switches

The specifications for copper ports 1 to 24 on the AT-x950-28XTQm Switch and ports 1 to 48 on the AT-x950-52XTQm Switch are listed in Table 3.

Table 3. Copper Ports on AT-x950-28XTQm and AT-x950-52XTQm Switches

Specification	Description
Port Speed	<p>Here are the supported speeds:</p> <ul style="list-style-type: none"> - 100M - 1G/2.5G/5G/10G <p>Here are the guidelines to setting port speeds:</p> <ul style="list-style-type: none"> - 100M can be set manually or with Auto-Negotiation. - 1/2.5/5/10G require Auto-Negotiation. <p>The default port setting is Auto-Negotiation.</p>
Duplex Mode	Full-duplex only
Maximum Distance	100 meters (328 feet)
Connector	8-pin RJ-45

Note

The network devices connected to the ports must be IEEE 802.3u compliant.

Cable Requirements

The minimum cable requirements are listed here:

- 100M - Standard TIA/EIA 568-B-compliant Category 3 unshielded cabling.
- 1/2.5/5G - Standard TIA/EIA 568-A-compliant Category 5 or TIA/EIA 568-B-compliant Enhanced Category 5 (Cat 5e) unshielded cabling.
- 10G -Standard TIA/EIA 568-C-compliant Category 6a unshielded cabling.

LEDs This section explains the LEDs for the 100M/1G/2.5G/5G/10G copper ports on the AT-x950-28XTQm and AT-x950-52XTQm Switches. Each port has one LED that displays link and activity information. The LEDs are shown in Figure 5.

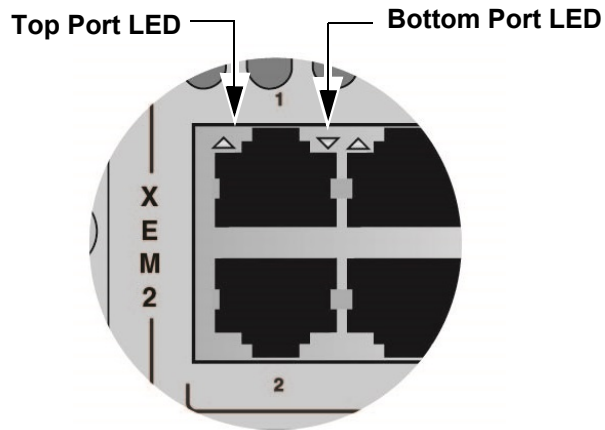


Figure 5. Link and Activity LEDs for the Copper Ports on the AT-x950-28XTQm and AT-x950-52XTQm Switches

The states of the link and activity LEDs are described in Table 4.

Table 4. Link and Activity LEDs for Copper Ports on AT-x950-28XTQm and AT-x950-52XTQm Switches

State	Description
Solid Green	The port has established a 2.5G, 5G, or 10G link to a network device.
Flashing Green	The port is transmitting or receiving data at 2.5G, 5G, or 10G.
Solid Amber	The port has established a 100M or 1G link to a network device.
Flashing Amber	The port is transmitting or receiving data at 100M or 1G.

Table 4. Link and Activity LEDs for Copper Ports on AT-x950-28XTQm and AT-x950-52XTQm Switches (Continued)

State	Description
Off	<p>Possible causes of this state are listed here:</p> <ul style="list-style-type: none"> - The port has not established a link with another network device. - The LEDs are turned off. To turn on the LEDs, use the eco-friendly button in the management panel or the NO ECOFRIENDLY LED command in the command line interface. <hr/> <p>Note The AT-x950-52XSQ and AT-x950-52XTQm Switches do not have the eco-friendly button.</p>

Ports for 40G QSFP+ and 100G QSFP28 Transceivers, and Breakout Cables

The x950 Switches have four ports that support the transceivers and cables listed in Table 5.

Table 5. Ports for QSFP+ and QSFP28 Transceivers, and 4x10G Breakout Cables

Switch	Port Numbers	40G QSFP+ Transceivers	100G QSFP28 Transceivers	4x10G Breakout Cables
AT-x950-28XSQ	25, 29, 33, 37	Yes	Yes	Yes
AT-x950-28XTQm	25, 29, 33, 37	Yes	Yes	Yes
AT-x950-52XSQ	49, 53, 57, 61	Yes	Yes	Yes
AT-x950-52XTQm	49, 53, 57, 61	Yes	Yes	Yes

QSFP+ Transceivers

The ports support the following 40G QSFP+ transceivers:

- ❑ AT-QSFPSR4 transceiver - Maximum operating distance of 150m (492 ft) with 12-strand OM4 fiber optic cable.
- ❑ AT-QSFPLR4 transceiver - Maximum operating distance of 2m (6.6 ft) to 10km (6.2 mi) with single-mode fiber optic cable.
- ❑ AT-QSFP1CU and AT-QSFP3CU direct attach cables - Lengths of 1 and 3 meters, respectively.

QSFP28 Transceivers

The ports support the following 100G QSFP28 transceivers:

- ❑ AT-QSFP28SR4 transceiver - Maximum operating distance of 70m (230 ft) or 100m (328 ft) with 12-strand OM3 or OM4 fiber optic cable, respectively. Requires an MPO pluggable optical connector.
- ❑ AT-QSFP28LR4 transceiver - Operating range of 2m (6.6 ft) to 10km (6.2 mi) with single-mode fiber optic cable. Requires a duplex LC connector.
- ❑ AT-QSFP28-1CU and AT-QSFP28-3CU direct attach cables - Lengths of one and three meters, respectively.

Breakout Cables

The ports also support copper and fiber optic break-out cables. The cables convert the ports from single 40G ports to four SFP+ 10G ports. The model names of the copper cables are AT-QSFP-4SFP10G-3CU and AT-QSFP-4SFP10G-5CU. They come in lengths of 3 and 5 meters, respectively. Refer to Figure 6 on page 31.



Figure 6. AT-QSFP-4SFP10G-3CU and AT-QSFP-4SFP10G-5CU Copper Breakout Cables

LEDs The ports for the QSFP28 and QSFP+ transceivers and breakout cables have one link and activity status LED. Refer to Figure 7.

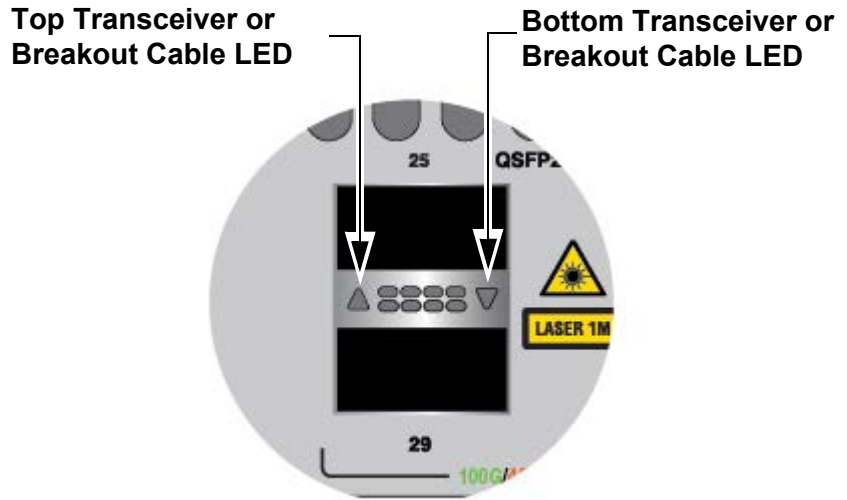


Figure 7. LEDs for Ports 25, 29, 33, and 37 on the AT-x950-28XSQ and AT-x950-28XTQm Switches

Ports 49, 53, 57, and 61 on the AT-x950-52XSQ and AT-x950-52XTQm Switches have one link and activity status LED. Refer to Figure 8.

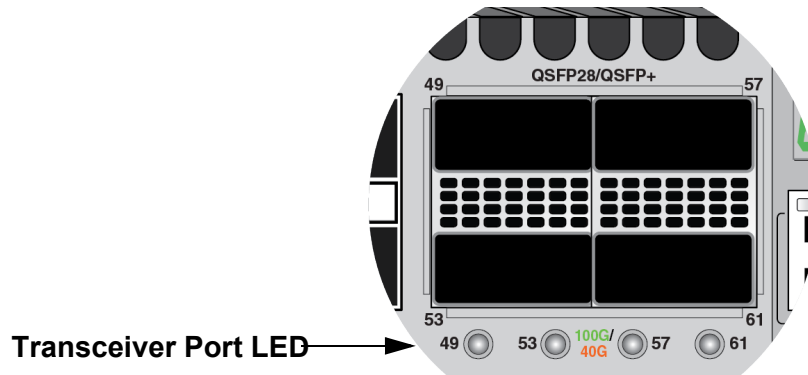


Figure 8. LEDs for Ports 49, 53, 57, and 61 on the AT-x950-52XSQ and AT-x950-52XTQm Switches

LEDs for 40G QSFP+ and 100G QSFP28 Transceivers

The states of the LEDs for 40G QSFP+ and 100G QSFP28 transceivers are defined in Table 6.

Table 6. Link and Activity Status LEDs for 40G QSFP+ and 100G QSFP28 Transceivers

State	Description
Solid Green	The transceiver has established a 100G link to a network device.
Flashing Green	The transceiver is transmitting or receiving data at 100G.
Solid Amber	The transceiver has established a 40G link to a network device.
Flashing Amber	The transceiver is transmitting or receiving data at 40G.
Off	<p>Possible causes of this state are listed here:</p> <ul style="list-style-type: none"> - The transceiver slot is empty. - The transceiver has not established a link to a network device. - The LEDs are turned off. To turn on the LEDs, use the eco-friendly button in the management panel or the NO ECOFRIENDLY LED command in the command line interface. <hr/> <p>Note The AT-x950-52XSQ and AT-x950-52XTQm Switches do not have the eco-friendly button.</p>

LEDs for Breakout Cables

The LED states for breakout cables are described in Table 7.

Table 7. Link and Activity Status LEDs for 10G Breakout Cables

State	Description
Solid Amber	At least one of the four ports on the breakout cable has established a 10G link to a network device.

Table 7. Link and Activity Status LEDs for 10G Breakout Cables

State	Description
Flashing Amber	At least one of the four ports on the breakout cable is sending or receiving data.
Off	<p>Possible causes of this state are listed here:</p> <ul style="list-style-type: none"> - The transceiver slot is empty. - None of the ports on the breakout cable have established a link to a network device. - The LEDs are turned off. To turn on the LEDs, use the eco-friendly button in the management panel or the NO ECOFRIENDLY LED command in the command line interface. <hr/> <p>Note The AT-x950-52XSQ and AT-x950-52XTQm Switches do not have the eco-friendly button.</p>

**Port Numbering
for the
AT-x950-28XSQ
and
AT-x950-28XTQ
m Switches**

Table 8 lists the port numbering system for ports 25, 29, 33, and 37 on the AT-x950-28XSQ and AT-x950-28XTQm Switches when the switch is operating as a standalone unit, with the VCStack feature disabled:

Table 8. Port Numbering for Ports 25 to 37

Port	With Fiber Optic Transceiver or Direct Attach Cable	With Breakout Cable
25	port1.0.25	port1.0.25 port1.0.26 port1.0.27 port1.0.28
29	port1.0.29	port1.0.29 port1.0.30 port1.0.31 port1.0.32
33	port1.0.33	port1.0.33 port1.0.34 port1.0.35 port1.0.36

Table 8. Port Numbering for Ports 25 to 37 (Continued)

Port	With Fiber Optic Transceiver or Direct Attach Cable	With Breakout Cable
37	port1.0.37	port1.0.37 port1.0.38 port1.0.39 port1.0.40

Port Numbering for the AT-x950-52XSQ and AT-x950-52XTQm Switches

Table 9 lists the port numbering system for ports 49, 53, 57, and 61 on the AT-x950-52XSQ and AT-x950-52XTQm Switches when the switch is operating as a standalone unit, with the VCStack feature disabled:

Table 9. Port Numbering for Ports 49, 53, 57, and 61

Port	With Fiber Optic Transceiver or Direct Attach Cable	With Breakout Cable
49	port1.0.49	port1.0.49 port1.0.50 port1.0.51 port1.0.52
53	port1.0.53	port1.0.53 port1.0.54 port1.0.55 port1.0.56
57	port1.0.57	port1.0.57 port1.0.58 port1.0.59 port1.0.60
61	port1.0.61	port1.0.61 port1.0.62 port1.0.63 port1.0.64

For more information, refer to “Designating Ports in the Command Line Interface” on page 54.

Management Panel

The components on the management panel on the AT-x950-28XSQ and AT-x950-28XTQm Switches are identified in Figure 9.

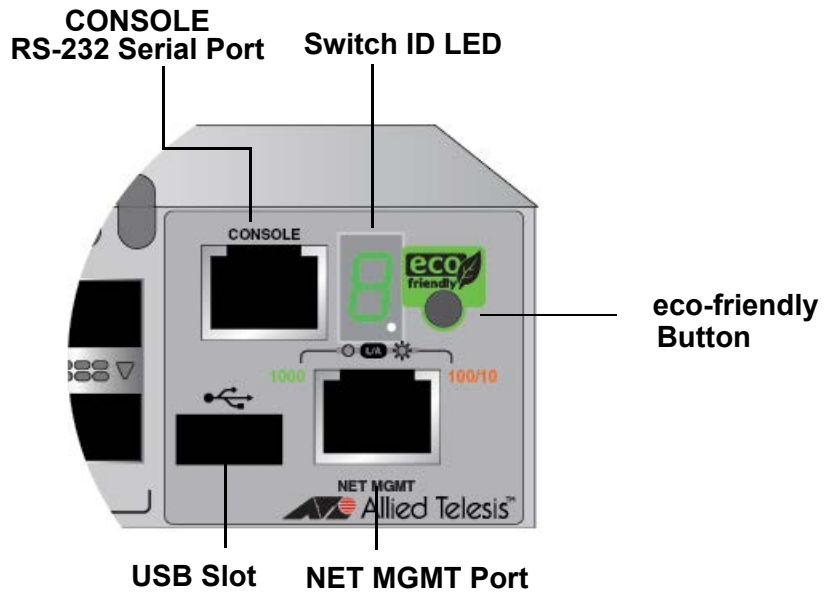


Figure 9. Management Panel on the AT-x950-28XSQ and AT-x950-28XTQm Switches

The components on the management panel on the AT-x950-52XSQ and AT-x950-52XTQm Switches are identified in Figure 10.

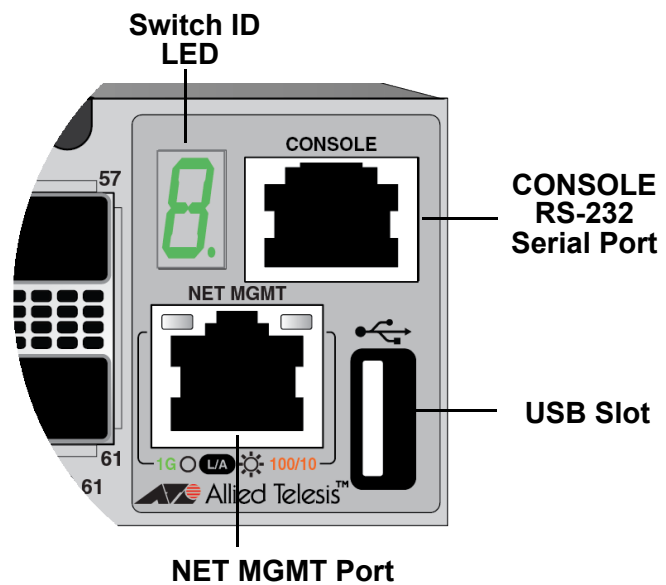


Figure 10. Management Panel on the AT-x950-52XSQ and AT-x950-52XTQm Switches

USB Port

The USB port in the management panel may be used to perform a variety of management functions. Examples of features that support the USB port are listed in Table 10.

Table 10. Examples of Switch Features that Support the USB Port

Feature	AlliedWare Plus Command
File and Configuration Management	
Configure the router using a configuration file on a USB storage device the next time it boots.	BOOT CONFIG-FILE
Direct the router to a USB storage device for the AlliedWare Plus operating system the next time it boots.	BOOT SYSTEM
Copy files to or from a USB storage device, or create duplicate files on the storage device.	COPY
Save debug files on a USB storage device to diagnose and troubleshoot network issues.	COPY DEBUG MOVE DEBUG
Save the running-config file on a USB storage device or copy a file from a USB storage device into the running-config. The file contains the router's current configuration, including commands not yet saved in the startup-config file.	COPY RUNNING-CONFIG
Save the startup-config file on a USB storage device, or copy a file from a USB storage device to the startup-config file. The file contains the router's currently saved configuration settings.	COPY STARTUP-CONFIG
Save autoboot.txt files on a USB storage device. The router uses the files to restore a release file and/or configuration file to its file system.	CREATE AUTOBOOT
Configure the switch to restore a release file and/or configuration file from a USB storage device.	AUTOBOOT ENABLE
List the files on a USB storage device.	DIR
Edit files on a USB storage device.	EDIT

Table 10. Examples of Switch Features that Support the USB Port

Feature	AlliedWare Plus Command
Close all open files and stop all management actions on a USB storage device. You should always perform this command before removing a storage device from the drive, to prevent corrupting data files.	UNMOUNT
Logging	
Delete the external log file from a USB storage device.	CLEAR LOG EXTERNAL
Copy the buffered log onto a USB storage device.	COPY BUFFERED-LOG
Copy the permanent log onto a USB storage device.	COPY PERMANENT-LOG
Save syslog messages in a file on a USB storage device.	LOG EXTERNAL
Display the contents of the external log on a USB storage device.	SHOW LOG EXTERNAL
Local RADIUS Server	
Create a set of local RADIUS server users from MAC addresses.	COPY FDB-RADIUS-USERS
Copy the local RADIUS server user data to a file.	COPY LOCAL-RADIUS-USER-D B
DHCP Snooping	
Store the dynamic entries in the DHCP snooping database in a file.	IP DHCP SNOOPING DATABASE
Virtual Chassis Stacking	
Delete files from the USB storage devices on all stack members.	DELETE STACK-WIDE FORCE
Display the directories on a USB storage devices on all stack members.	DIR STACK-WIDE

Table 10. Examples of Switch Features that Support the USB Port

Feature	AlliedWare Plus Command
Allied Telesis Management Framework (AMF)	
Remove guest node's backup files.	ATMF BACKUP GUESTS DELETE
Initiate manual synchronization of all guest backup file-sets across remote file servers and backup media.	ATMF BACKUP GUESTS SYNCHRONIZE
Enable or disable AMF backup redundancy.	ATMF BACKUP REDUNDANCY ENABLE
Reboot the nodes in an AMF working-set or upgrade the management software one AMF device at a time.	ATMF REBOOT-ROLLING
Delete a node's recovery files	CLEAR ATMF RECOVERY-FILE
Set the configuration file to use during the next boot cycle.	CONFIGURE BOOT CONFIG
Autonomous Wave Control	
Allow AlliedWare Plus to place the wireless network into emergency mode when you insert a pre-prepared USB storage device.	EMERGENCY-MODE USB ENABLE
Specify the key for placing the wireless network into emergency mode.	EMERGENCY-MODE USB KEY
Store wireless client and neighbor AP log files.	LOG ENABLE DESTINATION
Prepare a USB storage device to place the wireless network into emergency mode,	WIRELESS EMERGENCY-MODE USB MARK KEY
Retrieve and store technical support files from managed wireless access points.	WIRELESS GET-TECH AP
Retrieve and store technical support files from managed wireless access points that use the specified AP Profile ID.	WIRELESS GET-TECH AP-PROFILE

Table 10. Examples of Switch Features that Support the USB Port

Feature	AlliedWare Plus Command
Retrieves and stores technical support files from managed wireless access points that use the specified Smart Connect (SC) Profile ID.	WIRELESS GET-TECH SC-PROFILE
Trigger	
Configure a trigger that the router performs when a USB storage device is inserted or removed in the USB port.	TYPE USB

NET MGMT Ethernet Management Port

The switch uses the NET MGMT port as a separate routed eth0 interface. The interface is not part of the switching matrix, but the switch can route traffic in or out of the port from the network ports and XEM2 Line Card. Here are the guidelines:

- ❑ The port should only be used for initial configuration and maintenance access to the chassis.
- ❑ The NET MGMT port has a standard 8-pin RJ-45 connector and operates at 10M/100M/1000M in either half- or full-duplex mode.
- ❑ The default setting for the port is Auto-Negotiation, which sets the speed and duplex mode automatically. You may disable Auto-Negotiation and configure the port manually.
- ❑ The wiring configuration of the NET MGMT port is set automatically with automatic MDIX detection. You can disable automatic MDIX detection and set the wiring configuration manually.
- ❑ The port is referred to as eth0 in the management software.

The minimum cable requirements for the port are listed here:

- ❑ 10M/100M - Standard TIA/EIA 568-B-compliant Category 3 unshielded cabling.
- ❑ 1000M - Standard TIA/EIA 568-A-compliant Category 5 or TIA/EIA 568-B-compliant Enhanced Category 5 (Cat 5e) unshielded cabling.

For instructions on how to configure the NET MGMT port, refer to the *Software Reference for x950 Switch, AlliedWare Plus Operating System*.

The Network Management (NET MGMT) port has one Status LED, described in Table 11.

Table 11. NET MGMT Port LED

State	Description
Solid Green	The port has established a 1000M link with a network device.
Flashing Green	The port is transmitting or receiving data at 1000M.
Solid Amber	The port has established a 10M or 100M link.
Flashing Amber	The port is transmitting or receiving data at 10M or 100M.
Off	The port has not established a link to a network device.

Console (RS-232) Port

You use the Console Port to conduct local management sessions with the switch. Local management sessions require a terminal or PC with a terminal emulation program, and the management cable that comes with the switch. The switch does not need an Internet Protocol (IP) address for local management sessions because they are not conducted over a network. For instructions, refer to “Starting a Local Management Session” on page 175.

Note

The first management session of the switch can be either a local session or a remote session over your network through the NET MGMT port. For remote management, the switch uses either its default IP address 192.168.42.42 or an address assigned to it by a DHCP server. For instructions on remote management sessions, refer to the *Software Reference for x950 Switches, AlliedWare Plus Operating System*.

Switch ID LED

The Switch ID LED, shown in Figure 9 on page 35 or Figure 10 on page 35, displays a variety of information. Figure 11 on page 41 shows the states of the LED when the eco-friendly mode is disabled.

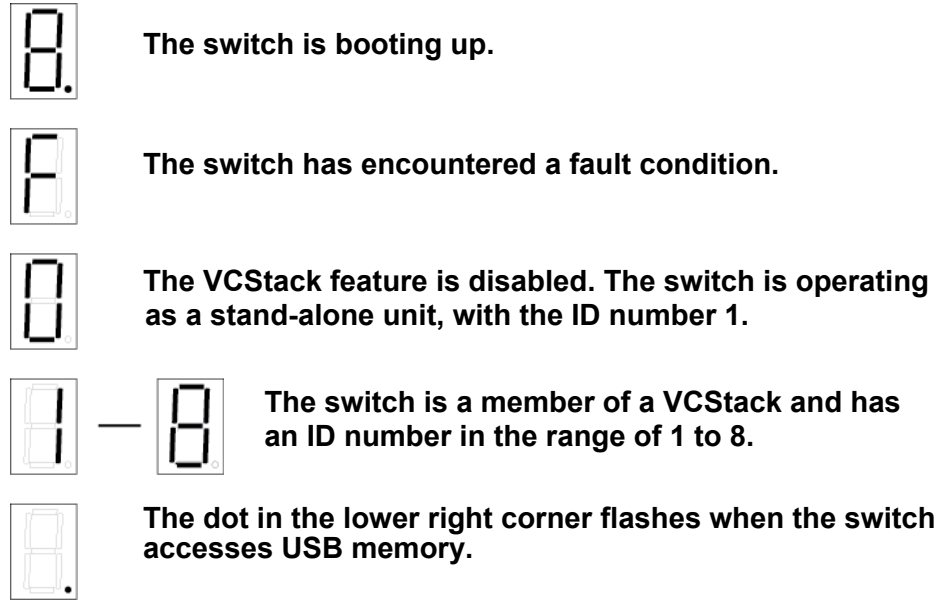


Figure 11. Switch ID LED with the eco-friendly Mode Disabled

The switch displays the letter “F” for fault on the ID LED if it detects one of the following problems:

- A cooling fan has failed.
- The switch is about to shut down because its internal temperature is outside the normal operating range.

Note

You can use the `SHOW SYSTEM ENVIRONMENT` command in the command line interface to identify the source of the problem.

Figure 12 illustrates the states of the LED when the eco-friendly mode is enabled and the switch is operating in the low power mode.

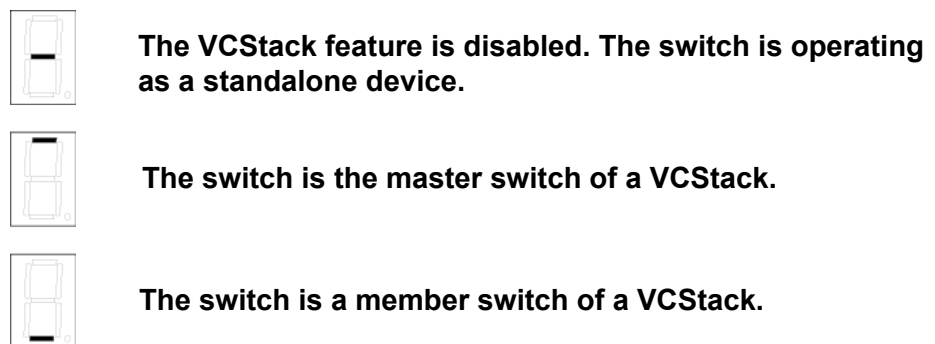


Figure 12. Switch ID LED with the eco-friendly Mode Enabled

eco-friendly Button

You use the eco-friendly button on the management panel to turn the LEDs on or off. You might turn off the LEDs when you are not using them to monitor the switch, to conserve electricity. When the LEDs are off, the overall power consumption of the chassis is reduced by approximately 2 watts.

The button controls all the port LEDs, except for the L/A LED for the NET MGMT port. Additionally, the button does not control the LEDs on the power supplies.

Note

The AT-x950-52XSQ and AT-x950-52XTQm Switches do not have the eco-friendly button. However, the eco-friendly mode can be turned on or off with the ECOFRIENDLY LED or NO ECOFRIENDLY LED command in the command line interface.

Direct Attach Cables

The optional direct attach cables listed in Table 12 offer an economical way to add 10G, 40G, and 100G connections over short distances for switch base ports and ports on XEM2 Line Cards.

Table 12. Optional Direct Attach Cables

Switch Ports	XEM2 Line Card	Speed	Direct Attach Cable
Ports 1 to 24 on AT-x950-28XSQ Ports 1 to 48 on AT-x950-52XSQ	AT-XEM2-8XSTm AT-XEM2-12XS AT-XEM2-12XS v2 ¹	10G	SP10TW1 - 1 meter SP10TW3 - 3 meters SP10TW7 - 7 meters
Ports 25, 29, 33, 37 on AT-x950-28XSQ and AT-x950-28XTQm Ports 49, 53, 57, 61 on AT-x950-52XSQ and AT-x950-52XTQm	AT-XEM2-4QS AT-XEM2-1CQ	40G 100G	AT-QSFP1CU - 1 meter AT-QSFP3CU - 3 meters AT-QSFP28-1CU - 1 meter AT-QSFP28-3CU - 3 meters

1. The AT-XEM2-12XS v2 Card supports the SP10TW1 and SP10TW3 cables. It does not support the SP10TW7 cable.

AT-PWR600 and AT-PWR600R AC and DC Power Supplies

The x950 Switches have four power supplies:

- ❑ AT-PWR600
- ❑ AT-PWR600R
- ❑ AT-PWR600-80
- ❑ AT-PWR600R-80

The power supplies differ in terms of AC or DC input power and airflow direction. Table 13 lists the power supplies, their input power, and airflow directions. Also included are the corresponding fan models for the power supplies.

Table 13. AT-PWR600 and AT-PWR600R AC and DC Power Supplies

Power Supply ¹	AC or DC Input	Airflow Direction in Switch	Fan Module
AT-PWR600	AC	Front-to-rear	AT-FAN05
AT-PWR600R	AC	Rear-to-front	AT-FAN05R
AT-PWR600-80	DC	Front-to-rear	AT-FAN05
AT-PWR600R-80	DC	Rear-to-front	AT-FAN05R

1. The power supply model names are on labels on the top panels of the power supplies. Refer to Figure 13 on page 45 and Figure 16 on page 48.

The airflow directions of the power supplies and fan modules in the switch must be the same. Otherwise, the switch might overheat from inadequate ventilation and cooling. Here are the guidelines:

- ❑ Switches with AT-PWR600 AC or AT-PWR600-80 DC Power Supplies must have AT-FAN05 fan modules.
- ❑ Switches with AT-PWR600R AC or AT-PWR600R-80 DC Power Supplies must have AT-FAN05R fan modules.

The AT-PWR600 AC Power Supply is shown in Figure 13.

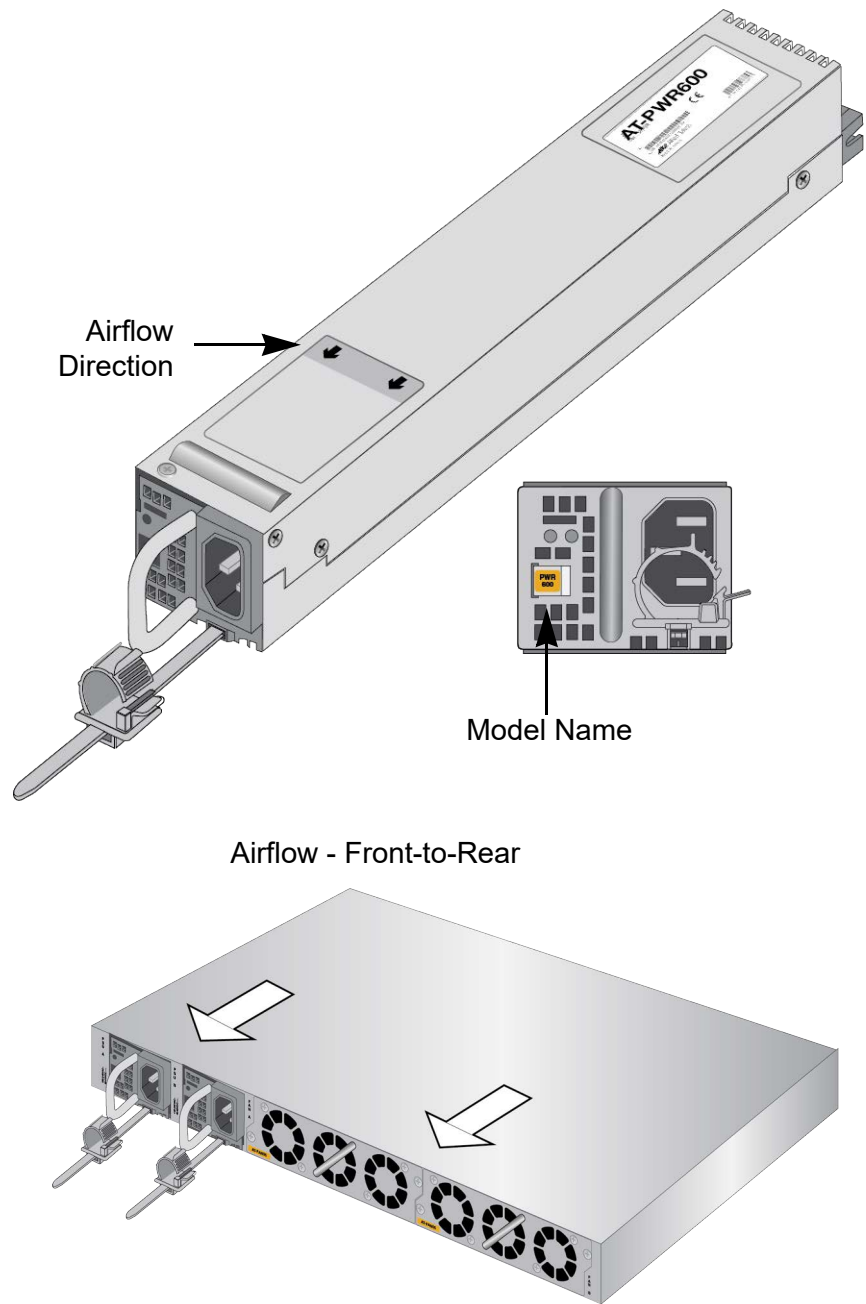


Figure 13. AT-PWR600 Power Supply and AT-FAN05 Fan Module

The AT-PWR600R AC Power Supply is shown in Figure 14.

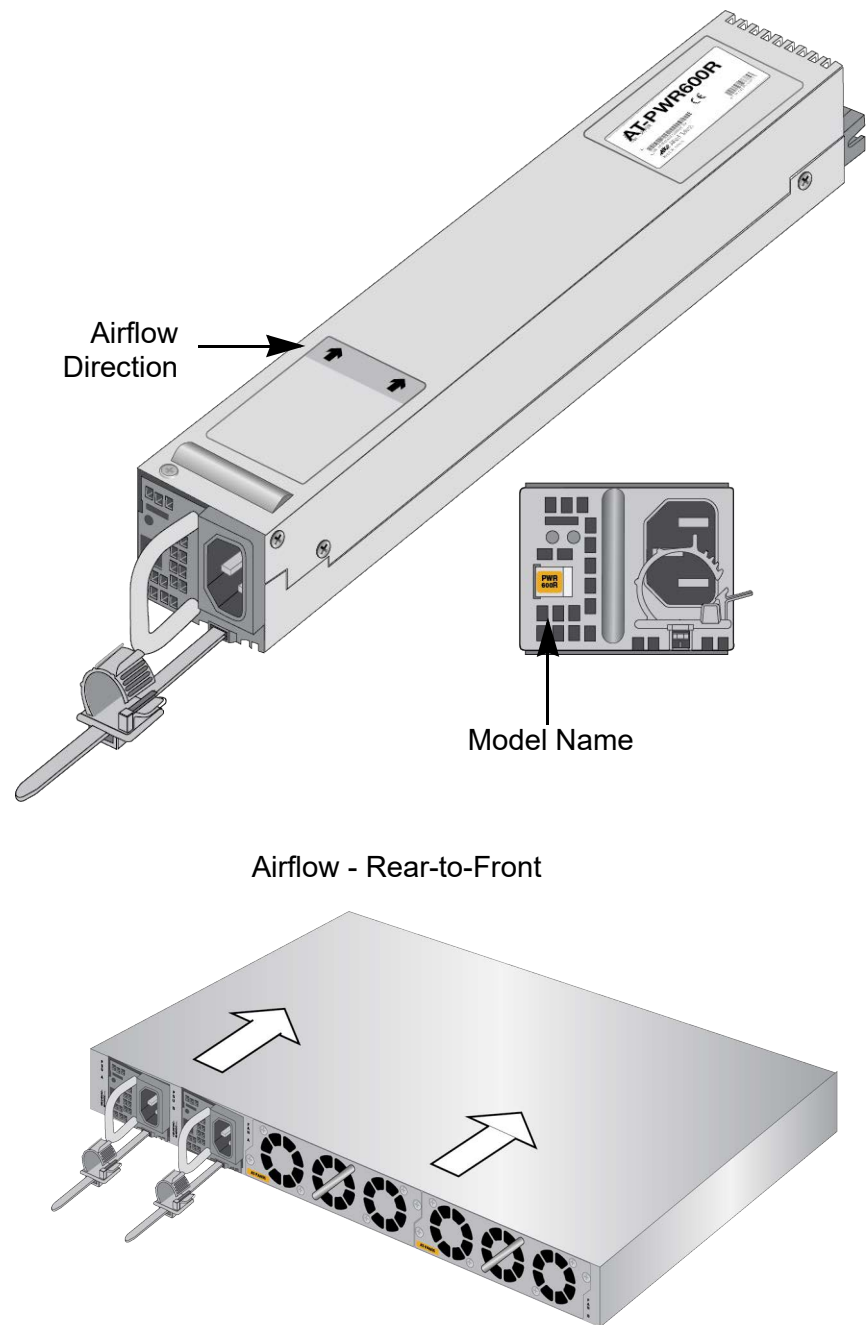
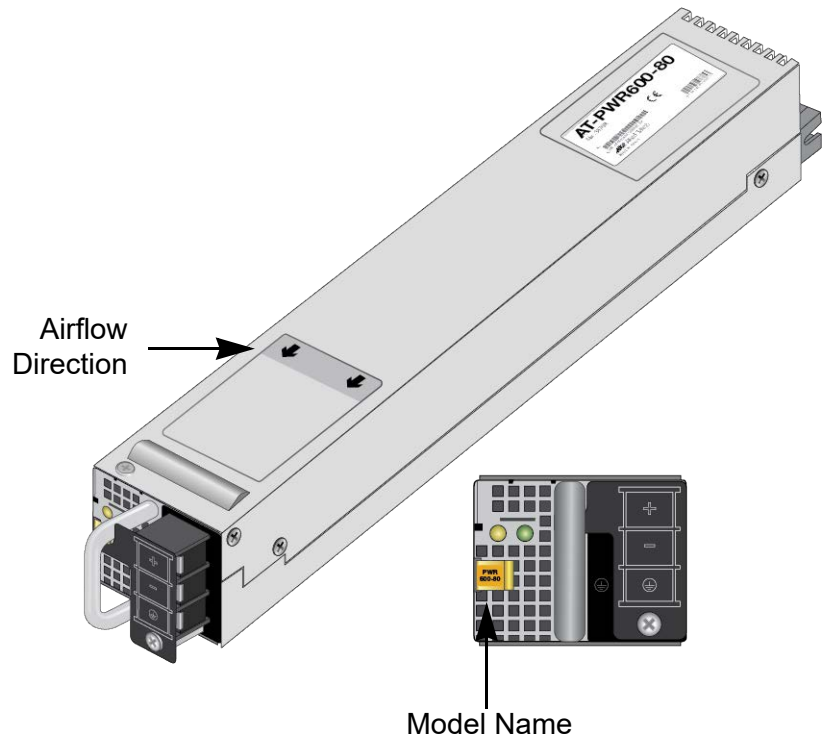


Figure 14. AT-PWR600R AC Power Supply and AT-FAN05R Fan Module

The AT-PWR600-80 DC Power Supply is shown in Figure 15.



Airflow - Front-to-Rear

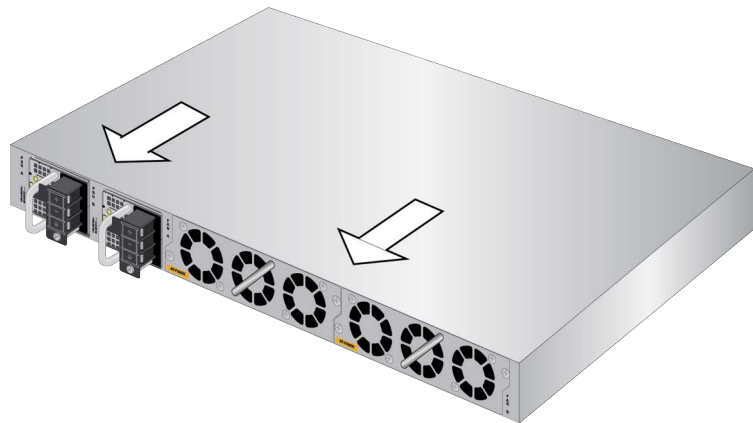
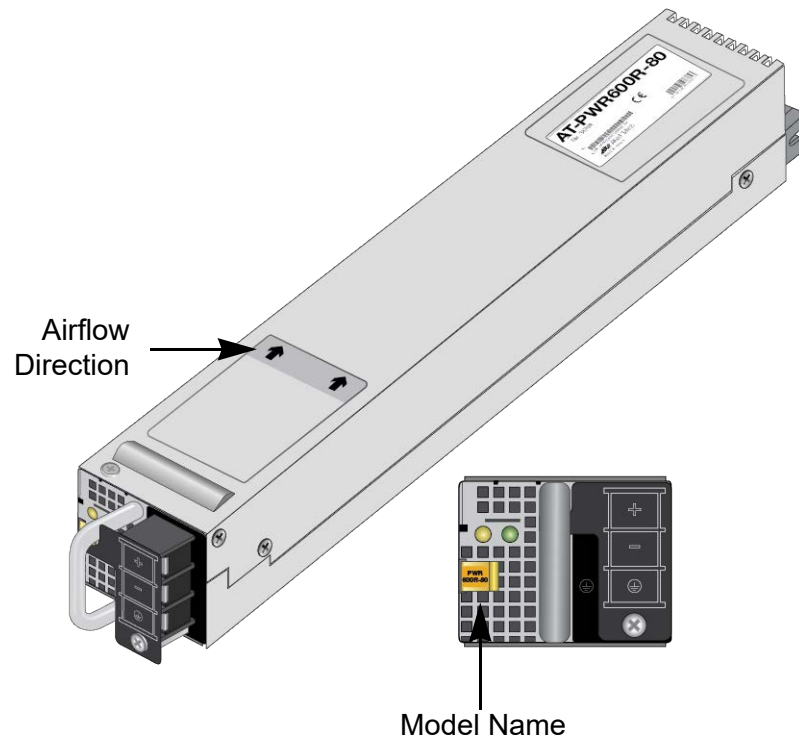


Figure 15. AT-PWR600-80 DC Power Supply and AT-FAN05 Fan Module

The AT-PWR600R-80 DC Power Supply is shown in Figure 16.



Airflow - Rear-to-Front

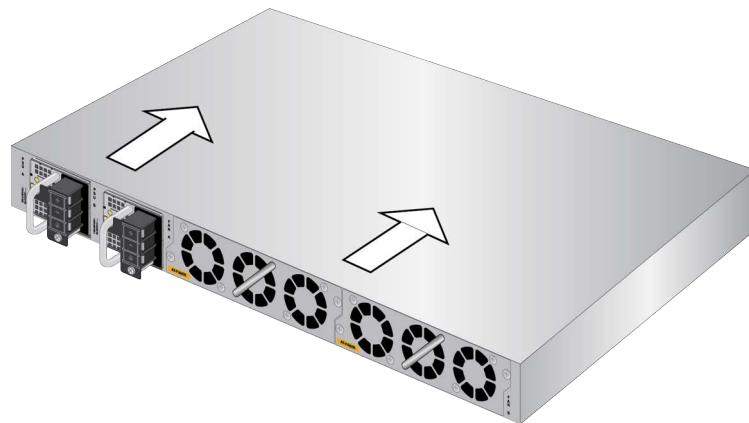


Figure 16. AT-PWR600R-80 DC Power Supply and AT-FAN05R Fan Module

Power Supply Guidelines

Here are guidelines for the AT-PWR600 AC and AT-PWR600-80 DC Power Supplies:

Note

The x950 Switches come with two pre-installed AT-FAN05 modules. You must replace them with two AT-FAN05R modules if you install AT-PWR600R or AT-PWR600R-80 Power Supplies.

- ❑ You can install either one or two power supplies in the switch. A single power supply can power a fully equipped switch. Installing two power supply units adds power redundancy.
- ❑ The power supplies are installed in the PSU A and PSU B slots in the rear panel of the chassis. If you are installing only one power supply, Allied Telesis recommends installing it in PSU A slot because that slot does not come with a blank slot cover.
- ❑ If you are installing two power supplies, they can be both AC, both DC, or AC and DC.
- ❑ The airflow directions of the power supplies and fan modules must be the same. Otherwise, the ventilation in the switch might be inadequate, causing the switch to overheat. Table 13 on page 44 and Table 16 on page 52 lists the power supplies and fan modules that have the same airflow directions.
- ❑ The switches do not come with power supply units. They are purchased separately.
- ❑ The power supplies are field-replaceable and hot-swappable. If the switch has two power supply units and one fails, you do not have to power off the operational power supply unit to replace the failed unit.

LEDs The two LEDs on the front panels of the AT-PWR600 and AT-PWR600R power supplies are described in Table 14.

Table 14. LEDs on the AT-PWR600 and AT-PWR600R AC Power Supplies

Green LED	Amber LED	Description
Solid green	Off	The power supply is operating normally.
Blinking green	Off	The power supply is in the standby mode.

Table 14. LEDs on the AT-PWR600 and AT-PWR600R AC Power Supplies (Continued)

Green LED	Amber LED	Description
Solid green	Blinking amber	<p>The power supply is experiencing a warning condition, but is still operating. Possible causes are listed here:</p> <ul style="list-style-type: none"> - The power supply is overheating. - The speed of its fan is too low. - Its output current is too high. - The input voltage from the AC power source is too low.
Off	Solid amber	<p>The power supply shut down because it experienced a fault condition. Possible causes are listed here:</p> <ul style="list-style-type: none"> - The power supply overheated. - The power supply's fan stopped or is too slow. - The output current from the power supply to the switch is too high. - The input voltage from the AC power source is too low.

The LEDs on the AT-PWR600-80 and AT-PWR600R-80 DC Power Supplies are defined in Table 15.

Table 15. LEDs on the AT-PWR600-80 and AT-PWR600R-80 DC Power Supplies

Green LED	Amber LED	Description
Solid green	Off	The power supply is operating normally.
Blinking green	Off	The power supply is in the standby mode.

Table 15. LEDs on the AT-PWR600-80 and AT-PWR600R-80 DC Power Supplies (Continued)

Green LED	Amber LED	Description
Solid green	Blinking amber	<p>The power supply is experiencing a warning condition, but is still operating. Possible causes are listed here:</p> <ul style="list-style-type: none"> - The power supply is overheating. - The speed of its fan is too low. - Its output current is too high. - The input voltage from the DC power source is too low.
Off	Solid amber	<p>The power supply shut down because it experienced a fault condition. Possible causes are listed here:</p> <ul style="list-style-type: none"> - The power supply overheated. - The power supply's fan stopped or is too slow. - The output current from the power supply to the switch is too high. - The input voltage from the DC power source is too low.

AT-FAN05 and AT-FAN05R Fan Modules

The x950 Switches have two fan modules:

- ❑ AT-FAN05
- ❑ AT-FAN05R

Refer to Figure 17.

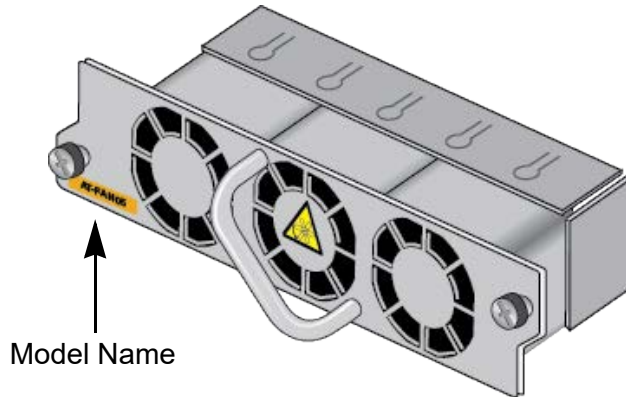


Figure 17. AT-FAN05 and AT-FAN05R Fan Modules

The two fan modules have different airflow directions:

- ❑ AT-FAN05 module: Front-to-rear of switch. The module's fans pull air from the switch.
- ❑ AT-FAN05R module: Rear-to-front of switch. The module's fans drive air into the switch.

The airflow directions of the fan modules and power supplies in the switch must be the same. Otherwise, the switch might overheat from inadequate ventilation and cooling. Table 16 lists the AT-FAN05 and AT-FAN05R fan modules with the matching power supply units.

Table 16. Fan Modules and Power Supplies

Fan Module ¹	Matching Power Supply	Airflow Direction
AT-FAN05	AT-PWR600 (AC) AT-PWR600-80 (DC)	Front-to-rear of switch
AT-FAN05R	AT-PWR600R (AC) AT-PWR600R-80 (DC)	Rear-to-front of switch

1. The model name is on the front panel of the fan module. See Figure 17.

For information on the power supplies, refer to “AT-PWR600 and AT-PWR600R AC and DC Power Supplies” on page 44.

Here are the guidelines to the fan modules:

Note

The x950 Switches come with two pre-installed AT-FAN05 modules in FAN A and FAN B slots on the rear panel. You must replace the fan modules with two AT-FAN05R modules if you install AT-PWR600R or AT-PWR600R-80 Power Supplies.

- ❑ The switch must have two fan modules for adequate cooling and ventilation.
- ❑ The switch comes with two pre-installed AT-FAN05 fan modules.
- ❑ The two fan modules must be the same. Installing different fan modules in the switch may result in inadequate ventilation and cooling, which may cause the switch to overheat.
- ❑ The airflow directions of the fan modules and power supplies in the switch must be the same. Otherwise, the switch might overheat from inadequate ventilation and cooling. Refer to Table 13 on page 44 or Table 16 on page 52 for matching power supplies and fan modules.
- ❑ The fan modules are field-replaceable and hot-swappable. You do not have to power off the switch to replace them.
- ❑ The switch automatically adjusts the fan speeds according to its internal temperature.

Designating Ports in the Command Line Interface

The individual ports on the switch are identified with the PORT parameter in the command line interface of the AlliedWare Plus management software. The format of the parameter for a standalone switch is shown in Figure 18.

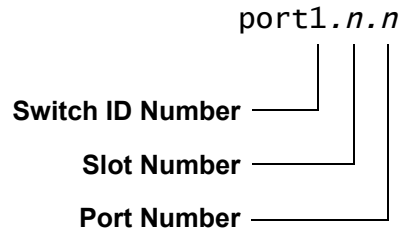


Figure 18. PORT Parameter in the Command Line Interface for a Standalone Switch

The three parts of the PORT parameter are defined in Table 17.

Table 17. PORT Parameter Format for a Standalone Switch

Number	Description
Switch ID Number	Identifies the switch’s ID number. Please review the following: <ul style="list-style-type: none"> - The default value is 1. - Allied Telesis recommends using the default value for standalone switches. - A standalone switch that was previously a stack member retains its ID number from the stack. - The switch displays “0” on the Switch ID LED on the front panel when VCStack is disabled and it is operating as a standalone switch.

Table 17. PORT Parameter Format for a Standalone Switch (Continued)

Number	Description
Slot Number	Identifies whether ports are base ports or ports on an XEM2 Line Card. The slot values are: <ul style="list-style-type: none"> - 0 - Identifies base ports. - 1- Indicates ports on the XEM2 Line Card in AT-x950-28XSQ and AT-x950-28XTQm Switches. Refer to Figure 19 on page 55. <div style="border: 1px solid black; padding: 5px; margin-top: 10px;"> <p>Note The AT-x950-52XSQ and AT-x950-52XTQm Switches do not support XEM2 Line Cards.</p> </div>
Port Number	Identifies a port number.

Base Ports and XEM2 Line Card Ports

The AT-x950-28XSQ and AT-x950-28XTQm Switches have two types of ports. They have the ports that come with the switch, referred to as base ports, and ports on the optional XEM2 Line Cards. You use different slot numbers to identify the two groups of ports in the command line interface. The slot number for the base ports is “0”. The slot number for ports on the XEM2 Line Card is “1”. Refer to Figure 19.

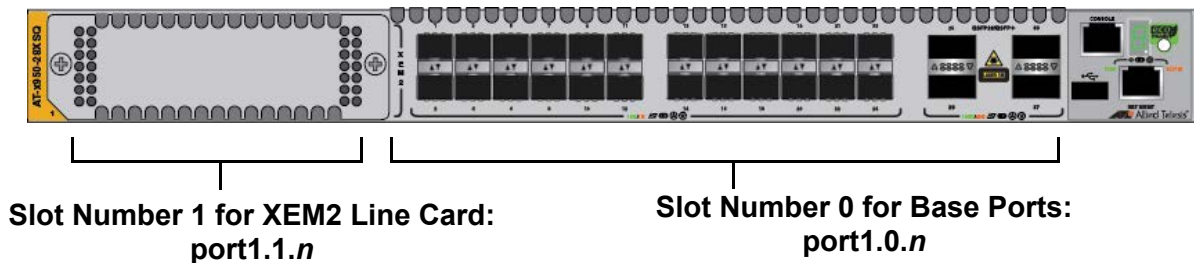


Figure 19. Slot Numbers for Port Numbering on AT-x950-28XSQ and AT-x950-28XTQm Switches

Note

The AT-x950-52XSQ and AT-x950-52XTQm Switches have base ports only. The slot number for their ports in the PORT parameter is always “0”.

Examples for the PORT Parameter on Base Ports

Here are examples of the PORT parameter in the INTERFACE command for base ports on standalone switches. You must include the PORT parameter with port numbers when specifying individual ports. The first example enters the port interface modes for base ports 11 and 14:

```
awplus> enable
awplus# configure terminal
awplus(config)# interface port1.0.11,port1.0.14
```

The example enters the port interface modes for base ports 1 and 9:

```
awplus> enable
awplus# configure terminal
awplus(config)# interface port1.0.1,port1.0.9
```

When specifying a range of ports, include the PORT parameter in the first port number, and omit it from the last port number. This example enters the port interface modes for base ports 6 to 10:

```
awplus(config)# interface port1.0.6-1.0.10
```

Examples of the PORT Parameter for the XEM2 Line Card

These examples apply to the XEM2 expansion slots in the AT-x950-28XSQ and AT-x950-28XTQm Switches. The first example enters the port interface modes for ports 4 and 5 on the XEM2 Line Card in the expansion slot:

```
awplus(config)# interface port1.1.4,port1.1.5
```

You can enter the port interface modes of both base ports and XEM2 Line Card ports with the same command. This example enters the port interface mode for base port 6 and line card port 5:

```
awplus(config)# interface port1.0.6,port1.1.5
```

Examples of the PORT Parameter for Breakout Cables

The four 40G/100G QSFP+/QSFP28 ports on the switches and the four 40G QSFP+ ports on the AT-XEM2-4QS Line Card support breakout cables. The cables convert a port into four individual 10G connections that function as independent ports. An example of a breakout cable is shown in Figure 20.



Figure 20. Copper Breakout Cable

The port numbers with and without breakout cables for the 40G/100G QSFP+/QSFP28 ports on the AT-x950-28XTQm and AT-x950-28XSQ Switches are listed in Table 18 on page 57.

Table 18. Port Numbers with and without Breakout Cables on the AT-x950-28XTQm and AT-x950-28XSQ Switches

Port Numbers without Breakout Cables	Port Numbers with Breakout Cables
25	25-28
29	29-32
33	33-36
37	37-40

The port numbers with and without breakout cables for the 40G/100G QSFP+/QSFP28 ports on the AT-x950-52XTQm and AT-x950-52XSQ Switches are listed in Table 19.

Table 19. Port Numbers with and without Breakout Cables on the AT-x950-52XTQm and AT-x950-52XSQ Switches

Port Numbers without Breakout Cables	Port Numbers with Breakout Cables
49	49-52
53	53-56
57	57-60
61	61-64

The port numbers with and without breakout cables for the ports on the AT-XEM2-4QS Line Card are listed in Table 20.

Table 20. Port Numbers with and without Breakout Cables on the AT-XEM2-4QS Line Card

Port Numbers without Breakout Cables	Port Numbers with Breakout Cables
1	1-4
5	5-8
9	9-12
13	13-16

To identify a 40G/100G port without a breakout cable in the command line interface, use the first port of the range. For example, to enter the port interface mode in the command line interface for port 33 in the AT-x950-28XSQ or AT-x950-28XTQm Switch, you enter these commands:

```
awplus> enable
awplus# configure terminal
awplus(config)# interface port1.0.33
```

This example enters the port interface mode for 40G/100G port 57 in the AT-x950-52XTQm or AT-x950-52XSQ Switch:

```
awplus> enable
awplus# configure terminal
awplus(config)# interface port1.0.57
```

The four connectors on a breakout cable are numbered 1 to 4, with each connector functioning as a separate port. You can configure each port separately in the command line interface. For example, to enter the port interface mode for connector 3 on the breakout cable in port 57 of the AT-x950-52XSQ or AT-x950-52XTQm Switch, you enter these commands:

```
awplus> enable
awplus# configure terminal
awplus(config)# interface port1.0.59
```

To enter the port interface mode for connector 4 on the breakout cable in port 13 of the AT-XEM2-4QS Line Card, you enter these commands:

```
awplus> enable
awplus# configure terminal
awplus(config)# interface port1.1.16
```

For further instructions, refer to the *Software Reference for x950 Switches, AlliedWare Plus Operating System*.

Software and Hardware Releases

The software and hardware releases for the AlliedWare Plus operating software and x950 Switches are listed in Table 21.

Table 21. Software and Hardware Releases

Software Version	Hardware / VCStack
v5.4.8-2	AT-x950-28XSQ Switch AT-XEM2-12XT Line Card AT-XEM2-12XS Line Card AT-XEM2-4QS Line Card AT-XEM2-1CQ Line Card VCStack - Stacks up to two switches.
v5.4.9	VCStack - Stacks up to four switches.*
v5.4.9-1	AT-x950-28XTQm Switch AT-XEM2-12XTm Line Card AT-XEM2-12XT Line Card - Added 100M port speed
v5.4.9-2	AT-XEM2-8XSTm Line Card AT-XEM2-12XS v2 Line Card
v5.4.9-2.3	VCStack - Stacks up to eight switches.*
v5.5.0-1	AT-x950-52XSQ Switch
v5.5.1-0.1	AT-x950-52XTQm Switch

* For more information, see the *x950 Series Switches Installation Guide for Virtual Chassis Stacking*.

Chapter 2

XEM2 Ethernet Line Cards

The chapter contains the following sections:

- “Overview” on page 62
- “AT-XEM2-8XSTm Line Card” on page 65
- “AT-XEM2-12XT Line Card” on page 69
- “AT-XEM2-12XTm Line Card” on page 71
- “AT-XEM2-12XS and AT-XEM2-12XS v2 Line Cards” on page 73
- “AT-XEM2-4QS Line Card” on page 76
- “AT-XEM2-1CQ Line Card” on page 78

Overview

The AT-x950-28XSQ and AT-x950-28XTQm Switches have one expansion slot on the front panel for an optional XEM2 Line Card. See Figure 21.

Note

The AT-x950-52XSQ-52XSQ and AT-x950-52XTQm Switches do not support XEM2 Line Cards.

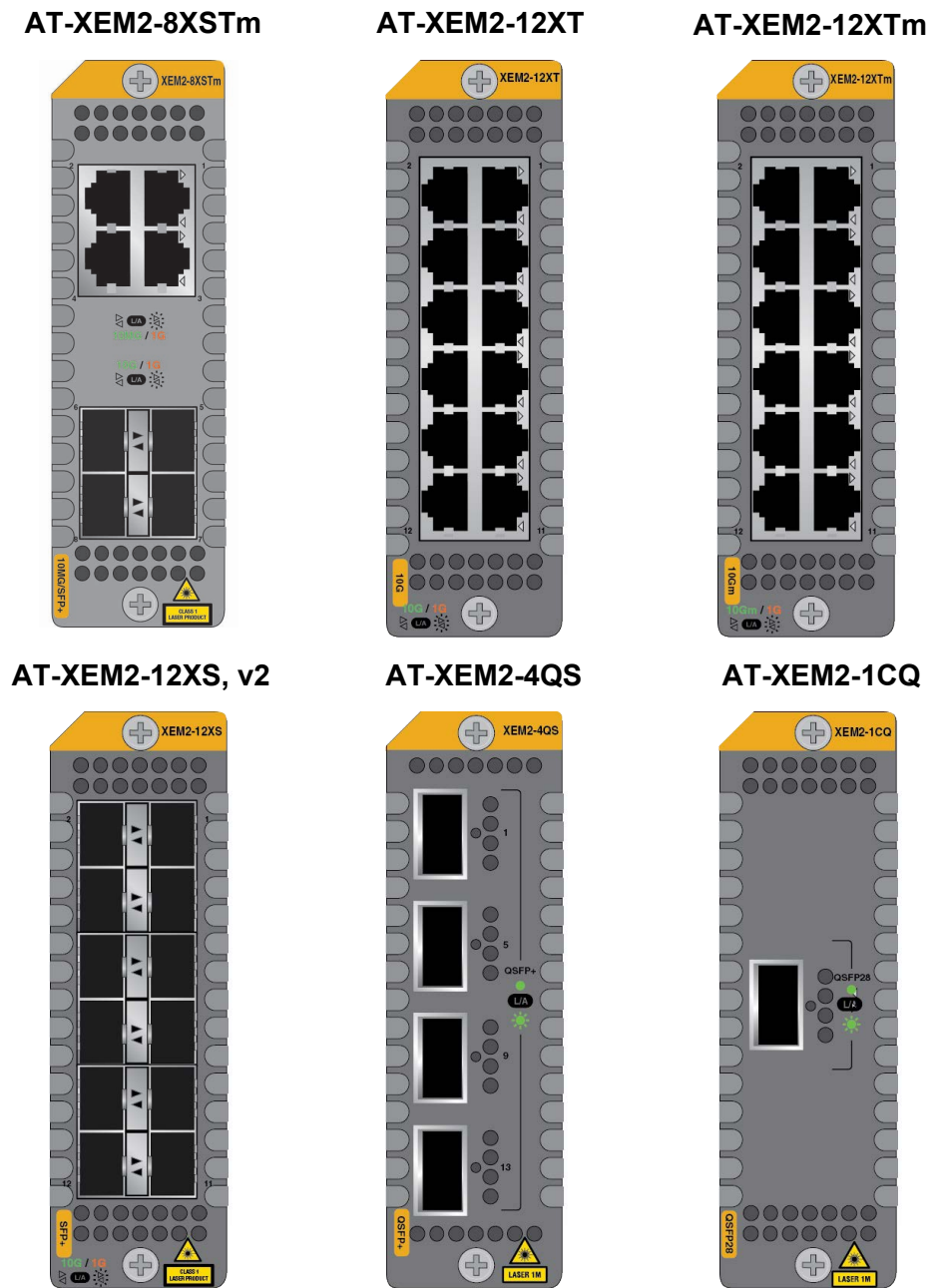


Figure 21. XEM2 Ethernet Line Cards

The XEM2 Ethernet Line Cards are described in Table 22.

Table 22. XEM2 Ethernet Line Cards

Line Card	Description
AT-XEM2-8XSTm	<p>Four copper ports (1-4) with RJ-45 connectors that support the following speeds:</p> <ul style="list-style-type: none"> - 100M - 1G/2.5G/5G/10G <p>Four ports (5-8) that support the following types of transceivers:</p> <ul style="list-style-type: none"> - 1G SFP - 10G SFP+ - 10G one meter AT-SP10TW1 and three meter AT-SP10TW3 direct connect twinax cables. (The card does not support the seven meter AT-SP10TW7 cable.) <p>Refer to “AT-XEM2-8XSTm Line Card” on page 65.</p>
AT-XEM2-12XT	<p>12 copper ports with RJ-45 connectors that support the following speeds:</p> <ul style="list-style-type: none"> - 100M (requires AlliedWare Plus v5.4.9-0 or later.) - 1G/10G <p>Refer to “AT-XEM2-12XT Line Card” on page 69.</p>
AT-XEM2-12XTm	<p>12 copper ports with RJ-45 connectors that support the following speeds:</p> <ul style="list-style-type: none"> - 100M - 1G/2.5G/5G/10G <p>Refer to “AT-XEM2-12XTm Line Card” on page 71. (This card requires AlliedWare Plus v5.4.9-0 or later.)</p>

Table 22. XEM2 Ethernet Line Cards (Continued)

Line Card	Description
<p>AT-XEM2-12XS and AT-XEM2-12XS v2</p>	<p>12 ports that support the following types of transceivers:</p> <ul style="list-style-type: none"> - 1G SFP - 10G SFP+ - 10G one meter AT-SP10TW1, three meter AT-SP10TW3, and seven meter AT-SP10TW7 direct connect twinax cables (The AT-XEM2-12XS v2 Card does not support the AT-SP10TW7 cable.) <p>Refer to “AT-XEM2-12XS and AT-XEM2-12XS v2 Line Cards” on page 73.</p>
<p>AT-XEM2-4QS</p>	<p>Four ports that support the following types of transceivers:</p> <ul style="list-style-type: none"> - 40G QSFP+ transceivers - 40G QSFP+ direct connect cables - AT-QSFP-4SFP10G-3CU and AT-QSFP-4SFP10G-5CU 40G to 4x10G breakout cables <p>Refer to “AT-XEM2-4QS Line Card” on page 76.</p>
<p>AT-XEM2-1CQ</p>	<p>One port for the 100G QSFP28 transceiver or AT-QSFP28-1CU or AT-QSFP28-3CU direct attach cable. Refer to “AT-XEM2-1CQ Line Card” on page 78.</p>

- ❑ The AT-XEM2-8XSTm Card requires AlliedWare Plus v5.4.9-2 or later.
- ❑ The 100M port speed on the AT-XEM2-12XT Card requires AlliedWare Plus v5.4.9-0 or later.
- ❑ The AT-XEM2-12XTm Card requires AlliedWare Plus v5.4.9-0 or later.

For more information, refer to “Software and Hardware Releases” on page 59.

AT-XEM2-8XSTm Line Card

The AT-XEM2-8XSTm Line Card is shown in Figure 22.

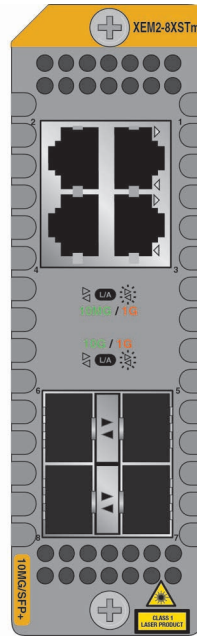


Figure 22. AT-XEM2-8XSTm Line Card

Copper Ports The AT-XEM2-8XSTm Card has four copper ports and four SFP ports. The specifications for the copper ports are listed in Table 23.

Table 23. Copper Ports on the AT-XEM2-8XSTm Line Card

Specification	Description
Port Speed	<p>The ports support the following speeds:</p> <ul style="list-style-type: none"> - 100M - 1G/2.5G/5G/10G <p>The ports do not support 10M.</p> <p>You can set port speed with Auto-Negotiation or manually. The default is Auto-Negotiation.</p>
Duplex Mode	Full-duplex only.

Table 23. Copper Ports on the AT-XEM2-8XSTm Line Card (Continued)

Specification	Description
Cabling	Minimum cable requirements are: <ul style="list-style-type: none"> - 100M - Standard TIA/EIA 568-B-compliant Category 3 unshielded cabling. - 1G/2.5G/5G - Standard TIA/EIA 568-A-compliant Category 5 or TIA/EIA 568-B-compliant Enhanced Category 5 (Cat 5e) unshielded cabling. - 10G -Standard TIA/EIA 568-C-compliant Category 6a unshielded cabling.
Maximum Distance	100 meters (328 feet)
Connector	8-pin RJ-45

Copper Port LEDs

Each port has a single LED that displays link and activity information. The states of LEDs are described in Table 24.

Table 24. Link and Activity LEDs for the Copper Ports on the AT-XEM2-8XSTm Line Card

State	Description
Solid Green	The port has established a 2.5G, 5G, or 10G link to a network device.
Flashing Green	The port is transmitting or receiving data at 2.5G, 5G, or 10G.
Solid Amber	The port has established a 100M or 1G link to a network device.
Flashing Amber	The port is transmitting or receiving data at 100M or 1G.

Table 24. Link and Activity LEDs for the Copper Ports on the AT-XEM2-8XSTm Line Card (Continued)

State	Description
Off	<p>Possible causes of this state are listed here:</p> <ul style="list-style-type: none"> - The port has not established a link with another network device. - The LEDs are turned off. To turn on the LEDs, use the eco-friendly button in the management panel or the NO ECOFRIENDLY LED command in the command line interface.

Transceiver Ports

The AT-XEM2-8XSTm Card also has four transceiver ports that support the following types of 1G SFP or 10G SFP+ transceivers:

- 1G SX or LX SFP fiber optic transceivers
- 10G SR or LR SFP+ fiber optic transceivers
- 10G one meter AT-SP10TW1 and three meter AT-SP10TW3 direct connect twinax cables, with SFP+ transceiver-style connectors

Note

The AT-XEM2-8XSTm Card does not support the seven meter AT-SP10TW7 direct connect cable.

Guidelines about the SFP+ transceiver ports are listed here:

- The ports do not support 100M transceivers.
- The ports support full-duplex mode only.
- You can set the port speeds with Auto-Negotiation or manually. The default is Auto-Negotiation.

SFP and SFP+ transceivers are purchased separately. For a list of supported transceivers, refer to the SBx908 GEN2 Series data sheet on the Allied Telesis web site.

Transceiver Port LEDs

The ports have link and activity LEDs. The states of the LEDs are described in Table 25.

Table 25. Link and Activity LEDs for the SFP Ports on the AT-XEM2-8XSTm Line Card

State	Description
Solid Green	The transceiver in the slot has established a 10GBase link to a network device.
Flashing Green	The transceiver is transmitting or receiving data at 10GBase.
Solid Amber	The transceiver has established a 1GBase link to a network device.
Flashing Amber	The transceiver is transmitting or receiving data at 1GBase.
Off	<p>Possible causes of this state are listed here:</p> <ul style="list-style-type: none"> - The transceiver has not established a link with another network device. - The LEDs are turned off. To turn on the LEDs, use the eco-friendly button in the management panel or the NO ECOFRIENDLY LED command in the command line interface.

AT-XEM2-12XT Line Card

The AT-XEM2-12XT Line Card is shown in Figure 23.

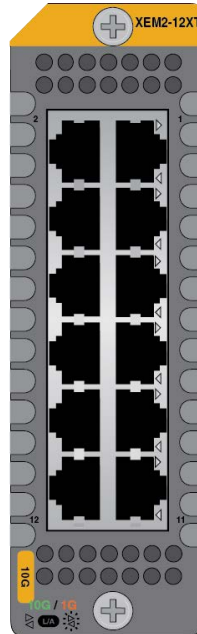


Figure 23. AT-XEM2-12XT Line Card

Copper Ports

The card has 12 copper ports with standard 8-pin RJ-45 ports. The specifications of the ports are listed in Table 26.

Table 26. Copper Ports on the AT-XEM2-12XT Line Card

Specification	Description
Port Speed	<p>The ports support the following speeds:</p> <ul style="list-style-type: none"> - 100M (Requires AlliedWare Plus v5.4.9-0 or later) - 1G/10G <p>The ports do not support 10M.</p>
Duplex Mode	Full-duplex only

Table 26. Copper Ports on the AT-XEM2-12XT Line Card (Continued)

Specification	Description
Cabling	The minimum cable requirements are: <ul style="list-style-type: none"> - 100M - Standard TIA/EIA 568-B-compliant Category 3 unshielded cabling. - 1G - Standard TIA/EIA 568-A-compliant Category 5 or TIA/EIA 568-B-compliant Enhanced Category 5 (Cat 5e) unshielded cabling. - 10G -Standard TIA/EIA 568-C-compliant Category 6a unshielded cabling.
Maximum Distance	100 meters (328 feet)
Connector	8-pin RJ-45

LEDs Each port has a single LED that displays link and activity information. Refer to Table 27.

Table 27. Port Link and Activity LEDs on the AT-XEM2-12XT Line Card

State	Description
Solid Green	The port has established a 10GBase link to a network device.
Flashing Green	The port is transmitting or receiving data at 10GBase.
Solid Amber	The port has established a 100M or 1GBase link to a network device.
Flashing Amber	The port is transmitting or receiving data at 100M or 1GBase.
Off	Possible causes of this state are listed here: <ul style="list-style-type: none"> - The port has not established a link with another network device. - The LEDs are turned off. To turn on the LEDs, use the eco-friendly button in the management panel or the NO ECOFRIENDLY LED command in the command line interface.

AT-XEM2-12XTm Line Card

The AT-XEM2-12XTm Card is shown in Figure 24.

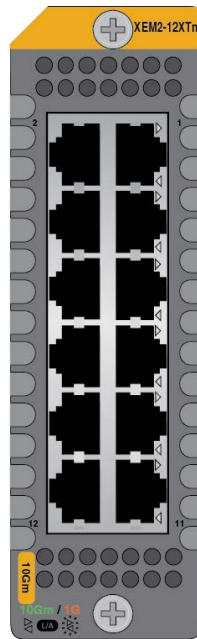


Figure 24. AT-XEM2-12XTm Line Card

Copper Ports

The AT-XEM2-12XTm Card has 12 copper ports with standard 8-pin RJ-45 ports. The specifications of the ports are listed in Table 28.

Table 28. Copper Ports on the AT-XEM2-12XTm Line Card

Specification	Description
Port Speed	<p>The ports support the following speeds:</p> <ul style="list-style-type: none"> - 100M - 1G/2.5G/5G/10G <p>The ports do not support 10M.</p> <p>You can set port speed with Auto-Negotiation or manually. The default is Auto-Negotiation.</p>
Duplex Mode	Full-duplex only.

Table 28. Copper Ports on the AT-XEM2-12XTm Line Card (Continued)

Specification	Description
Cabling	The minimum cable requirements are: <ul style="list-style-type: none"> - 100M - Standard TIA/EIA 568-B-compliant Category 3 unshielded cabling. - 1G/2.5G/5G - Standard TIA/EIA 568-A-compliant Category 5 or TIA/EIA 568-B-compliant Enhanced Category 5 (Cat 5e) unshielded cabling. - 10G -Standard TIA/EIA 568-C-compliant Category 6a unshielded cabling.
Maximum Distance	100 meters (328 feet)
Connector	8-pin RJ-45

LEDs Each port has a single LED that displays link and activity information. The states of LEDs are described in Table 29.

Table 29. Link and Activity LEDs on the AT-XEM2-12XTm Line Card

State	Description
Solid Green	The port has established a 2.5G, 5G, or 10G link to a network device.
Flashing Green	The port is transmitting or receiving data at 2.5G, 5G, or 10G.
Solid Amber	The port has established a 100M or 1GBase link to a network device.
Flashing Amber	The port is transmitting or receiving data at 100M or 1GBase.
Off	Possible causes of this state are listed here: <ul style="list-style-type: none"> - The port has not established a link with another network device. - The LEDs are turned off. To turn on the LEDs, use the eco-friendly button in the management panel or the NO ECOFRIENDLY LED command in the command line interface.

AT-XEM2-12XS and AT-XEM2-12XS v2 Line Cards

The AT-XEM2-12XS Line Card is shown in Figure 25.

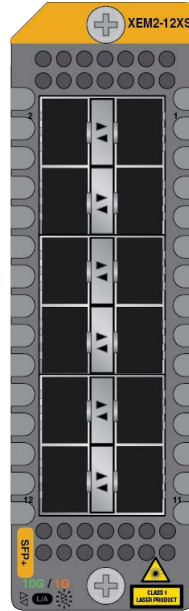


Figure 25. AT-XEM2-12XS Line Card

Transceiver Ports

The card has twelve ports that support the following types of 1G SFP, 10G SFP+, and 1G/2.5G/5G/10G transceivers with RJ-45 connectors:

- 1G SX or LX SFP transceivers
- 1G SPTX transceivers with RJ-45 ports for copper cable
- 10G SR or LR SFP+ fiber optic transceivers
- 10G one meter AT-SP10TW1, three meter AT-SP10TW3, and seven meter AT-SP10TW7 direct connect twinax cables with SFP+ transceiver-style connectors
- 1G/10G SP10T transceivers with copper RJ-45 ports cable
- 1G/2.5G/5G/10G SP10TM transceivers with copper RJ-45 ports

Note

The AT-XEM2-12XS v2 Card does not support the seven meter AT-SP10TW7 direct connect cable.

Guidelines about the ports are listed here:

- They do not support 100M transceivers.
- They support full-duplex mode only.

- ❑ You can set the port speeds with Auto-Negotiation or manually. The default is Auto-Negotiation.

SFP or SFP+ transceivers must be purchased separately. For a list of supported transceivers, refer to the x950 Switches data sheet on the Allied Telesis web site.

Card Versions

There are two versions of the AT-XEM2-12XS Line Card. Their names are “AT-XEM2-12XS” and “AT-XEM2-12XS v2.” Refer to Figure 26.



Figure 26. AT-XEM2-12XS and AT-XEM2-12XS v2 Line Cards

Note

The AT-XEM2-12XS v2 Line Card requires AlliedWare Plus v5.4.9-2 or later.

Note

Unless stated otherwise, the “AT-XEM2-12XS” model name in this manual refers to both cards.

LEDs

The ports have link and activity LEDs. The LED states are described in Table 30.

Table 30. Port Link and Activity LEDs on the AT-XEM2-12XS Line Card

State	Description
Solid Green	The transceiver has established a 10G link to a network device.
Flashing Green	The transceiver is transmitting or receiving data at 10G.
Solid Amber	The transceiver has established a 1G link to a network device.
Flashing Amber	The transceiver is transmitting or receiving data at 1G.

Table 30. Port Link and Activity LEDs on the AT-XEM2-12XS Line Card

State	Description
Off	<p>Possible causes of this state are listed here:</p> <ul style="list-style-type: none">- The transceiver has not established a link with another network device.- The LEDs are turned off. To turn on the LEDs, use the eco-friendly button in the management panel or the NO ECOFRIENDLY LED command in the command line interface.

AT-XEM2-4QS Line Card

The AT-XEM2-4QS Line Card is shown in Figure 27.

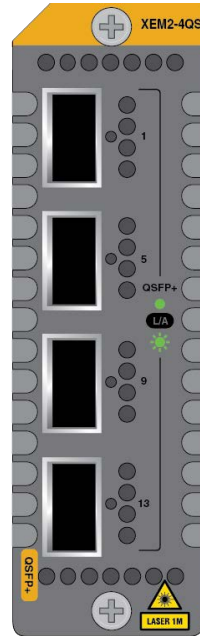


Figure 27. AT-XEM2-4QS Line Card

Transceiver Ports

Here are examples of the types of 40G QSFP+ transceivers supported by the line card:

- ❑ AT-QSFPSR4 transceiver - Maximum operating distance of 150 meters (492 feet) with 12-strand OM4 fiber optic cable.
- ❑ AT-QSFPLR4 transceiver - Operating range of 2 meters (6.6 feet) to 10 kilometers (6.2 miles) with single-mode fiber optic cable.
- ❑ AT-QSFP1CU and AT-QSFP3CU direct attach cables - Lengths of one and three meters, respectively.
- ❑ AT-QSFP-4SFP10G-3CU and AT-QSFP-4SFP10G-5CU 40G to 4x10G breakout cables in lengths of three and five meters, respectively. Refer to “Breakout Cables” on page 30 for more information.

LEDs The LED states for transceivers or direct attach cables in ports on the AT-XEM2-4QS Line Card are described in Table 31.

Table 31. Port Link and Activity Status LEDs on the AT-XEM2-4QS Line Card

State	Description
Solid Green	The transceiver has established a 40G link to a network device.
Flashing Green	The transceiver is transmitting or receiving data.
Off	<p>Possible causes of this state are listed here:</p> <ul style="list-style-type: none"> - The transceiver port is empty. - The transceiver has not established a link to a network device. - The LEDs are turned off. To turn on the LEDs, use the eco-friendly button in the management panel or the NO ECOFRIENDLY LED command in the command line interface.

The LED states for breakout cables are described in Table 32.

Table 32. Link and Activity Status LEDs for 10G Breakout Cables

State	Description
Solid Amber	At least one of the four ports on the breakout cable has established a 10G link to a network device.
Flashing Amber	At least one of the four ports on the breakout cable is sending or receiving data.
Off	<p>Possible causes of this state are listed here:</p> <ul style="list-style-type: none"> - The transceiver slot is empty. - None of the ports on the breakout cable have established a link to a network device. - The LEDs are turned off. To turn on the LEDs, use the eco-friendly button in the management panel or the NO ECOFRIENDLY LED command in the command line interface.

AT-XEM2-1CQ Line Card

The AT-XEM2-1CQ Line Card is shown in Figure 28.

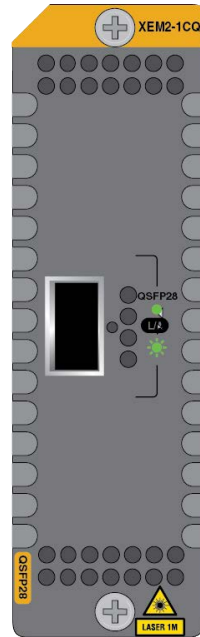


Figure 28. AT-XEM2-1CQ Line Card

Transceiver Port

Here are examples of the types of 100G QSFP28 transceivers supported by the line card:

- ❑ AT-QSFP28-SR4 transceiver - Maximum operating distance of 70m (230 ft) or 100m (328 ft) with 12-strand OM3 or OM4 fiber optic cable, respectively. Requires a MPO pluggable optical connector.
- ❑ AT-QSFP28-LR4 transceiver - Operating range of 2m (6.6 ft) to 10km (6.2 mi). Requires single-mode fiber optic cable with a duplex LC connector.
- ❑ AT-QSFP28-1CU and AT-QSFP28-3CU direct attach cables - Lengths of one and three meters, respectively.

LEDs The LED states for the port in the AT-XEM2-1CQ Line Card are described in Table 33 on page 79.

Table 33. Port Link and Activity Status LED on the AT-XEM2-1CQ Line Card

State	Description
Solid Green	The transceiver has established a 100G link to a network device.
Flashing Green	The transceiver is transmitting or receiving data.
Off	<p>Possible causes of this state are listed here:</p> <ul style="list-style-type: none"> - The transceiver slot is empty. - The transceiver has not established a link to a network device. - The LEDs are turned off. To turn on the LEDs, use the eco-friendly button in the management panel or the NO ECOFRIENDLY LED command in the command line interface.

Chapter 3

Beginning the Installation


The chapter contains the following sections:

- ❑ “Reviewing Safety Precautions” on page 82
- ❑ “Installation Options” on page 87
- ❑ “Choosing a Site for the Chassis” on page 88
- ❑ “Unpacking the Switch” on page 89
- ❑ “Verifying the Accessory Kit” on page 93
- ❑ “Unpacking PWR600 AC and DC Power Supplies” on page 95

Reviewing Safety Precautions


Please review the following safety precautions before beginning the installation procedure.

Note

Safety statements that have the  symbol are translated into multiple languages in the *Translated Safety Statements* document at www.alliedtelesis.com/support.




Warning

Class 1 Laser product.  L1




Warning

Laser Radiation.
Class 1M Laser product.  L10



Warning

Do not stare into the laser beam.  L2




Warning

Do not look directly at the fiber optic ends or inspect the cable ends with an optical lens.  L6




Warning

To prevent electric shock, do not remove the cover. No user-serviceable parts inside. This unit contains hazardous voltages and should only be opened by a trained and qualified technician. To avoid the possibility of electric shock, disconnect electric power to the product before connecting or disconnecting the LAN cables.
 E1



Warning

Do not work on equipment or cables during periods of lightning activity.  E2



Warning

Power cord is used as a disconnection device. To de-energize equipment, disconnect the power cord. ⚡ E3



Warning

Class I Equipment. This equipment must be earthed. The power plug must be connected to a properly wired earth ground socket outlet. An improperly wired socket outlet could place hazardous voltages on accessible metal parts. ⚡ E4

Note

Pluggable Equipment. The socket outlet shall be installed near the equipment and shall be easily accessible. ⚡ E5



Caution

Air vents must not be blocked and must have free access to the room ambient air for cooling. ⚡ E6



Warning

Operating Temperatures. This product is designed for a maximum ambient temperature of 50° degrees C. ⚡ E52

Note

All Countries: Install product in accordance with local and National Electrical Codes. ⚡ E8



Warning

Do not strip more than the recommended amount of wire. Stripping more than the recommended amount can create a safety hazard by leaving exposed wire on the terminal block after installation. ⚡ E10



Warning

When installing this equipment, always ensure that the frame ground connection is installed first and disconnected last. ⚡ E11



Warning

Only trained and qualified personnel are allowed to install or replace this equipment. ⚡ E14



Warning

The equipment must be earthed. The ground screw on the unit must be connected to a properly earthed bonding point. ⚡ E120



Caution

Circuit Overloading: Consideration should be given to the connection of the equipment to the supply circuit and the effect that overloading of circuits might have on overcurrent protection and supply wiring. Appropriate consideration of equipment nameplate ratings should be used when addressing this concern. ⚡ E21



Caution

Risk of explosion if battery is replaced by an incorrect type. Replace only with the same or equivalent type recommended by the manufacturer. Dispose of used batteries according to the manufacturer's instructions.

Attention: Le remplacement de la batterie par une batterie de type incorrect peut provoquer un danger d'explosion. La remplacer uniquement par une batterie du même type ou de type équivalent recommandée par le constructeur. Les batteries doivent être éliminées conformément aux instructions du constructeur. ⚡ E22



Warning

Mounting of the equipment in the rack should be such that a hazardous condition is not created due to uneven mechanical loading. ⚡ E25



Warning

The chassis may be heavy and awkward to lift. Allied Telesis recommends that you get assistance when mounting the chassis in an equipment rack. ⚡ E28

Note

Use dedicated power circuits or power conditioners to supply reliable electrical power to the device. ⚡ E27

**Warning**

This unit might have more than one power cord. To reduce the risk of electric shock, disconnect all power cords before servicing the unit. ⚡ E30

Note

If installed in a closed or multi-unit rack assembly, the operating ambient temperature of the rack environment may be greater than the room ambient temperature. Therefore, consideration should be given to installing the equipment in an environment compatible with the manufacturer's maximum rated ambient temperature (T_{mra}). ⚡ E35

**Caution**

Installation of the equipment in a rack should be such that the amount of air flow required for safe operation of the equipment is not compromised. ⚡ E36

**Warning**

Reliable earthing of rack-mounted equipment should be maintained. Particular attention should be given to supply connections other than direct connections to the branch circuits (e.g., use of power strips). ⚡ E37

**Warning**

This product may have multiple AC power cords installed. To de-energize this equipment, disconnect all power cords from the device. ⚡ E41

**Caution**

An Energy Hazard exists inside this equipment. Do not insert hands or tools into open chassis slots or plugs. ⚡ E44



Warning

This equipment shall be installed in a Restricted Access location.
E45



Caution

The unit does not contain serviceable components. Please return damaged units for servicing. E42



Warning

The temperature of an operational SFP or SFP+ transceiver may exceed 70° C (158° F). Exercise caution when removing or handling transceivers with unprotected hands. E43



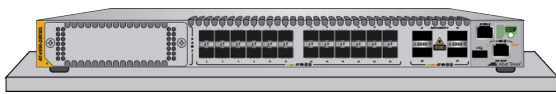
Warning

The AC power supply unit must be connected to a grounded three wire AC source through the power supply cord. E127

Installation Options

Here are installation options for the x950 Switches:

- ❑ The AT-x950-28XSQ and AT-x950-28XTQm Switches support the XEM2 Line Cards. Refer to “Installing XEM2 Ethernet Line Cards” on page 106.
- ❑ The switch has four installation options. Refer to Figure 29.



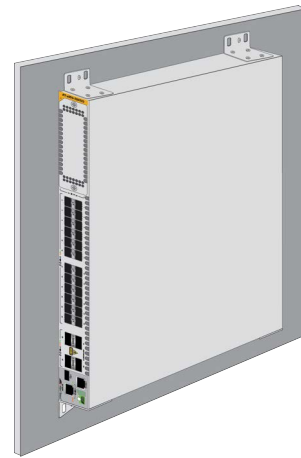
Tabletop



19-inch Equipment Rack with Standard Brackets



19-inch Equipment Rack with Optional AT-RKMT-SL01 Sliding Rack Mount Kit



Wall Installation with Standard Brackets

Figure 29. Installation Options

- ❑ The switch can be installed in an equipment rack with the AT-RKMT-SL01 sliding rack mount kit. Refer to Chapter 8, “Installing the Switch in the AT-RKMT-SL01 Sliding Rack” on page 139.

Note

The standard brackets are included with the switch, The AT-RKMT-SL01 Sliding Rack is purchased separately.

Choosing a Site for the Chassis

Observe these site requirements.

- ❑ If you are installing the device in an equipment rack, check that the rack is safely secured so that it will not tip over. Devices should be installed in the rack starting at the bottom, with the heavier devices near the bottom of the rack.
- ❑ The power outlet should be located near the chassis and be easily accessible.
- ❑ The site should allow for easy access to the ports on the front of the switch, so that you can easily connect and disconnect cables, and view the port LEDs.
- ❑ The site should allow for adequate airflow around the front and rear panels.
- ❑ The ventilation direction in the switch can be either front-to-back or back-to-front, depending on the models of power supplies and fan modules installed in the device. Refer to “AT-PWR600 and AT-PWR600R AC and DC Power Supplies” on page 44 and “AT-FAN05 and AT-FAN05R Fan Modules” on page 52 for further information.
- ❑ The site should not expose the switch to moisture or water.
- ❑ The site should be a dust-free environment.
- ❑ The site should include dedicated power circuits or power conditioners to supply reliable electrical power to the network devices.
- ❑ Copper cabling should not be exposed to sources of electrical noise, such as radio transmitters, broadband amplifiers, power lines, electric motors, or fluorescent fixtures.
- ❑ Switch ports are suitable for intra-building connections, or where non-exposed cabling is required.
- ❑ If you are installing the device in a wiring or utility box, verify that there is adequate airflow to protect the device from overheating.

Unpacking the Switch

To unpack the switch from its shipping box, perform the following procedure:

1. Remove the accessories and documents from the accessory box partition. Refer to Figure 30.

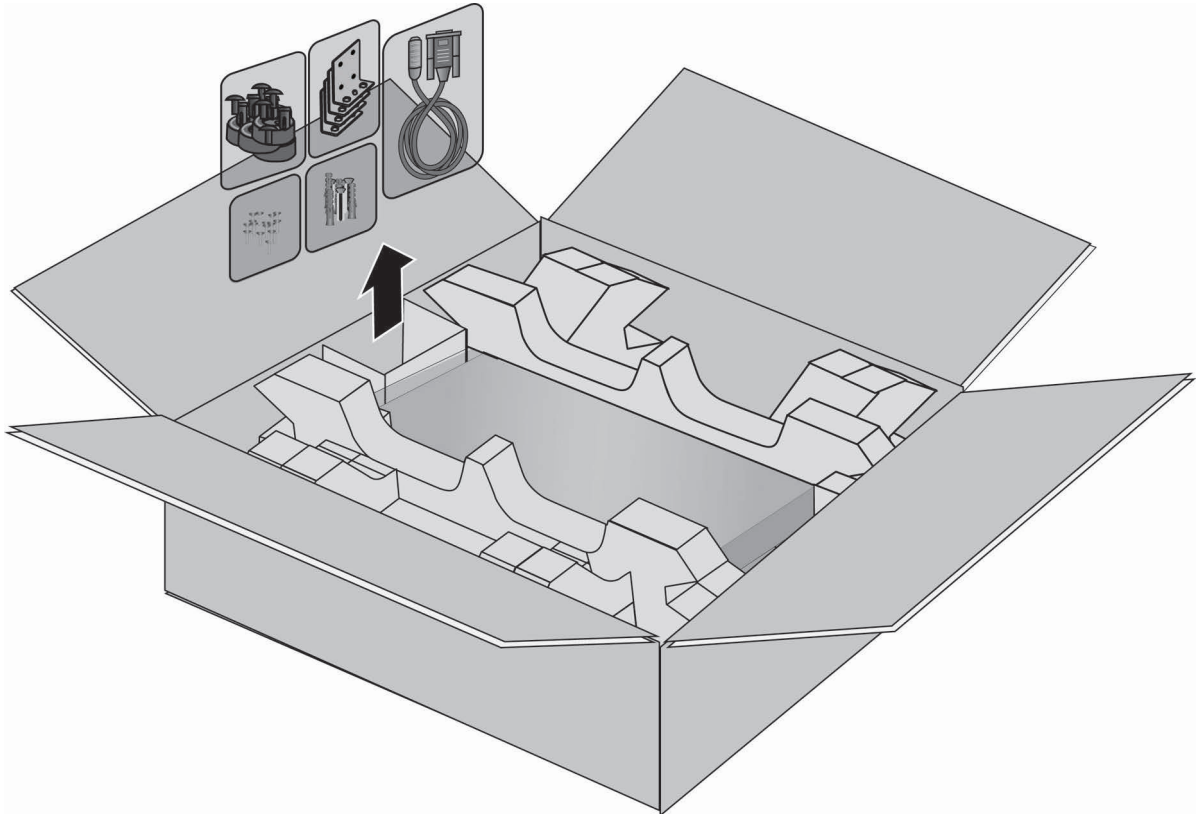


Figure 30. Removing Accessories

2. Remove the accessory box partition. Refer to Figure 31 on page 90.

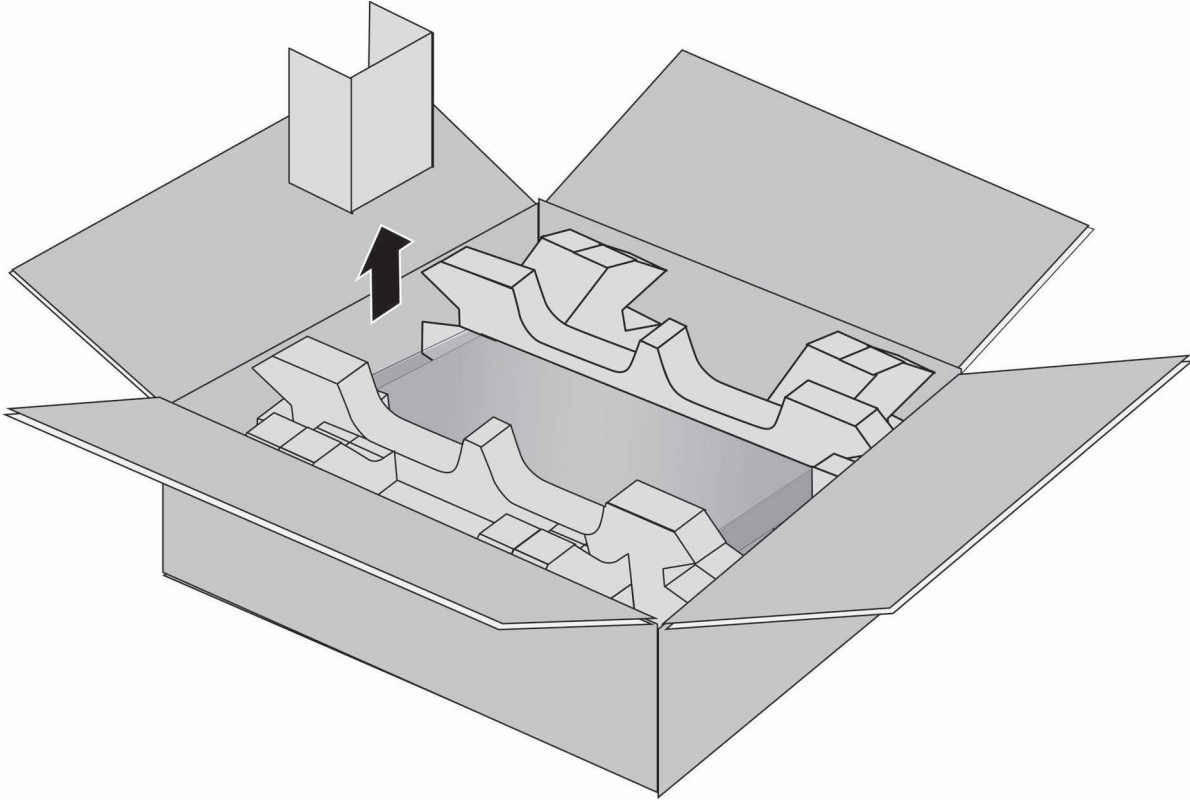


Figure 31. Removing the Shipping Box Partition

3. Lift the switch from the shipping box and place it on a level, secure table. Refer to Figure 32 on page 91.



Warning

The device is heavy. Always ask for assistance before moving or lifting it to avoid injure yourself or damage the equipment. *GE* E122

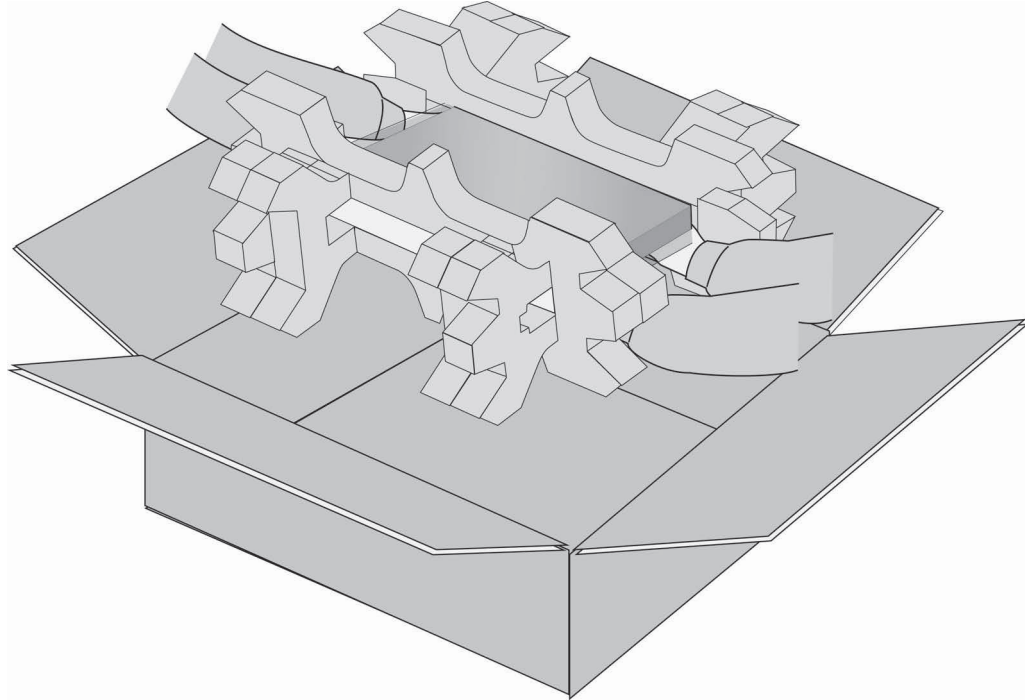


Figure 32. Lifting the Switch from the Shipping Box

4. Remove the switch from the shipping end-caps and protective bag. Refer to Figure 33.

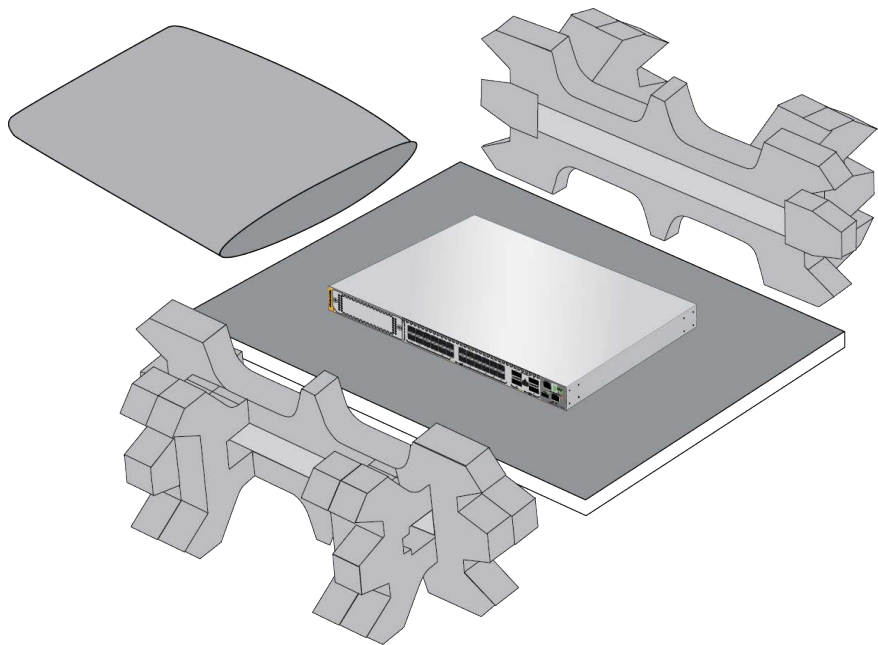


Figure 33. Removing the Switch from the Shipping End-caps and Protective Bag

5. Visually inspect the product for damage.
6. Visually inspect the front panel for the components shown in Figure 1 on page 20 and Figure 2 on page 21.
7. Verify that there are two pre-installed FAN05 fan modules in FAN A and FAN B slots on the rear panel. Refer to Figure 3 on page 21 and “AT-FAN05 and AT-FAN05R Fan Modules” on page 52.

Note


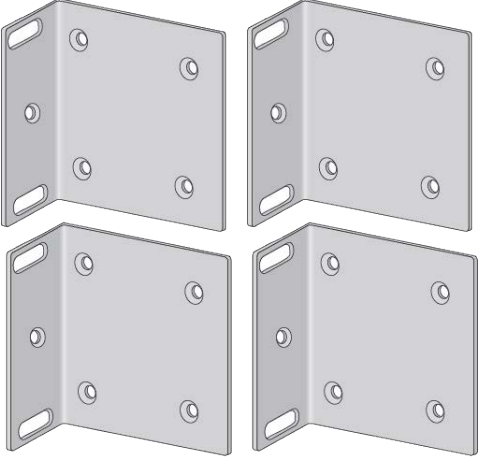

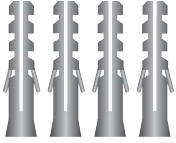

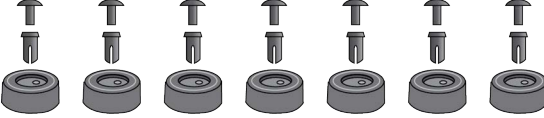
Do not power on the switch if it is missing a fan module.

8. Go to “Verifying the Accessory Kit” on page 93.

Verifying the Accessory Kit

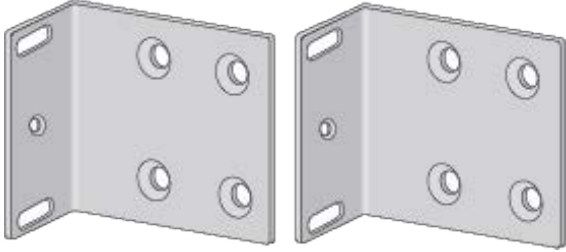

Table 34 lists the accessory items included with the switch.

Table 34. Accessory Kit

Item	Description
	<p>One 2 m (6.6 ft) local management cable with RJ-45 (8P8C) and DB-9 (D-sub 9-pin) connectors.</p>
	<p>Four standard mounting brackets</p> <p>Note For the AT-x950-28XSQ and AT-x950-28XTQm Switches, these brackets are for both equipment rack and wall mounting.</p> <p>Note For the AT-x950-52XSQ and AT-x950-52XTQm Switches, these brackets are only for wall mounting. For equipment rack mounting, use the rack mounting brackets shown in Table 35 on page 94.</p>
	<p>Sixteen M3x6mm screws for the standard mounting brackets</p>
	<p>Four anchors for concrete walls: Length: 29.6mm (1.2 in.) Diameter: 4mm (0.2 in.)</p>
	<p>Four screws for wood or concrete walls: Length: 32.6mm (1.3 in.) Diameter: 4mm (0.2 in.)</p>
	<p>Seven bumper feet</p>

In addition to the accessory kit in Table 34 on page 93, the AT-x950-52XSQ and AT-x950-52XTQm Switches come with the rack mounting brackets and screws shown in Table 35.

Table 35. Additional Accessory Kit for the AT-x950-52XSQ and AT-x950-52XTQm Switches

Item	Description
	<p>Two rack mounting brackets for the AT-x950-52XSQ and AT-x950-52XTQm Switches</p>
	<p>Eight M4x7mm screws for the rack mounting brackets</p>

Note

If any item is missing or damaged, contact your Allied Telesis sales representative for assistance.

After unpacking the switch and verifying the accessory kit, go to “Unpacking PWR600 AC and DC Power Supplies” on page 95.

Unpacking PWR600 AC and DC Power Supplies

To unpack AT-PWR600, AT-PWR600R, AT-PWR600-80, and AT-PWR600R-80 Power Supplies, perform the following procedure:

1. Remove the power cord and any documents from the accessory box partition. Refer to Figure 34.

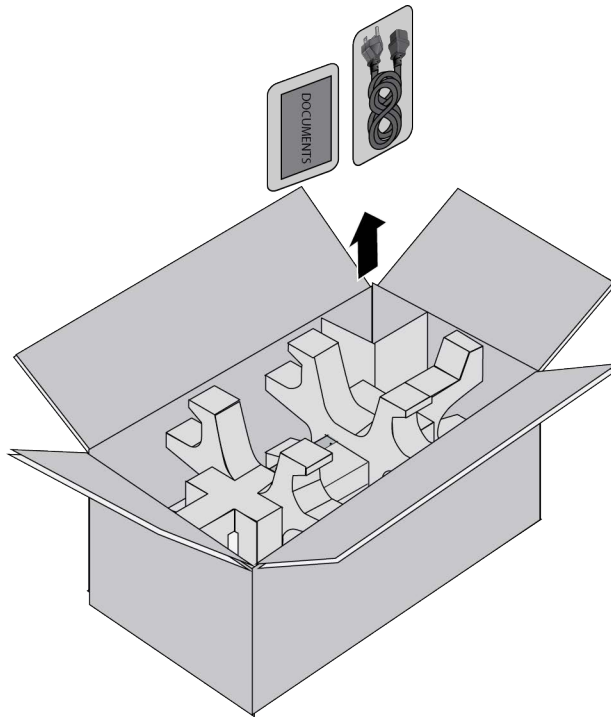


Figure 34. Removing the Power Cord and Documents from the Power Supply Shipping Box

Note

The AT-PWR600-80 and AT-PWR600R-80 DC Power Supplies do not come with power cords.

2. Remove the partition from the shipping box. Refer to Figure 35.

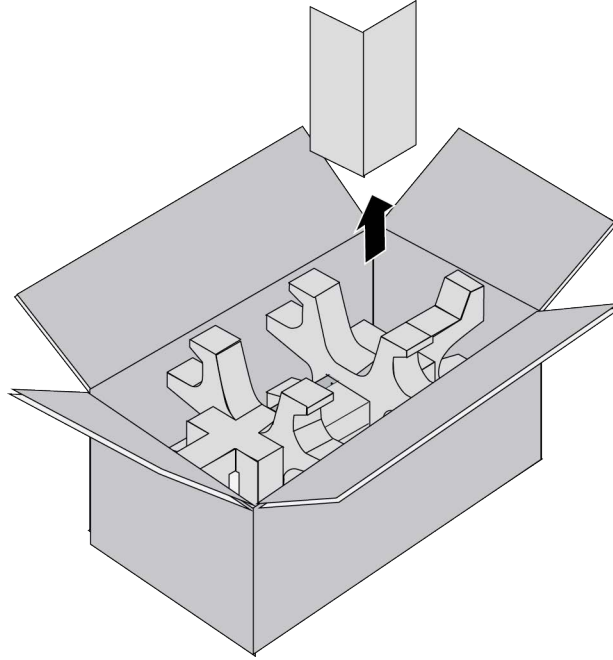


Figure 35. Removing the Partition from the Power Supply Shipping Box

3. Lift the power supply from the shipping box and place it on a level, secure table. Refer to Figure 36 on page 97.



Warning

The device is heavy. Always ask for assistance before moving or lifting it to avoid injure yourself or damage the equipment. *GE* E122

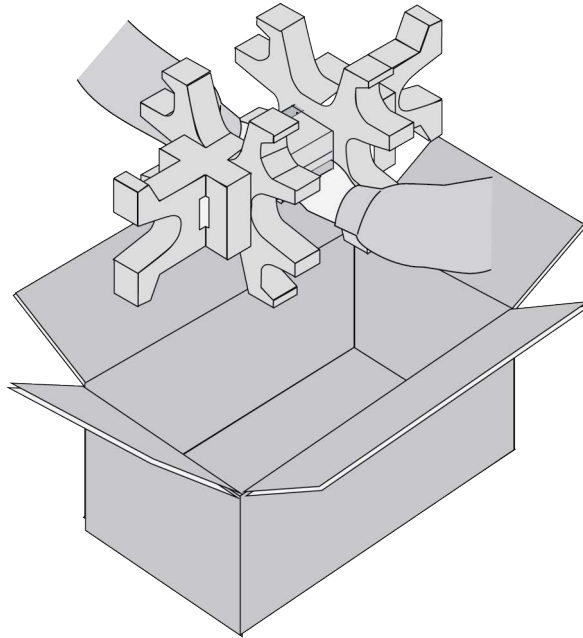


Figure 36. Removing the Power Supply from the Shipping Box

4. Remove the power supply from the shipping end-caps and protective shipping bag. Refer to Figure 37.

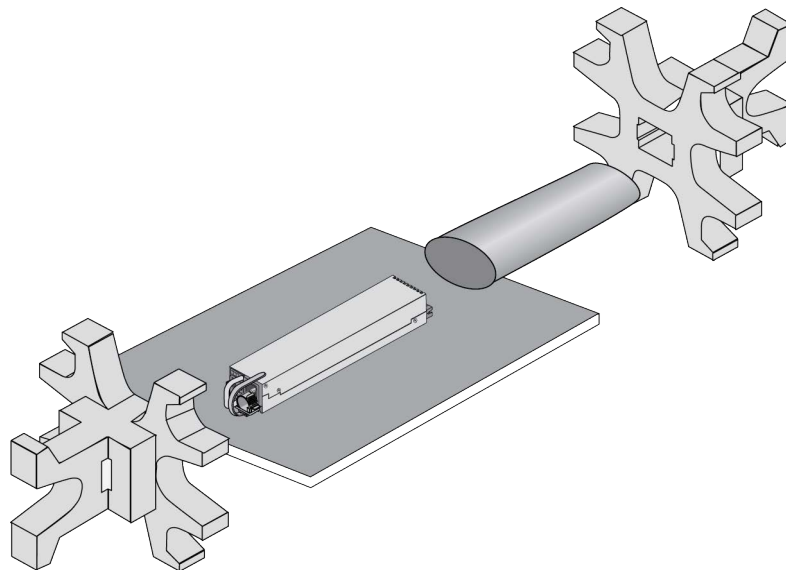


Figure 37. Removing the Power Supply from the Shipping End-caps and Protective Bag

5. Visually inspect the product for damage.
6. After unpacking the switch and power supplies, go to Chapter 4, “Installing Power Supplies and XEM2 Line Cards” on page 99.

Chapter 4

Installing Power Supplies and XEM2 Line Cards

This chapter has the following procedures:


- ❑ “Installing AT-PWR600 and AT-PWR600R AC Power Supplies” on page 100
- ❑ “Installing AT-PWR600-80 and AT-PWR600R-80 DC Power Supplies” on page 104
- ❑ “Installing XEM2 Ethernet Line Cards” on page 106

Installing AT-PWR600 and AT-PWR600R AC Power Supplies

This section contains the procedure for installing AT-PWR600 and AT-PWR600R AC Power Supplies in the switch. For background information, refer to “AT-PWR600 and AT-PWR600R AC and DC Power Supplies” on page 44. For a list of power supply components, refer to “Unpacking PWR600 AC and DC Power Supplies” on page 95.



Warning

The device is heavy. Use both hands to lift it. You might injure yourself or damage the device if you drop it.  E94



Caution

The device can be damaged by electrostatic discharge (ESD). Be sure to observe all standard electrostatic discharge (ESD) precautions, such as wearing an antistatic wrist strap, to guard against damaging the device.

After installing the power supplies and XEM2 Line Card, go to one of the following chapters:

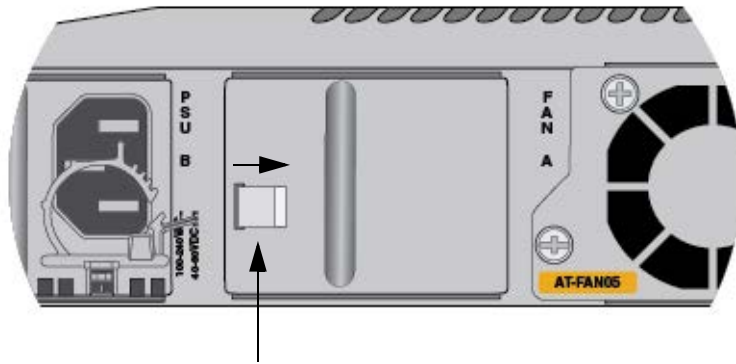
- ❑ Chapter 5, “Installing the Switch on a Table” on page 111
- ❑ Chapter 6, “Installing the Switch in an Equipment Rack” on page 115
- ❑ Chapter 7, “Installing the Switch on a Wall” on page 123
- ❑ Chapter 8, “Installing the Switch in the AT-RKMT-SL01 Sliding Rack” on page 139

To install the AT-PWR600 or AT-PWR600R AC Power Supply, perform the following procedure:

1. Choose a slot for the power supply. The two power supply slots are labeled PSU A and PSU B on the left side of the rear panel.

If you are installing only one power supply, you can install it in either slot. Allied Telesis recommends PSU A because that slot does not come with a blank power supply panel.

2. If there is already a power supply in PSU A, remove the blank panel from PSU B slot by pressing the release tab to the right and sliding the panel from the switch. Refer to Figure 38 on page 101.



Release Tab

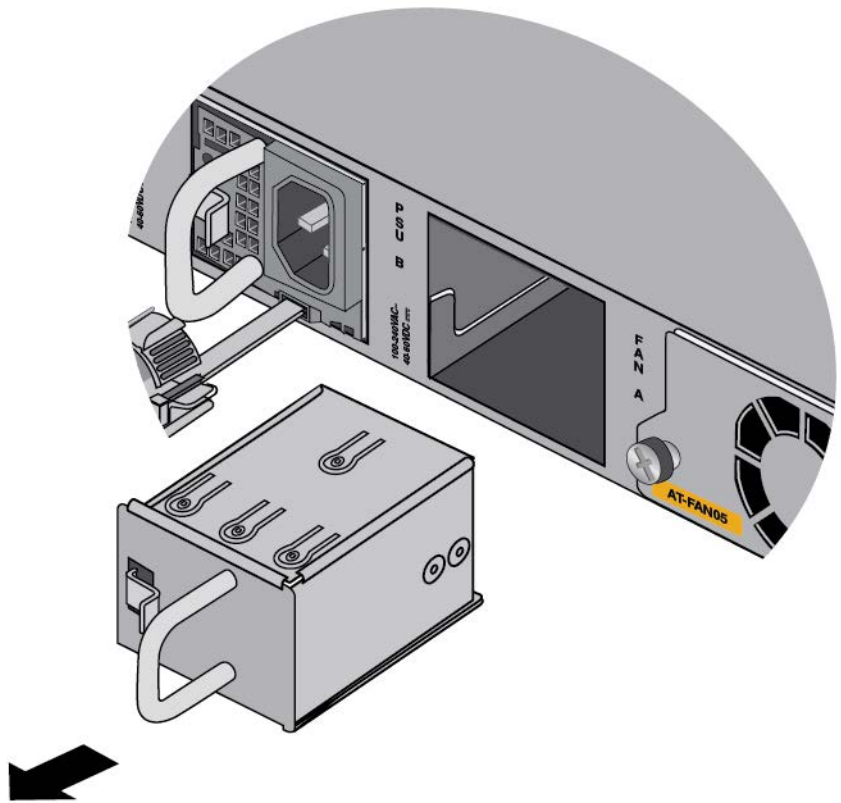


Figure 38. Removing the Blank Power Supply Panel from Slot PSU B

3. Carefully align the power supply in the slot and slide it into the slot. Figure 39 shows the module aligned for the PSU A slot.

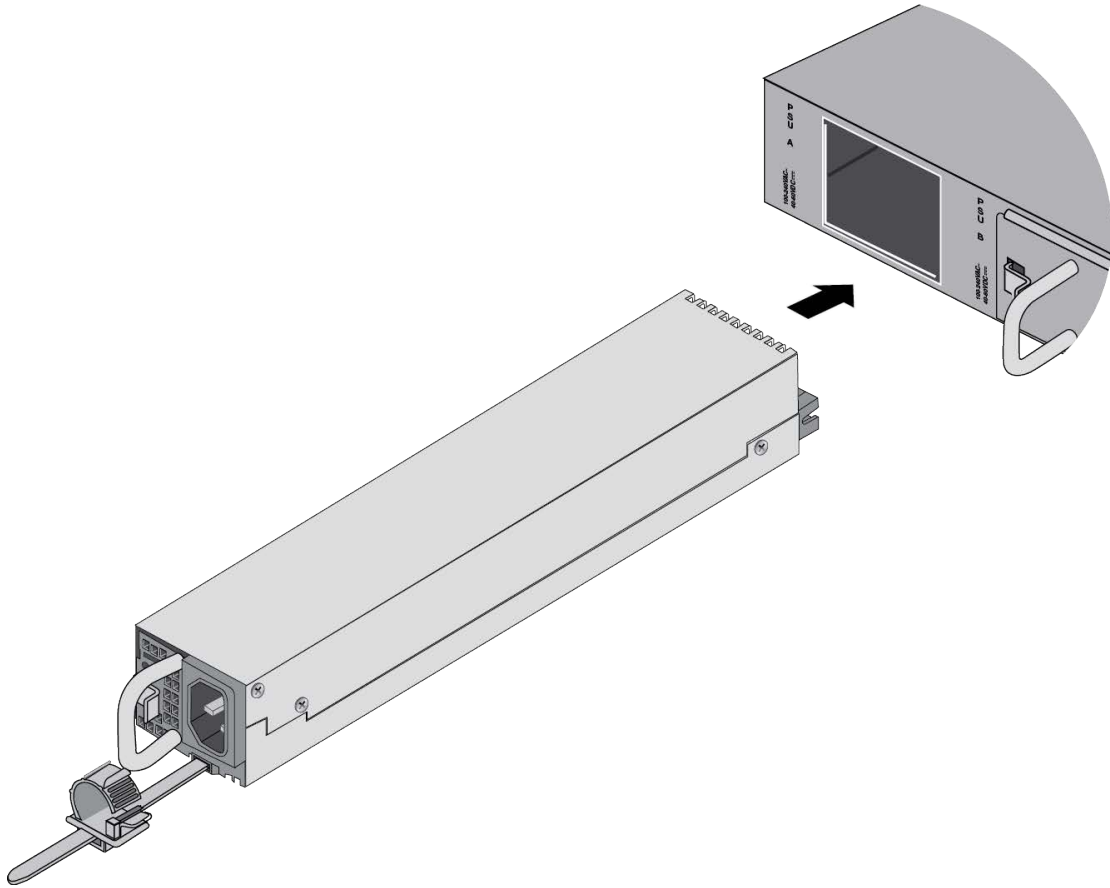


Figure 39. Sliding the AT-PWR600 or AT-PWR600R AC Power Supply into the Chassis

4. When the power supply makes contact with the connector inside the switch, gently press on its faceplate to seat it on the connector. Refer to Figure 40 on page 103.

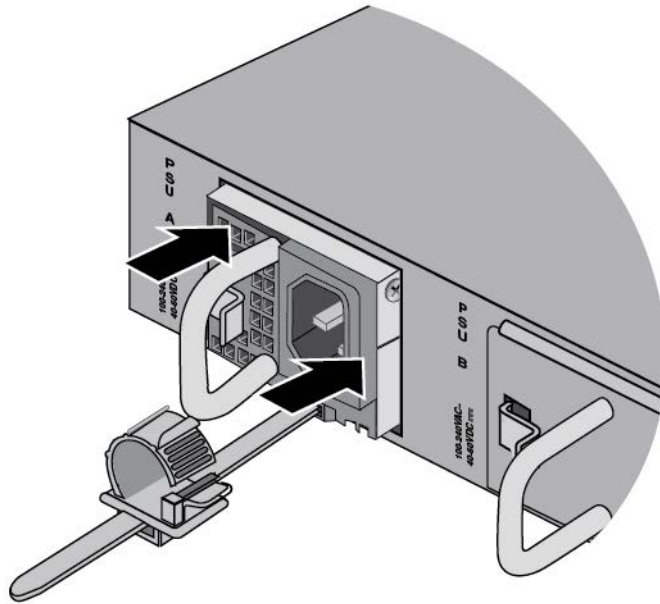


Figure 40. Seating the Power Supply on the Internal Connector


5. Visually inspect the power supply to be sure that its faceplate is flush against the rear panel of the chassis.
6. If you purchased two AC power supplies for the switch, repeat this procedure to install the second unit.
7. If you purchased a DC power supply as the second power supply, go to “Installing AT-PWR600-80 and AT-PWR600R-80 DC Power Supplies” on page 104.
8. To install an XEM2 Line Card, go to “Installing XEM2 Ethernet Line Cards” on page 106.

Installing AT-PWR600-80 and AT-PWR600R-80 DC Power Supplies

This section contains the procedure for installing AT-PWR600-80 and AT-PWR600R-80 DC Power Supplies in the switch. For background information, refer to “AT-PWR600 and AT-PWR600R AC and DC Power Supplies” on page 44. For a list of power supply components, refer to “Unpacking PWR600 AC and DC Power Supplies” on page 95.



Warning

The device is heavy. Use both hands to lift it. You might injure yourself or damage the device if you drop it.  E94



Caution

The device can be damaged by electrostatic discharge (ESD). Be sure to observe all standard electrostatic discharge (ESD) precautions, such as wearing an antistatic wrist strap, to guard against damaging the device.

After installing the power supplies and XEM2 Line Card, go to one of the following chapters:

- ❑ Chapter 5, “Installing the Switch on a Table” on page 111
- ❑ Chapter 6, “Installing the Switch in an Equipment Rack” on page 115
- ❑ Chapter 7, “Installing the Switch on a Wall” on page 123
- ❑ Chapter 8, “Installing the Switch in the AT-RKMT-SL01 Sliding Rack” on page 139

To install the AT-PWR600-80 or AT-PWR600R-80 DC Power Supply, perform the following procedure:

1. Choose a slot for the power supply. The two power supply slots are labeled PSU A and PSU B on the left side of the rear panel.

If you are installing only one power supply, you can install it in either slot. Allied Telesis recommends PSU A because that slot does not come with a blank power supply panel.
2. If there is already a power supply in PSU A, remove the blank panel from PSU B slot by pressing the release tab to the right and sliding the panel from the switch. Refer to Figure 38 on page 101.
3. Carefully align the power supply in the slot and slide it into the slot. Figure 41 on page 105 shows the module aligned for the PSU A slot.

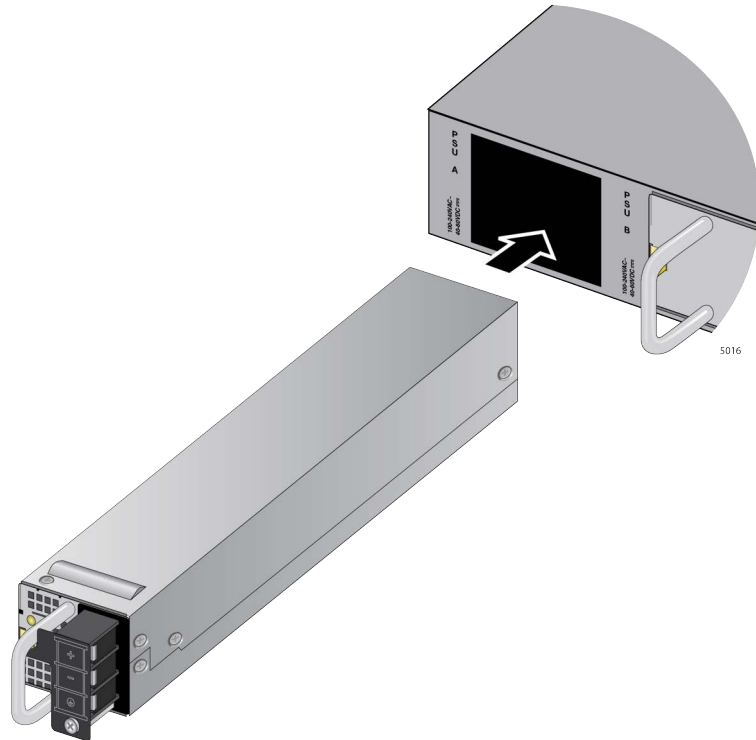


Figure 41. Sliding the AT-PWR600 DC Power Supply into the Chassis

4. When the power supply makes contact with the connector inside the switch, gently press on its faceplate to seat it on the connector.
5. Visually inspect the power supply to verify that its faceplate is flush with the rear panel of the chassis.
6. If you purchased two DC power supplies for the switch, repeat this procedure to install the second unit.
7. If you purchased an AC power supply as the second power supply, go to “Installing AT-PWR600 and AT-PWR600R AC Power Supplies” on page 100.
8. To install an XEM2 Line Card in the AT-x950-28XSQ or AT-x950-28XTQm Switch, go to “Installing XEM2 Ethernet Line Cards” on page 106.

Note

Depending on the installation site, it may be easier to connect the ground wire and DC positive and negative power wires to the DC power supply module before installing the switch on a table, wall, or equipment rack. For wiring instructions, refer to “Wiring and Powering on AT-PWR600-80 and AT-PWR600R-80 DC Power Supplies” on page 167.

Installing XEM2 Ethernet Line Cards

This section contains the procedure for installing an XEM2 Line Card in the expansion slot in the front panel of the AT-x950-28XSQ and AT-x950-28XTQm Switches. For background information, refer to Chapter 2, “XEM2 Ethernet Line Cards” on page 61. The illustrations show the XEM2-12XT Line Card. The procedure is the same for all line cards.

Note

The AT-x950-52XSQ and xAT-950-52XTQm Switches do not support XEM2 Line Cards.

**Caution**

The device can be damaged by static electricity. Be sure to follow proper anti-static precautions when installing the device. Allied Telesis recommends using a properly grounded wrist strap or other personal anti-static device and an anti-static mat.

To install an XEM2 Line Card, perform the following procedure:

1. Using a #2 Phillips-head screwdriver, loosen the two captive screws on the blank expansion slot panel and remove it from the switch. Refer to Figure 42.

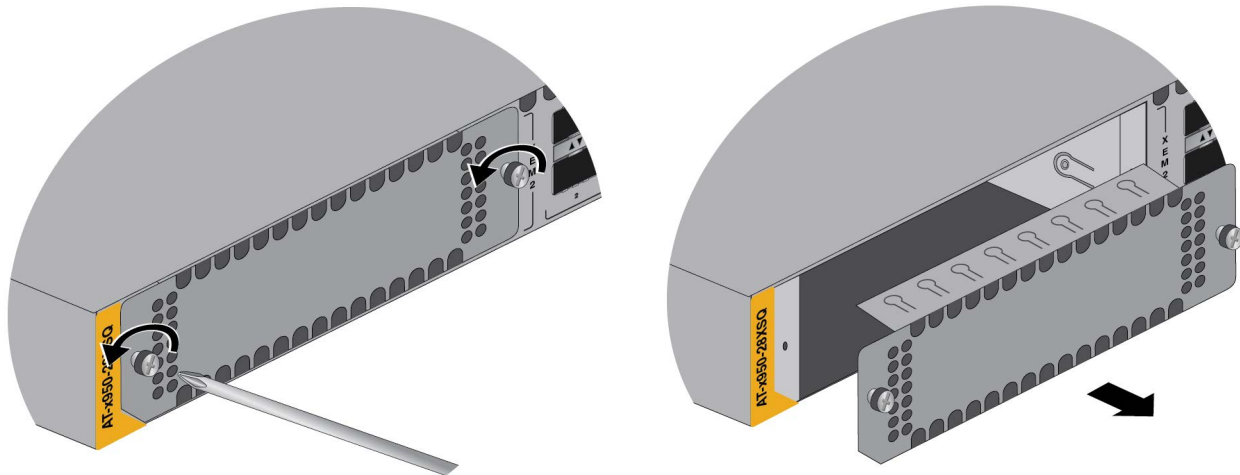


Figure 42. Removing the Blank Line Card Cover

- Carefully remove the line card from its shipping container and anti-static bag. Refer to Figure 43.

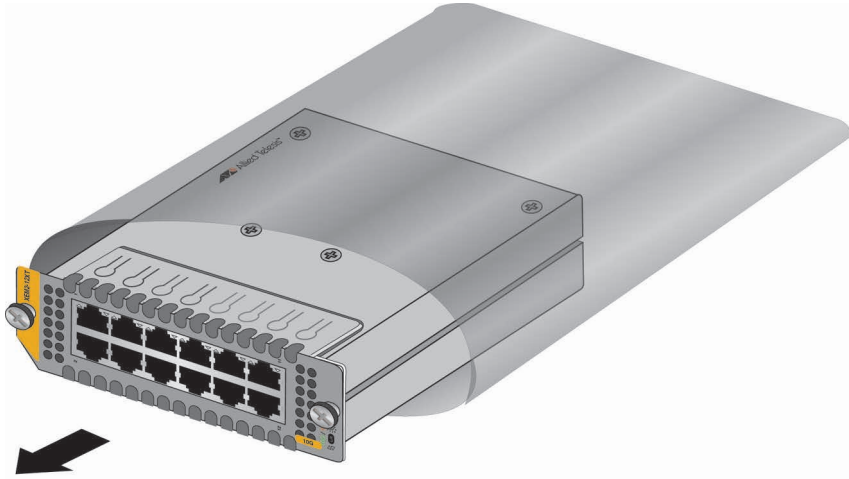


Figure 43. Removing the XEM2 Line Card from the Anti-static Bag

- Position the line card with the notch on the faceplate in the bottom left corner, as shown in Figure 44, and carefully slide it into the slot.

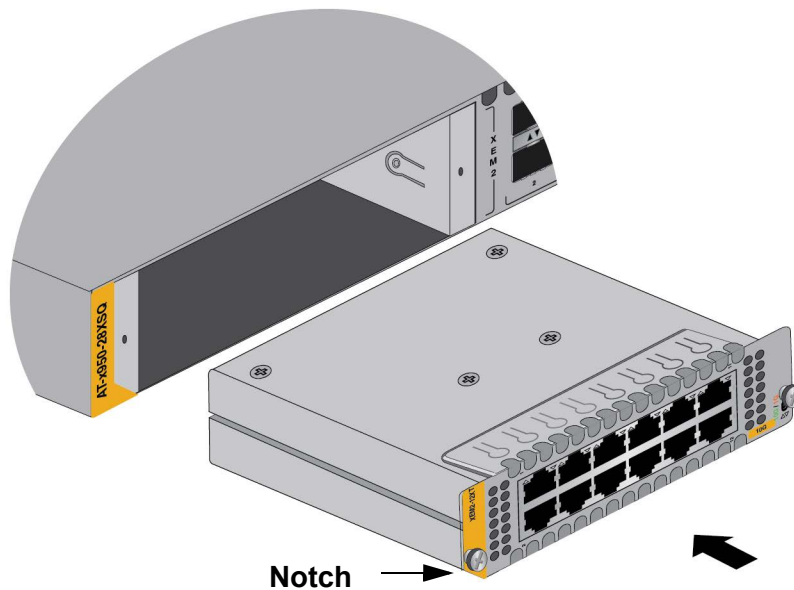


Figure 44. Sliding the XEM2 Line Card into the Slot



Caution

Do not use excessive force when seating the module, because this may damage the system or the module. If the module resists seating, remove it from the system, realign it, and try again. E47

4. When the line card makes contact with the internal connector in the switch, gently press on the sides of its faceplate to seat it on the connector. Refer to Figure 45.

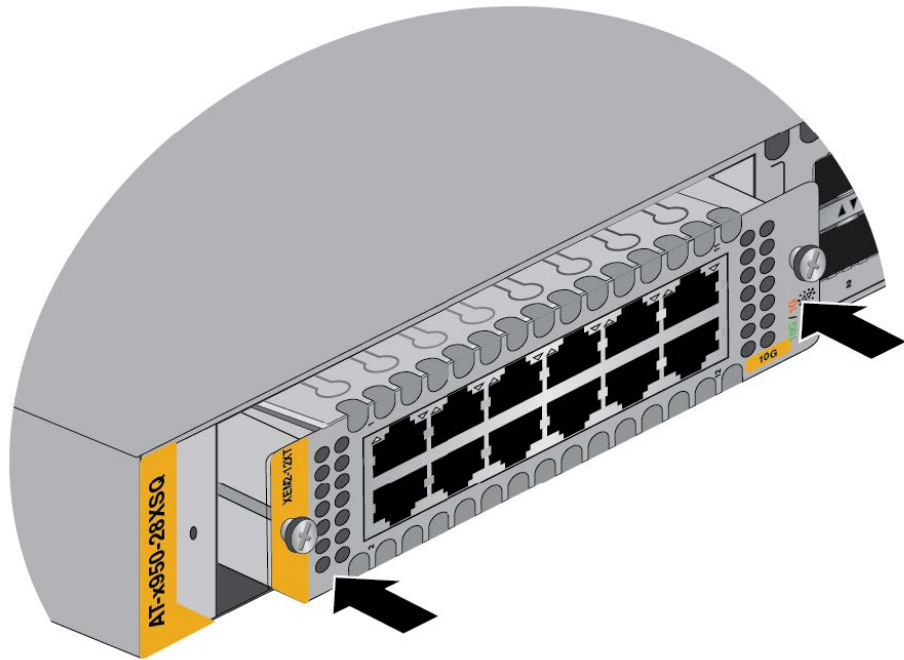


Figure 45. Seating the XEM2 Line Card in the Expansion Slot

5. Visually inspect the line card to verify that its faceplate is flush against the front panel of the switch.
6. Tighten the two captive screws on the card to secure it in the switch. Refer to Figure 46 on page 109.

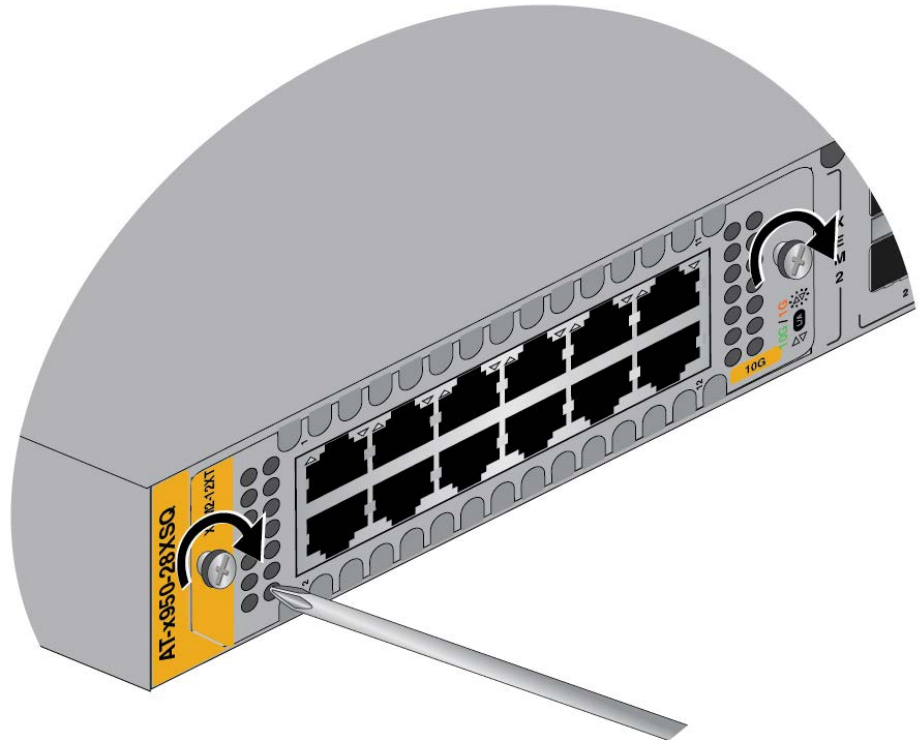


Figure 46. Tightening the Two Captive Screws on the XEM2 Line Card

7. After installing the power supplies and XEM2 Line Card, go to one of the following chapters:
 - ❑ Chapter 5, “Installing the Switch on a Table” on page 111
 - ❑ Chapter 6, “Installing the Switch in an Equipment Rack” on page 115
 - ❑ Chapter 7, “Installing the Switch on a Wall” on page 123
 - ❑ Chapter 8, “Installing the Switch in the AT-RKMT-SL01 Sliding Rack” on page 139

Chapter 5

Installing the Switch on a Table

This chapter contains the instructions for installing the switch on a table or desktop.



Warning

Switches should not be stacked on a table or desktop. They could present a physical safety hazard if you need to move or replace switches. ⚡ E91



Warning

The device is heavy. Always ask for assistance when moving or lifting it to avoid injuring yourself or damaging the equipment. ⚡ E122

The switch comes with seven bumper feet in the accessory kit. The feet, which are reusable, are used when installing the switch on a table. If they are already assembled, disassemble them by removing the rivets and rivet housings from the bumper feet. Refer to Figure 47.

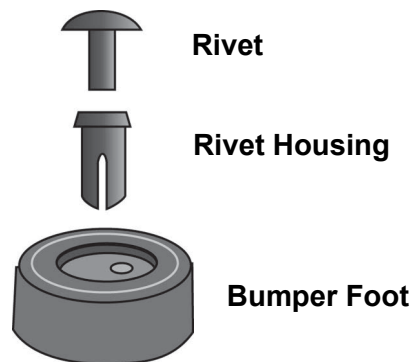


Figure 47. Parts of the Bumper Feet

The holes in the base of the switch for the bumper feet are shown in Figure 48 on page 112.

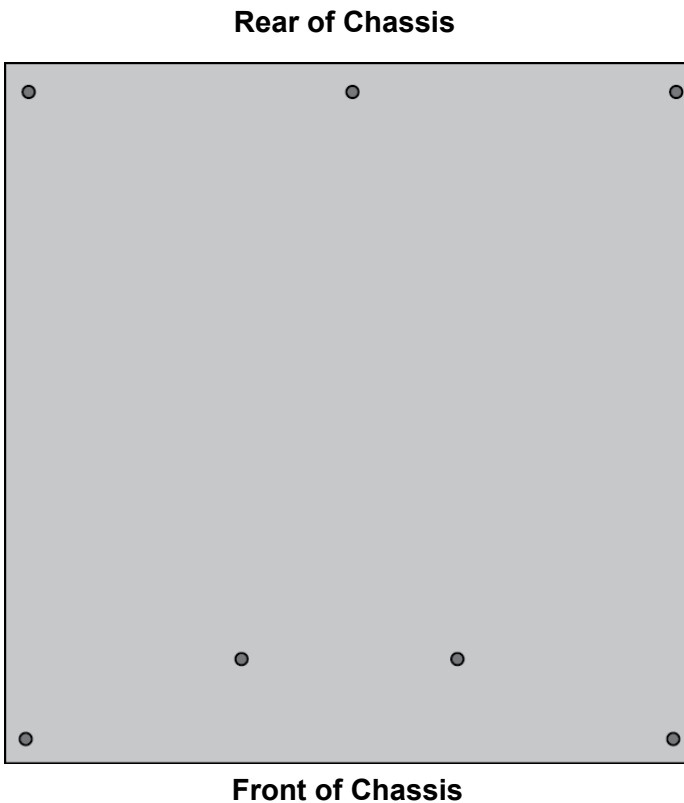


Figure 48. Holes for Bumper Feet

Note

The following procedure assumes that you have already reviewed the information and performed the procedures in Chapter 3, “Beginning the Installation” on page 81.

To install the switch on a table, perform the following procedure:

1. Place the switch upside down on a table.
2. Inset a rivet housing into a bumper foot. Refer to Figure 49.

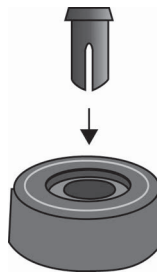


Figure 49. Inserting the Rivet Housing into the Bumper Foot

3. Place the bumper foot onto one of the holes in the base of the switch. Refer to Figure 50.

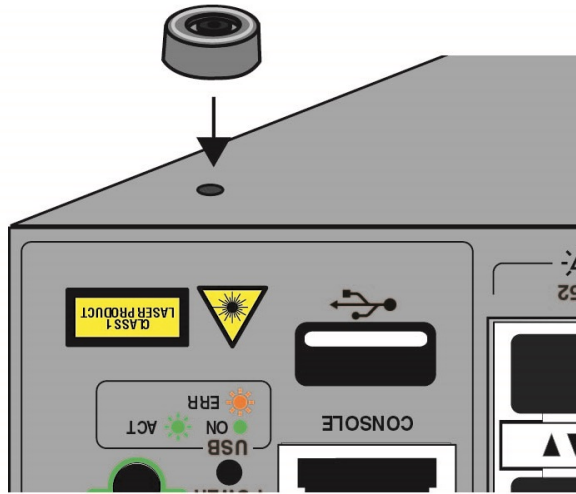


Figure 50. Placing the Bumper Foot on a Base Corner Hole

4. Insert the rivet to secure the bumper foot to the base. Refer to Figure 51.

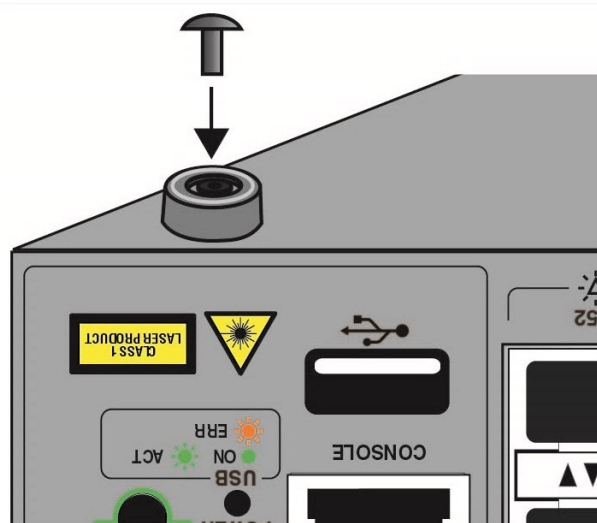


Figure 51. Inserting the Rivet into the Bumper Foot

5. Repeat steps 2 to 4 to install the remaining bumper feet.
6. Turn the switch over and place it on a flat, secure desk or table, leaving ample space around it for ventilation.

7. Do one of the following:
 - ❑ To install AC power supplies, go to “Installing AT-PWR600 and AT-PWR600R AC Power Supplies” on page 100.
 - ❑ To install DC power supplies, go to “Installing AT-PWR600-80 and AT-PWR600R-80 DC Power Supplies” on page 104.
 - ❑ To install an XEM2 Ethernet Line Card, go to “Installing XEM2 Ethernet Line Cards” on page 106.
 - ❑ If all the hardware components are installed, go to Chapter 9, “Verifying and Configuring the Switch” on page 163.

Chapter 6

Installing the Switch in an Equipment Rack

This chapter contains instructions for installing the switch in a standard 19-inch equipment rack. The procedures are listed here:

- “Beginning the Installation” on page 116
- “Removing the Bumper Feet” on page 118
- “Installing the Switch” on page 119

Beginning the Installation

This chapter contains the procedure for installing the switch in a standard 19-inch equipment rack, with the brackets included with the unit.

Required Items

The following items are required to install the switch in an equipment rack:

- Two equipment rack brackets (included with the switch)
- Eight M4x6mm bracket screws (included with the switch)
- Cross-head screwdriver (not provided)
- Four standard equipment rack screws (not provided)

Switch Orientations in the Equipment Rack

Figure 52 identifies the holes for the standard brackets on the AT-x950-28XSQ and AT-x950-28XTQm Switches.

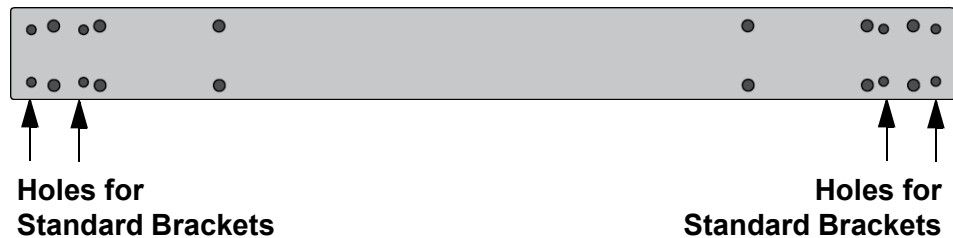


Figure 52. Holes for the Equipment Rack Brackets on the AT-x950-28XSQ and AT-x950-28XTQm Switches

Figure 53 identifies the holes for the equipment rack brackets on the AT-x950-52XSQ and AT-x950-52XTQm Switches.

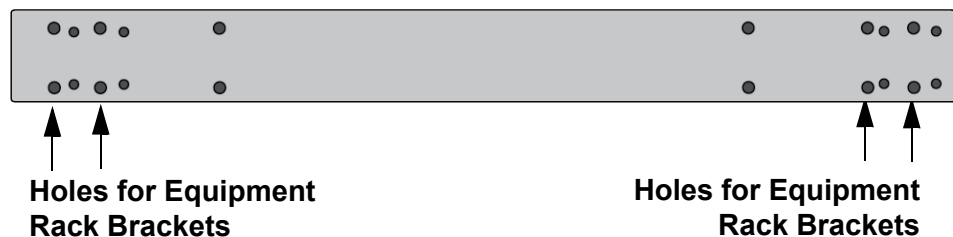


Figure 53. Holes for the Equipment Rack Brackets on the AT-x950-52XSQ and AT-x950-52XTQm Switches

You can install the switch with its front panel flush with or extending in front of the equipment rack. The illustrations in Figure 54 show the possible switch orientations in the equipment rack.



Figure 54. Switch Orientations in an Equipment Rack

Removing the Bumper Feet

The bumper feet included with the switch should not be used when installing the device in an equipment rack. If they are already installed, perform the following procedure to remove them:

1. Place the switch upside down on a level, secure surface.
2. Use a small flat-head screwdriver to gently pry the feet from the bottom of the switch. Refer to Figure 55.

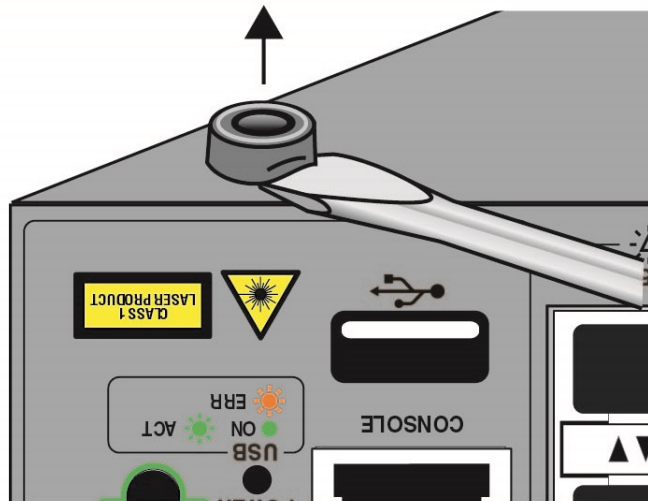


Figure 55. Removing the Bumper Feet

3. Turn the switch back over.
4. Go to “Installing the Switch” on page 119.

Installing the Switch

Please review the information and perform the procedures in Chapter 3, “Beginning the Installation” on page 81 before installing the switch.



Caution

The chassis may be heavy and awkward to lift. Allied Telesis recommends that you get assistance when mounting the chassis in an equipment rack. *See* E28

Note

The switch can be installed in an equipment rack with the RKMT-SL01 Sliding Rack Mount Kit. For instructions, refer to the *RKMT-SL01 Sliding Rack Mount Kit Installation Guide*.

Note

The switch comes with four brackets. Installing the device in an equipment rack requires only two brackets. All four brackets are used when installing the switch on a wall.

To install the switch in a 19-inch equipment rack, perform the following procedure:

1. Place the unit on a level, secure surface.
2. If you have not chosen an orientation for the switch in the equipment rack, review “Switch Orientations in the Equipment Rack” on page 116.
3. Attach two rack mount brackets to the sides of the switch in the selected positions as shown in Figure 56 on page 120. The illustration in Figure 57 on page 120 shows the installation of the brackets so that the front panel will be even with the front of the equipment rack.
 - For the AT-x950-28XSQ and AT-x950-28XTQm Switches, use two of the four standard brackets with eight of the M3x6mm screws listed in Table 34 on page 93.
 - For the AT-x950-52XSQ and AT-x950-52XTQm Switches, use two rack mounting brackets with the eight M4x7mm screws listed in Table 35 on page 94.



Figure 56. Attaching the Equipment Rack Brackets

4. Have another person hold the switch in the equipment rack while you secure it using standard equipment rack screws (not provided). Refer to Figure 57.

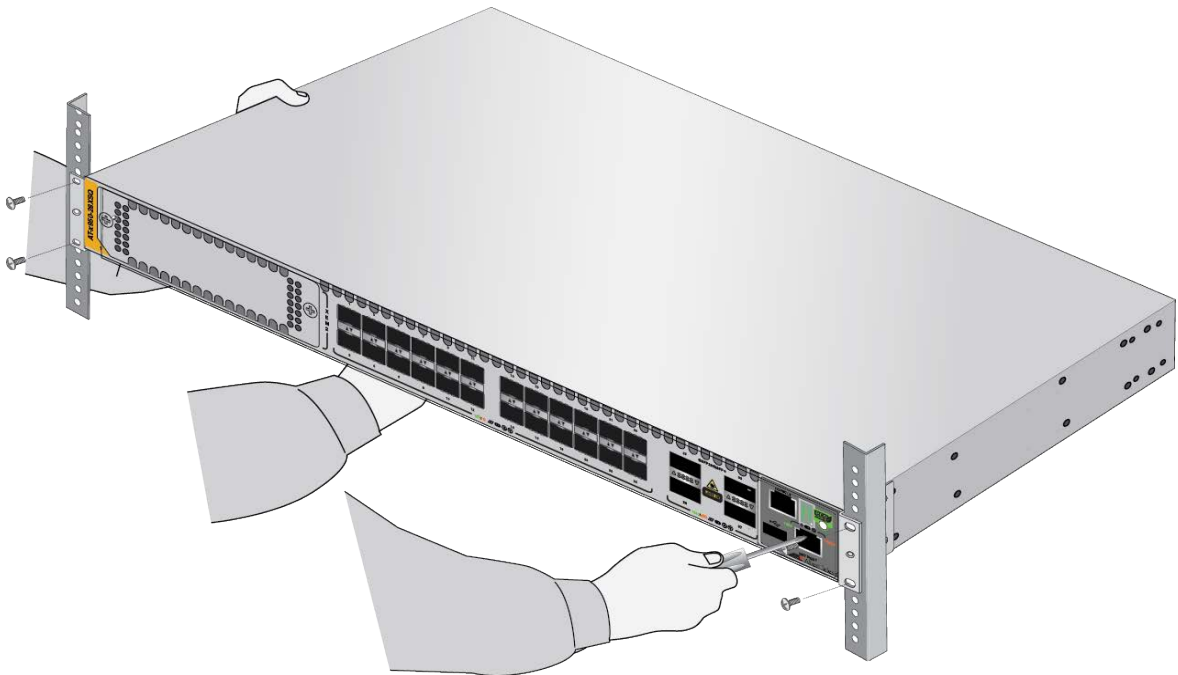


Figure 57. Installing the Switch in an Equipment Rack

5. Do one of the following:
 - ❑ To install power supplies, go to “Installing AT-PWR600 and AT-PWR600R AC Power Supplies” on page 100.
 - ❑ To install an XEM2 Ethernet Line Card, go to “Installing XEM2 Ethernet Line Cards” on page 106.
 - ❑ If all the components are installed, go to Chapter 9, “Verifying and Configuring the Switch” on page 163.

Chapter 7

Installing the Switch on a Wall

The procedures in this chapter are listed here:

- “Switch Orientations on a Wall” on page 124
- “Recommended Minimum Wall Area Dimensions” on page 125
- “Plywood Base for a Wall with Wooden Studs” on page 127
- “Installation Guidelines” on page 129
- “Installing the Plywood Base” on page 131
- “Installing the Switch on the Plywood Base” on page 132
- “Installing the Switch on a Concrete Wall” on page 135

Switch Orientations on a Wall

You can install the switch on a wall with the front panel on the left or right, as shown in Figure 58. Do not install it with the front panel on the top or bottom.

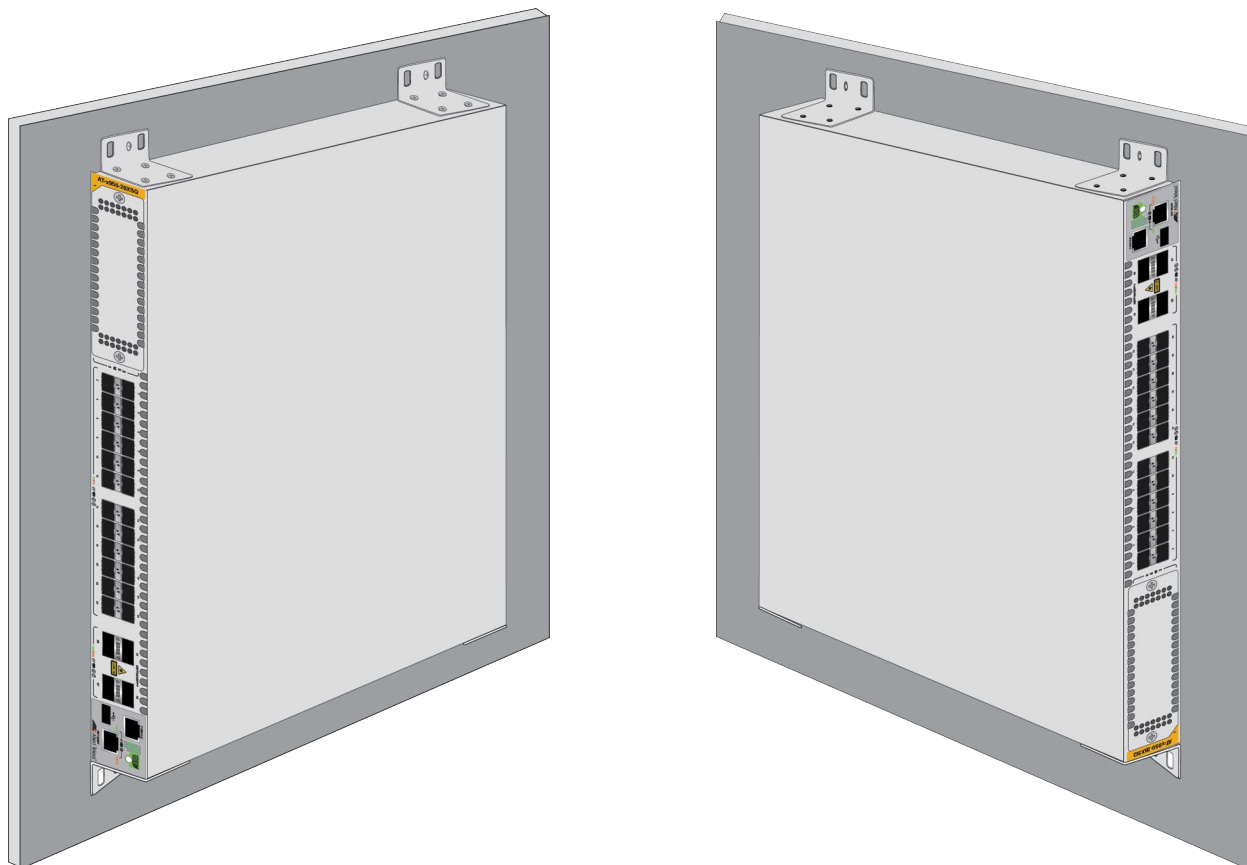


Figure 58. Positions of the Switch on the Wall

Recommended Minimum Wall Area Dimensions

The recommended minimum dimensions for the reserved wall area for the switch are listed here:

- ❑ Width: 96 centimeters (36 inches)
- ❑ Height: 58 centimeters (23 inches)

Figure 59 and Figure 60 on page 126 illustrate the recommended positions of the switch in the reserved area when the front panel is on the left and right, respectively. Be sure to leave sufficient space on the rear panel so that you can replace power supplies or fan modules, if necessary.

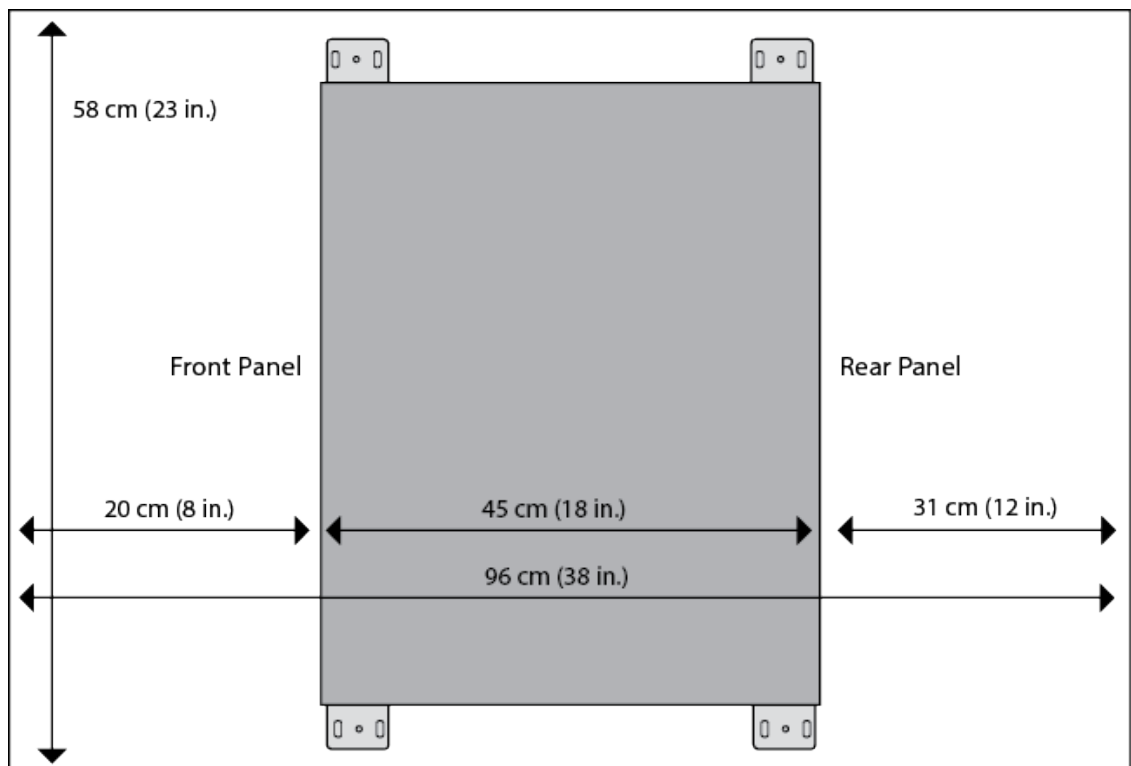


Figure 59. Minimum Wall Area Dimensions with the Front Panel on the Left

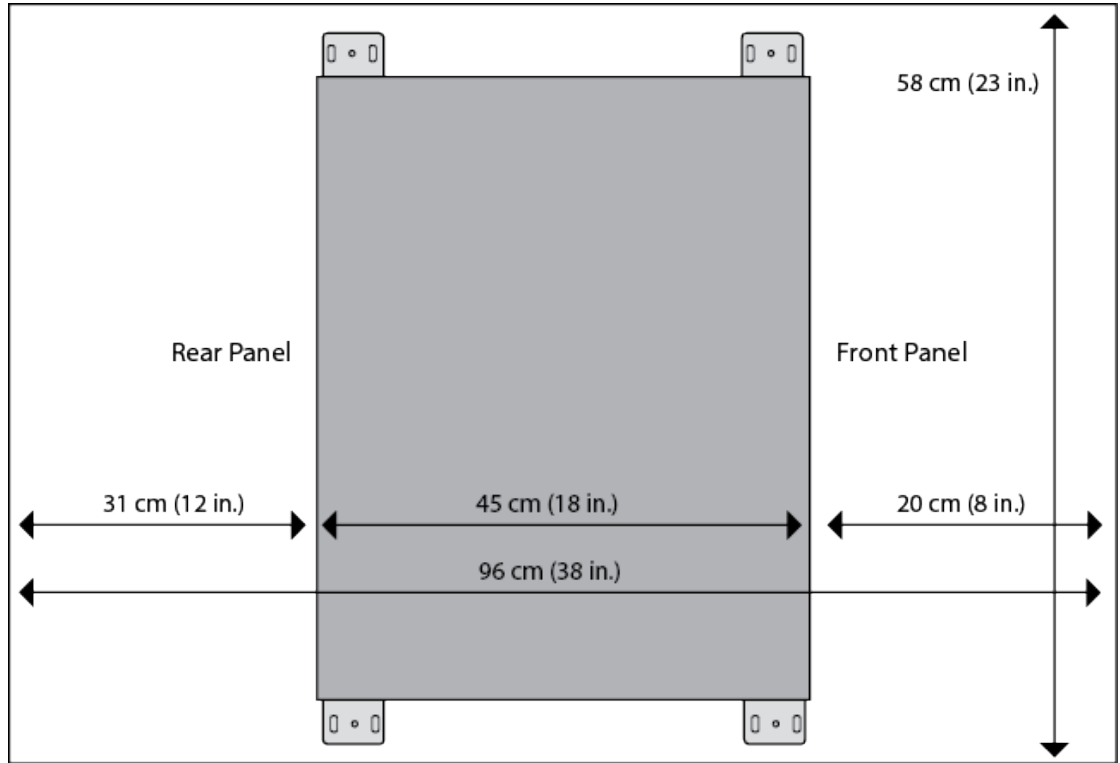


Figure 60. Minimum Wall Area Dimensions with the Front Panel on the Right

Plywood Base for a Wall with Wooden Studs

If you are installing the switch on a wall that has wooden studs, Allied Telesis recommends using a plywood base for the device. (A plywood base is not required for a concrete wall.) Refer to Figure 61.

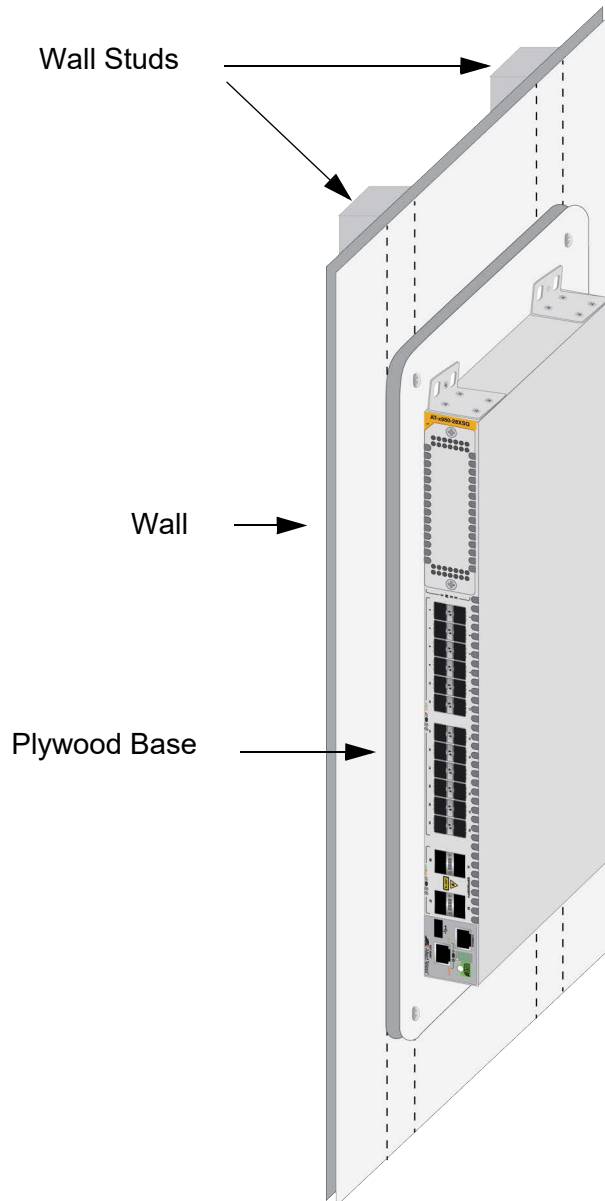


Figure 61. Switch on the Wall with a Plywood Base

The plywood base allows you to mount the switch on two wall studs. Without the base, only one side of the switch would be attached to a stud. This is because the standard distance between two studs in a wall is 41 centimeters (16 inches) while the distance between the left and right brackets on the switch is 37 centimeters (14-1/2 inches).

The recommended minimum dimensions of the plywood base are listed here:

- ❑ Width: 58.4 centimeters (23 inches)
- ❑ Height: 55.9 centimeters (22 inches)
- ❑ Thickness: 5.1 centimeters (2 inches)

The dimensions assume the wall studs are 41 centimeters (16 inches) apart. You may need to adjust the width of the base if the distance between the studs in your wall is different than the industry standard.

You should install the plywood base to the wall and then install the switch on the base. Refer to Figure 62.

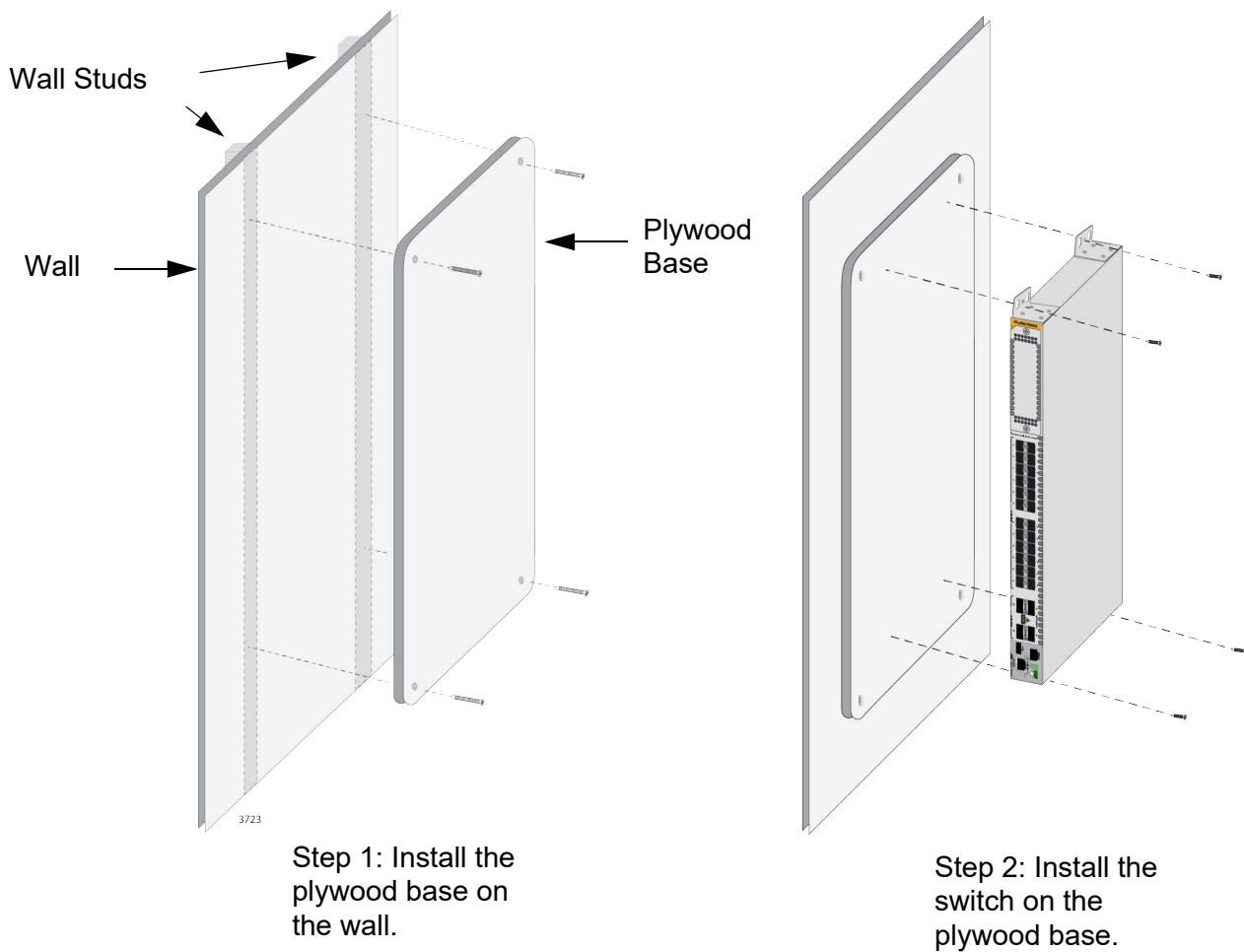


Figure 62. Steps to Installing the Switch with a Plywood Base

Installation Guidelines


Here are the guidelines to installing the switch on a wall:

- ❑ You may install the switch on a wall that has wooden studs.
- ❑ You may install it on a concrete wall.
- ❑ If you are installing the switch on a wall with wooden studs, you should use a plywood base to support the switch. For more information, refer to “Plywood Base for a Wall with Wooden Studs” on page 127. A plywood base is not required for a concrete wall.
- ❑ You should not install the switch on a wall that has metal studs. Metal studs may not be strong enough to safely support the device.
- ❑ You should not install the switch only on sheetrock or similar material. Sheetrock might not be strong enough to safely support the device.
- ❑ You should install the power supplies and XEM2 Line Card before installing the switch on a wall. For instructions, refer to “Installing AT-PWR600 and AT-PWR600R AC Power Supplies” on page 100 and “Installing XEM2 Ethernet Line Cards” on page 106.



Warning


The device is heavy. Always ask for assistance before moving or lifting it to avoid injuring yourself or damaging the equipment.

 E122



Warning

The device should be installed on a wall by a qualified building contractor. Serious injury to yourself or others or damage to the equipment may result if it is not properly fastened to the wall.

 E105

Note

Depending on your installation, it may be easier to install the power supplies and optional XEM2 Line Card before installing the switch on the wall.

Tools and Material

Here are the required tools and material for installing the switch on a wall:

- Four standard brackets and 16 M3x6mm screws (included with the switch) listed in Table 34 on page 93.
- Four wood or concrete wall screws (included with the switch)
- Four concrete wall anchors (included with the switch)
- Cross-head screwdriver (not provided)
- Stud finder for a wooden wall, capable of identifying the middle of wall studs and hot electrical wiring (not provided)
- Drill and 1/4" carbide drill bit for a concrete wall (not provided)
- Plywood base if you are installing the switch on a wall with wooden studs (not provided.) Refer to "Plywood Base for a Wall with Wooden Studs" on page 127 for illustrations.
- Four screws and anchors for attaching the plywood base to the wall (not provided)



Caution

The supplied screws and anchors may not be appropriate for all walls. A qualified building contractor should determine the hardware requirements for your wall before installing the switch. *ES* E88

Installing the Plywood Base

A plywood base is recommended when installing the switch on a wall that has wooden studs. Refer to “Plywood Base for a Wall with Wooden Studs” on page 127. Consult a qualified building contractor for installation instructions for the plywood base. The installation guidelines are listed here:

- ❑ You should use a stud finder to identify the middle of studs and hot electrical wiring in the wall.
- ❑ You should attach the base to two wall studs with a minimum of four screws.
- ❑ The selected wall location for the base should adhere to the recommendations in “Choosing a Site for the Chassis” on page 88 and “Recommended Minimum Wall Area Dimensions” on page 125.

Installing the Switch on the Plywood Base

This procedure assumes that the plywood base for the switch is already installed on the wall. Please review “Reviewing Safety Precautions” on page 82 and “Choosing a Site for the Chassis” on page 88 before performing this procedure. Allied Telesis recommends a minimum of three people for this procedure.



Warning

The device is heavy. Always ask for assistance before moving or lifting it to avoid injuring yourself or damaging the equipment.

Ⓞ E122



Warning

The device should be installed on the wall by a qualified building contractor. Serious injury to yourself or others or damage to the equipment may result if it is not properly fastened to the wall.

Ⓞ E105

Allied Telesis recommends installing the power supplies and XEM2 Line Card before installing the switch on a wall. For instructions, refer to “Installing AT-PWR600 and AT-PWR600R AC Power Supplies” on page 100 and “Installing XEM2 Ethernet Line Cards” on page 106.

To install the switch on the plywood base, perform the following procedure:

1. Place the switch in a table.
2. Install the four brackets with the sixteen screws that come with the switch to the sides of the unit, as shown in Figure 63.



Figure 63. Installing the Brackets to the Switch for Wall Installation

The sides of the switch have two sets of holes. One set is for installing the switch on a wall with the brackets and the other is for the RKMT-SL01 Rack Mounting Kit. For this procedure, you need to use the bracket holes, identified in Figure 52 on page 116.

3. After attaching the brackets to the side of the switch, have two people hold the switch on the plywood base on the wall while you secure it with the four provided screws. Refer to Figure 64.

Please follow these guidelines as you position the switch on the wall:

- ❑ Position the switch so that the front panel is either on the left or the right. Refer to Figure 58 on page 124. You may not install the switch with the front panel facing up or down.
- ❑ Leave sufficient space from other devices or walls so that you can access the front and back panels. Refer to “Recommended Minimum Wall Area Dimensions” on page 125.

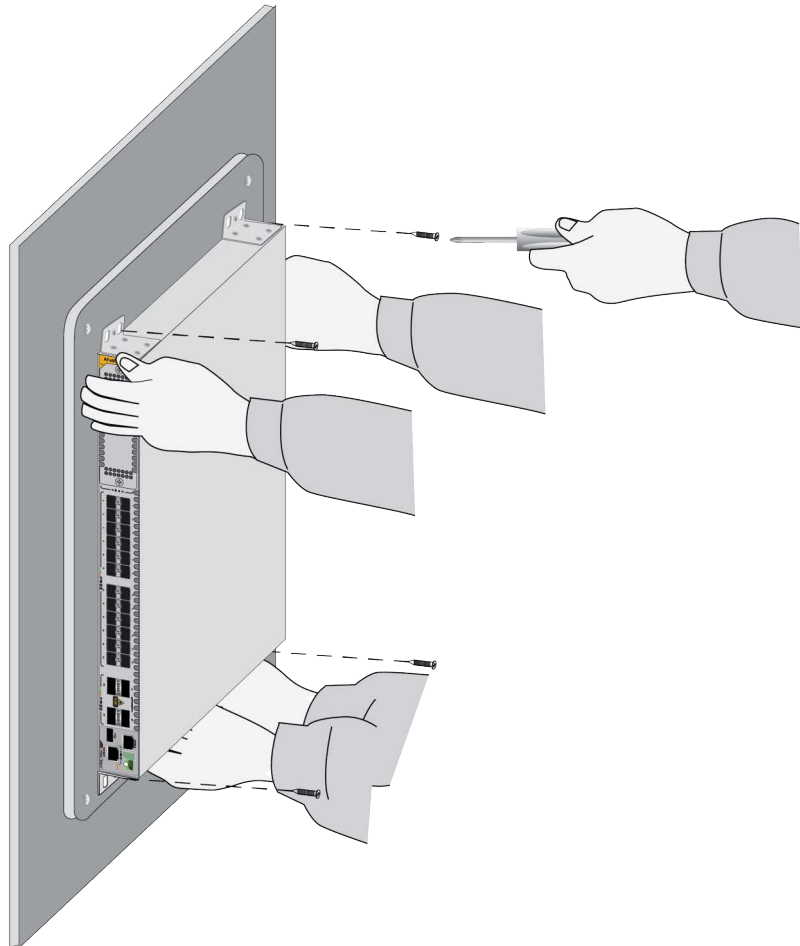


Figure 64. Attaching the Switch to the Plywood Base

4. Do one of the following:
 - ❑ To install the power supplies or Ethernet line card, go to “Installing AT-PWR600 and AT-PWR600R AC Power Supplies” on page 100 and “Installing XEM2 Ethernet Line Cards” on page 106.
 - ❑ If all the components are installed, go to Chapter 9, “Verifying and Configuring the Switch” on page 163.

Installing the Switch on a Concrete Wall

Allied Telesis recommends a minimum of three people for this procedure. To install the switch on a concrete wall, perform the following procedure:



Warning


The device is heavy. Always ask for assistance before moving or lifting it to avoid injuring yourself or damaging the equipment.

 E122



Warning

The device should be installed on a wall by a qualified building contractor. Serious injury to yourself or others or damage to the equipment may result if it is not properly fastened to the wall.

 E105

Allied Telesis recommends installing the power supplies and optional XEM2 Line Card before installing the switch on a wall. For instructions, refer to “Installing AT-PWR600 and AT-PWR600R AC Power Supplies” on page 100 and “Installing XEM2 Ethernet Line Cards” on page 106.

1. Place the switch in a table.
2. Install the four brackets with sixteen screws that come with the switch to the sides of the unit, as shown in Figure 63 on page 132.
3. Have two people hold the switch on the concrete wall at the selected location for the device while you use a pencil or pen to mark the wall with the locations of the four screw holes in the four brackets. Refer to Figure 65 on page 136.

Please follow these guidelines as you position the switch on the wall:

- Position the switch so that the front panel is either on the left or the right. Refer to Figure 58 on page 124. You may not install the switch with the front panel facing up or down.
- Leave sufficient space from other devices or walls so that you can access the front and back panels. Refer to “Recommended Minimum Wall Area Dimensions” on page 125.

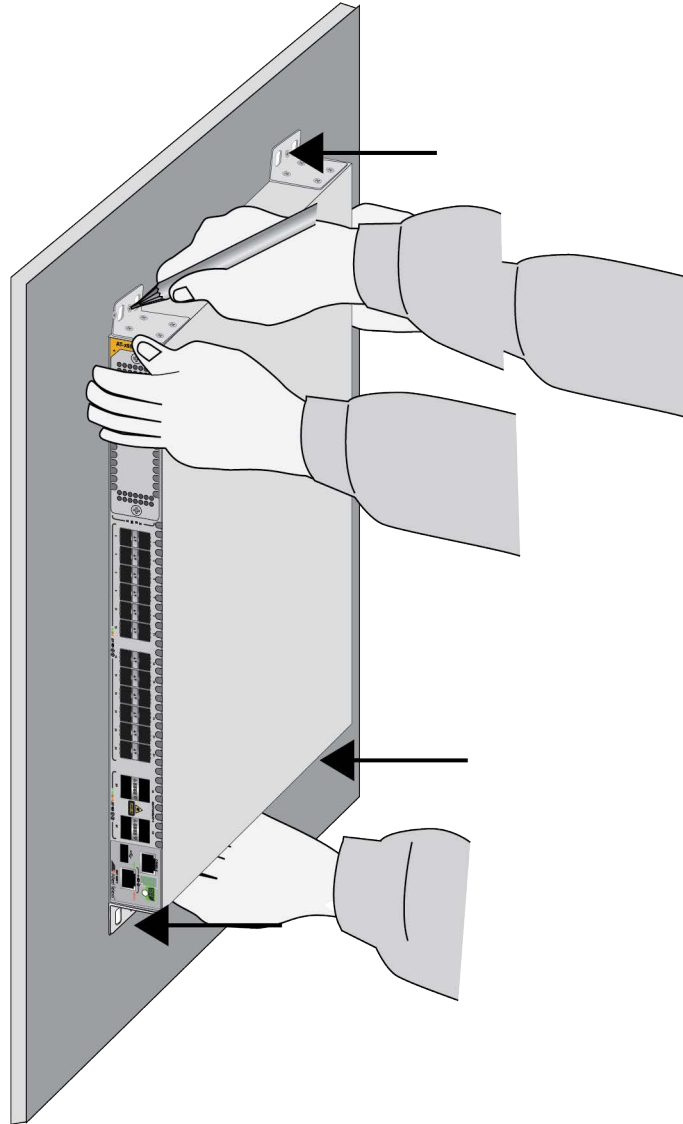


Figure 65. Marking the Locations of the Bracket Holes on a Concrete Wall

4. Place the switch on a table or desk.
5. Use a drill and 1/4" carbide drill bit to pre-drill the four holes you marked in step 3. Please review the following guidelines:
 - ❑ Prior to drilling, set the drill to hammer and rotation mode. The modes break up the concrete and clean out the hole.
 - ❑ Allied Telesis recommends cleaning out the holes with a brush or compressed air.
6. Insert the four anchors into the holes.
7. Have two people hold the switch at the selected wall location while you secure it to the wall with the four provided screws. Refer to Figure 66.

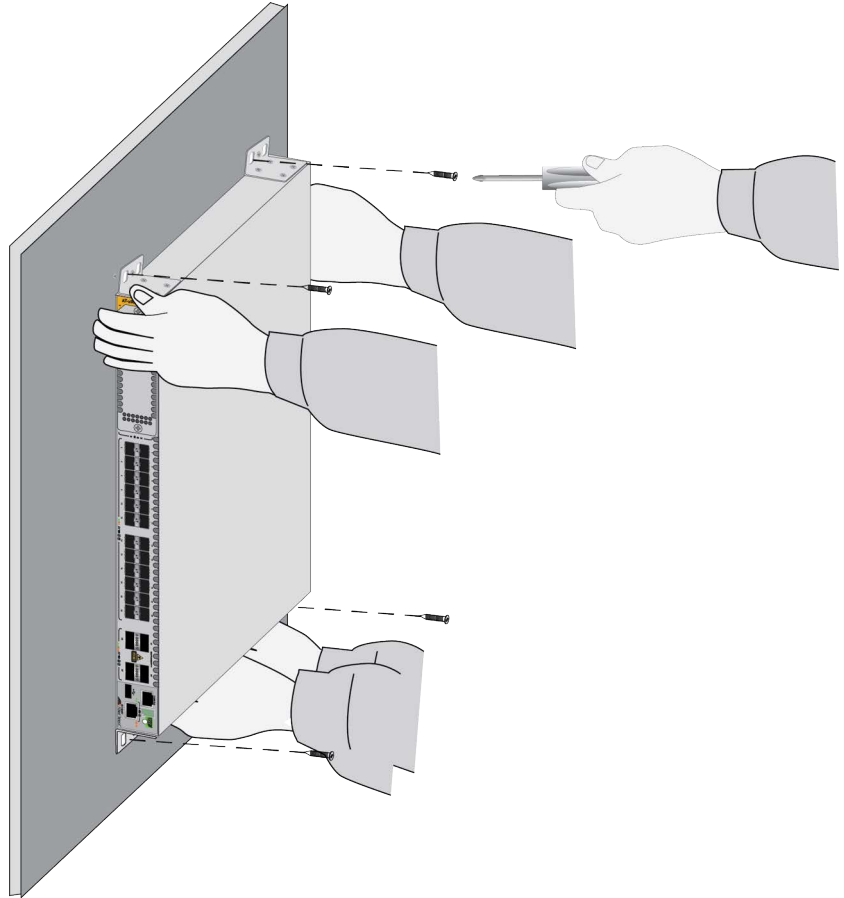


Figure 66. Installing the Switch on a Concrete Wall

8. Do one of the following:
 - To install the power supplies or XEM2 Line Card, go to “Installing AT-PWR600 and AT-PWR600R AC Power Supplies” on page 100 and “Installing XEM2 Ethernet Line Cards” on page 106.
 - If all the components are installed, go to Chapter 9, “Verifying and Configuring the Switch” on page 163.

Chapter 8

Installing the Switch in the AT-RKMT-SL01 Sliding Rack

This chapter contains the following sections:

- “Introduction” on page 140
- “Rack Mount Kit Components” on page 141
- “Equipment Rack Requirements” on page 143
- “Reviewing Safety Precautions” on page 144
- “Installation Overview” on page 146
- “Unpacking the Shipping Container” on page 147
- “Installing the Outer Rails on the Equipment Rack” on page 149
- “Installing the Extension Brackets on the Inner Rails” on page 151
- “Installing the Inner Rails on the Switch” on page 157
- “Installing the Switch in the Equipment Rack” on page 159

Introduction

The AT-RKMT-SL01 Rack Mount Kit is a slide-rail type rack-mount kit for Allied Telesis switches in EIA standard 19-inch equipment racks. The kit makes installation and maintenance of network equipment easier by letting you slide switches into or out of equipment racks, including server racks with deep dimensions.

Note

The AT-RKMT-SL01 Kit should only be used with approved Allied Telesis products.

Rack Mount Kit Components

The kit has three main components.

Adjustable Outer Rails

Two adjustable outer rails attach to the equipment rack. They are suitable for racks with depths of 600 mm (23.6 in) to 900 mm (35.4 in). Refer to Figure 67.

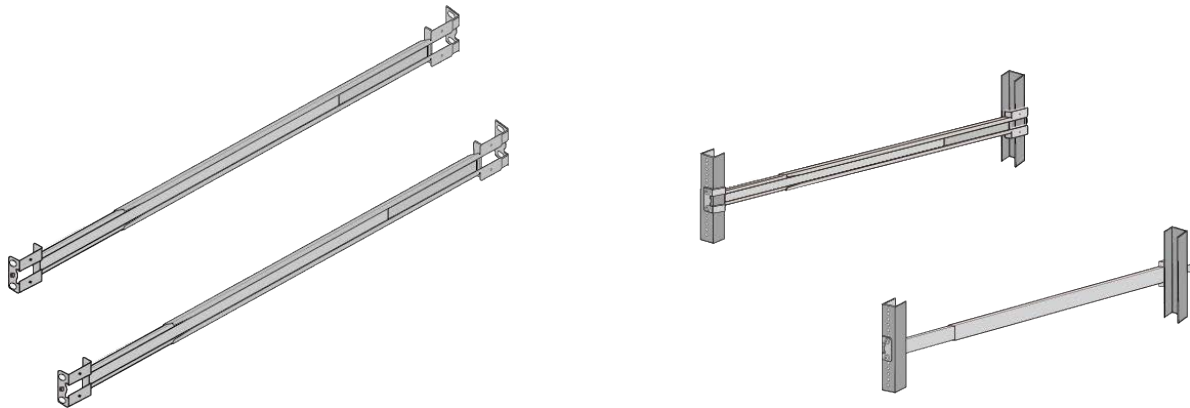


Figure 67. Outer Rails

Inner Rails

Two Inner rails attach to the sides of the switch. Refer to Figure 68.

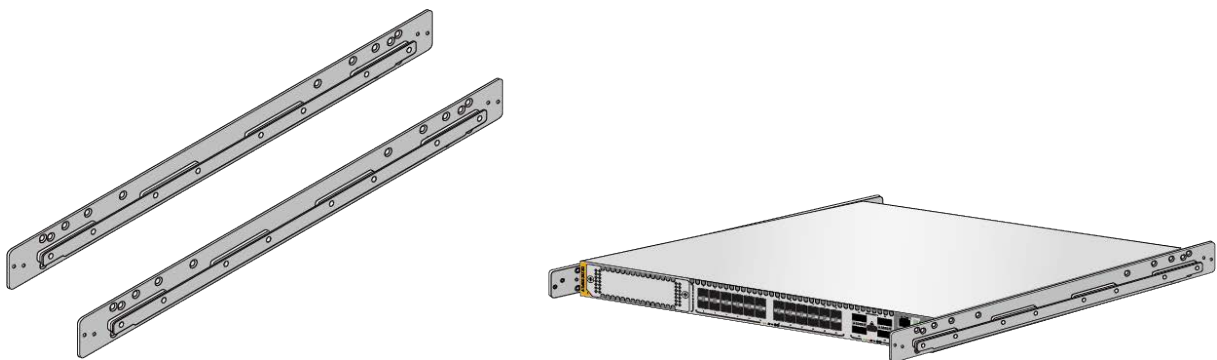


Figure 68. Inner Rails

Extension Brackets

Two extension brackets attach to the front of the inner rails and control the amount the switch is recessed in the equipment rack. The brackets also have a captive screw for securing the switch in the equipment rack. Refer to Figure 69 on page 142.



Figure 69. Extension Brackets

Equipment Rack Requirements


The Rack Mount Kit is designed for equipment racks that meet the following requirements:

- ❑ The depth can be from 600 mm (23.6 in) to 900 mm (35.4 in).
- ❑ The width should be a minimum of 452 mm (17.8 in).
- ❑ There should be 35 mm (1.4 in) depth within the rack post for the outer rail mounting.
- ❑ The distance between the left and right wall (for the outer rail mounting) should be a minimum of 10 mm (0.4 in) from the screw hole in the center of the rack posts.

Reviewing Safety Precautions


Review these safety precautions before installing the AT-RKMT-SL01 Kit.

Note

The  indicates that a translation of the safety statement is available in a PDF document titled **Translated Safety Statements** posted on the Allied Telesis website at www.alliedtelesis.com/support.




Warning

Mounting of the equipment in the rack should be such that a hazardous condition is not created due to uneven mechanical loading.  E25




Warning

Do not pull the rear of the switch out past the front rack posts. If you need to position the rear of the switch out past the front of the rack, you should remove it completely from the rack.  E58




Warning

Pull the switch out slowly if you must remove it from the rack for maintenance. If you pull the switch out past the front of the rack posts, or if you pull it out too quickly, there is a risk that the weight of the switch will cause the sliding rail assemblies to fail and cause the switch to fall out.  E59




Caution

Avoid applying excessive force to the cables.  E60



Caution

If using long extension bracket(s), secure between the fixed bracket and short extension bracket - the long extension bracket(s) cannot be attached directly to the inner rail.  E61

**Caution**

Use the adjustment bracket screws supplied with the inner rail. Using screws other than those supplied may result in equipment damage. ⚡ E62

**Warning**

When installing the outer and inner rails, and adjustment bracket, ensure the components are securely attached with the appropriate screws. If not securely attached, a serious accident may occur due to falling equipment. ⚡ E63

**Warning**

When installing and removing the switch from the rack, disconnect the media and power cables. ⚡ E64

**Warning**

A built-in stopper prevents the outer rail from extending beyond its maximum length of 960 mm (37.8 in). Do not extend the rail by force beyond this point, otherwise, the outer bracket will be weakened, and the switch may fall from the rack; equipment could be damaged. ⚡ E65

**Warning**

Ensure the front and rear of both outer rails are attached at the same distance from the floor, otherwise the switch may fall from the rack. ⚡ E66

**Warning**

Be careful to not drop the switch when lifting and not to pinch your fingers when inserting the switch into the rack. ⚡ E67

**Warning**

Other than maintenance work, secure the switch to the outer rail (via the adjustment bracket): If the switch is not secured properly, there is a risk of the switch falling out during movement caused by an earthquake. ⚡ E68

**Warning**

Do not pull the switch out past the front rack posts. ⚡ E69

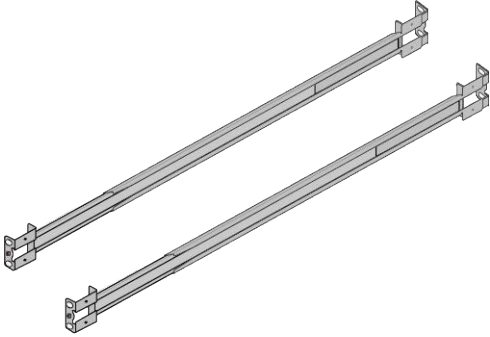
Installation Overview

The following steps summarize the installation procedure for the AT-RKMT-SL01 Rack Mount Kit:

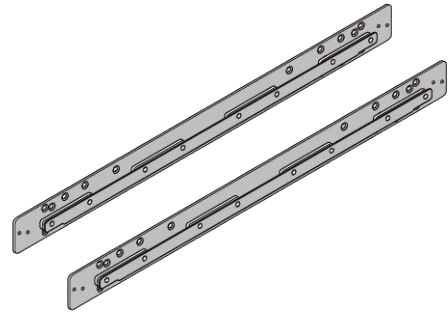
1. Verify the contents of the shipping box. Refer to “Unpacking the Shipping Container” on page 147.
2. Attach the outer rails to the equipment rack. Refer to “Installing the Outer Rails on the Equipment Rack” on page 149.
3. Determine the lengths of the extension brackets and install the brackets on the inner rails. Refer to “Installing the Extension Brackets on the Inner Rails” on page 151.
4. Attach the inner rails to the switch. Refer to “Installing the Inner Rails on the Switch” on page 157.
5. Slide the switch into the outer rails. Refer to “Installing the Switch in the Equipment Rack” on page 159.

Unpacking the Shipping Container

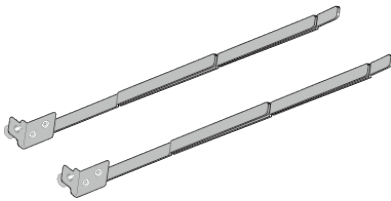
The contents of the shipping container are shown in Figure 70.



Two outer rails - They attach to the equipment rack. Their lengths are adjustable from 600 to 960 mm (23.6 - 37.8 in).



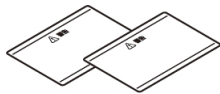
Two inner rails - They attach to the sides of the switch.



Two extension brackets - They set the distance the switch is recessed in the equipment rack and secure the switch to the rack.



- 16 inner rail screws (M4 x 8 countersunk) - They attach the inner rails to the switch. Screw holes and number of screws vary depending on the switch.
- Four extension bracket screws (M3 x 4 countersunk) - They attach the extension brackets to the inner rails.



Two warning labels - They are affixed to the top and bottom of the switch and warn against pulling the switch out past the equipment rack posts.

Figure 70. Shipping Container Contents

Note

Store the packaging material in a safe location. You should use the original shipping material if you need to return the kit to Allied Telesis.



Warning

When installing the outer and inner rails, and extension brackets, ensure the components are securely attached with the appropriate screws. If not securely attached, a serious accident may occur due to falling equipment. ⚡ E63

Installing the Outer Rails on the Equipment Rack

To install the outer rails to the equipment rack, perform the following procedure.

1. Locate the FRONT and REAR labels on the sides of the rails. You have to install the rails with the FRONT labels at the front of the equipment rack and the REAR Labels at the back. Refer to Figure 71.



Figure 71. FRONT and REAR Labels on the Outer Rails

2. Attach the outer rails to the equipment rack using the supplied screws. Use four screws per rail. Refer to Figure 72 on page 150. Installing the switch can be easier if you leave the screws slightly loosened now and fully tightened them after the switch is installed.



Warning

Built-in stoppers prevent the outer rails from extending beyond their maximum length of 960 mm (37.8 in). Do not force the rails beyond the maximum length. Otherwise, the brackets will be weakened, and the switch may fall from the rack and be damaged. ⚡ E65



Warning

Verify that the front and rear of both outer rails are attached at the same distance from the floor, otherwise the switch may fall from the rack. ⚡ E66

3. Go to “Installing the Extension Brackets on the Inner Rails” on page 151.

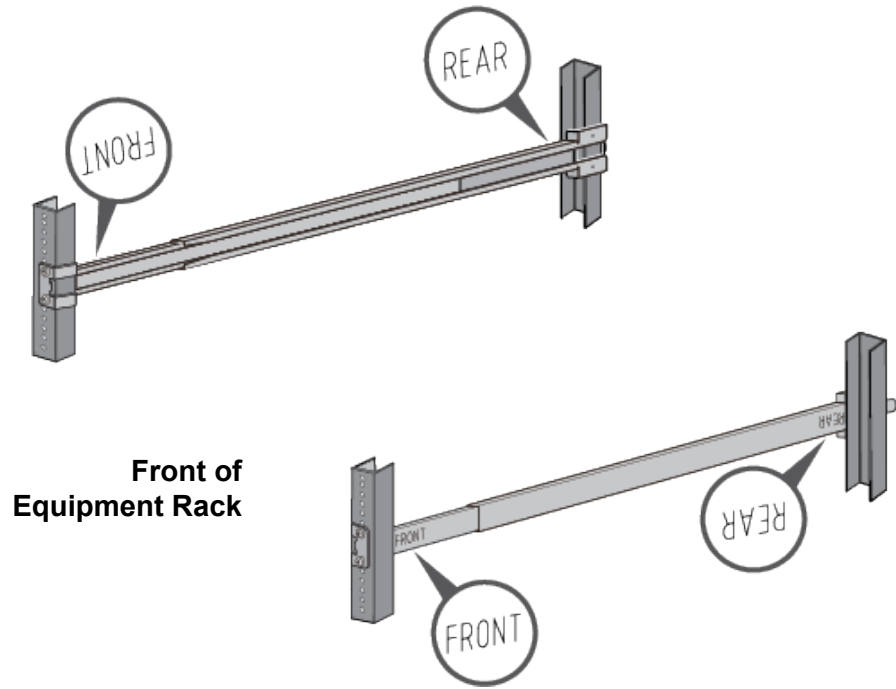


Figure 72. Installing the Outer Rails on the Equipment Rack

Installing the Extension Brackets on the Inner Rails

The kit comes with two extension brackets. Refer to Figure 73.

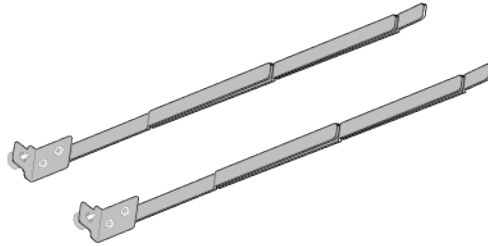


Figure 73. Extension Brackets

You use the brackets to recess the switch in the equipment rack. The maximum distance will depend on the depth of the rack. The deeper the equipment rack, the more the switch can be recessed. The range is approximately 40mm (1.6 in.) to 453mm (17.8 in.). Figure 74 is an example.

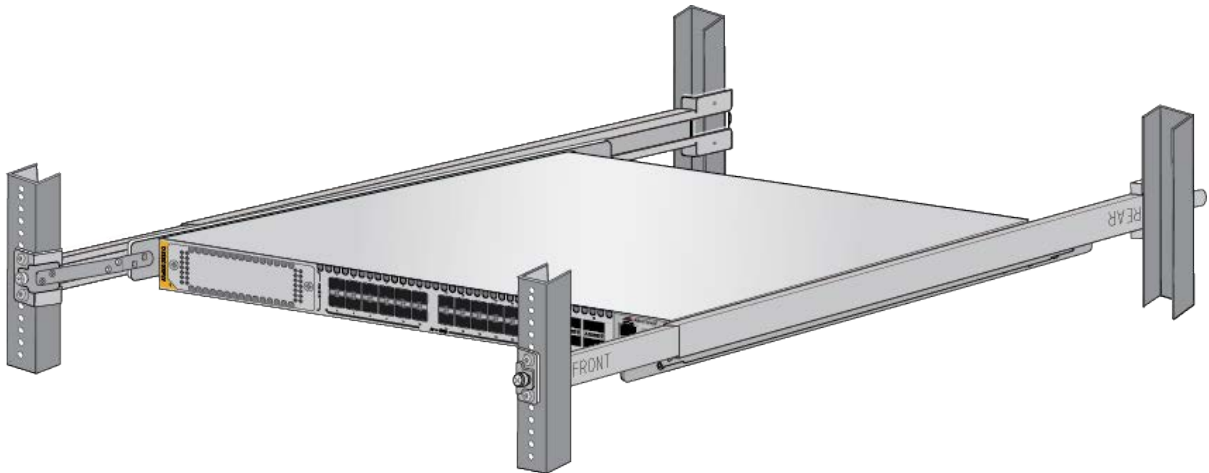


Figure 74. Example of a Switch Recessed in an Equipment Rack

Measuring the Extension Bracket Lengths

The first step is to decide how much you want to recess the front panel of the switch in the rack and then measure the distance. That will tell you the approximate lengths of the extension brackets. Perform the following procedure:

1. Slide one of the inner rails into an outer rail. Be sure that the UP arrow on the inner rail is pointing up. Refer to Figure 75 on page 152.

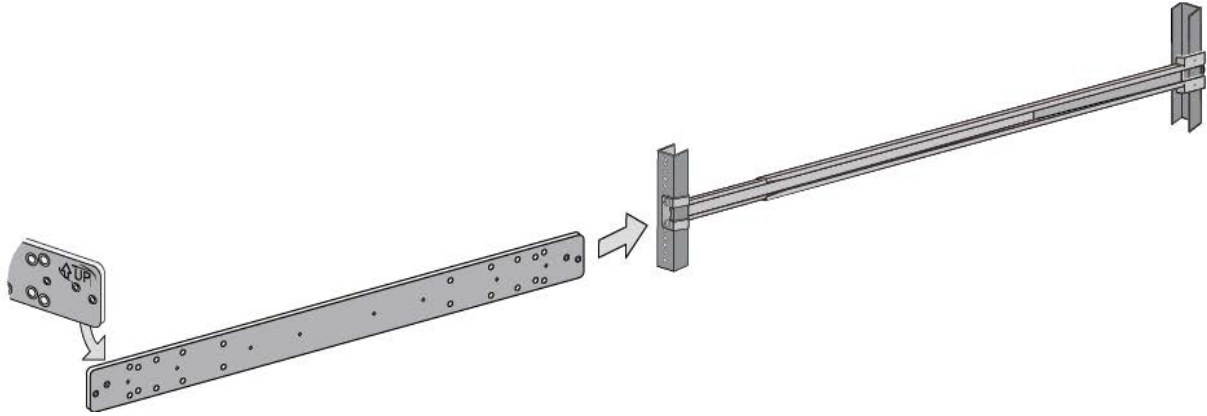


Figure 75. Inserting an Inner Rail into an Outer Rail

2. Position the inner rail at the planned location for the front panel of switch in the sliding rack. Refer to Figure 76.

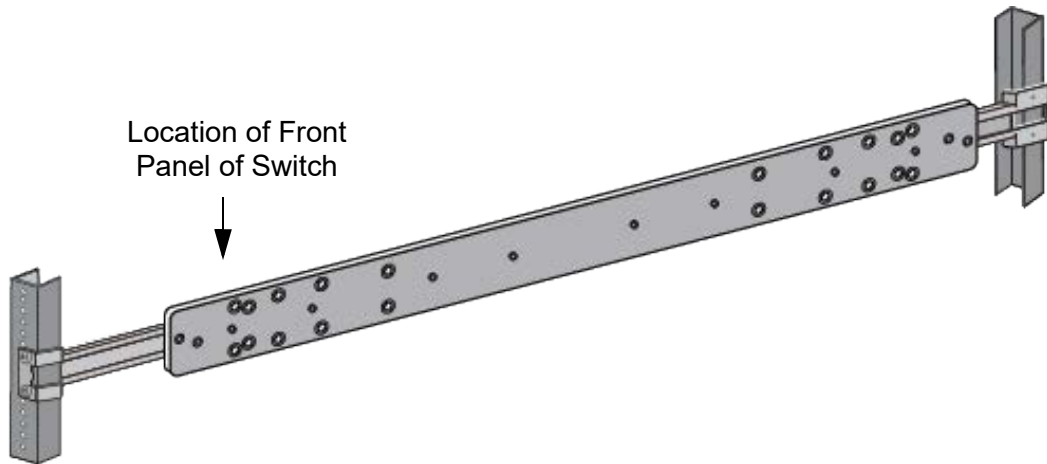


Figure 76. Example of Positioning the Inner Rail

3. Measure the distance from the front of the equipment rack to the front of the inner rail. This will be the approximate length of the extension brackets. Refer to Figure 77.

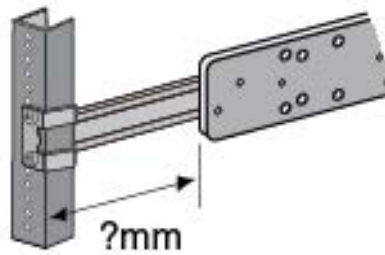


Figure 77. Measuring for the Extension Brackets

- Remove the inner rail from the outer rail. Refer to Figure 78.

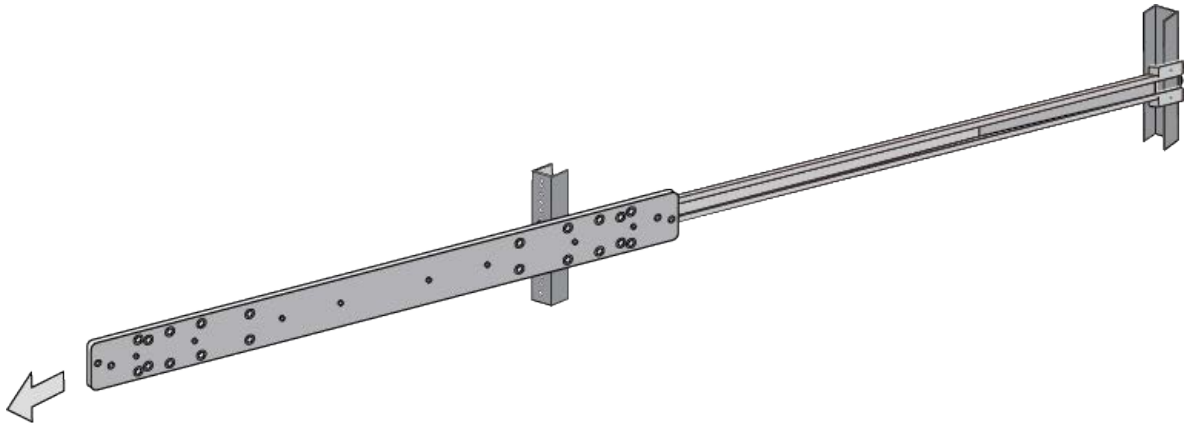


Figure 78. Removing the Inner Rail

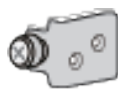
- Go to “Assembling the Extension Brackets,” next.

Assembling the Extension Brackets

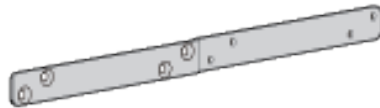
Now that you know the approximate length for the extension brackets, you are ready to assemble them. The brackets consist of four parts. Refer to Table 36 and Figure 79.

Table 36. Extension Bracket Parts

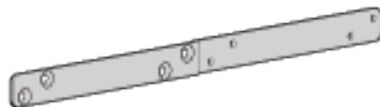
A	Fixed Bracket	1 ea
B	Long Extension Brackets	2 ea
C	Short Extension Bracket	1 ea



A - Fixed Bracket



B - Long Extension Bracket



B - Long Extension Bracket



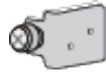
C - Short Extension Bracket

Figure 79. Extension Bracket Parts

You adjust the lengths of the brackets by connecting them in different combinations. There are seven possible configurations. Refer to Figure 80. The default configuration is number 5. To adjust the extension brackets, perform the following procedure:

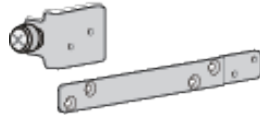
1. Review Figure 80 to find the bracket length that most closely matches the measurement taken in step 3 in the previous procedure.

#1



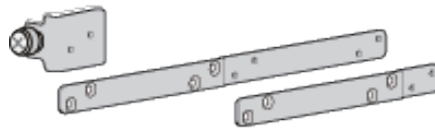
#2

Length:101mm (3.8 in.)



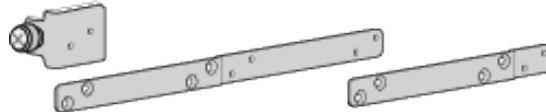
#3

Length:202mm (8.0 in.)



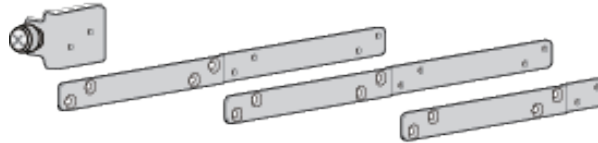
#4

Length:277mm (10.9 in.)



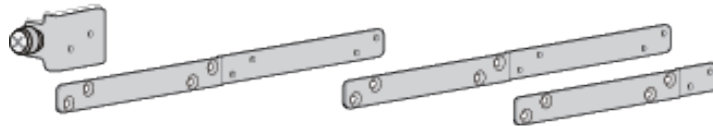
#5

Length:303mm (11.9 in.)
(Factory default)



#6

Length:378mm (14.9 in.)



#7

Length:453mm (17.8 in.)

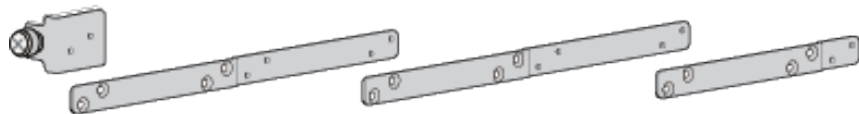


Figure 80. Extension Bracket Configurations

Note

The long brackets have to be used between the fixed and short brackets. You cannot connect them directly to the inner rails.

2. Assemble the extension brackets to match the selected length in the table.
3. Attach the extension brackets to the inner rails. Observe the following:
 - Attach the brackets to the sides of the inner rails with the UP arrows.
 - Attach the screws through the holes on the sides opposite the sides with the UP arrows.

**Caution**

Use the extension bracket screws supplied with the inner rail. Using screws other than those supplied may result in equipment damage.

⚡ E62

Figure 81 shows an example.

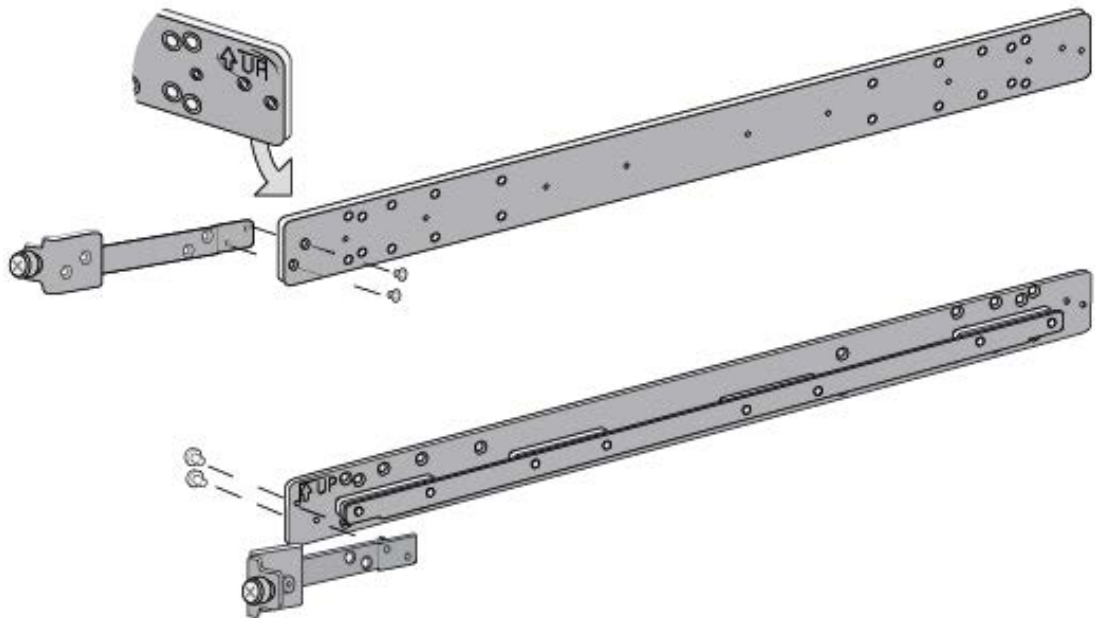


Figure 81. Example of Attaching the Extension Brackets to the Inner Rails

4. To test the lengths of the extension brackets, slide the inner rails into the outer rails in the equipment rack. Refer to Figure 82.

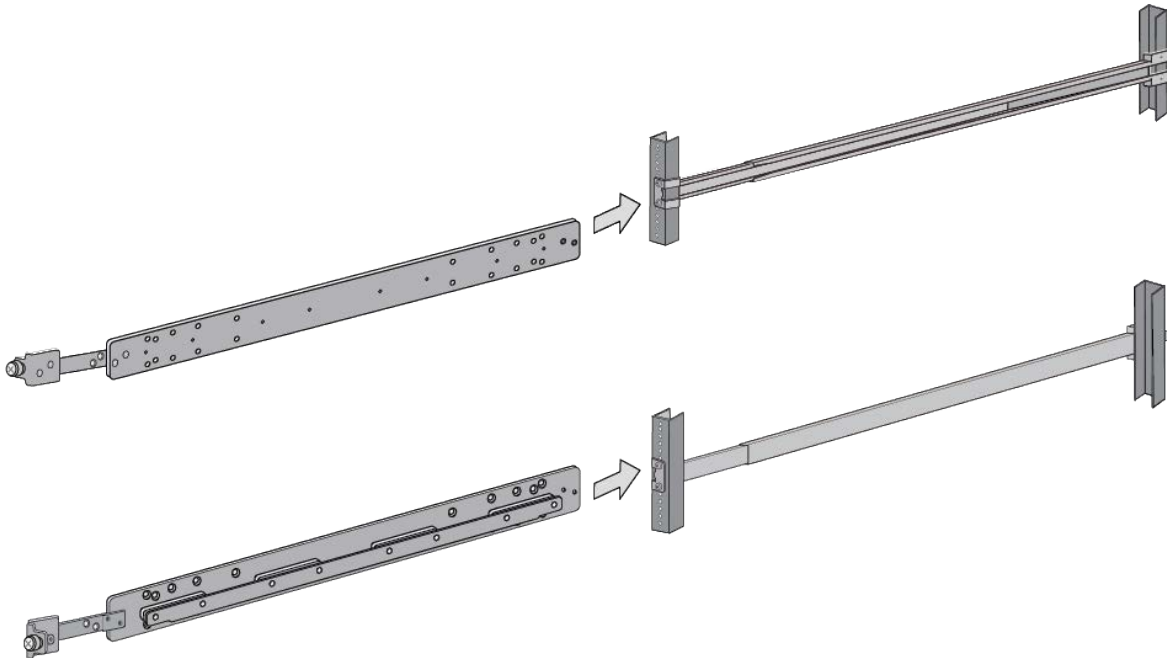


Figure 82. Testing the Inner Rails with the Extension Brackets

5. Measure the distance from the front of the equipment rack to the front of the inner rail. Refer to Figure 83. This should approximately match the value you measured in “Measuring the Extension Bracket Lengths” on page 151.

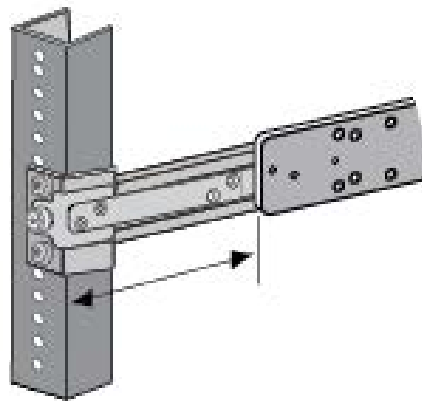


Figure 83. Verifying the Length of the Extension Bracket

6. If the extension brackets are the correct length, remove the inner brackets from the outer brackets and go to “Installing the Inner Rails on the Switch” on page 157.
7. If the brackets are not the correct length, repeat this procedure.

Installing the Inner Rails on the Switch

The sides of the x950 Switches have two sets of bracket screw holes. The smaller M3 holes are for the standard brackets that come with the switch and the larger M4 screw holes are for the inner rails of the AT-RKMT-SL01 sliding rack. The inner rails are attached to the switch with four M4 screws on each side.

Figure 84 identifies the screw holes on the sides of the AT-x950-28XSQ and AT-x950-28XTQm Switches and inner rails.

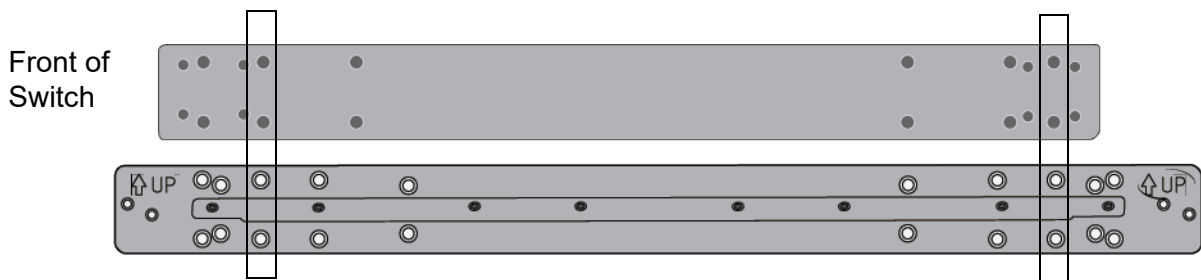


Figure 84. Inner Rail Screw Holes for the AT-x950-28XSQ and AT-x950-28XTQm Switches

Figure 85 identifies the screw holes for the AT-x950-52XSQ and AT-x950-52XTQm Switches and inner rails.

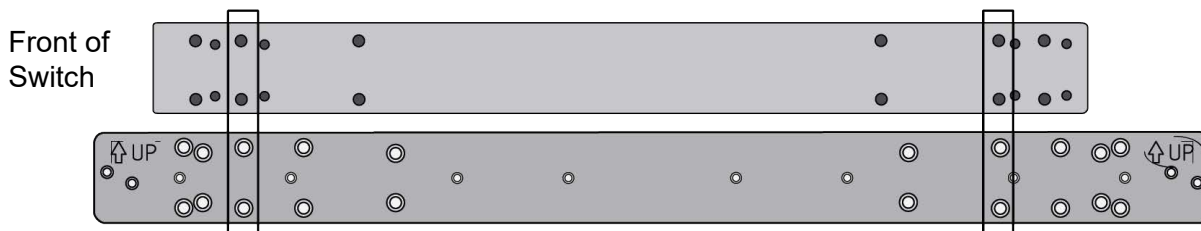


Figure 85. Inner Rail Screw Holes for the AT-x950-52XSQ and AT-x950-52XTQm Switches

Attach the inner rails to the switch using eight M4 screws included with the sliding rack. Be sure that the UP arrows on the rails are pointing up and that the extension brackets extend in front of the switch. Refer to Figure 86 on page 158.

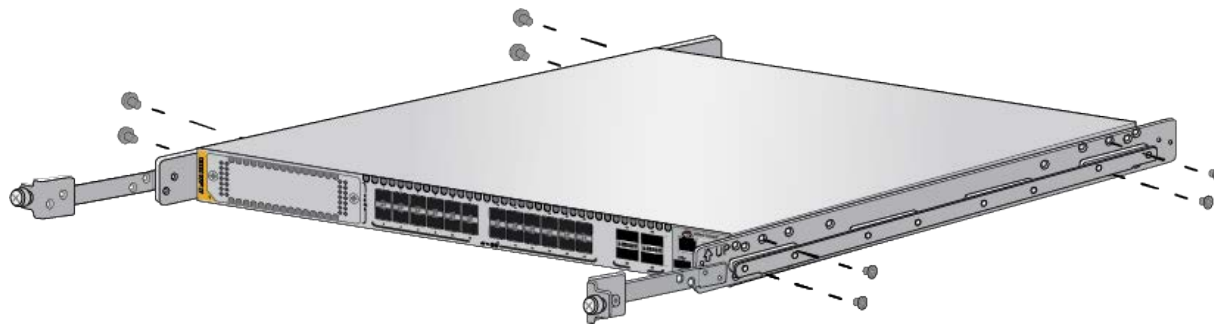


Figure 86. Attaching the Inner Rails to the x950 Switch

Go to “Installing the Switch in the Equipment Rack” on page 159.

Installing the Switch in the Equipment Rack

After attaching the inner rails and extension brackets to the switch, perform the following procedure to install the switch in the sliding rack:



Warning

When installing or removing the switch from the rack, disconnect the media and power cables. ⚡ E64

1. Install the switch in the sliding rack by sliding the inner rails into the outer rail grooves. Refer to Figure 87.

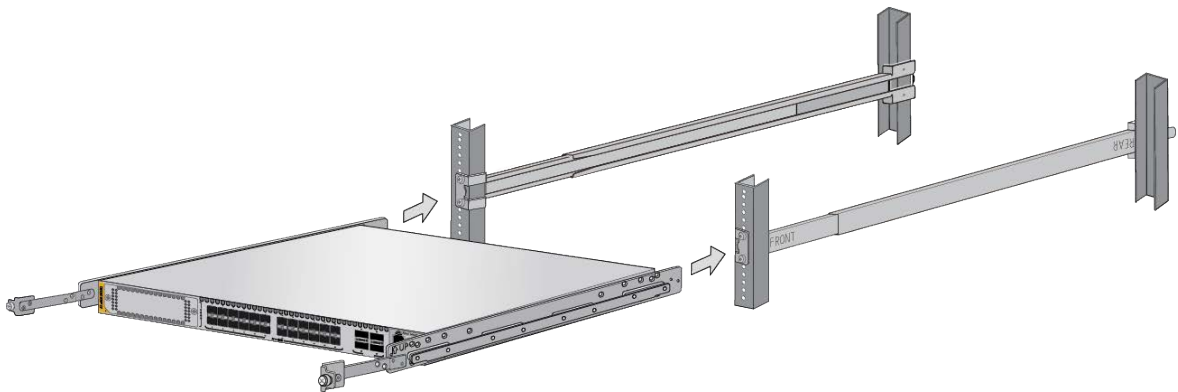


Figure 87. Sliding the Inner Rails on the Switch into the Outer Rails



Warning

Be careful to not drop the switch or pinch your fingers when inserting it into the sliding rack. ⚡ E67

2. Affix the provided warning labels to the top and bottom of the switch, in locations immediately visible when removing the device from the rack. Refer to Figure 88 on page 160.

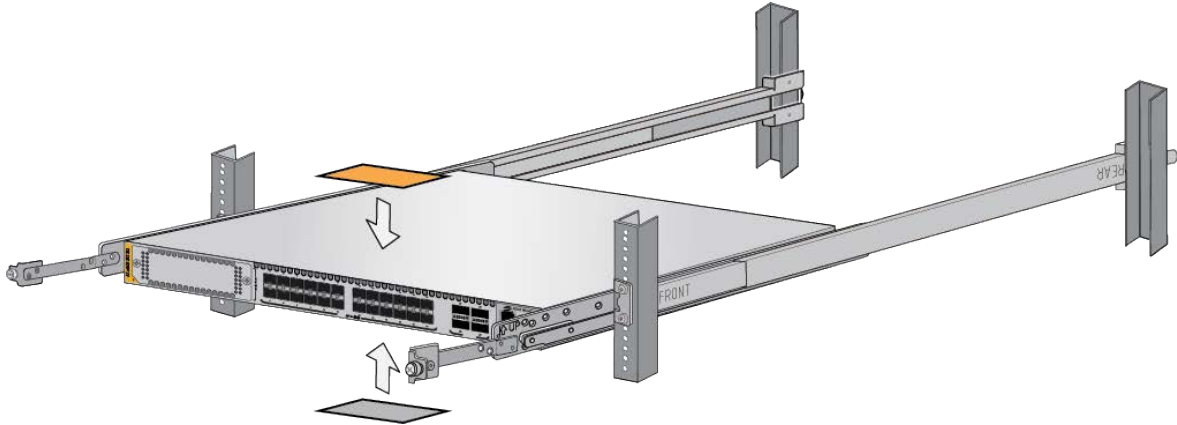


Figure 88. Affixing the Warning Labels

3. Slide the switch fully into the rack.
4. Tighten the two screws on the fixed brackets to secure the switch to the equipment rack. Refer to Figure 89.

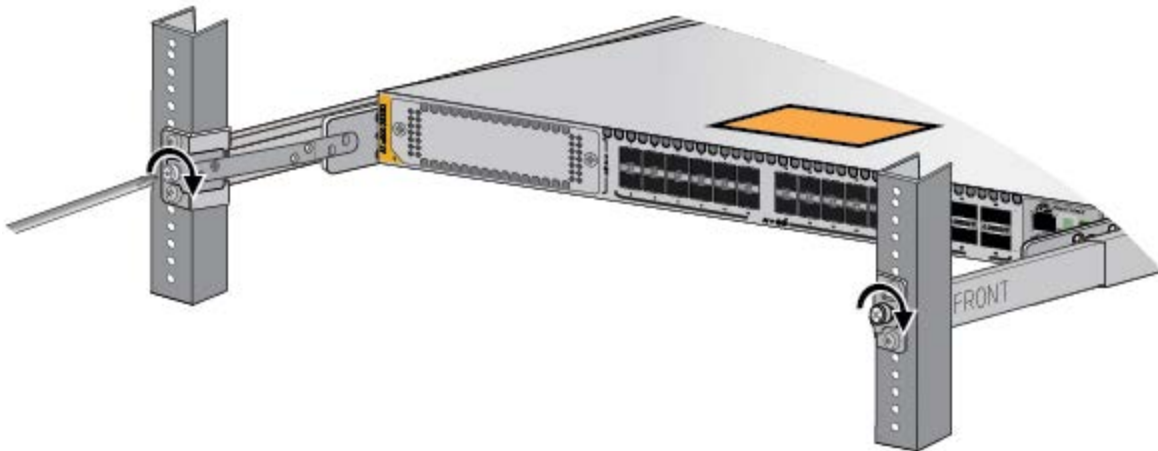


Figure 89. Tightening the Two Screws on the Fixed Brackets



Warning

Always be sure to secure the switch to the outer rail (via the adjustment bracket). If the switch is not secured properly, there is a risk of it falling out during an earthquake. ⚡ E68



Warning

Do not pull the switch out past the front rack posts. ⚡ E69

**Warning**

Pull the switch out slowly if you must remove it from the rack for maintenance. If you pull the switch out past the front of the rack posts, or if you pull it out too quickly, there is a risk that the weight of the switch will cause the sliding rail assemblies to fail and cause the switch to fall out. ⚡ E59

5. Finish tightening the eight screws on the outer rails to secure the rails to the equipment rack. See Figure 90.

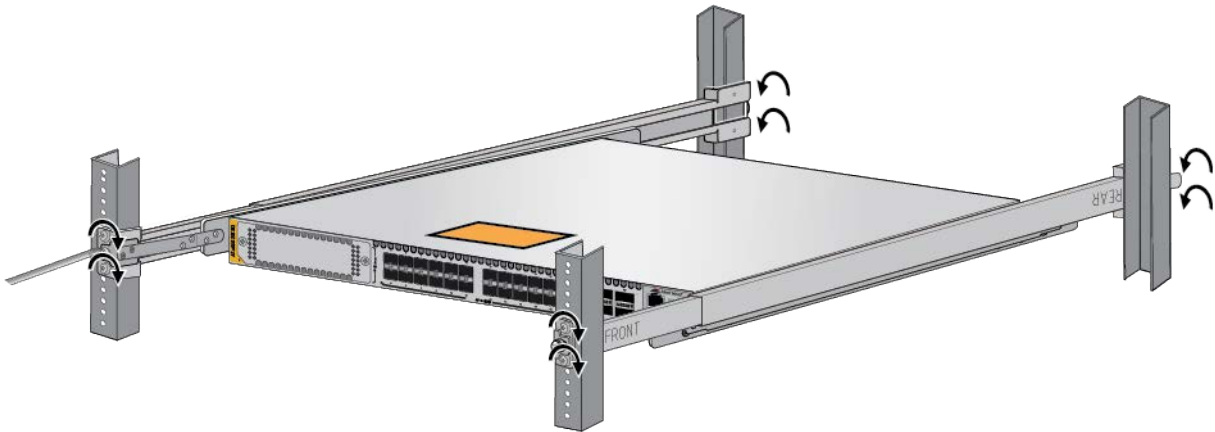


Figure 90. Tightening the Screws on the Outer Rails

This completes the installation procedure. If all the components are installed, go to Chapter 9, “Verifying and Configuring the Switch” on page 163.

Chapter 9

Verifying and Configuring the Switch

This chapter contains the following procedures:

- ❑ “Powering on AT-PWR600 and AT-PWR600R AC Power Supplies” on page 164
- ❑ “Wiring and Powering on AT-PWR600-80 and AT-PWR600R-80 DC Power Supplies” on page 167
- ❑ “Starting a Local Management Session” on page 175
- ❑ “Verifying the Switch with AlliedWare Plus Commands” on page 177
- ❑ “Disabling VCStack” on page 178
- ❑ “Configuring Ports for 40G QSFP+ and 100G QSFP28 Transceivers, and Breakout Cables” on page 181
- ❑ “Saving Your Changes and Rebooting the Switch” on page 183

Powering on AT-PWR600 and AT-PWR600R AC Power Supplies

This section contains the procedure for powering on a switch that has AT-PWR600 or AT-PWR600R Power Supplies. For instructions on installing the power supplies, refer to “Installing AT-PWR600 and AT-PWR600R AC Power Supplies” on page 100.

After powered on, the switch takes several minutes to initialize the AlliedWare Plus operating software. It does not forward network traffic until after it has completed the initialization process. You can monitor the process by connecting a terminal or computer that has a terminal emulator program to the Console port. (The Console port settings are provided in “Starting a Local Management Session” on page 175.)

Note

Before powering on the chassis, review the information in “Power Specifications” on page 229.



Warning

Power cord is used as a disconnection device. To de-energize equipment, disconnect the power cord. ⚡ E3

Note

Pluggable Equipment. The socket outlet shall be installed near the equipment and shall be easily accessible. ⚡ E5

To power on the switch with AT-PWR600 or AT-PWR600R AC Power Supplies, perform the following procedure:

1. Connect the AC power cord included with the power supply to the AC power connector on the rear panel of the chassis. If the chassis has two power supplies, you may power them on one at a time or simultaneously. Refer to Figure 91 on page 165.

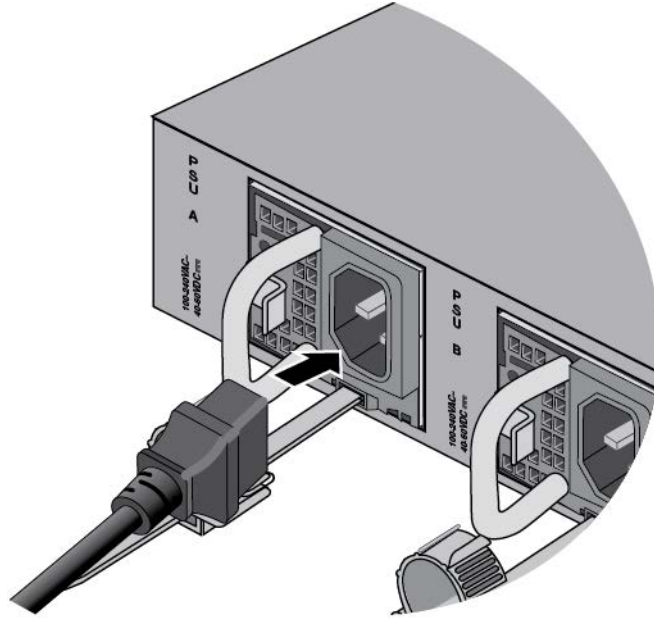
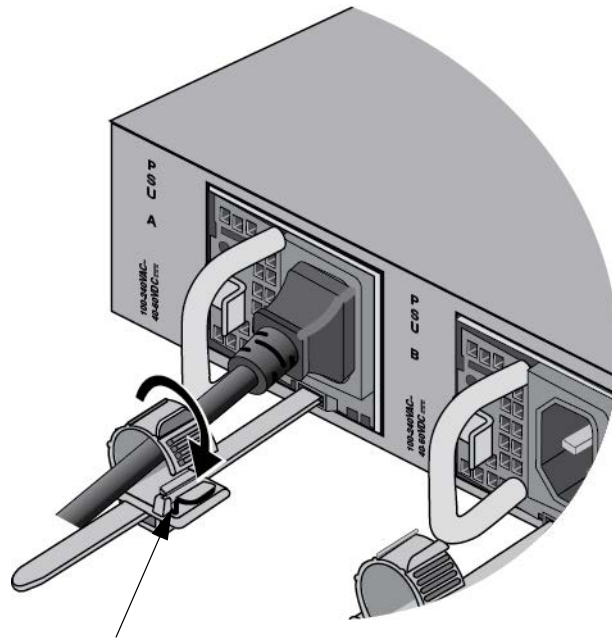


Figure 91. Connecting the AC Power Cord

2. Move the power cord into the restraining strap and secure the strap by feeding it into the tab slot. Refer to Figure 92.



Tab Slot

Figure 92. Securing the Power Cord with the Restraining Strap

3. Connect the power cord to an appropriate AC power source. The AC input voltage characteristic for the AC power supplies is 100 to 240V. Refer to Figure 93.

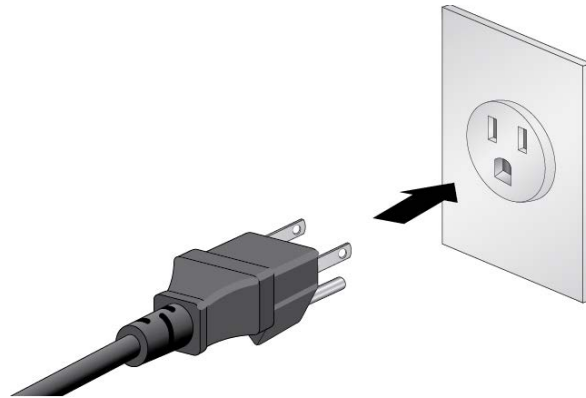


Figure 93. Connecting the Power Cord to an AC Power Source

Note

The illustration shows the North American power cord. Your power cord may be different.

4. If the switch has two AC power supplies, repeat this procedure to connect a power cord to the second power supply.
5. If the switch has a PWR600 DC Power Supply, go to “Wiring and Powering on AT-PWR600-80 and AT-PWR600R-80 DC Power Supplies” on page 167.
6. Wait several minutes for the switch to initialize the AlliedWare Plus management software.
7. Go to “Starting a Local Management Session” on page 175.

Wiring and Powering on AT-PWR600-80 and AT-PWR600R-80 DC Power Supplies

This section contains the procedure for powering on a switch that has AT-PWR600-80 or AT-PWR600R-80 DC Power Supplies. For instructions on installing the power supplies, refer to “Installing AT-PWR600-80 and AT-PWR600R-80 DC Power Supplies” on page 104.

When powered on, the switch takes several minutes to initialize the AlliedWare Plus operating software. It does not forward network traffic until after it has completed the initialization process. You can monitor the process by connecting a terminal or computer that has a terminal emulator program to the Console port. (The Console port settings are provided in “Starting a Local Management Session” on page 175.)

This procedure has the following sections:

- ❑ “Connecting the Grounding Wire,” next
- ❑ “Connecting the DC Power Wires” on page 170
- ❑ “Powering on the DC Power Supplies” on page 174


Connecting the Grounding Wire

Here are the guidelines for the grounding wire:

- ❑ The wire should be minimum #16 AWG solid wire.
- ❑ The wire length should be as short as possible.
- ❑ Continuity from the grounding screw to the earth ground must be less than 0.05 ohms.
- ❑ If a terminal is used, it should be double crimped.




Warning

The equipment must be earthed. The ground screw on the unit must be connected to a properly earthed bonding point.  E120



Warning

When installing this equipment, always ensure that the frame ground connection is installed first and disconnected last.  E11

The material and tools you need for connecting the ground wire:

- ❑ Minimum #16 AWG solid wire
- ❑ Wire insulation stripper
- ❑ Phillips-head screwdriver

To connect the grounding wire with bare wire, perform the following procedure:

1. Strip 2.54cm (1.0 in.) of insulation from the end of the solid grounding wire with a wire insulator stripper. Refer to Figure 94.

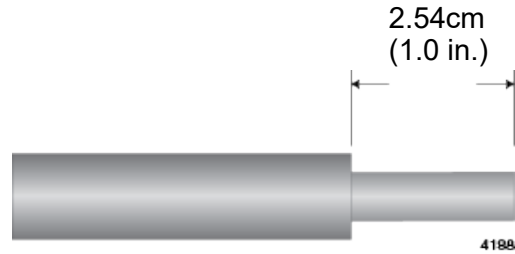


Figure 94. Stripping the Grounding Wire



Warning

Do not strip more than the recommended amount of wire. Stripping more than the recommended amount can create a safety hazard by leaving exposed wire on the terminal block after installation. ⚡ E10

2. Loosen the screw for the connector panel several turns with a Phillips-head screwdriver. Refer to Figure 95.

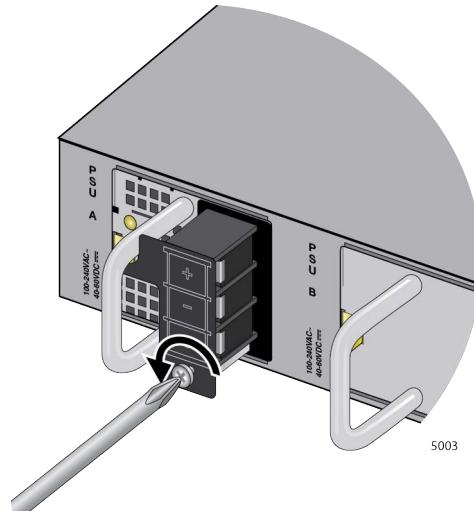


Figure 95. Loosening the Screw for the Panel

3. Pivot the panel to the right to expose the connectors. Refer to Figure 96 on page 169.

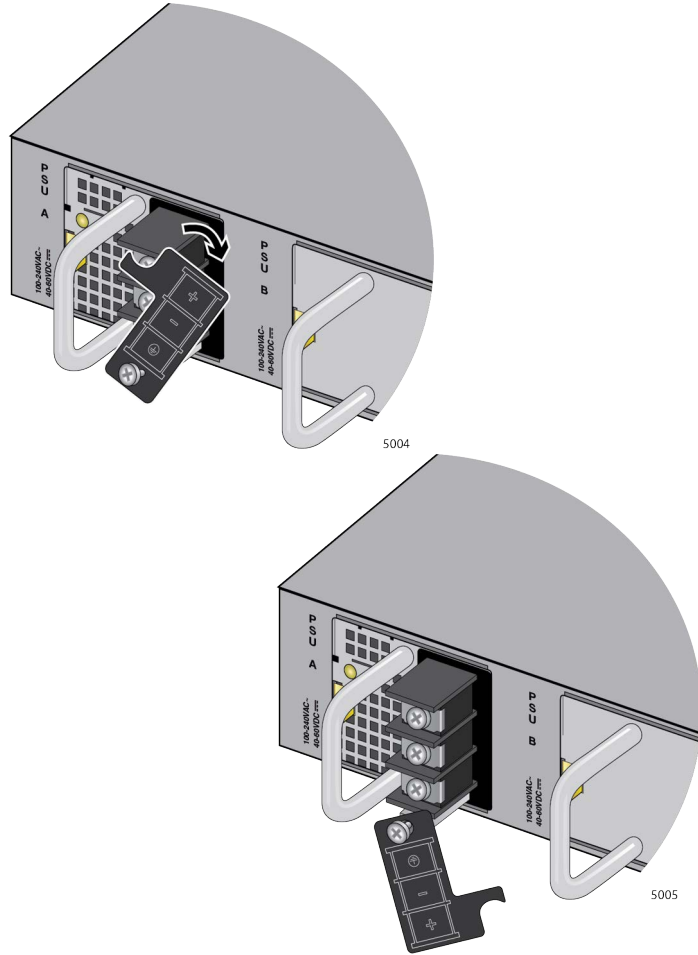


Figure 96. Accessing the Connectors

4. Loosen the ground screw with a Phillips-head screwdriver. Refer to Figure 97.

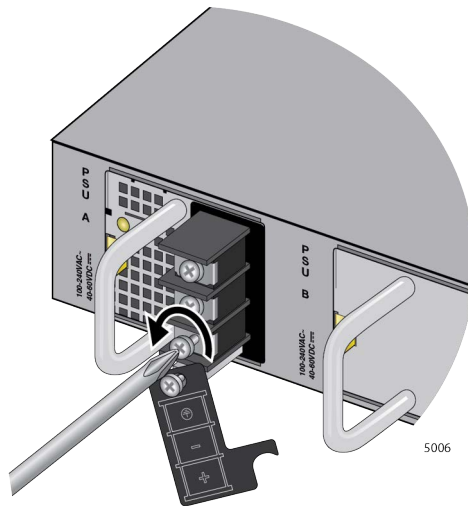


Figure 97. Loosening the Ground Screw

5. Wind the grounding wire clockwise around the base of the grounding screw. Refer to Figure 98.

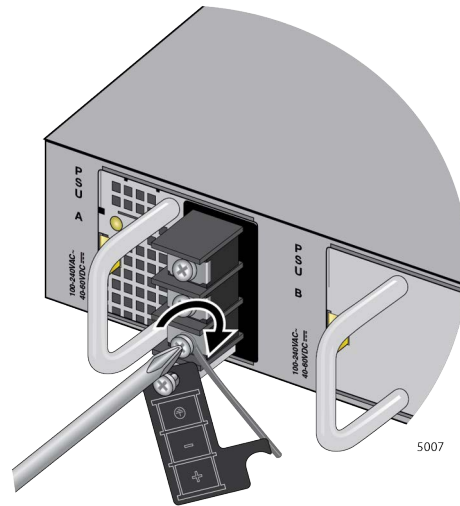


Figure 98. Wrapping the Grounding Wire and Tightening the Screw

6. Tighten the ground screw.
7. Connect the other end of the ground wire to a ground point at the installation site.
8. Go to “Connecting the DC Power Wires,” next.

Connecting the DC Power Wires

Here are the materials and tools for connecting the DC power cables:

- ❑ 18 AWG stranded wires. Do not use wire heavier than 16 AWG solid wire.
- ❑ Wire insulation stripper
- ❑ Phillips-head screwdriver

To connect the DC power cables, perform the following procedure:

1. Strip 6.5mm (0.25 in.) of insulation from the end of the stranded power wires with a wire insulator stripper. Refer to Figure 96.

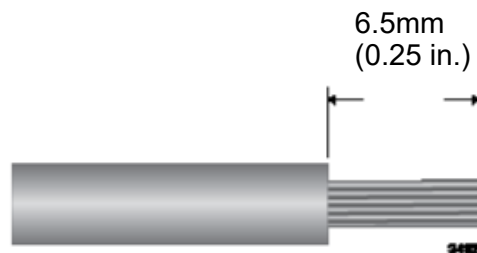


Figure 99. Stripping the Power Wire



Warning

Do not strip more than the recommended amount of wire. Stripping more than the recommended amount can create a safety hazard by leaving exposed wire on the terminal block after installation. *E10*

2. Tightly wrap the wire strands with your finger tips.

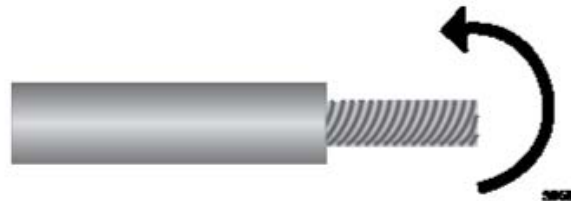


Figure 100. Wrapping the Wire Strands

This step is to prevent loose strands from touching other wires and causing an electrical short.

Note

Allied Telesis recommends tinning the wires with solder for added protection against loose strands. This guide does not provide instructions on how to tin wires.

3. Loosen the middle screw for the negative (-) with a Phillips-head screwdriver. Refer to Figure 101.

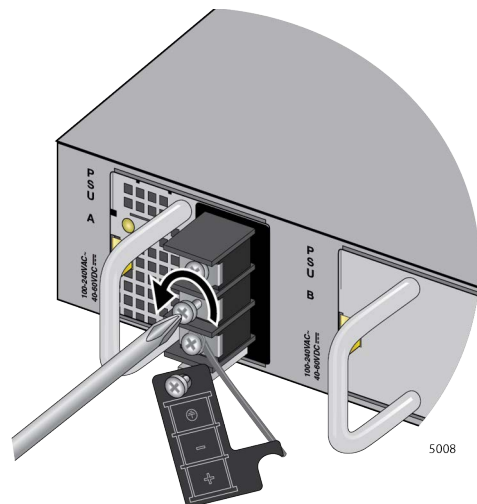


Figure 101. Loosening the Screw for the Negative (-)

4. Wind the power wire and tighten the screw. Refer to Figure 102.

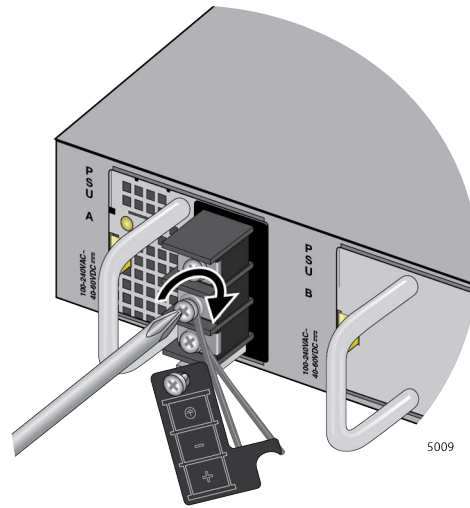


Figure 102. Tightening the Screw for the Negative (-)

5. Loosen the top screw for the positive (+) with a Phillips-head screwdriver. Refer to Figure 103.

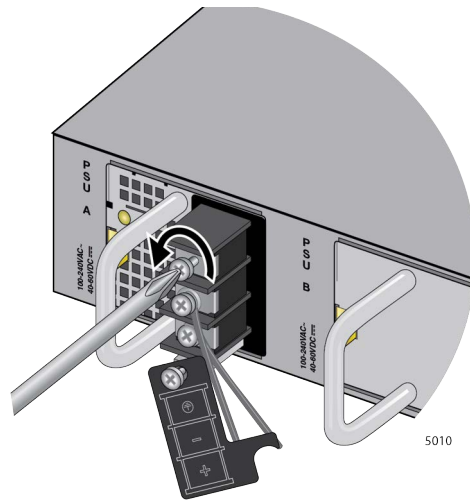


Figure 103. Loosening the Screw for the Positive (+)

6. Wind the power wire and tighten the screw. Refer to Figure 104.

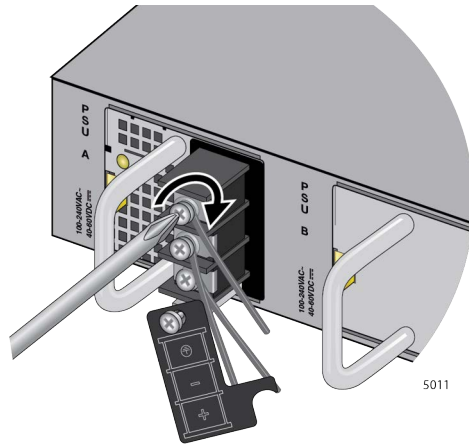


Figure 104. Tightening the Screw for the Negative (+)

7. After attaching the wires to the screws, verify that there are no exposed wires or loose wire strands.



Warning

Check to see if there are any exposed copper strands coming from the installed wires. When this installation is done correctly there should be no exposed copper wire strands extending from the terminal block. Any exposed wiring can conduct harmful levels of electricity to persons touching the wires. ⚡ E12

8. Place the cover panel back to cover the connectors. Refer to Figure 105.

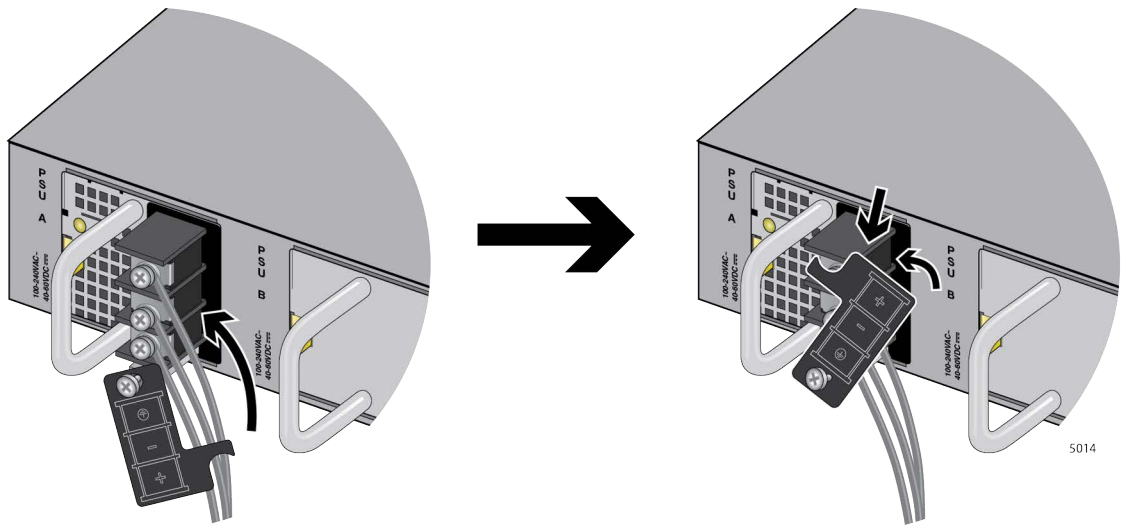


Figure 105. Placing the Cover Panel

9. Tighten the screw for the cover panel. Refer to Figure 106.

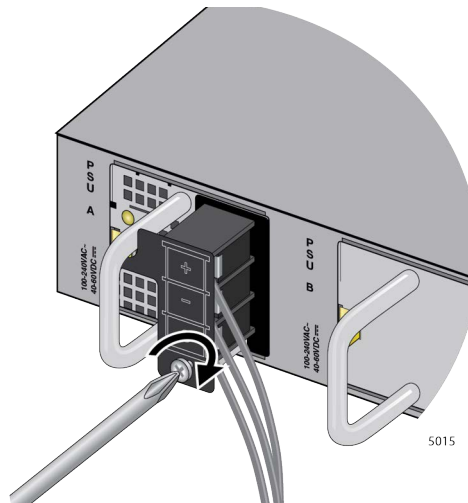


Figure 106. Tightening the Screw for the Cover Panel

10. If the switch has two DC power supplies, repeat the procedures starting with “Connecting the Grounding Wire” on page 167.
11. Go to “Powering on the DC Power Supplies,” next.

Powering on the DC Power Supplies

To power on DC power supplies, perform the following procedure:

1. Verify that the DC power source unit that will provide power to the switch is powered off.
2. Verify that the DC power wires are connected to the PWR600 DC supply.
3. Connect the power wires to the DC power source unit. Refer to the documentation included with the unit for instructions.
4. Power on the DC power source unit.
5. If the switch has two DC power supplies installed, repeat this procedure to power on the second DC power supply.
6. If the switch has a PWR600 AC Power Supply as the second power supply, go to “Powering on AT-PWR600 and AT-PWR600R AC Power Supplies” on page 164.
7. Wait for the switch to initialize the AlliedWare Plus management software. This may take several minutes.
8. Go to “Starting a Local Management Session” on page 175.

Starting a Local Management Session

After powering on the switch and waiting several minutes for it to initialize the AlliedWare Plus management software, start a local management session using the Console port on the management panel, as explained in this section.

Note

The first management session of the switch can be either a local session, as explained in this section, or a remote session over your network through the NET MGMT port. For remote management, the switch uses either its default IP address 192.168.42.42 or an address assigned to it by a DHCP server. For instructions on how to start a remote management session, refer to the *Software Reference for x950 Switches, AlliedWare Plus Operating System*.

To start a local management session, perform the following procedure:

1. Connect the RJ-45 end of the management card included with the switch to the Console RS-232 port on the management panel. Refer to Figure 107.

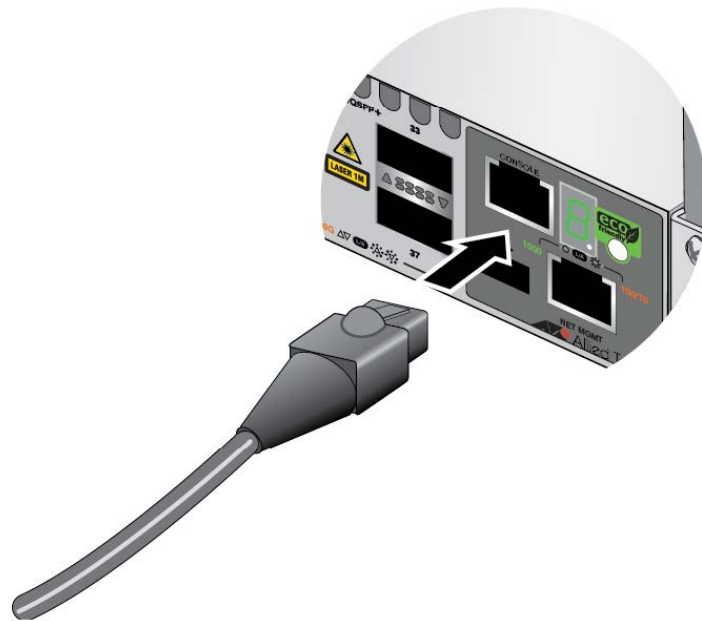


Figure 107. Connecting the Management Cable to the Console RS-232 Port

2. Connect the other end of the cable to an RS-232 port on a terminal or personal computer with a terminal emulation program.

3. Configure the VT-100 terminal or terminal emulation program as follows:
 - Baud rate: 9600 bps
 - Data bits: 8
 - Parity: None
 - Stop bits: 1
 - Flow controller: None

Note


The port settings are for a DEC VT100 or ANSI terminal, or an equivalent terminal emulator program.

4. Press Enter. You are prompted for a user name and password.
5. Enter the default user name and password. They are “manager” and “friend” (without the quotes), respectively

Note

User names and passwords are case sensitive.

The local management session starts when the User Exec mode prompt, shown in Figure 108. is displayed.



```
awplus>
```

Figure 108. User Exec Mode Prompt

Note

The User Exec mode is the first level in the command mode interface. For complete information on the modes and commands, refer to the *Software Reference for x950 Series Switches, AlliedWare Plus Operating System* from www.alliedtelesis.com.

6. Go to “Verifying the Switch with AlliedWare Plus Commands” on page 177.

Verifying the Switch with AlliedWare Plus Commands

Now that the switch is powered on, use the SHOW SYSTEM ENVIRONMENT command in the AlliedWare Plus operating system to verify that the hardware components are operating correctly. To verify the hardware operations, perform the following procedure:

1. Start a local management session on the switch. Refer to “Starting a Local Management Session” on page 175.
2. Enter the SHOW SYSTEM ENVIRONMENT command in the User Exec or Privileged Exec mode.
3. Check the Status column. All components should have the status “OK.”
4. Check the “System Airflow” status. It should display “Front to back” or “Back to front,” depending on the airflows of the fans in the power supplies and fan modules. If the status is “INCOMPATIBLE,” the power supplies and fans have different airflow directions. The switch may overheat and shutdown from inadequate airflow. Review the information in “AT-PWR600 and AT-PWR600R AC and DC Power Supplies” on page 44 and “AT-FAN05 and AT-FAN05R Fan Modules” on page 52. Replace the power supplies and/or fan modules so that their airflow directions are the same.

For information about the command line interface, refer to the *Software Reference for AT-x950 Switches* on the Allied Telesis web site.

5. Go to “Disabling VCStack” on page 178.


Disabling VCStack

The procedure in this section explains how to disable the VCStack feature to use the unit as a standalone switch. You might not have to perform this procedure because the default setting for VCStack is disabled. A simple way to determine whether the VCStack feature is enabled or disabled is by viewing the Switch ID LED:

- ❑ If the LED is displaying “0”, the VCStack feature is already disabled and the switch is operating as a standalone unit. Go to “Configuring Ports for 40G QSFP+ and 100G QSFP28 Transceivers, and Breakout Cables” on page 181.
- ❑ If the LED is displaying the number “1” or higher, the VCStack feature is enabled. You should disable it if you want to use the unit as a standalone switch. For instructions, perform the following procedure.



Caution

You have to reset the switch after disabling the VCStack feature. Some network traffic may be lost if the device is connected to a live network.  E89

If the switch is powered off, start with step 1. Otherwise, start with step 3:

1. Power on the switch by referring to “Powering on AT-PWR600 and AT-PWR600R AC Power Supplies” on page 164 or “Wiring and Powering on AT-PWR600-80 and AT-PWR600R-80 DC Power Supplies” on page 167.
2. Wait several minutes for the switch to initialize the AlliedWare Plus management software.
3. Start a local management session on the device. Refer to “Starting a Local Management Session” on page 175.
4. Enter the SHOW STACK command in the User Exec mode prompt to display the status of the VCStack feature. An example is shown in Figure 109.

```
awplus> show stack
Virtual Chassis Stacking summary information
ID      Pending ID  MAC address      Priority  Status  Role
1       -             eccd:6dd1:64a2  128     Ready   Active Master
Operational Status           Stacking Hardware Disabled
Stack MAC address            eccd:6dd1:64a2
awplus>
```

Figure 109. SHOW STACK Command

5. Review the following items:
 - ❑ If the Operational Status is “Stacking Hardware Disabled,” the VCStack feature is already disabled on the switch. Go to “Configuring Ports for 40G QSFP+ and 100G QSFP28 Transceivers, and Breakout Cables” on page 181.
 - ❑ If the Operational Status is “Standalone Unit,” the VCStack feature is enabled on the unit. You must disable it by performing the steps in the rest of this procedure, to use the chassis as a stand-alone switch. (The status says “standalone” because the device is functioning as a stack of one switch.)
6. Enter the ENABLE and CONFIGURE TERMINAL commands to move to the Global Configuration mode. Refer to Figure 110.

```
awplus> enable
awplus# configure terminal
Enter configuration commands, one per line. End with CNTL/Z
awplus(config)#
```

Figure 110. Moving to the Global Configuration Mode

7. To disable the VCStack feature, enter the NO STACK ENABLE command in this format:

```
no stack id enable
```

The ID parameter is the ID number of the switch, displayed on the ID LED. Replace the parameter with whatever number is on the ID LED. For example, if the Switch ID LED number is 1, you would enter the command as follows:

```
awplus(config)# no stack 1 enable
```

This confirmation prompt in Figure 111 is displayed.

```
Warning; This will disable the stacking hardware on member-1.
Are you sure you want to continue? (y/n):
```

Figure 111. Confirmation Prompt for the NO STACK ENABLE Command

8. Type Y to disable VCStack on the switch.
9. Enter the EXIT command to return to the Privileged Exec mode. Refer to Figure 112.

```
awplus(config)# exit
awplus#
```

Figure 112. Returning to the Privileged Exec Mode

10. Enter the WRITE command to save your change in the configuration file. The switch displays the confirmation prompt in Figure 113.

```
awplus# write
Building configuration ...
[OK]
awplus#
```

Figure 113. Saving the Changes with the WRITE Command

If this is the first management session, the switch automatically creates the Default.cfg file in flash memory to store your changes.

11. Enter the REBOOT command to reboot the switch.
12. At the confirmation prompt, type “Y” for yes.
13. Wait several minutes for the switch to initialize the AlliedWare Plus management software.
14. Examine the Switch ID LED. The switch is ready for normal network operations as a standalone unit if its ID number is “0.” If the number is “1 or higher,” repeat this procedure, being sure to save the configuration change with the WRITE command in step 10.
15. Go to “Configuring Ports for 40G QSFP+ and 100G QSFP28 Transceivers, and Breakout Cables” on page 181.

Configuring Ports for 40G QSFP+ and 100G QSFP28 Transceivers, and Breakout Cables

The procedure in this section applies to the following ports:

- ❑ Ports 25, 29, 33, and 37 on AT-x950-28XSQ and AT-x950-28XTQm Switches
- ❑ Ports 49, 53, 57, and 61 on AT-x950-52XSQ and AT-x950-52XTQm Switches
- ❑ Ports 1, 5, 9, and 13 on the XEM2-4QS Line Card

The procedure explains how to configure the ports for the following devices:

- ❑ 40G QSFP+ transceivers
- ❑ 100G QSFP28 transceivers
- ❑ 40G to 10G copper and fiber optic breakout cables

You have to configure the ports for the transceivers with the PLATFORM PORTMODE INTERFACE command in the Global Configuration mode. The default setting for the ports is 40G QSFP+ transceivers. You can skip this procedure if you will be using only 40G QSFP+ transceivers in the ports.

Note

You have to reset the switch after configuring ports for 100G transceivers or after replacing 100G transceivers with 40G transceivers or breakout cables.

To configure the ports, perform the following procedure:

1. Start a local management session. For instructions, refer to “Starting a Local Management Session” on page 175.
2. Move to the Global Configuration mode by entering the ENABLE and CONFIGURE TERMINAL commands. Refer to Figure 110 on page 179.
3. Enter the PLATFORM PORTMODE INTERFACE command to configure the ports. The format of the command is shown here:

```
platform portmode interface ports 10gx4|40g|100g
```

The variables are defined here:

- ❑ The PORTS variable specifies the ports to be configured. Refer to “Designating Ports in the Command Line Interface” on page 54 for information.
- ❑ The 10gx4 parameter configures ports for breakout cables.
- ❑ The 40g parameter configures ports for 40G QSFP+ transceivers. This is the default setting.
- ❑ The 100g parameter configures ports for 100G QSFP28 transceivers.

This example configures ports 33 and 37 on the AT-x950-28XSQ and AT-x950-28XTQm Switches for 100G QSFP28 transceivers:

```
awplus(config)# platform portmode interface  
port1.0.33, port1.0.37 100g
```

This example configures ports 61 on the AT-x950-52XSQ and AT-x950-52XTQm Switches for 100G QSFP28 transceivers:

```
awplus(config)# platform portmode interface  
port1.0.61 100g
```

This example configures port 5 on the XEM2-4QS Line Card for a breakout cable:

```
awplus(config)# platform portmode interface  
port1.1.5 10gx4
```

4. After configuring the ports, go to “Saving Your Changes and Rebooting the Switch” on page 183.

Saving Your Changes and Rebooting the Switch

After disabling the VCStack feature or configuring ports 25, 29, 33, and 37 or ports 49, 53, 57, and 61, you have to save your configuration changes and reboot the switch, as explained in the following procedure:

1. From the Global Configuration mode, enter the EXIT command to return to the Privileged Exec mode, as shown in Figure 112.

```
awplus(config)# exit
awplus#
```

Figure 114. Returning to the Privileged Exec Mode with the EXIT Command

2. Enter the WRITE command to save your change in the configuration file. Refer to Figure 113.

```
awplus# write
Building configuration ...
[OK]
awplus#
```

Figure 115. Saving Changes with the WRITE Command

If this is the first management session, the switch automatically creates a Default.cfg configuration file in flash memory to store your changes.

3. Enter the REBOOT command to reboot the switch.
4. At the confirmation prompt, type “Y” for yes.
5. Wait several minutes for the switch to complete initializing the AlliedWare Plus management software.
6. Examine the Switch ID LED again. The switch is ready for normal network operations as a standalone unit when its ID number is “0.” If the number is not “0,” repeat “Disabling VCStack” on page 178. Be sure to save your configuration changes with the WRITE command.
7. Go to Chapter 10, “Cabling the Networking Ports” on page 185.

Chapter 10

Cabling the Networking Ports

This chapter contains the following procedures:

- ❑ “Cabling Copper Ports” on page 186
- ❑ “Guidelines to Handling Copper and Fiber Optic Transceivers” on page 187
- ❑ “Installing Transceivers” on page 188
- ❑ “Installing Direct Attach Cables” on page 194

Cabling Copper Ports

This section applies to the copper ports on the following products:

- ❑ AT-x950-28XTQm Switch
- ❑ AT-x950-52XTQm Switch
- ❑ AT-XEM2-8XSTm Line Card
- ❑ AT-XEM2-12XT Line Card
- ❑ AT-XEM2-12XTm Line Card

Here are the cabling guidelines:

- ❑ Minimum cable requirements are:
 - 100M - Standard TIA/EIA 568-B-compliant Category 3 unshielded cabling.
 - 1/2.5/5G - Standard TIA/EIA 568-A-compliant Category 5 or TIA/EIA 568-B-compliant Enhanced Category 5 (Cat 5e) unshielded cabling.
 - 10G -Standard TIA/EIA 568-C-compliant Category 6a unshielded cabling.
- ❑ The connectors on the cables should fit snugly into the ports, and the tabs should lock the connectors into place.
- ❑ The default speed setting for the ports is Auto-Negotiation. This setting is appropriate for ports connected to network devices that also support Auto-Negotiation.
- ❑ The ports must be set to Auto-Negotiation, the default setting, to operate at 1G, 2.5G, 5G, or 10G.
- ❑ The ports support full-duplex only.
- ❑ Do not attach cables to ports of static or LACP port trunks until you have configure the trunks on the switch. Otherwise, the ports will form network loops that can adversely affect network performance.

Guidelines to Handling Copper and Fiber Optic Transceivers

Please review the following guidelines before installing copper and fiber optic transceivers:

- ❑ Transceivers are hot-swappable. You can install them while the switch is powered on.
- ❑ For a list of supported transceivers, refer to the product data sheet on the Allied Telesis web site.
- ❑ The operational specifications and fiber optic cable requirements are provided in the documents included with the transceivers.
- ❑ You should install transceivers in XEM2 Line Cards before connecting their fiber optic cables.
- ❑ Fiber optic transceivers are dust sensitive. Always keep the plug in the optical bores when a fiber optic cable is not installed, or when you store the transceiver. When you do remove the plug, keep it for future use.
- ❑ Repetitive removal or insertion of transceivers can lead to premature failures.



Warning

40G and 100G transceivers can become extremely hot. Always use their handles when installing or removing them from the switch to protect your hands from injury. An example is shown in Figure 116.

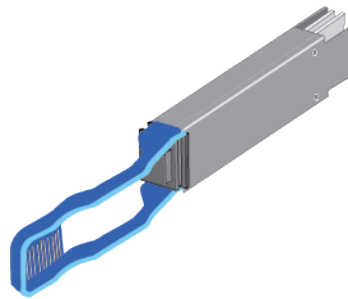


Figure 116. Handle on 40G and 100G Transceivers



Caution

Transceivers can be damaged by static electricity. Be sure to observe all standard electrostatic discharge (ESD) precautions, such as wearing an antistatic wrist strap, to avoid damaging the devices. *ES* E92

Installing Transceivers

Table 37 lists examples of the types of transceivers supported by the base transceiver slots. Refer to the product data sheet for a list of approved transceivers.

Table 37. Transceivers for the Base Transceiver Slots

Base Ports	Fiber Optic Transceiver
<p>Ports 1 to 24 on the AT-x950-28XSQ Switch</p> <p>Ports 1 to 48 on the AT-x950-52XSQ Switch</p>	<p>1Gbps SFP or 10Gbps SFP+ transceivers:</p> <ul style="list-style-type: none"> - 1Gbps SX/LX SFP transceivers - 10Gbps SR/LR SFP+ fiber optic transceivers - 1/10Gbps AT-SP10T transceiver with RJ-45 connector - 10Gbps AT-SP10TW direct attach twinax cables with SFP+ transceiver-style connectors - 1/2.5/5/10Gbps SFP+ transceivers with RJ-45 connectors
<p>Ports 25, 29, 33, and 37 on the AT-x950-28XSQ and AT-x950-28XTQm Switches</p> <p>Ports 49, 53, 57, and 61 on the AT-x950-52XSQ and AT-x950-52XTQm Switches</p>	<p>Examples of 100Gbps QSFP28 transceivers:</p> <ul style="list-style-type: none"> - AT-QSFP28-SR4 transceiver - Maximum operating distance of 70m (230 ft) or 100m (328 ft) with 12-strand OM3 or OM4 fiber optic cable, respectively. Requires a MPO pluggable optical connector. - AT-QSFP28-LR4 transceiver - Operating range of 2m (6.6 ft) to 10km (6.2 mi). Requires single-mode fiber optic cable with a duplex LC connector. <p>Examples of 40Gbps QSFP+ transceivers, direct attach cables, and breakout cables:</p> <ul style="list-style-type: none"> - AT-QSFPSR4 transceiver - requires 12-strand OM4 fiber optic cable and has a maximum operating distance of 150m (492 ft). - AT-QSFPLR4 transceiver - requires single-mode fiber optic cable and has an operating range of 2 meters (6.6 ft) to 10km (6.2 mi).

Table 37. Transceivers for the Base Transceiver Slots (Continued)

Base Ports	Fiber Optic Transceiver
Ports 25, 29, 33, and 37 on the AT-x950-28XSQ and AT-x950-28XTQm Switches Ports 49, 53, 57, and 61 on the AT-x950-52XSQ and AT-x950-52XTQm Switches	<ul style="list-style-type: none"> - AT-QSFP1CU and AT-QSFP3CU direct attach cables in lengths of 1 and 3 meters, respectively. - AT-QSFP-4SFP10G-3CU and AT-QSFP-4SFP10G-5CU breakout cables in lengths of 3 and 5 meters, respectively.

AT-SP10T and AT-SP10TM transceivers with RJ-45 connections require that adjacent ports be kept empty to prevent overheating. Refer to Figure 117.

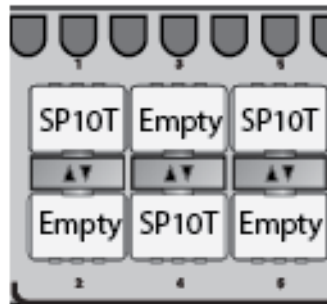


Figure 117. AT-SP10T Transceivers

Table 38 lists examples of the types of transceivers supported by the XEM2 Line Cards.

Table 38. Transceivers for the XEM2 Ethernet Line Cards

Ethernet Line Card	Transceiver
AT-XEM2-8XSTm	1Gbps SFP or 10Gbps SFP+ transceivers: <ul style="list-style-type: none"> - 1Gbps SX or LX SFP - 10Gbps SR or LR SFP+ - 10Gbps one meter AT-SP10TW1, three meter AT-SP10TW3, and seven meter AT-SP10TW7 direct attach twinax cables, with SFP+ transceiver-style connectors

Table 38. Transceivers for the XEM2 Ethernet Line Cards (Continued)

Ethernet Line Card	Transceiver
AT-XEM2-12XS	<p>1Gbps SFP or 10Gbps SFP+ transceivers:</p> <ul style="list-style-type: none"> - 1Gbps SX or LX SFP fiber optic transceivers - 10Gbps SR or LR SFP+ fiber optic transceivers - 10Gbps one meter AT-SP10TW1, three meter AT-SP10TW3, and seven meter AT-SP10TW7 direct attach twinax cables with SFP+ transceiver-style connectors (The AT-XEM2-12XS v2 Card does not support the AT-SP10TW7 cable.)
AT-XEM2-4QS	<p>40Gbps QSFP+ transceivers:</p> <ul style="list-style-type: none"> - AT-QSFPSR4 fiber optic transceiver - Maximum operating distance of 150 meters (492 feet) with 12-strand OM4 fiber optic cable. - AT-QSFPLR4 fiber optic transceiver - Operating range of 2 meters (6.6 feet) to 10 kilometers (6.2 miles) with single-mode fiber optic cable. - AT-QSFP1CU and AT-QSFP3CU direct attach cables - Lengths of 1 and 3 meters, respectively.
AT-XEM2-1CQ	<p>100Gbps QSFP28 transceivers:</p> <ul style="list-style-type: none"> - AT-QSFP28-SR4 fiber optic transceiver - Maximum operating distance of 70m (230 ft) or 100m (328 ft) with 12-strand OM3 or OM4 fiber optic cable, respectively. Requires a MPO pluggable optical connector. - AT-QSFP28-LR4 fiber optic transceiver - Operating range of 2m (6.6 ft) to 10km (6.2 mi). Requires single-mode fiber optic cable with a duplex LC connector. - AT-QSFP28-1CU and AT-QSFP28-3CU direct attach cables in lengths of one and three meters, respectively.

Please review “Guidelines to Handling Copper and Fiber Optic Transceivers” on page 187 before performing the procedure.

Your transceivers may look different than those shown in the following illustrations.



Warning

The temperature of an operational transceiver can exceed 70° C (158° F). Exercise caution when removing or handling transceivers with unprotected hands. E43

To install a fiber optic transceiver, perform the following procedure:

1. Select a port for the transceiver.
2. If the selected port has a dust cover, remove it.
3. Remove the transceiver from its shipping container and store the packaging material in a safe location.
4. Orient the transceiver and slide it into the port until it clicks into place. The correct orientation depends on the line card and transceiver:
 - ❑ Base ports 1 to 24 and AT-XEM2-8XSTm and AT-XEM2-12XS Line Cards - To install a transceiver in an odd numbered port, position it with its handle on top. To install a transceiver in an even numbered port, position it with its handle on the bottom. Refer to Figure 118 on page 191.

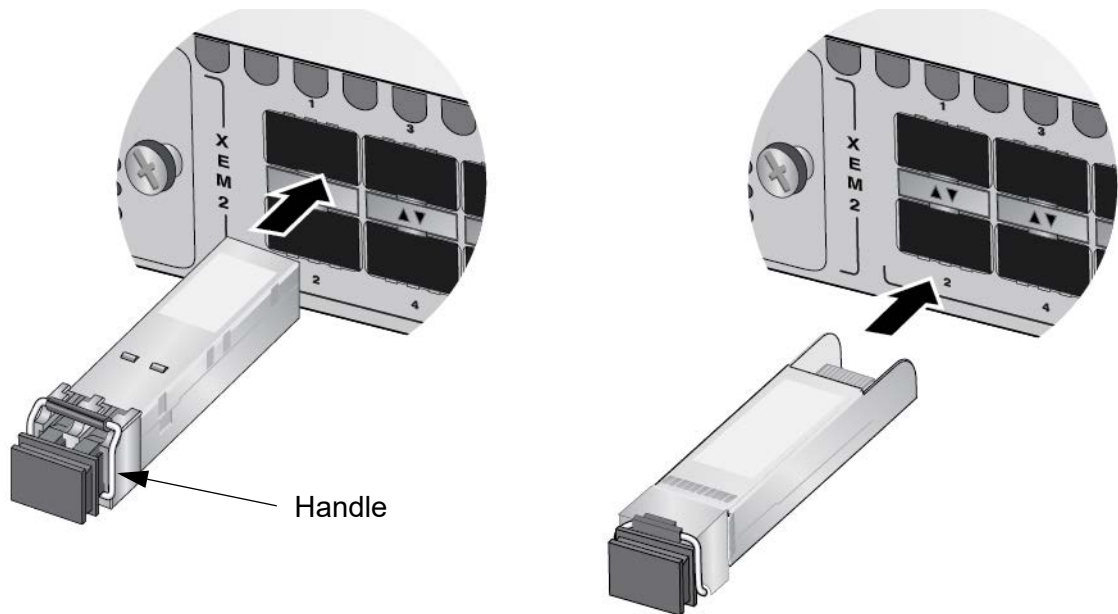


Figure 118. Installing an SFP or SFP+ Transceiver

- ❑ 40Gbps transceivers in the AT-XEM2-4QS Line Card - refer to Figure 119.

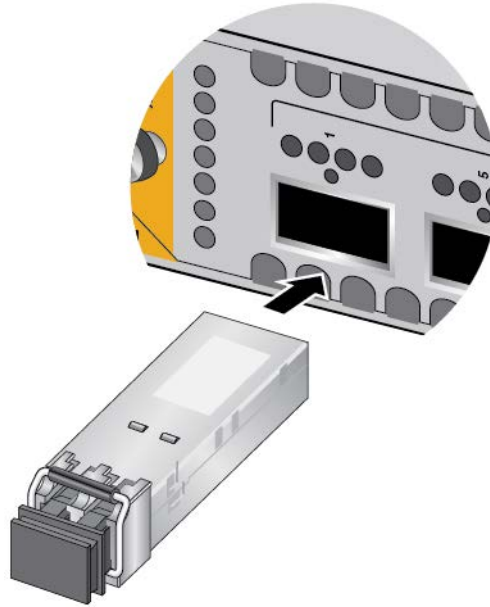


Figure 119. Installing 40Gbps Fiber Optic Transceivers in the AT-XEM2-4QS Line Card

- ❑ 100Gbps QSFP28 transceivers for base ports 25 to 37: refer to Figure 120.

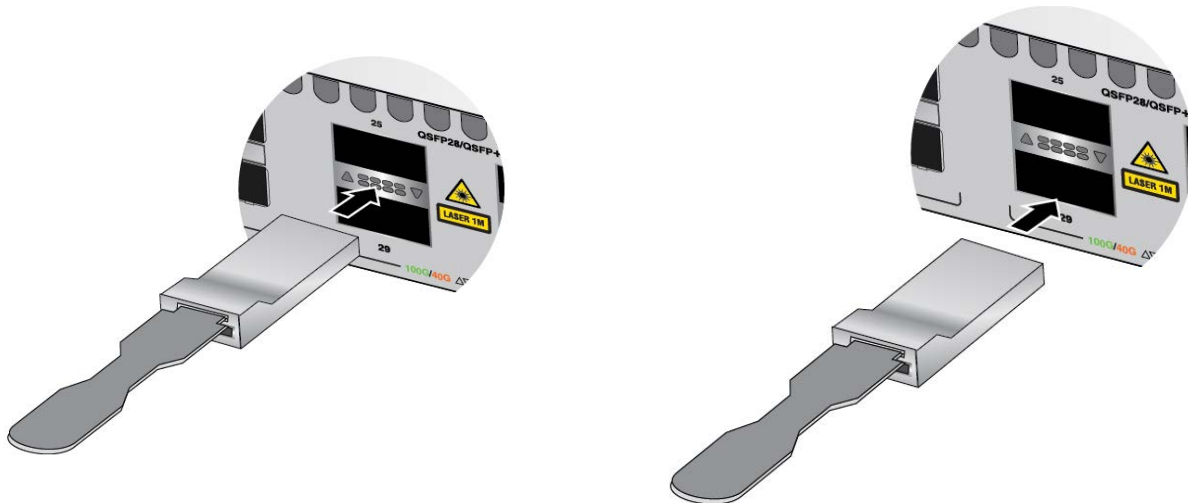


Figure 120. Installing 100Gbps QSFP28 Transceivers in Base Ports 25 to 37

- ❑ 100Gbps QSFP28 transceivers in the AT-XEM2-1CQ Line Card: refer to Figure 121.

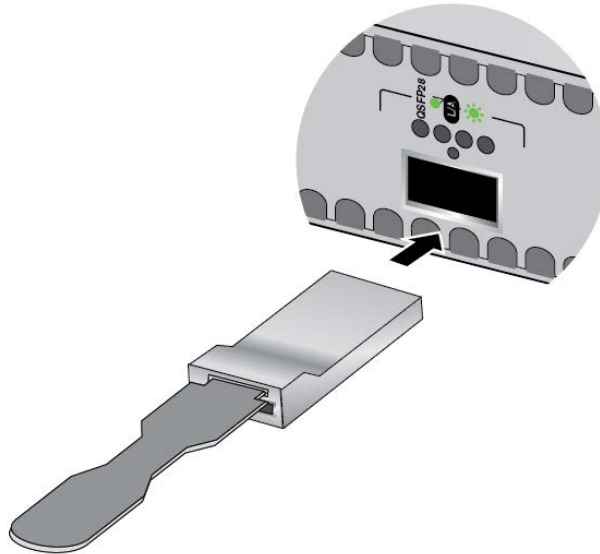


Figure 121. Installing 100Gbps QSFP28 Transceivers in the AT-XEM2-1CQ Line Card

Note

If you are ready to attach the fiber optic cable to the transceiver, continue with the next step. Otherwise, repeat steps 1 to 4 to install additional transceivers.

5. If the fiber optic connector on the transceiver has a dust cover, remove the cover.
6. Connect the fiber optic cable to the connector on the transceiver. The cable is keyed such that it can connect to the transceiver only one way.
7. Repeat this procedure to install additional transceivers.

Installing Direct Attach Cables

Table 12 on page 43 lists the direct attach cables for the base ports and XEM2 Line Cards. They offer an economical way to add 10Gbps, 40Gbps, or 100Gbps connections over short distances. To install direct attach cables, perform the following procedure:

1. Select a port for the direct attach cable.
2. If the selected port has a dust cover, remove the cover.
3. Remove the transceiver from its shipping container and store the packaging material in a safe location.
4. Orient the transceiver and slide it into the port until it clicks into place. The correct orientation depends on the cable:
 - Figure 122 shows the orientations for AT-SP10TW direct attach cables installed in base ports 1 to 24, and AT-XEM2-8XSTm and AT-XEM2-12XS Cards.



Figure 122. Installing AT-SP10TW Direct Attach Cables

- Figure 123 on page 195 shows the orientations for QSFPcU Cables installed in base ports 25 to 37.



Figure 123. Attaching QSFP+ Cables

5. Connect the other end of the cable into a compatible port on another network device.
6. Repeat this procedure to install additional direct attach cables.

Note

To remove a cable from the port, gently push on the connector, pull on the release tab, and slide the connector from the port.

Chapter 11

Replacing Modules

This chapter contains the following procedures:

- ❑ “Replacing XEM2 Ethernet Line Cards” on page 198
- ❑ “Replacing AT-PWR600 and AT-PWR600R AC Power Supplies” on page 203
- ❑ “Replacing AT-PWR600-80 and AT-PWR600R-80 DC Power Supplies” on page 208
- ❑ “Replacing AT-FAN05 and AT-FAN05R Modules” on page 211

Replacing XEM2 Ethernet Line Cards

This section contains the procedure for replacing XEM2 Line Cards in x950 Switches. The illustrations in the procedure show the XEM2-12XT Line Card. The procedure is the same for all cards. Please review the following guidelines before performing the procedure:

- ❑ All XEM2 Line Cards are hot-swappable. You do not have to power off or reboot the switch when installing or replacing a line card.
- ❑ XEM2 Line Cards might require up to thirty seconds before becoming fully operational after being powered on.

Note

Allied Telesis recommends saving a backup copy of the configuration file in the switch before removing or replacing line cards. For instructions, refer to the *Software Reference for x950 Switch, AlliedWare Plus Operating System*.

Note

The XEM2 Line Cards are also used in the SBx908 GEN2 Switch.

Note

You have to reboot the switch when hotswapping the AT-XEM2-1CQ Line Card.

This procedure requires the following tool:

- ❑ #2 Phillips-head screwdriver (not provided)

To remove an XEM2 Line Card from the switch, perform the following procedure:

1. Label and remove all cables from the line card.
2. If the line card has fiber optic transceivers, install dust covers on the ports.
3. If the line card has transceivers or direct attach cables, label and remove the transceivers or cables.

**Warning**

The temperature of an operational transceiver may exceed 70° C (158° F). Exercise caution when removing or handling transceivers with unprotected hands. ⚡ E43

Note

100Gbps transceivers for the AT-XEM2-1CQ Line Card have handles. Always use the handles when installing or removing transceivers.

4. Use a #2 Phillips-head screwdriver to loosen the two screws on the faceplate of the card. Refer to Figure 124.

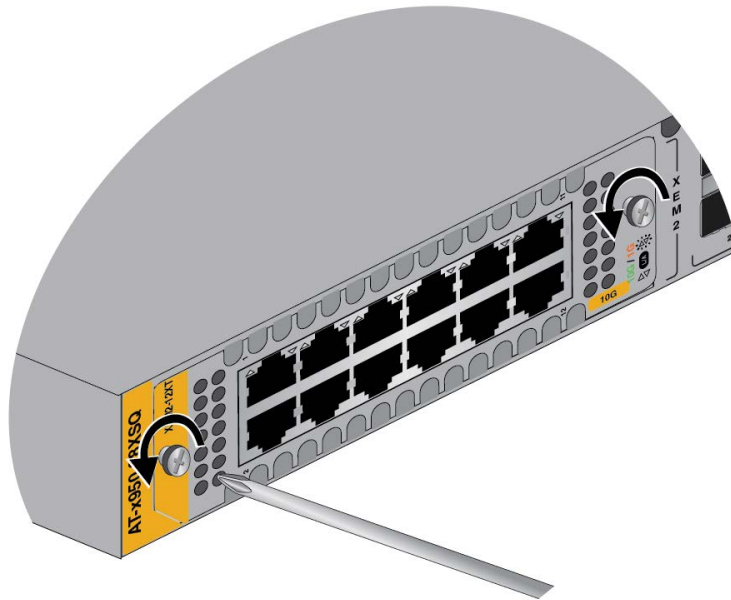


Figure 124. Loosening the Screws on the Ethernet Line Card

5. Carefully pull on the screws on the faceplate to disconnect the line card from the internal connector in the switch. Refer to Figure 125 on page 200.

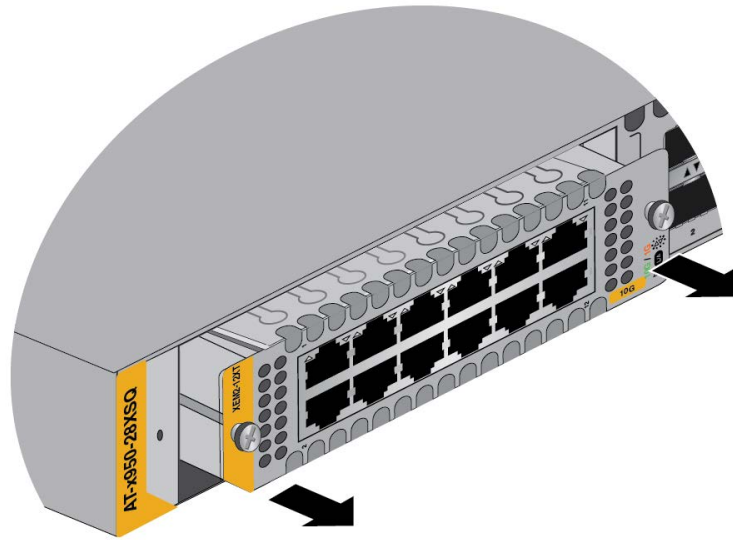


Figure 125. Disconnecting an Ethernet Line Card from the Switch

6. Carefully slide the card from the switch. Refer to Figure 126.

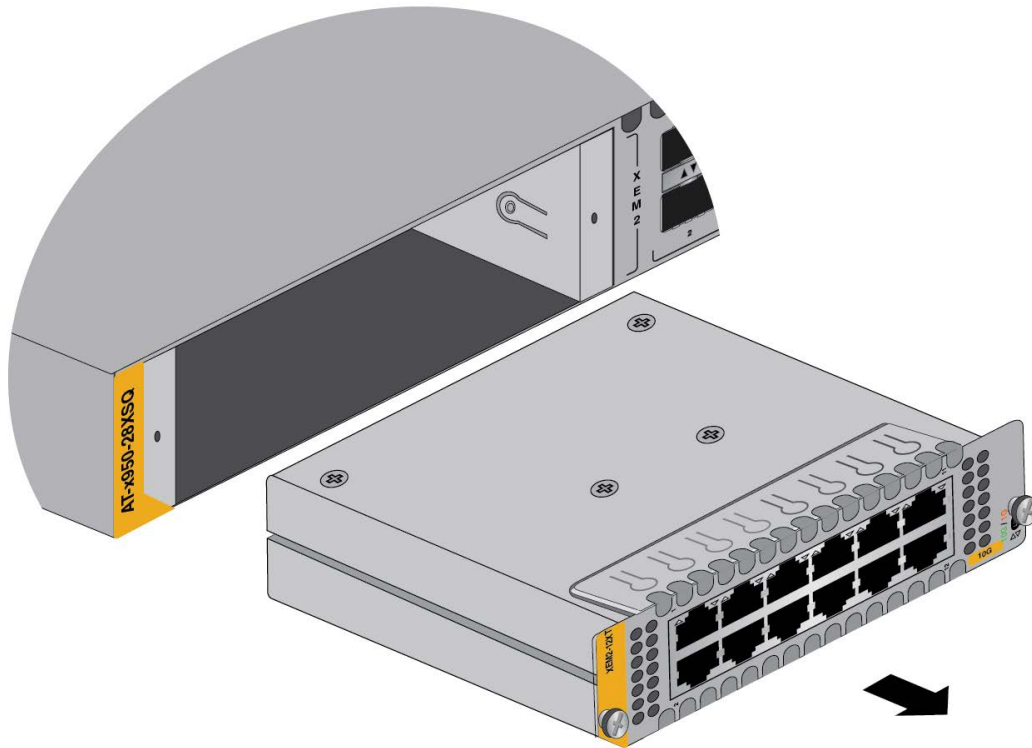


Figure 126. Sliding an Ethernet Line Card from the Switch

7. If you are not installing the line card in another switch, store it in its anti-static bag and shipping container. Refer to Figure 127.



Figure 127. Placing the XEM2 Line Card in its Anti-static Bag

8. Do one of the following:
- For instructions on how to install another card in the slot, start with step 2 in “Installing XEM2 Ethernet Line Cards” on page 106.
 - If you are not installing another line card in the slot now, continue with the next step to install the blank cover.
9. Orient the blank cover as shown in Figure 128, with the notch on the bottom left, and slid it into the slot.

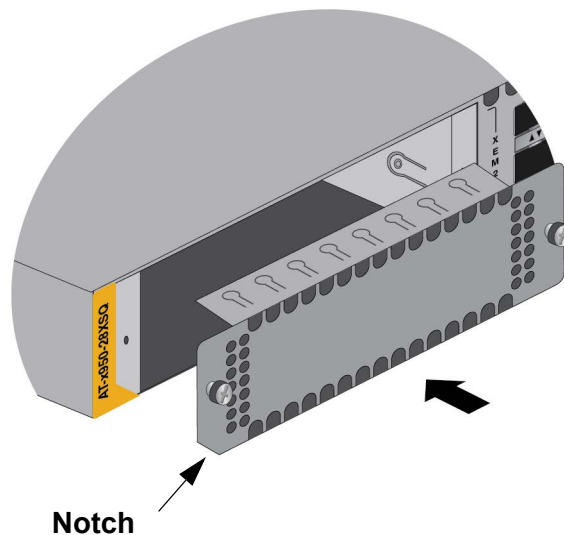


Figure 128. Installing the Line Card Blank Cover

10. Tighten the two screws to secure it to the switch. Refer to Figure 129.

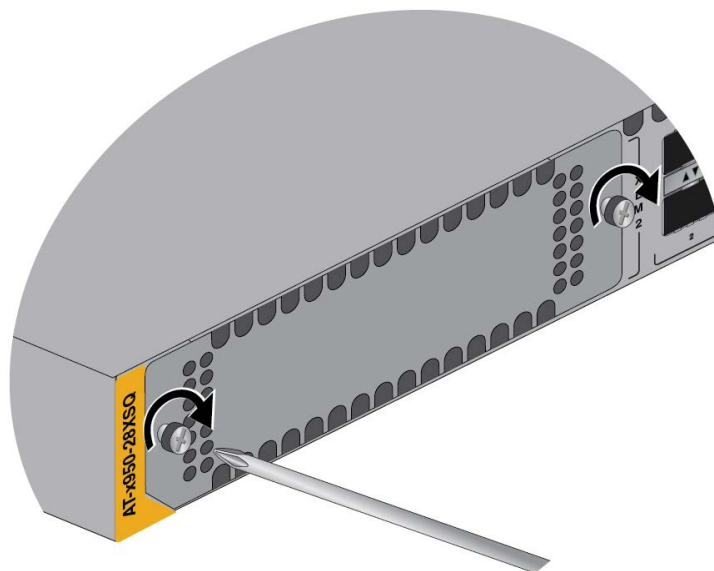


Figure 129. Tightening the Two Screws on the Line Card Blank Panel

Replacing AT-PWR600 and AT-PWR600R AC Power Supplies

This section contains the procedure for removing or replacing AT-PWR600 and AT-PWR600R AC Power Supplies. The following illustrations show the removal of a power supply from slot PSU A. The procedure is the same for replacing a power supply in slot PSU B.

Note

Allied Telesis recommends saving a backup copy of the configuration file in the switch before removing or replacing power supplies. For instructions, refer to the *Software Reference for x950 Switch, AlliedWare Plus Operating System*.

To remove AC power supplies from the switch, perform the following procedure:

1. Disconnect the AC power cord for the power supply from the AC power source. Refer to Figure 130.

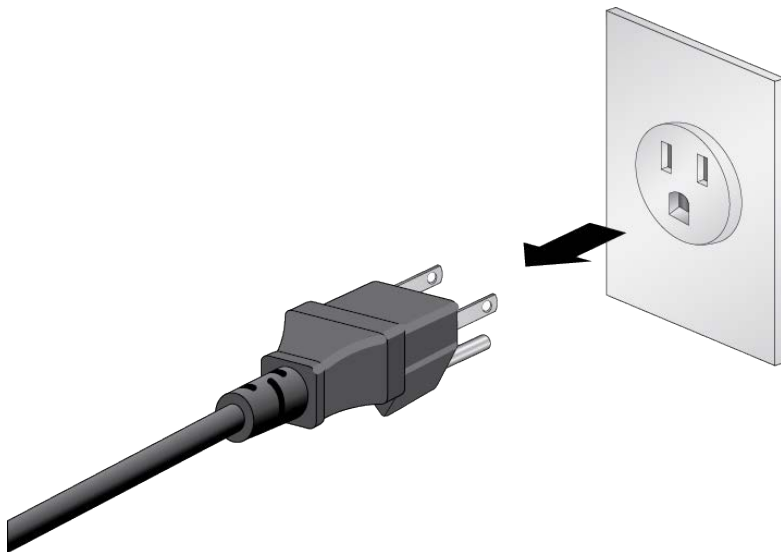


Figure 130. Disconnecting the AC Power Cord from the Power Source

2. Open the restraining strap on the power cord by pressing down on the release tab and pulling out the strap. Refer to Figure 131 on page 204.

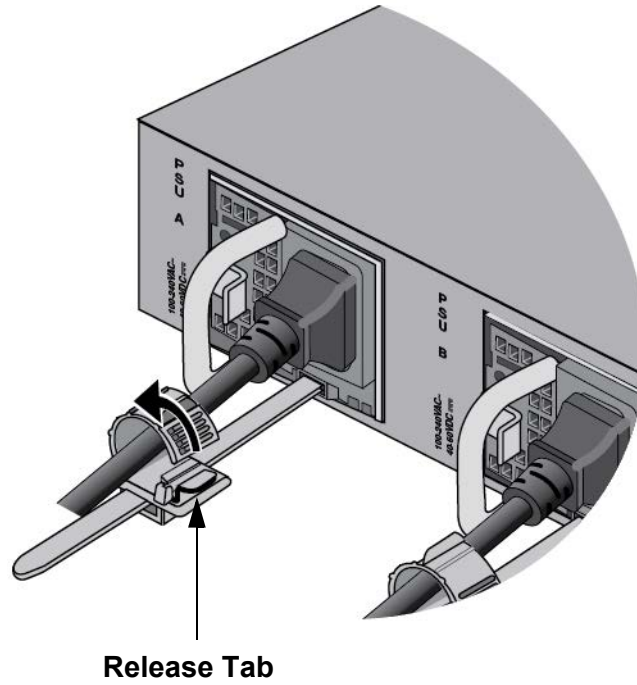


Figure 131. Opening the Restraining Strap on the Power Supply

3. Disconnect the power cord from the power supply. Refer to Figure 132.

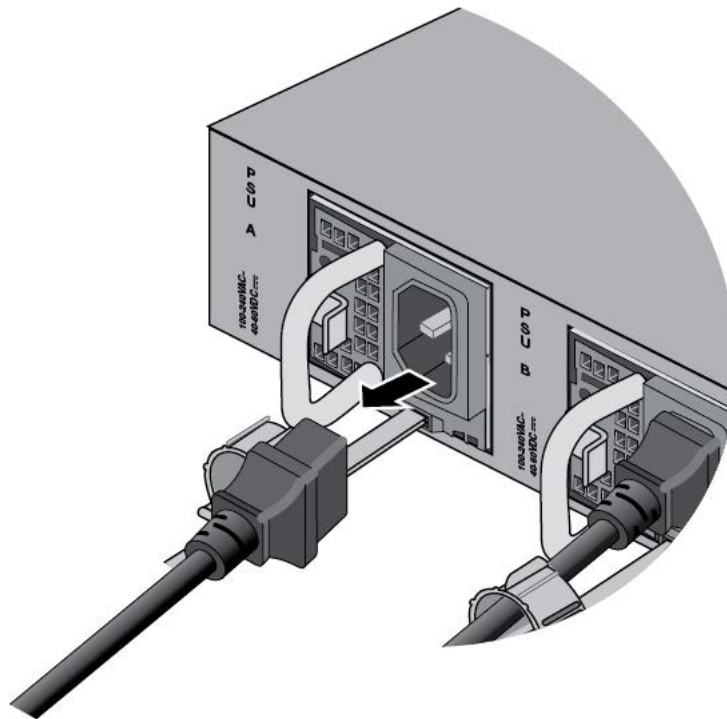


Figure 132. Disconnecting the Power Cord from the Power Supply

4. Press the release lever to the right and pull on the handle to release the power supply from the internal connector in the switch.

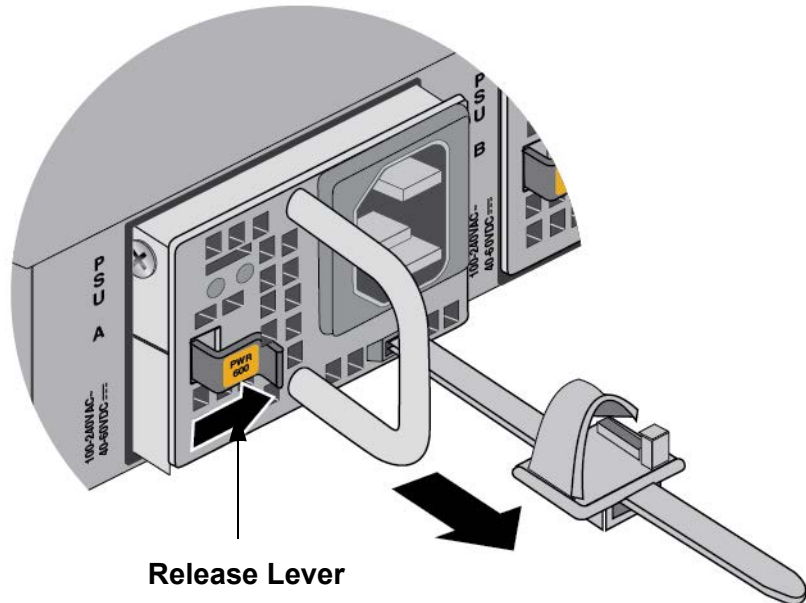


Figure 133. Removing the Power Supply

5. Carefully slide the power supply from the switch. Refer to Figure 134 on page 206.



Caution

The device is heavy. Use both hands to lift it. You might injure yourself or damage the device if you drop it. E94

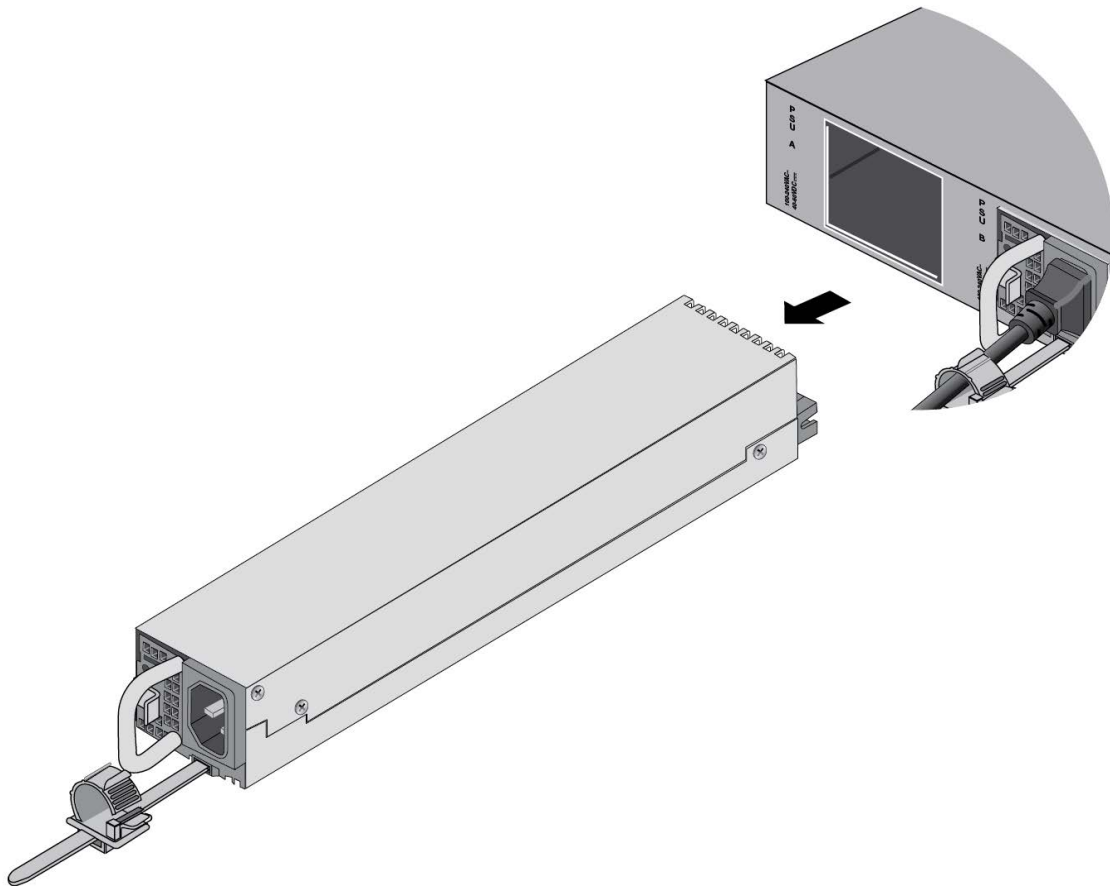


Figure 134. Removing a Power Supply

6. Do one of the following:
 - To install a new power supply, refer to “Installing AT-PWR600 and AT-PWR600R AC Power Supplies” on page 100 or “Replacing AT-PWR600-80 and AT-PWR600R-80 DC Power Supplies” on page 208 for instructions.
 - If you are not installing a new power supply, continue with the next step to install the blank panel.
7. Orient the blank power supply cover as shown in Figure 135 on page 207 and slide it into the slot until it clicks into place.

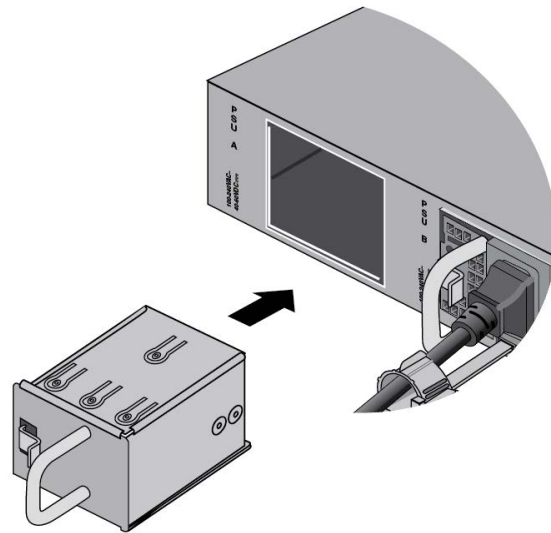


Figure 135. Installing the Blank Power Supply Cover

Replacing AT-PWR600-80 and AT-PWR600R-80 DC Power Supplies

This section contains the procedure for removing or replacing AT-PWR600-80 and AT-PWR600R-80 DC Power Supplies.

Note

Allied Telesis recommends saving a backup copy of the configuration file in the switch before removing or replacing power supplies. For instructions, refer to the *Software Reference for x950 Switch, AlliedWare Plus Operating System*.

To remove DC power supplies from the switch, perform the following procedure:

1. Power off the DC power supply.
2. Loosen the screw for the connector panel with a Phillips-head screwdriver. Refer to Figure 136.

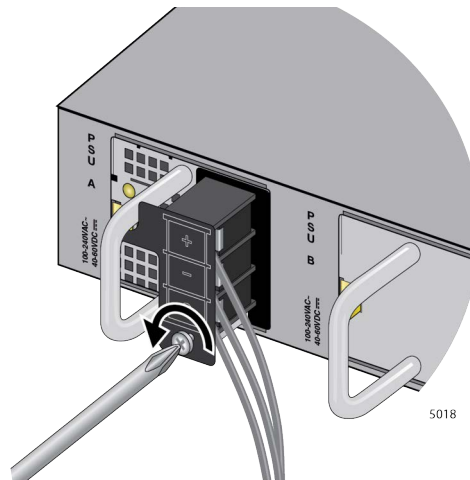


Figure 136. Loosening the Screw for the Panel

3. Press the panel to the right to access the connecting screws as shown in Figure 137 on page 209.

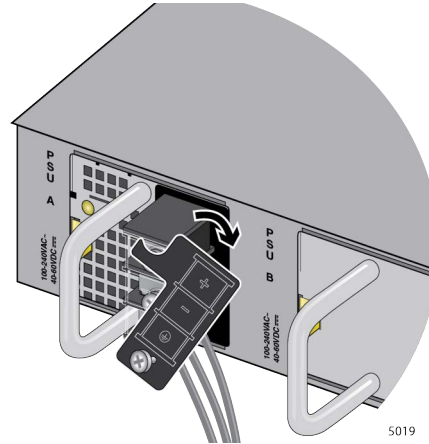


Figure 137. Accessing the Connecting Screws

4. Loosen all three screws for the ground wire, positive (+) and negative (-) wires.
5. Remove all three wires.
6. Press the release lever to the right and pull on the handle to release the power supply from the internal connector in the switch. Refer to Figure 133 on page 205.

The release lever and handle are shown in Figure 138.

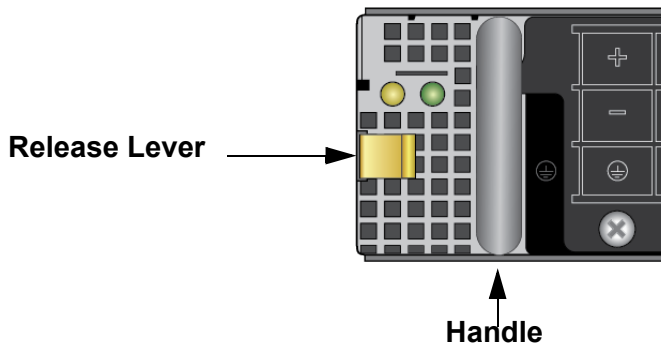


Figure 138. Front Panel of the PWR600 DC Power Supply

7. Carefully slide the power supply from the switch. Refer to Figure 139 on page 210.



Caution

The device is heavy. Use both hands to lift it. You might injure yourself or damage the device if you drop it. E94

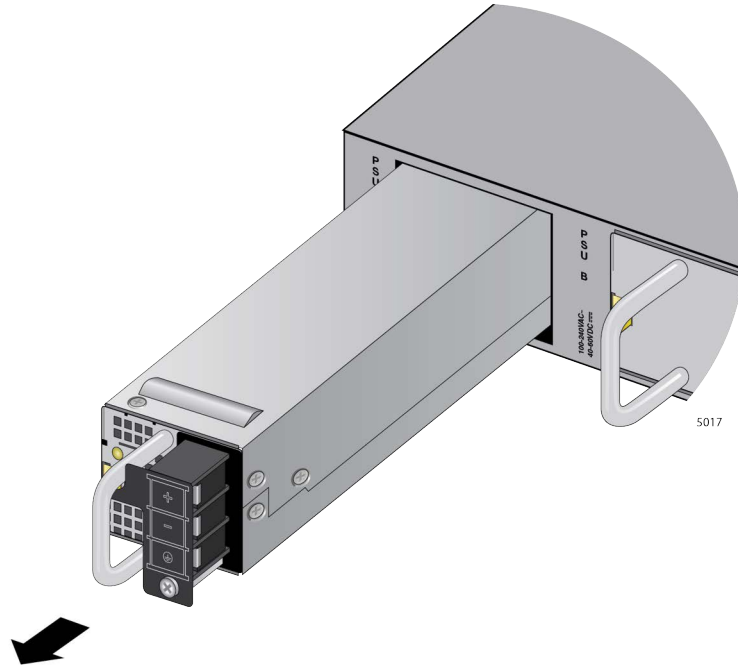


Figure 139. Removing a DC Power Supply

8. Do one of the following:
 - To install a new power supply, refer to “Installing AT-PWR600 and AT-PWR600R AC Power Supplies” on page 100 or “Installing AT-PWR600-80 and AT-PWR600R-80 DC Power Supplies” on page 104 for instructions.
 - If you are not installing a new power supply, continue with the next step to install the blank panel.
9. Orient the blank power supply cover as shown in Figure 135 on page 207 and slide it into the slot until it clicks into place.
10. Remove the ground wire from the ground point at the installation site.

Replacing AT-FAN05 and AT-FAN05R Modules

This section contains the procedure for replacing AT-FAN05 and AT-FAN05R Modules. Fan modules are hot swappable. You can replace them without having to power off the switch. For background information, refer to “AT-FAN05 and AT-FAN05R Fan Modules” on page 52.

Note

Allied Telesis recommends saving a backup copy of the configuration file in the switch before replacing a fan module. For instructions, refer to the Software Reference for x950 Switches.

Removing Fan Modules

This procedure requires the following tool:

- #2 Phillips-head screwdriver (not provided)

The illustrations show the removal of the fan module from FAN B slot on the back panel. The procedure is the same for removing a module from FAN A slot.

To remove a fan module from the switch, perform the following procedure:

1. Use a #2 Phillips-head screwdriver to loosen the two screws on the faceplate of the fan module. Refer to Figure 140.

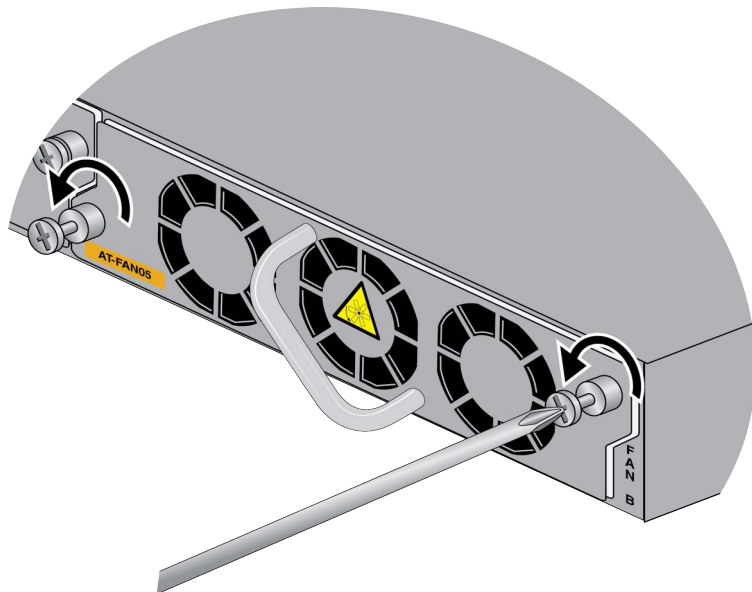


Figure 140. Loosening the Screws on the Fan Module

2. Carefully pull on the handle to disconnect the line card from the internal connector in the switch. Refer to Figure 141.

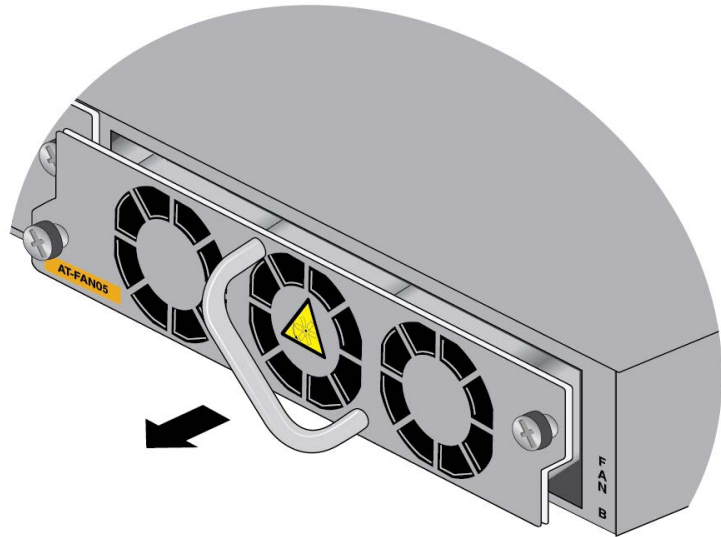


Figure 141. Disconnecting the Fan Module from the Switch

3. Slide the fan module out of the switch. Refer to Figure 142.

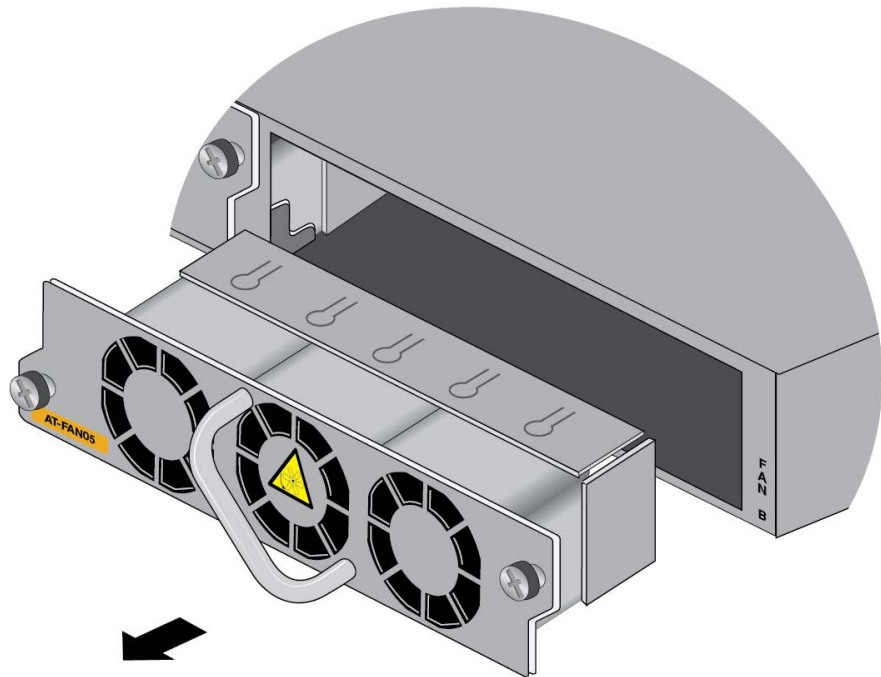


Figure 142. Sliding the Fan Module from the Switch

4. Continue with the next procedure to install a new AT-FAN05 Module.

Installing Fan Modules

This procedure requires the following tool:

- #2 Phillips-head screwdriver (not provided)

The illustrations show the installation of a fan module in FAN B slot on the back panel. The procedure is the same for installing a module in FAN A slot.

To install a fan module, perform the following procedure:

1. Remove the new fan module from its shipping box. Refer to Figure 143.

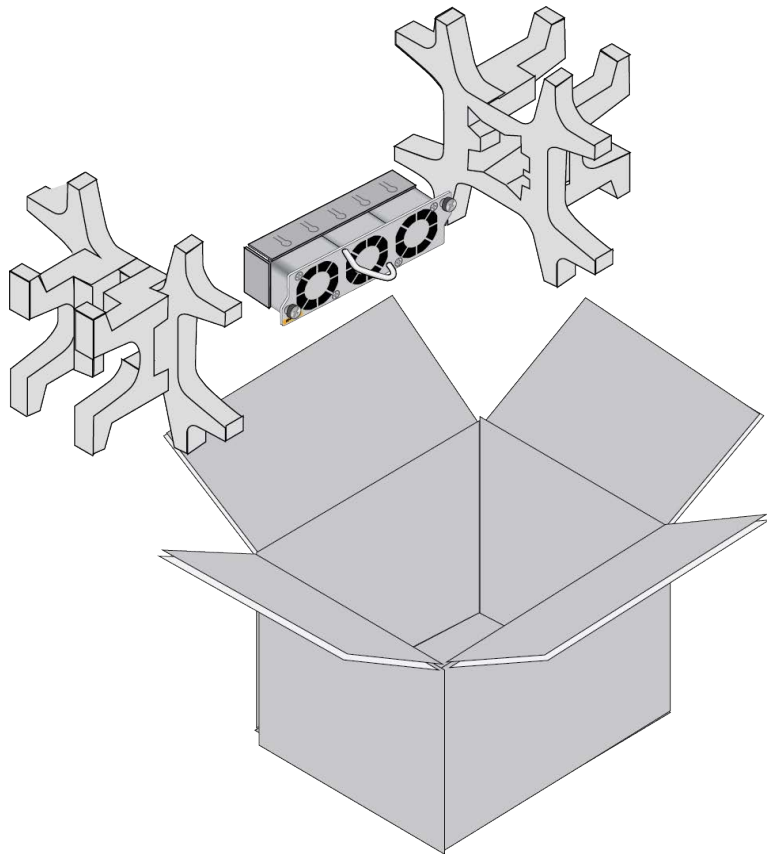


Figure 143. Removing the Fan Module from the Shipping Container

2. Align the fan module in the slot. Refer to Figure 144 on page 214.

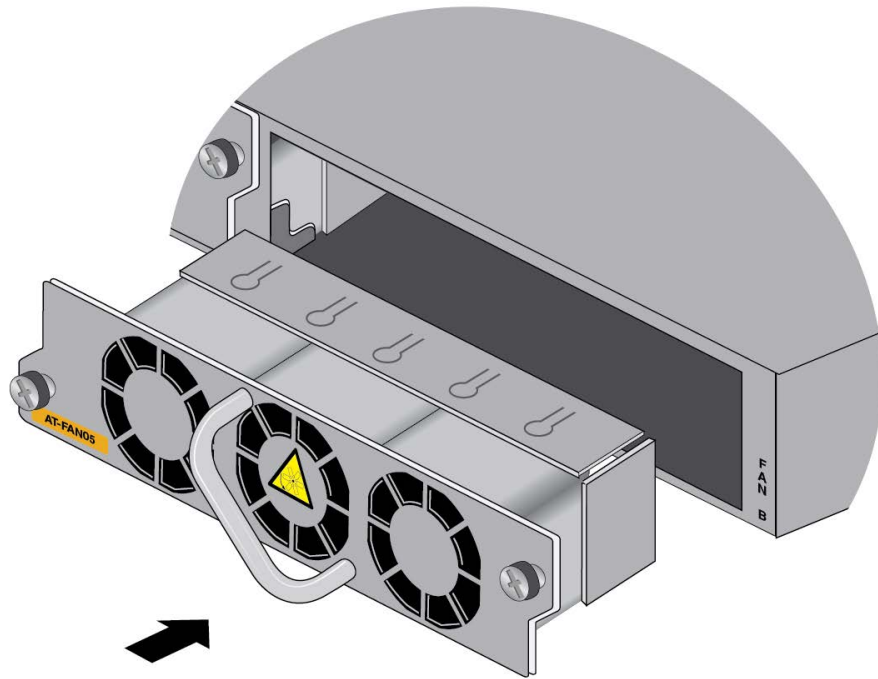


Figure 144. Aligning the AT-FAN05 Module in the Switch Slot

3. When you feel the module make contact with the internal connector, gently press on both sides to seat the module on the connector. Refer to Figure 145.

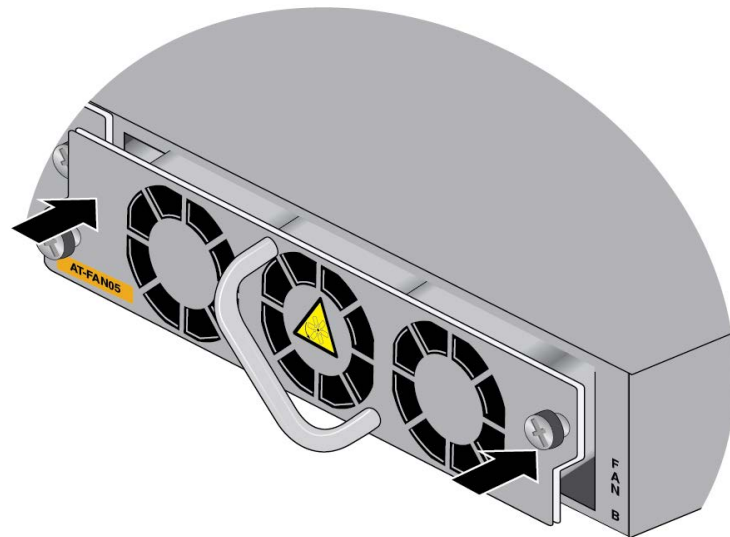


Figure 145. Seating the Fan Module on the Internal Connector

4. Tighten the two screws on the module to secure it to the switch. Refer to Figure 146.

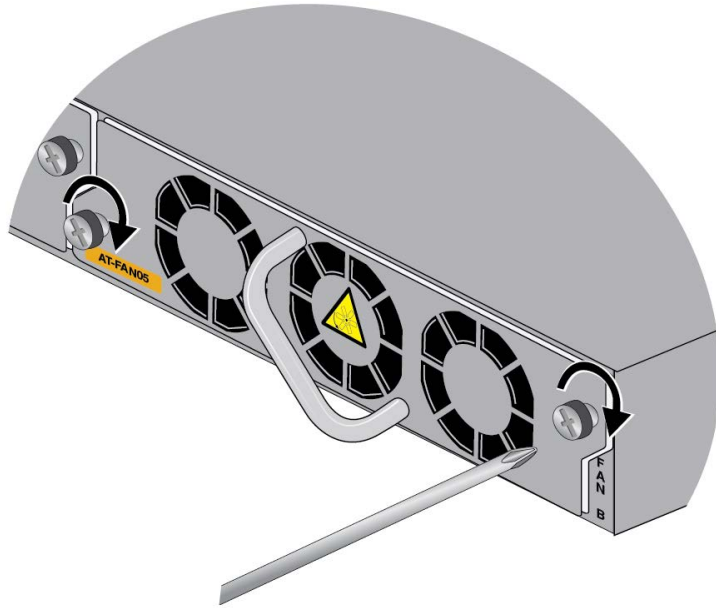


Figure 146. Tightening the Two Captive Screws on the Fan Module

5. To confirm the operations of the new fan module, start a local or remote management session and enter the `SHOW SYSTEM ENVIRONMENT` command in the User Exec or Privileged Exec mode. For directions, refer to “Verifying the Switch with AlliedWare Plus Commands” on page 177.

Chapter 12

Troubleshooting

This chapter contains suggestions on how to troubleshoot problems with the switch.

Note

For further assistance, please contact Allied Telesis Technical Support at www.alliedtelesis.com/support.

Problem 1: The unit is not receiving power. All the port LEDs and Switch ID LED are off, and the fans are not operating.

Solutions: Try the following:

- Verify that the power cord is securely connected to the power source and AC connector on the back panel of the switch.
- Verify that the DC power wires are securely connected to the screws on the front panel and to the DC power source unit.
- Verify that the power outlet has power by connecting another device to it.
- Try connecting the unit to another power source.
- Try a different power cord.
- Verify that the voltage from the power source is within the required levels for your region. The power requirements for the switch are listed in “Power Specifications” on page 229.
- Try replacing the power supply.

Note

Power supplies are hot swappable. If the chassis has two power supplies and one fails, you can replace the failed unit without having to power off the operational power supply.

Problem 2: All the port LEDs are off even though the ports are connected to active network devices.

Solution: The switch might be operating in the low power mode. To toggle on the LEDs, press the eco-friendly button on the front panel of the switch. You can also toggle the LEDs off and on with the ECOFRIENDLY LED and NO ECOFRIENDLY LED commands in the command line interface.

Problem 3: A 1G or 10G fiber optic transceiver in a base port (ports 1 to 24 for the AT-x950-28XSQ Switch, or port 1 to 48 for the AT-x950-52XSQ Switch) is unable to establish a link to a network device.

Solutions: Try the following:

- ❑ Check that the transceiver is fully inserted in the port.
- ❑ Verify that the fiber optic cable is securely connected to the port on the transceiver and the remote network device.
- ❑ Verify that the remote network device is operating properly.
- ❑ Verify that the operating specifications of the fiber optic ports on the transceiver and remote network device are compatible.
- ❑ Verify that the correct type of fiber optic cabling is being used.
- ❑ Verify that the port is connected to the correct fiber optic cable.
- ❑ Try connecting another network device to the fiber optic port using a different cable. If the port is able to establish a link, then the problem is with the cable or with the other network device.
- ❑ Use the switch's management software to verify that the port is enabled.
- ❑ If the remote network device is a managed device, use its management firmware to determine whether its port is enabled.
- ❑ If the problem is with two BiDi (bi-directional) transceivers, refer to their data sheets to verify that their transmission and reception frequencies are opposite each other. For instance, a BiDi transceiver that transmits and receives at 1310nm and 1550nm, respectively, has to be connected to a transceiver that transmits and receives at 1550nm and 1310nm, respectively. Two BiDi transceivers will not establish a link if they transmit and receive at the same frequencies.
- ❑ Test the attenuation of both directions on the fiber optic cable with a fiber optic tester to determine whether the optical signal is too weak or strong.

Problem 4: A 40G or 100G fiber optic transceiver in port 25, 29, 33, or 37 on the AT-x950-28XSQ or AT-x950-28XTQm Switch or port 49, 53, 57, or 61 on the AT-x950-52XSQ or AT-x950-52XTQm Switch cannot establish a link with a network device.

Solutions: Try the following:

- ❑ Review the solutions in Problem 3.
- ❑ Use the SHOW PLATFORM command to confirm that the port is configured correctly for an 100G fiber optic transceiver. If necessary, perform “Configuring Ports for 40G QSFP+ and 100G QSFP28 Transceivers, and Breakout Cables” on page 181.

Changing a port from a 40G transceiver or breakout cable to a 100G transceiver requires resetting the switch. The same is also true when replacing a 100G transceiver with a 40G transceiver or breakout cable.

- ❑ If the problem is with an 100G transceiver, you might need to adjust the Forward Error Correction (FEC) parameter on the port, with the FEC command. Refer to the *Software Reference for x950 Switch, AlliedWare Plus Operating System*.

Problem 5: A 4x10G breakout cable in port 25, 29, 33, or 37 on the AT-x950-28XSQ or AT-x950-28XTQm Switch, or port 49, 53, 57, or 61 on the AT-x950-52XSQ-52XSQ or AT-x950-52XTQm Switch cannot establish links with network devices.

Solutions: Try the following:

- ❑ Check that the cable is fully inserted in the port in the switch.
- ❑ Verify that the breakout cables are securely connected to the ports on the network devices.
- ❑ Use the SHOW PLATFORM command to confirm that the port is configured for a breakout cable. If necessary, perform “Configuring Ports for 40G QSFP+ and 100G QSFP28 Transceivers, and Breakout Cables” on page 181.
- ❑ If the port previously had a 100G transceiver, you must reset the switch after configuring it for a breakout cable.

Problem 6: An XEM2 Line Card in the expansion slot is not functioning.

Solutions: Try the following:

- ❑ Visually inspect the card to verify that it is fully inserted into the expansion slot.
- ❑ If the problem is with an AT-XEM2-12XTm Card, the switch might have an earlier version of the AlliedWare Plus software that does not support the card. The card requires v5.4.9-1 or later. Use the SHOW VERSION command to display the version number. If necessary, update the management software.
- ❑ Try installing the card in a different switch. If it still does not work, the problem is probably with the card. Replace the card.
- ❑ Try installing a different card in the switch. If the replacement card fails to work, the problem is probably with the switch. Contact your Allied Telesis sales representative for assistance.

Problem 7: An SFP, SFP+, or QSFP+ transceiver in an XEM2 Line Card is unable to establish a link to another network device.

Solutions: Try the solutions to Problem 3.

Problem 8: A copper port in the AT-x950-28XTQm or AT-x950-52XTQm Switch, or the AT-XEM2-12XT or AT-XEM2-12XTm Line Card cannot establish a link with a network device.

Solutions: Try the following:

- ❑ Verify that the network device connected to the copper port is powered on and is operating properly.
- ❑ Verify that the network device operates at a speed supported by the card. The ports on the AT-XEM2-12XT Card support 100M and 1/10G. The ports on the AT-x950-28XTQm and AT-x950-52XTQm Switch, and AT-XEM2-8XSTm and AT-XEM2-12XTm Cards support 100M and 1/2.5/5/10G. The cards do not support 10M devices.
- ❑ If the AT-XEM2-12XT Card cannot establish links with 100M devices, the switch might have an earlier version of the AlliedWare Plus management software. Support for 100M devices on the AT-XEM2-12XT Card requires version 5.4.9-1 or later. Use the SHOW VERSION command to display the version number. If necessary, update the management software.
- ❑ Try connecting another network device to the copper port with a different cable. If the copper port is able to establish a link, then the problem is with the cable or the other network device.
- ❑ Verify that the cable does not exceed 100 meters (328 feet).
- ❑ Verify that you are using the appropriate category of cable. Cable requirements are listed in “Cabling Copper Ports” on page 186.
- ❑ Verify that the port is connected to the correct cable.

Note

An 1G/10G connection may require five to ten seconds to establish a link.

Problem 9: The switch overheats and shuts down.

Solutions: Try the following:

- ❑ Verify that the location of the switch allows for adequate airflow.
- ❑ If the switch is operating, use the SHOW SYSTEM ENVIRONMENT command in the Privileged Exec mode to verify that the power supplies and fan modules are operating properly.
- ❑ Verify that the power supplies and fan modules have the same airflow direction. Refer to Table 13 on page 44 or Table 16 on page 52.

Problem 10: The switch functions intermittently.

Solutions: Try the following:

- ❑ Use the SHOW SYSTEM ENVIRONMENT command in the Privileged Exec mode to verify that the input voltage from the power source to the switch is stable and within the approved operating range. The unit will shut down if the input voltage fluctuates above or below the approved operating range.
- ❑ Use the SHOW SYSTEM ENVIRONMENT command to verify that the fan modules are operating correctly.
- ❑ Verify that the location of the switch allows for adequate airflow. The unit will shut down if it is overheating.
- ❑ Verify that the power supplies and fan modules have the same airflow direction. Refer to Table 13 on page 44 or Table 16 on page 52.

Problem 11: The System Airflow status in the SHOW SYSTEM ENVIRONMENT command displays “INCOMPATIBLE.”

Solution: The power supplies and fan modules in the switch have different airflow directions. Refer to Table 13 on page 44 or Table 16 on page 52 for airflow information. Replace power supplies and/or fan modules so that they have the same airflow direction.

Problem 12: The Switch ID LED in the management panel is flashing “F.”

Solutions: One of the following problems has occurred:

- ❑ A cooling fan has failed. Use the SHOW SYSTEM ENVIRONMENT command to verify that the fan modules are operating correctly.
- ❑ The internal temperature of the switch is outside the normal operating range and the unit might shut down. The installation site might not provide enough ventilation for the device. Increase the ventilation at the site.
- ❑ Verify that the power supplies and fan modules have the same airflow direction. Refer to Table 13 on page 44 or Table 16 on page 52.

For further assistance, contact your Allied Telesis sales representative.

Appendix A

Technical Specifications

This appendix contains the following sections:

- "Physical Specifications" on page 224
- "Environmental Specifications" on page 228
- "Power Specifications" on page 229
- "Certifications" on page 240
- "RJ-45 Copper Port Pinouts" on page 241
- "RJ-45 Style Serial Console Port Pinouts" on page 243

Physical Specifications

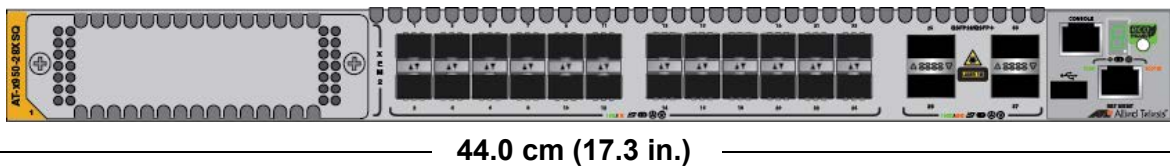
Dimensions (H x W x D)

Table 39 lists the dimensions of the switches, power supplies, and fan modules.

Table 39. Product Dimensions

AT-x950-28XSQ AT-x950-28XTQm	4.4 cm x 44.0 cm x 44.5 cm (1.7 in. x 17.3 in. x 17.5 in.)
AT-x950-52XSQ AT-x950-52XTQm	4.4 cm x 44.0 cm x 44.7 cm (1.7 in. x 17.3 in. x 17.6 in.)
AT-XEM2-8XSTm AT-XEM2-12XT AT-XEM2-12XTm AT-XEM2-12XS AT-XEM2-12XS v2 AT-XEM2-4QS AT-XEM2-1CQ	4.0 x 13.0 x 16.6 cm (1.57 x 5.11 x 6.53 in.)
AT-PWR600 AT-PWR600R	5.1 cm x 4.0 cm x 24.5 cm (2.0 in. x 1.6 in. x 9.6 in.)
AT-PWR600-80 AT-PWR600R-80	5.1 cm x 4.0 cm x 24.5 cm (2.0 in. x 1.6 in. x 9.6 in.)
AT-FAN05 AT-FAN05R	4.3 cm x 15.2 cm x 10.0 cm (1.7 in. x 6.0 in. x 3.9 in.)

Width (All Models)



Height (All Models)

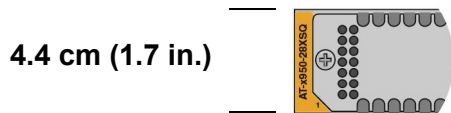
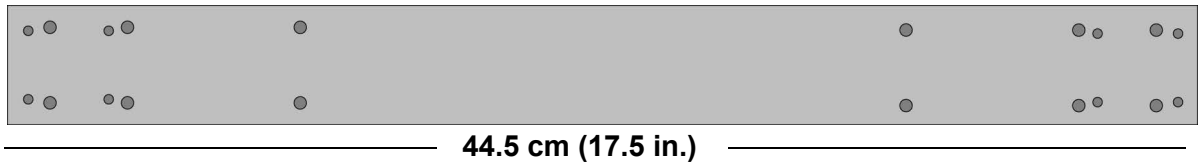


Figure 147. Switch Width and Height

The side dimension and locations of the bracket holes for the AT-x950-28XSQ and AT-x950-28XTQm Switches are shown in Figure 148.

Depth (AT-x950-28XSQ and AT-x950-28XTQm)



Bracket Hole Locations (AT-x950-28XSQ and AT-x950-28XTQm)

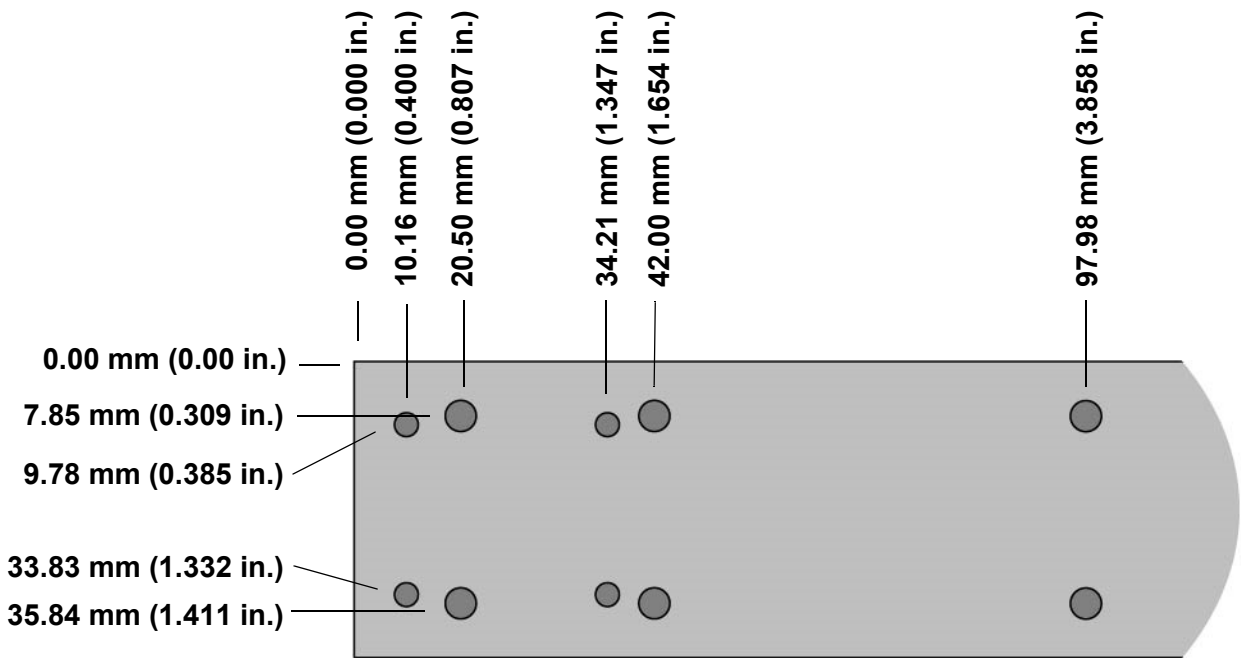
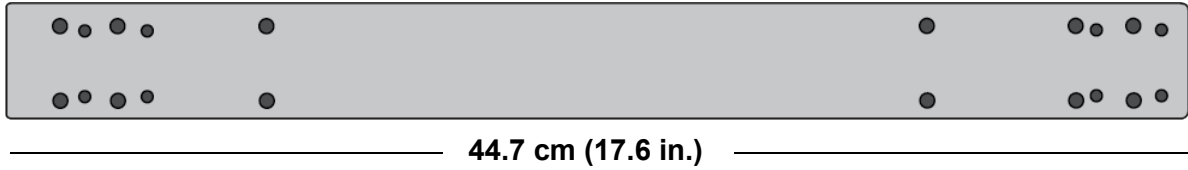


Figure 148. Switch Depth and Locations of Bracket Holes for the AT-x950-28XSQ and AT-x950-28XTQm Switches

The side dimension and bracket holes for the AT-x950-52XSQ and AT-x950-52XTQm Switches are shown in Figure 149 on page 226.

Depth (AT-x950-52XSQ and AT-x950-52XTQm)



Bracket Hole Locations (AT-x950-52XSQ and AT-x950-52XTQm)

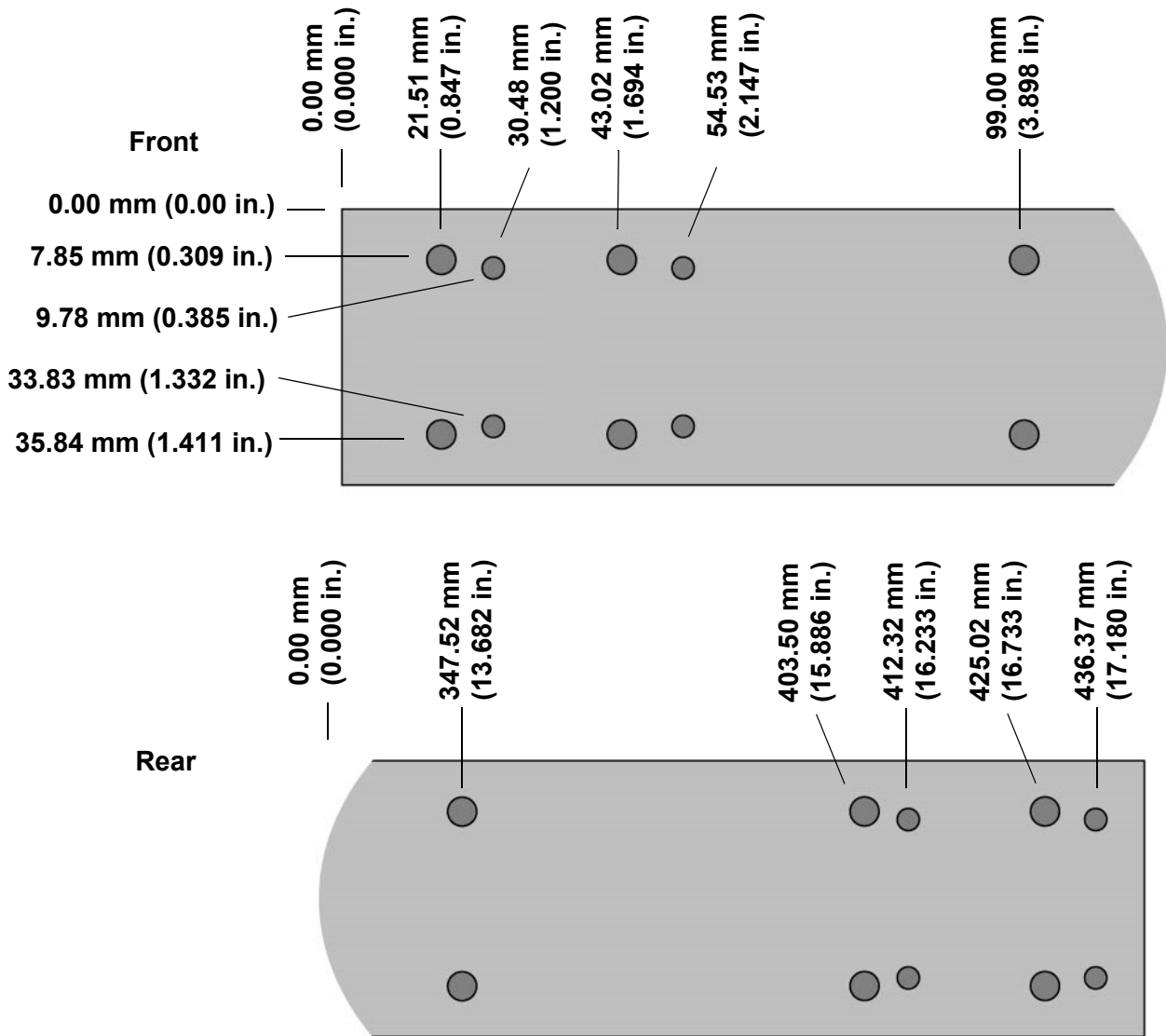


Figure 149. Switch Depth and Bracket Holes for AT-x950-52XSQ and AT-x950-52XTQm Switches

Weights

Table 40 lists the weights of the switches and components.

Table 40. Product Weights

AT-x950-28XSQ Switch	7.21 kg (15.90 lb.)
AT-x950-28XTQm Switch	7.33 kg (16.15 lb.)
AT-x950-52XSQ Switch	7.35 kg (16.2 lb.)
AT-x950-52XTQm Switch	8.20 kg (18.08 lb.)
AT-XEM2-8XSTm Line Card	0.70 kg (1.54 lb.)
AT-XEM2-12XT Line Card	0.75 kg (1.65 lb.)
AT-XEM2-12XTm Line Card	1.04 kg (2.3 lb.)
AT-XEM2-12XS Line Card	0.75 kg (1.65 lb.)
AT-XEM2-12XS v2 Line Card	0.73 kg (1.60 lb.)
AT-XEM2-4QS Line Card	0.66 kg (1.45 lb.)
AT-XEM2-1CQ Line Card	0.62 kg (1.37 lb.)
AT-PWR600 AC	0.68 kg (1.5 lb.)
AT-PWR600-80 DC	0.77 kg (1.7 lb.)
AT-FAN05	0.34 kg (0.75 lb.)

The weights of the switches include two cooling fan modules. They do not include power supplies or line card.

Ventilation

Table 41 lists the ventilation requirements.

Table 41. Ventilation Requirements

Recommended Minimum Ventilation on All Sides	10 cm (4.0 in)
--	----------------

Environmental Specifications

Table 42 lists the environmental specifications of the switches.

Table 42. Environmental Specifications

Operating Temperature (with QSFP28 transceivers)	0° C to 45° C (32° F to 113° F)
Operating Temperature (without QSFP28 transceivers)	0° C to 50° C (32° F to 122° F)
Storage Temperature	-25° C to 70° C (-13° F to 158° F)
Operating Humidity	5% to 90% noncondensing
Storage Humidity	5% to 95% noncondensing
Maximum Operating Altitude	3,000 m (9,842 ft)
Maximum Nonoperating Altitude	4,000 m (13,100 ft)

Power Specifications

This section contains the maximum power consumption values and input voltages.

Maximum Power Consumptions

Table 43 lists the maximum power consumptions for the AT-x950-28XSQ Switch.

Table 43. Maximum Power Consumptions (Watts) for the AT-x950-28XSQ Switch

AT-x950-28XSQ Switch and Line Card	PWR600	Number of Power Supplies	Maximum Power Consumption
Switch - No card	AC	1	206.08 W
		2	231.22 W
	DC	1	201.85 W
		2	218.66 W
Switch plus AT-XEM2-4QS Card	AC	1	224.55 W
		2	248.04 W
	DC	1	219.80 W
		2	236.11 W
Switch plus AT-XEM2-12XT Card	AC	1	251.07 W
		2	271.85 W
	DC	1	246.27 W
		2	261.69 W
Switch plus AT-XEM2-12XS Card	AC	1	240.40 W
		2	262.30 W
	DC	1	235.66 W
		2	251.44W

Table 43. Maximum Power Consumptions (Watts) for the AT-x950-28XSQ Switch (Continued)

AT-x950-28XSQ Switch and Line Card	PWR600	Number of Power Supplies	Maximum Power Consumption
Switch plus AT-XEM2-1CQ Card	AC	1	213.63 W
		2	238.19 W
	DC	1	209.36 W
		2	226.04 W
Switch plus AT-XEM2-12XTm Card	AC	1	239.96 W
		2	261.64 W
	DC	1	233.73 W
		2	249.67 W
Switch plus AT-XEM2-12XS v2 Card	AC	1	233.38 W
		2	256.32 W
	DC	1	227.97 W
		2	244.19 W
Switch plus AT-XEM2-8XSTm Card	AC	1	226.71 W
		2	250.27 W
	DC	1	221.56 W
		2	237.91 W

Table 44 lists the maximum power consumptions for the AT-x950-28XTQm Switch.

Table 44. Maximum Power Consumptions (Watts) for the AT-x950-28XTQm Switch

AT-x950-28XTQm Switch and Line Card	PWR600	Number of Power Supplies	Maximum Power Consumption
Switch - No card	AC	1	234.55 W
		2	255.26 W
	DC	1	222.55 W
		2	238.80 W
Switch plus AT-XEM2-4QS Card	AC	1	253.19 W
		2	271.68 W
	DC	1	240.59 W
		2	256.15 W
Switch plus AT-XEM2-12XT Card	AC	1	280.51 W
		2	295.82 W
	DC	1	267.19 W
		2	281.79 W
Switch plus AT-XEM2-12XS Card	AC	1	269.62 W
		2	286.18 W
	DC	1	256.71 W
		2	271.49 W
Switch plus AT-XEM2-1CQ Card	AC	1	241.95 W
		2	261.74 W
	DC	1	230.07 W
		2	246.02 W

Table 44. Maximum Power Consumptions (Watts) for the AT-x950-28XTQm Switch (Continued)

AT-x950-28XTQm Switch and Line Card	PWR600	Number of Power Supplies	Maximum Power Consumption
Switch plus AT-XEM2-12XTm Card	AC	1	267.89 W
		2	284.63 W
	DC	1	254.83 W
		2	269.90 W
Switch plus AT-XEM2-12XS v2 Card	AC	1	261.97 W
		2	280.37 W
	DC	1	248.92 W
		2	264.26 W
Switch plus AT-XEM2-8XSTm Card	AC	1	255.31 W
		2	273.90 W
	DC	1	242.46 W
		2	258.15 W

Table 45 lists the maximum power consumptions for the AT-x950-52XSQ Switch.

Table 45. Maximum Power Consumptions (Watts) for the AT-x950-52XSQ Switch

	AT-PWR600	Number of Power Supplies	Maximum Power Consumption
AT-x950-52XSQ Switch	AC	1	246.26 W
		2	266.12 W
	DC	1	229.90 W
		2	247.40 W

Table 46 lists the maximum power consumptions for the AT-x950-52XTQm Switch.

Table 46. Maximum Power Consumptions (Watts) for the AT-x950-52XTQm Switch

	AT-PWR600	Number of Power Supplies	Maximum Power Consumption
AT-x950-52XTQm Switch	AC	1	274.04 W
		2	291.09 W
	DC	1	263.10 W
		2	273.30 W

Typical Power Savings in eco-friendly Mode

Table 47 lists the typical power savings in eco-friendly mode for the AT-x950-28XSQ Switch.

Table 47. Typical Power Savings in eco-friendly Mode (Watts) for the AT-x950-28XSQ Switch

AT-x950-28XSQ Switch and Line Card	Power Savings
Switch - No card	0.53 W
Switch plus AT-XEM2-4QS Card	0.64 W
Switch plus AT-XEM2-12XT Card	0.64 W
Switch plus AT-XEM2-12XS Card	0.66 W
Switch plus AT-XEM2-1CQ Card	0.55 W
Switch plus AT-XEM2-12XTm Card	0.64 W
Switch plus AT-XEM2-12XS v2 Card	0.84 W
Switch plus AT-XEM2-8XSTm Card	0.81 W

Table 48 lists the typical power savings in eco-friendly mode for the AT-x950-28XTQm Switch.

Table 48. Typical Power Savings in eco-friendly Mode (Watts) for the AT-x950-28XTQm Switch

AT-x950-28XTQm Switch and Line Card	Power Savings
Switch - No card	0.73 W
Switch plus AT-XEM2-4QS Card	0.84 W
Switch plus AT-XEM2-12XT Card	0.84 W
Switch plus AT-XEM2-12XS Card	0.86 W
Switch plus AT-XEM2-1CQ Card	0.75 W
Switch plus AT-XEM2-12XTm Card	0.84 W
Switch plus AT-XEM2-12XS v2 Card	0.84 W
Switch plus AT-XEM2-8XSTm Card	0.81 W

Input Voltage

Table 49 lists the input voltage for the power supply.

Table 49. Input Voltages

	AC	DC
AT-x950-28XSQ Switch	100-240 VAC~, 4A maximum, 50/60 Hz (per inputx2)	40-60V DC, 6.0A (per Input x2)
AT-x950-28XTQm Switch	100-240 VAC~, 4A maximum, 50/60 Hz (per inputx2)	40-60V DC, 6.0A (per Input x2)
AT-x950-52XSQ Switch	100-240 VAC~, 4A maximum, 50/60 Hz (per inputx2)	40-60V DC, 6.0A (per Input x2)
AT-x950-52XTQm Switch	100-240 VAC~, 4A maximum, 50/60 Hz (per inputx2)	40-60V DC, 6.0A (per Input x2)
AT-PWR600 AC	100-240 VAC~, 8.7A maximum, 50/60 Hz (per input)	N/A
AT-PWR600-80 DC	N/A	40-72 VDC, 6.0A maximum

Maximum Power Supply Efficiency

Table 50 lists the maximum power supply efficiency.

Table 50. Maximum Power Supply Efficiency (Based on 100V Input Voltage)

AT-PWR600 AC Power Supply	Up to 85%
---------------------------	-----------

Heat Dissipations

Table 51 lists the heat dissipations for the AT-x950-28XSQ Switch.

Table 51. Heat Dissipations for the AT-x950-28XSQ Switch

AT-x950-28XSQ Switch and Line Card	AT-PWR600	Number of Power Supplies	Heat Dissipation (British Thermal Units/Hour)
Switch - No card	AC	1	703.24 BTU/hr
		2	789.03 BTU/hr
	DC	1	688.80 BTU/hr
		2	746.16 BTU/hr

Table 51. Heat Dissipations for the AT-x950-28XSQ Switch (Continued)

AT-x950-28XSQ Switch and Line Card	AT-PWR600	Number of Power Supplies	Heat Dissipation (British Thermal Units/Hour)
Switch plus AT-XEM2-4QS Card	AC	1	766.27 BTU/hr
		2	846.43 BTU/hr
	DC	1	750.05 BTU/hr
		2	805.71 BTU/hr
Switch plus AT-XEM2-12XT Card	AC	1	856.77 BTU/hr
		2	927.68 BTU/hr
	DC	1	840.40 BTU/hr
		2	893.01 BTU/hr
Switch plus AT-XEM2-12XS Card	AC	1	820.36 BTU/hr
		2	895.09 BTU/hr
	DC	1	804.17 BTU/hr
		2	858.03 BTU/hr
Switch plus AT-XEM2-1CQ Card	AC	1	729.01 BTU/hr
		2	812.82 BTU/hr
	DC	1	714.43 BTU/hr
		2	771.36 BTU/hr
Switch plus AT-XEM2-12XTm Card	AC	1	818.86 BTU/hr
		2	892.84 BTU/hr
	DC	1	797.61 BTU/hr
		2	851.99 BTU/hr
Switch plus AT-XEM2-12XS v2 Card	AC	1	796.40 BTU/hr
		2	874.69 BTU/hr
	DC	1	777.95 BTU/hr
		2	833.31 BTU/hr

Table 51. Heat Dissipations for the AT-x950-28XSQ Switch (Continued)

AT-x950-28XSQ Switch and Line Card	AT-PWR600	Number of Power Supplies	Heat Dissipation (British Thermal Units/Hour)
Switch plus AT-XEM2-8XSTm Card	AC	1	773.64 BTU/hr
		2	854.04 BTU/hr
	DC	1	756.07 BTU/hr
		2	811.85 BTU/hr

Table 52 lists the heat dissipations for the AT-x950-28XTQm Switch.

Table 52. Heat Dissipations for the AT-x950-28XTQm Switch

AT-x950-28XTQm Switch and Line Card	AT-PWR600	Number of Power Supplies	Heat Dissipation (British Thermal Units/Hour)
Switch - No card	AC	1	800.40 BTU/hr
		2	871.07 BTU/hr
	DC	1	759.43 BTU/hr
		2	814.90 BTU/hr
Switch plus AT-XEM2-4QS Card	AC	1	864.01 BTU/hr
		2	927.10 BTU/hr
	DC	1	821.00 BTU/hr
		2	874.12 BTU/hr
Switch plus AT-XEM2-12XT Card	AC	1	957.23 BTU/hr
		2	1009.48 BTU/hr
	DC	1	911.79 BTU/hr
		2	961.62 BTU/hr
Switch plus AT-XEM2-12XS Card	AC	1	920.07 BTU/hr
		2	976.58 BTU/hr
	DC	1	876.02 BTU/hr
		2	926.45 BTU/hr

Table 52. Heat Dissipations for the AT-x950-28XTQm Switch (Continued)

AT-x950-28XTQm Switch and Line Card	AT-PWR 600	Number of Power Supplies	Heat Dissipation (British Thermal Units/Hour)
Switch plus AT-XEM2-1CQ Card	AC	1	825.65 BTU/hr
		2	893.18 BTU/hr
	DC	1	785.09 BTU/hr
		2	839.52 BTU/hr
Switch plus AT-XEM2-12XTm Card	AC	1	914.17 BTU/hr
		2	971.29 BTU/hr
	DC	1	869.62 BTU/hr
		2	921.01 BTU/hr
Switch plus AT-XEM2-12XS v2 Card	AC	1	893.97 BTU/hr
		2	956.76 BTU/hr
	DC	1	849.44 BTU/hr
		2	901.77 BTU/hr
Switch plus AT-XEM2-8XSTm Card	AC	1	871.24 BTU/hr
		2	934.68 BTU/hr
	DC	1	827.40 BTU/hr
		2	880.92 BTU/hr

Table 53 list the heat dissipations for the AT-x950-52XSQ Switch.

Table 53. Heat Dissipations for the AT-x950-52XSQ Switch

	AT-PWR6 00	Number of Power Supplies	Heat Dissipation (British Thermal Units/Hour)
AT-x950-52XSQ Switch	AC	1	840.36 BTU/hr
		2	908.13 BTU/hr
	DC	1	784.53 BTU/hr
		2	844.25 BTU/hr

Table 54 list the heat dissipations for the AT-x950-52XTQm Switch.

Table 54. Heat Dissipations for the AT-x950-52XTQm Switch

	AT-PWR6 00	Number of Power Supplies	Heat Dissipation (British Thermal Units/Hour)
AT-x950-52XTQm Switch	AC	1	935.16 BTU/hr
		2	993.34 BTU/hr
	DC	1	897.82 BTU/hr
		2	932.63 BTU/hr

Certifications

Table 55 lists the product certificates.

Table 55. Product Certifications

EMI (Emissions)	FCC Class A CISPR 22 Class A EN 55032 Class A VCCI Class A ICES-003 Class A RCM
EMC (Immunity)	EN 55035 EN 61000-3-2 EN 61000-3-3
Electrical and Laser Safety	UL 60950-1 (cULUS) EN 62368-1 (TUV) EN 60825-1 (TUV)
RoHS	RoHS6

RJ-45 Copper Port Pinouts

Figure 150 illustrates the pin layout of the RJ-45 copper connectors on the following products:

- ❑ AT-x950-28XTQm Switch
- ❑ AT-x950-52XTQm Switch
- ❑ AT-XEM2-8XSTm Line Card
- ❑ AT-XEM2-12XT Line Card
- ❑ AT-XEM2-12XTm Line Card

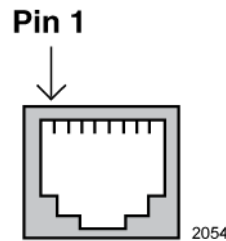


Figure 150. Pin Layout (Front View) of Copper Ports

Table 56 lists the pin signals at 100M.

Table 56. Pin Signals on RJ-45 Copper Ports at 100M

Pin	MDI Signal	MDI-X Signal
1	TX+	RX+
2	TX-	RX-
3	RX+	TX+
4	Not used	Not used
5	Not used	Not used
6	RX-	TX-
7	Not used	Not used
8	Not used	Not used

Table 57 lists the pin signals at 1G/2.5G/5G/10G.

Table 57. Pin Signals on Copper Ports at 1G/2.5G/5G/10G

Pin	Pair	Signal
1	1 +	TX and RX+
2	1 -	TX and RX-
3	2 +	TX and RX+
4	3 +	TX and RX+
5	3 -	TX and RX-
6	2 -	TX and RX-
7	4 +	TX and RX+
8	4 -	TX and RX-

RJ-45 Style Serial Console Port Pinouts

Table 58 lists the pin signals of the RJ-45 style serial Console port.

Table 58. RJ-45 Style Serial Console Port Pin Signals

Pin	Signal
1	Looped to pin 8.
2	Looped to pin 7.
3	Transmit Data
4	Ground
5	Ground
6	Receive Data
7	Looped to pin 2.
8	Looped to pin 1.

