

x950 Series Switches

Advanced Layer 3+
AlliedWare Plus™

Switches

x950-28XSQ	x950-28XTQm
x950-52XSQ	x950-52XTQm

Power Supplies

PWR600 AC	PWR600R AC
PWR600-80 DC	PWR600R-80 DC

Ethernet Line Cards

XEM2-8XSTm	
XEM2-12XT	XEM2-12XTm
XEM2-12XS	XEM2-12XS v2
XEM2-4QS	XEM2-1CQ

Fan Modules

FAN05	FAN05R
-------	--------

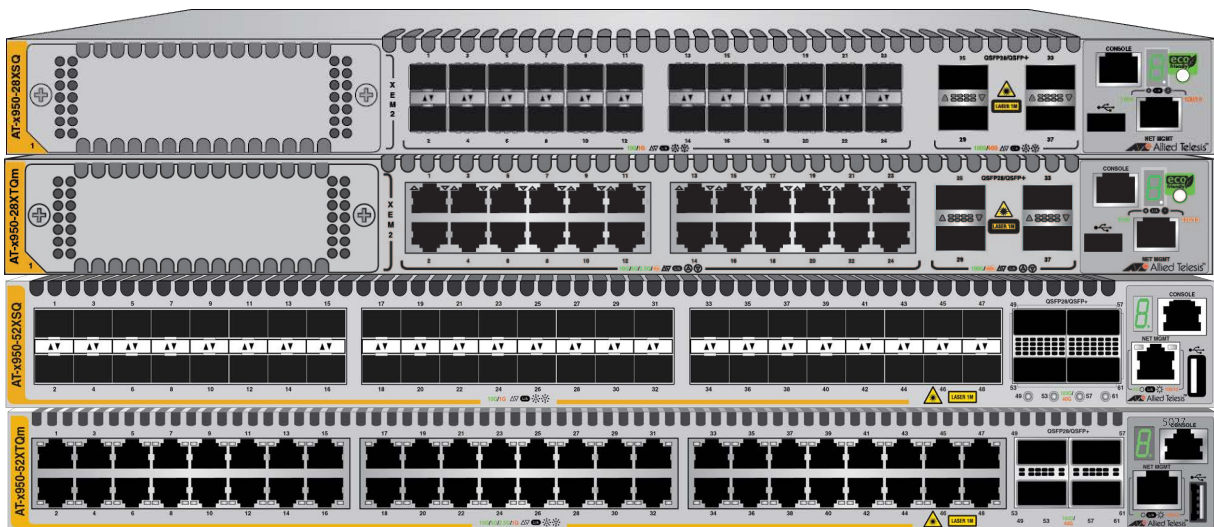

Installation Guide for Virtual Chassis Stacking

Copyright © 2025 Allied Telesis, Inc.

All rights reserved. No part of this publication may be reproduced without prior written permission from Allied Telesis, Inc.

Allied Telesis, VCStack, and the Allied Telesis logo are trademarks of Allied Telesis, Incorporated. All other product names, company names, logos or other designations mentioned herein are trademarks or registered trademarks of their respective owners.

Allied Telesis, Inc. reserves the right to make changes in specifications and other information contained in this document without prior written notice. The information provided herein is subject to change without notice. In no event shall Allied Telesis, Inc. be liable for any incidental, special, indirect, or consequential damages whatsoever, including but not limited to lost profits, arising out of or related to this manual or the information contained herein, even if Allied Telesis, Inc. has been advised of, known, or should have known, the possibility of such damages.

Electrical Safety and Emissions Standards

This product meets the following standards.

U.S. Federal Communications Commission
<p>Radiated Energy</p> <p>Note: This equipment has been tested and found to comply with the limits for a Class A digital device pursuant to Part 15 of FCC Rules. These limits are designed to provide reasonable protection against harmful interference when the equipment is operated in a commercial environment. This equipment generates, uses, and can radiate radio frequency energy and, if not installed and used in accordance with this instruction manual, may cause harmful interference to radio communications. Operation of this equipment in a residential area is likely to cause harmful interference in which case the user will be required to correct the interference at his own expense.</p> <p>Note: Modifications or changes not expressly approved of by the manufacturer or the FCC, can void your right to operate this equipment.</p>

Industry Canada
<p>This Class A digital apparatus complies with Canadian ICES-003.</p> <p>Cet appareil numérique de la classe A est conforme à la norme NMB-003 du Canada.</p>

Warning: In a domestic environment this product may cause radio interference in which case the user may be required to take adequate measures.

EMI (Emissions)	FCC Class A CISPR 22 Class A EN 55032 Class A VCCI Class A ICES-003 Class A RCM
EMC (Immunity)	EN 55024 EN 61000-3-2 EN 61000-3-3
Electrical Safety	UL 60950-1 (cUL _{US}) EN 62368-1 (TUV) EN 60825-1 (TUV)
Laser Safety	EN60825-1
RoHS	RoHS6

Power Supply Safety Compliance

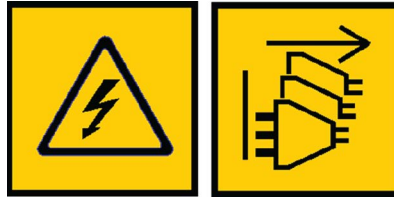

Warning

This unit has more than one power input. To reduce the risk of electric shock, disconnect all power inputs before servicing unit.

Avertissement

Cet appareil possède plusieurs entrées d'alimentation. Pour réduire le risque de choc électrique, débranchez toutes les entrées d'alimentation avant toute intervention sur l'appareil.

Contents

Preface	15
Document Conventions	16
Translated Safety Statements	17
Chapter 1: Overview	19
x950 Switches	20
Features	22
Hardware Features	22
XEM2 Ethernet Line Cards	23
Management Software and Interfaces	23
Management Methods	23
Management Panel	24
Power Supplies	24
1G SFP and 10G SFP+ Ports on the AT-x950-28XSQ and AT-x950-52XSQ Switches	25
LEDs	26
Copper Ports on the AT-x950-28XTQm and AT-x950-52XTQm Switches	27
Cable Requirements	27
LEDs	28
Ports for 40G QSFP+ and 100G QSFP28 Transceivers, and Breakout Cables	30
QSFP+ Transceivers	30
QSFP28 Transceivers	30
Breakout Cables	30
LEDs	31
Port Numbering for the AT-x950-28XSQ and AT-x950-28XTQm Switches	33
Port Numbering for the AT-x950-52XSQ and AT-x950-52XTQm Switches	34
Management Panel	35
USB Port	36
NET MGMT Ethernet Management Port	39
Console (RS-232) Port	40
Switch ID LED	40
eco-friendly Button	42
Direct Attach Cables	43
AT-PWR600 and AT-PWR600R AC and DC Power Supplies	44
Power Supply Guidelines	49
LEDs	49
AT-FAN05 and AT-FAN05R Fan Modules	52
Designating Ports in the Command Line Interface	54
Base Ports and XEM2 Line Card Ports	55
Examples for the PORT Parameter on Base Ports	55
Examples of the PORT Parameter for XEM2 Line Cards	56
Examples of the PORT Parameter for Breakout Cables	56
Software and Hardware Releases	59
Chapter 2: XEM2 Ethernet Line Cards	61
Overview	62
AT-XEM2-8XSTm Line Card	65
Copper Ports	65
Copper Port LEDs	66
Transceiver Ports	67
Transceiver Port LEDs	68

AT-XEM2-12XT Line Card	69
Copper Ports	69
LEDs	70
AT-XEM2-12XTm Line Card	71
Copper Ports	71
LEDs	72
AT-XEM2-12XS and AT-XEM2-12XS v2 Line Cards	73
Transceiver Ports	73
Card Versions	74
LEDs	74
AT-XEM2-4QS Line Card	76
Transceiver Ports	76
LEDs	77
AT-XEM2-1CQ Line Card	78
Transceiver Port	78
LEDs	79
Chapter 3: Virtual Chassis Stacking	81
Overview	82
Stacking Guidelines	83
Stack Trunks	84
Ports 1 to 24 and Ports 1 to 48	84
Ports 25 to 37 and Ports 49 to 61 with 40G Transceivers	90
Ports 25 to 37 and Ports 49 to 61 with 100G Transceivers	91
XEM2 Line Cards	93
Unsupported Trunks	95
Master and Member Switches	100
Selection of the Master Switch	100
Switch ID Numbers	101
Optional Feature Licenses	102
Planning a Stack	103
Stacking Worksheet	104
Chapter 4: Beginning the Installation	109
Reviewing Safety Precautions	110
Installation Options	115
Choosing a Site for the Chassis	116
Unpacking the Switch	117
Verifying the Accessory Kit	121
Unpacking PWR600 AC and DC Power Supplies	123
Chapter 5: Installing Power Supplies and XEM2 Line Cards	127
Installing AT-PWR600 and AT-PWR600R AC Power Supplies	128
Installing AT-PWR600-80 and AT-PWR600R-80 DC Power Supplies	132
Installing the Power Supply	133
Connecting the Grounding Wire	134
Connecting the DC Power Wires	137
Installing XEM2 Ethernet Line Cards	141
Chapter 6: Installing the Switch on a Table	145
Chapter 7: Installing the Switch in an Equipment Rack	149
Beginning the Installation	150
Required Items	150
Switch Orientations in the Equipment Rack	150
Removing the Bumper Feet	152
Installing the Switch	153
Chapter 8: Installing the Switch on a Wall	157
Switch Orientations on a Wall	158
Recommended Minimum Wall Area Dimensions	159
Plywood Base for a Wall with Wooden Studs	161
Installation Guidelines	163

Tools and Material	164
Installing the Plywood Base	165
Installing the Switch on the Plywood Base	166
Installing the Switch on a Concrete Wall	169
Chapter 9: Installing the Switch in the RKMT-SL01 Sliding Rack	173
Introduction	174
Rack Mount Kit Components	175
Adjustable Outer Rails	175
Inner Rails	175
Extension Brackets	175
Equipment Rack Requirements	177
Reviewing Safety Precautions	178
Installation Overview	180
Unpacking the Shipping Container	181
Installing the Outer Rails on the Equipment Rack	183
Installing the Extension Brackets on the Inner Rails	185
Measuring the Extension Bracket Lengths	185
Assembling the Extension Brackets	187
Installing the Inner Rails on the Switch	191
Installing the Switch in the Equipment Rack	193
Chapter 10: Configuring the Master Switch	197
Command Summary	198
PLATFORM PORTMODE INTERFACE	198
STACKPORT	199
STACK ENABLE	200
STACK PRIORITY	200
STACK RENUMBER	201
SWITCH PROVISION	201
Powering On a Switch	202
Powering on PWR600 AC Power Supplies	202
Powering on PWR600-80 DC Power Supplies	204
Starting a Local Management Session	206
General Steps for the Master Switch	208
Configuring the Master Switch - Part I	210
Configuring the Master Switch - Part II	213
Verifying the Master Switch	216
What to Do Next	218
Chapter 11: Configuring Member Switches	219
General Steps for Member Switches	220
Configuring a Member Switch - Part I	222
Configuring a Member Switch - Part II	225
Verifying a Member Switch	227
What to Do Next	229
Chapter 12: Powering On and Verifying the Stack	231
Powering on the Stack	232
Verifying the Stack	233
Chapter 13: Cabling the Networking Ports	235
Cabling Copper Ports	236
Guidelines to Handling Copper or Fiber Optic Transceivers	237
Installing Transceivers	238
Installing Direct Attach Cables	244
Chapter 14: Replacing Modules	247
Replacing XEM2 Line Cards	248
Replacing PWR600 and AT-PWR600R AC Power Supplies	253
Replacing AT-PWR600-80 and AT-PWR600R-80 DC Power Supplies	258
Replacing FAN05 Modules	261

Removing Fan Modules.....	261
Installing Fan Modules.....	263
Chapter 15: Troubleshooting	267
Appendix A: Technical Specifications	273
Physical Specifications	274
Environmental Specifications.....	278
Power Specifications.....	279
Certifications	289
RJ-45 Twisted Pair Port Pinouts	290
RJ-45 Style Serial Console Port Pinouts	292

Figures

Figure 1: Front Panels of the AT-x950-28XSQ and AT-x950-28XTQm Switches	20
Figure 2: Front Panels of the AT-x950-52XSQ and AT-x950-52XTQm Switches	21
Figure 3: Rear Panel of the x950 Series.....	21
Figure 4: Link and Activity LEDs for 1G SFP and 10G SFP+ Ports	26
Figure 5: Link and Activity LEDs for the Copper Ports on the AT-x950-28XTQm and AT-x950-52XTQm Switches.....	28
Figure 6: AT-QSFP-4SFP10G-3CU and AT-QSFP-4SFP10G-5CU Copper Breakout Cables	31
Figure 7: LEDs for Ports 25, 29, 33, and 37 on the AT-x950-28XSQ and AT-x950-28XTQm Switches	31
Figure 8: LEDs for Ports 49, 53, 57, and 61 on the AT-x950-52XSQ and AT-x950-52XTQm Switches	31
Figure 9: Management Panel on the AT-x950-28XSQ and AT-x950-28XTQm Switches	35
Figure 10: Management Panel on the AT-x950-52XSQ and AT-x950-52XTQm Switches	35
Figure 11: Switch ID LED with the eco-friendly Mode Disabled	41
Figure 12: Switch ID LED with the eco-friendly Mode Enabled	41
Figure 13: AT-PWR600 Power Supply and AT-FAN05 Fan Module	45
Figure 14: AT-PWR600R AC Power Supply and AT-FAN05R Fan Module	46
Figure 15: AT-PWR600-80 DC Power Supply and AT-FAN05 Fan Module.....	47
Figure 16: AT-PWR600R-80 DC Power Supply and AT-FAN05R Fan Module.....	48
Figure 17: AT-FAN05 and AT-FAN05R Fan Modules	52
Figure 18: PORT Parameter in the Command Line Interface for VCStack	54
Figure 19: Slot Numbers for Port Numbering on AT-x950-28XSQ and AT-x950-28XTQm Switches	55
Figure 20: Copper Breakout Cable	56
Figure 21: XEM2 Ethernet Line Cards.....	62
Figure 22: AT-XEM2-8XSTm Line Card	65
Figure 23: AT-XEM2-12XT Line Card.....	69
Figure 24: AT-XEM2-12XTm Line Card.....	71
Figure 25: AT-XEM2-12XS Line Card	73
Figure 26: AT-XEM2-12XS and AT-XEM2-12XS v2 Line Cards	74
Figure 27: AT-XEM2-4QS Line Card	76
Figure 28: AT-XEM2-1CQ Line Card.....	78
Figure 29: Example Stacks of AT-x950-28XSQ Switches with Trunks of 10G Ports	86
Figure 30: Example Stacks of AT-x950-28XTQm Switches with Trunks of 10G Ports.....	87
Figure 31: Example Stack Trunks of 10G Links on AT-x950-28XSQ and AT-x950-52XSQ Switches	88
Figure 32: Example Stack Trunks of 10G Links on AT-x950-28XTQm and AT-x950-52XTQm Switches.....	89
Figure 33: Stack Trunk Examples of Two Switches with Trunk 40G Links.....	90
Figure 34: Stack Trunk Examples of Three or Four Switches with 40G Links.....	91
Figure 35: Stack Trunk Examples with 100G Links	92
Figure 36: Example Trunk Using AT-XEM2-12XT Line Cards	94
Figure 37: Example Trunk Using AT-XEM2-12XS Line Cards	94
Figure 38: Example Trunk Using AT-XEM2-4QS Line Cards.....	95
Figure 39: Unsupported Trunk with Different Numbers of Links Between Switches	95
Figure 40: Unsupported Trunk with Mixed Cables.....	96
Figure 41: Unsupported Trunk with Both Base and XEM2 Line Card Ports.....	96
Figure 42: Unsupported Trunk of Connected Base and Line Card Ports	96
Figure 43: Unsupported Trunk with Only One Link Between Switches	97
Figure 44: Unsupported Trunk with Different Port Speeds	97
Figure 45: Not Recommended Stack Trunk of AT-XEM2-1CQ Line Cards.....	98
Figure 46: Unsupported Trunk with a 10G Breakout Cable.....	98
Figure 47: Unsupported Trunk with Intermediary Network Devices	99
Figure 48: Installation Options	115
Figure 49: Removing Accessories	117

Figure 50: Removing the Shipping Partition	118
Figure 51: Lifting the Switch from the Shipping Box	119
Figure 52: Removing the Switch from the Shipping End-caps and Protective Bag	119
Figure 53: Removing the Power Cord and Documents from the Power Supply Shipping Box	123
Figure 54: Removing the Partition from the Power Supply Shipping Box	124
Figure 55: Removing the Power Supply from the Shipping Box	125
Figure 56: Removing the Power Supply from the Shipping End-caps and Protective Bag	125
Figure 57: Removing the Blank Power Supply Panel from Slot PSU B	129
Figure 58: Sliding the AT-PWR600 or AT-PWR600R AC Power Supply into the Chassis	130
Figure 59: Seating the Power Supply on the Internal Connector	131
Figure 60: Sliding the PWR600-80 DC Power Supply into the Chassis	133
Figure 61: Stripping the Grounding Wire	134
Figure 62: Loosening the Screw for the Panel	135
Figure 63: Accessing the Connectors	135
Figure 64: Loosening the Ground Screw	136
Figure 65: Wrapping the Grounding Wire and Tightening the Screw	136
Figure 66: Stripping the Power Wire	137
Figure 67: Wrapping the Wire Strands	137
Figure 68: Loosening the Screw for the Negative (-)	138
Figure 69: Tightening the Screw for the Negative (-)	138
Figure 70: Loosening the Screw for the Negative (+)	139
Figure 71: Tightening the Screw for the Negative (+)	139
Figure 72: Placing the Cover Panel	140
Figure 73: Tightening the Screw for the Cover Panel	140
Figure 74: Removing the Blank Line Card Cover	141
Figure 75: Removing the XEM2 Line Card from the Anti-static Bag	142
Figure 76: Sliding the XEM2 Line Card into the Slot	142
Figure 77: Seating the XEM2 Line Card in the Expansion Slot	143
Figure 78: Tightening the Two Captive Screws on the XEM2 Line Card	144
Figure 79: Parts of the Bumper Feet	145
Figure 80: Holes for Bumper Feet	146
Figure 81: Inserting the Rivet Housing into the Bumper Foot	146
Figure 82: Placing the Bumper Foot on a Base Corner Hole	147
Figure 83: Inserting the Rivet into the Bumper Foot	147
Figure 84: Holes for the Equipment Rack Brackets on the x950-28XSQ and x950-28XTQm Switches	150
Figure 85: Holes for the Equipment Rack Brackets on the x950-52XSQ and x950-52XTQm Switches	150
Figure 86: Switch Orientations in an Equipment Rack	151
Figure 87: Removing the Bumper Feet	152
Figure 88: Attaching the Equipment Rack Brackets	154
Figure 89: Installing the Switch in an Equipment Rack	154
Figure 90: Positions of the Switch on the Wall	158
Figure 91: Minimum Wall Area Dimensions with the Front Panel on the Left	159
Figure 92: Minimum Wall Area Dimensions with the Front Panel on the Right	160
Figure 93: Switch on the Wall with a Plywood Base	161
Figure 94: Steps to Installing the Switch with a Plywood Base	162
Figure 95: Installing the Brackets to the Switch for Wall Installation	166
Figure 96: Attaching the Switch to the Plywood Base	167
Figure 97: Marking the Locations of the Bracket Holes on a Concrete Wall	170
Figure 98: Installing the Switch on a Concrete Wall	171
Figure 99: Outer Rails	175
Figure 100: Inner Rails	175
Figure 101: Extension Brackets	176
Figure 102: Shipping Container Contents	181
Figure 103: FRONT and REAR Labels on the Outer Rails	183
Figure 104: Installing the Outer Rails on the Equipment Rack	184
Figure 105: Extension Brackets	185
Figure 106: Example of a Switch Recessed in an Equipment Rack	185
Figure 107: Inserting an Inner Rail into an Outer Rail	186
Figure 108: Example of Positioning the Inner Rail	186
Figure 109: Measuring for the Extension Brackets	186

Figure 110: Removing the Inner Rail	187
Figure 111: Extension Bracket Parts	187
Figure 112: Extension Bracket Configurations	188
Figure 113: Example of Attaching the Extension Brackets to the Inner Rails.....	189
Figure 114: Testing the Inner Rails with the Extension Brackets	190
Figure 115: Verifying the Length of the Extension Bracket.....	190
Figure 116: Inner Rail Screw Holes on the AT-x950-28XSQ and AT-x950-28XTQm Switches	191
Figure 117: Inner Rail Screw Holes on the AT-x950-52XSQ and AT-x950-52XTQm Switches	191
Figure 118: Attaching the Inner Rails to the x950 Switch.....	192
Figure 119: Sliding the Inner Rails on the Switch into the Outer Rails	193
Figure 120: Affixing the Warning Labels.....	194
Figure 121: Tightening the Two Screws on the Fixed Brackets	194
Figure 122: Tightening the Screws on the Outer Rails.....	195
Figure 123: Connecting the AC Power Cord	203
Figure 124: Securing the AC Power Cord with the Restraining Strap	203
Figure 125: Connecting the Power Cord to an AC Power Source.....	204
Figure 126: Connecting the Management Cable to the Console RS-232 Port.....	206
Figure 127: User Exec Mode Prompt	207
Figure 128: Powering Off the AT-PWR600 or AT-PWR600R AC Power Supply	218
Figure 129: SHOW STACK Command.....	233
Figure 130: Handle on 100G Transceivers for XEM2-1CQ Line Cards.....	237
Figure 131: SP10T Transceivers	239
Figure 132: Installing an SFP or SFP+ Transceiver	241
Figure 133: Installing 40G Fiber Optic Transceivers in AT-XEM2-4QS Line Cards	242
Figure 134: Installing 100G QSFP28 Transceivers in Base Ports 25, 29, 33, 37.....	242
Figure 135: Installing 100G QSFP28 Transceivers in XEM2-1CQ Line Cards.....	243
Figure 136: Installing SP10TW Direct Attach Cables	244
Figure 137: Attaching QSFP28 Cables	245
Figure 138: Loosening the Screws on the Ethernet Line Card	249
Figure 139: Disconnecting the XEM2 Line Card from the Switch.....	250
Figure 140: Sliding the XEM2 Line Card from the Switch.....	250
Figure 141: Placing the XEM2 Line Card in its Anti-static Bag.....	251
Figure 142: Installing the Line Card Blank Cover	251
Figure 143: Tightening the Two Screws on the Line Card Blank Panel	252
Figure 144: Disconnecting the AC Power Cord from the Power Source	253
Figure 145: Opening the Restraining Strap on the PWR600 Power Supply.....	254
Figure 146: Disconnecting the Power Cord from the PWR600 Power Supply	254
Figure 147: Removing the PWR600 Power Supply.....	255
Figure 148: Removing the PWR600 Power Supply.....	256
Figure 149: Installing the Blank Power Supply Cover.....	257
Figure 150: Loosening the Screw for the Panel.....	258
Figure 151: Accessing the Connecting Screws	259
Figure 152: Front Panel of the PWR600 DC Power Supply	259
Figure 153: Removing the PWR600 DC Power Supply.....	260
Figure 154: Loosening the Screws on the Fan Module	261
Figure 155: Disconnecting the FAN05 Module from the Switch	262
Figure 156: Sliding the Fan Module from the Switch	262
Figure 157: Removing the Fan Module from the Shipping Container.....	263
Figure 158: Aligning the FAN05 Module in the Switch Slot.....	264
Figure 159: Seating the FAN05 Module on the Internal Connector.....	264
Figure 160: Tightening the Two Captive Screws on the FAN05 Module	265
Figure 161: Switch Width and Height	274
Figure 162: Switch Depth and Locations of Bracket Holes for the AT-x950-28XSQ and AT-x950-52XTQm Switches	275
Figure 163: Switch Depth and Bracket Holes for x950-52XSQ and x950-52XTQm Switches	276
Figure 164: Pin Layout (Front View) of Twisted Pair Ports.....	290

Tables

Table 1: x950 Switch Components	20
Table 2: Link and Activity Status LEDs for 1G SFP and 10G SFP+ Ports	26
Table 3: Copper Ports on AT-x950-28XTQm and AT-x950-52XTQm Switches	27
Table 4: Link and Activity LEDs for Copper Ports on AT-x950-28XTQm and AT-x950-52XTQm Switches	28
Table 5: Ports for QSFP+ and QSFP28 Transceivers, and 4x10G Breakout Cables	30
Table 6: Link and Activity Status LEDs for 40G QSFP+ and 100G QSFP28 Transceivers	32
Table 7: Link and Activity Status LEDs for 10G Breakout Cables	32
Table 8: Port Numbering for Ports 25 to 37	33
Table 9: Port Numbering for Ports 49, 53, 57, and 61	34
Table 10: Examples of Switch Features that Support the USB Port	36
Table 11: NET MGMT Port LED	40
Table 12: Optional Direct Attach Cables	43
Table 13: AT-PWR600 and AT-PWR600R AC and DC Power Supplies	44
Table 14: LEDs on the AT-PWR600 and AT-PWR600R AC Power Supplies	49
Table 15: LEDs on the AT-PWR600-80 and AT-PWR600R-80 DC Power Supplies	50
Table 16: Fan Modules and Power Supplies	52
Table 17: PORT Parameter Format for a Standalone Switch	54
Table 18: Port Numbers with and without Breakout Cables on the AT-x950-28XTQm and AT-x950-28XSQ Switches	56
Table 19: Port Numbers with and without Breakout Cables on the AT-x950-52XTQm and AT-x950-52XSQ Switches	57
Table 20: Port Numbers with and without Breakout Cables on the AT-XEM2-4QS Line Card	57
Table 21: Software and Hardware Releases	59
Table 22: XEM2 Ethernet Line Cards	63
Table 23: Copper Ports on the AT-XEM2-8XSTm Line Card	65
Table 24: Link and Activity LEDs for the Copper Ports on the AT-XEM2-8XSTm Line Card	66
Table 25: Link and Activity LEDs for the SFP Ports on the AT-XEM2-8XSTm Line Card	68
Table 26: Copper Ports on the AT-XEM2-12XT Line Card	69
Table 27: Port Link and Activity LEDs on the AT-XEM2-12XT Line Card	70
Table 28: Copper Ports on the AT-XEM2-12XTm Line Card	71
Table 29: Link and Activity LEDs on the AT-XEM2-12XTm Line Card	72
Table 30: Port Link and Activity LEDs on the AT-XEM2-12XS Line Card	74
Table 31: Port Link and Activity Status LEDs on the AT-XEM2-4QS Line Card	77
Table 32: Link and Activity Status LEDs for 10G Breakout Cables	77
Table 33: Port Link and Activity Status LED on the AT-XEM2-1CQ Line Card	79
Table 34: Maximum Number of Trunk Ports Per Switch	93
Table 35: Stacking Worksheet	104
Table 36: Stacking Worksheet Columns	105
Table 37: Example of a Completed Stack Worksheet	107
Table 38: Accessory Kit	121
Table 39: Additional Accessory Kit for the AT-x950-52XSQ and AT-x950-52XTQm Switches	122
Table 40: Extension Bracket Parts	187
Table 41: Configuring the Master Switch - Part I	210
Table 42: Configuring the Master Switch - Part II	213
Table 43: Verifying the Master Switch	216
Table 44: Configuring a Member Switch - Part I	222
Table 45: Configuring a Member Switch - Part II	225
Table 46: Verifying a Member Switch	227
Table 47: Transceivers for the Base Transceiver Slots	238
Table 48: Transceivers for XEM2 Ethernet Line Cards	239
Table 49: Product Dimensions	274

Tables

Table 50: Product Weights	277
Table 51: Ventilation Requirements	277
Table 52: Environmental Specifications	278
Table 53: Maximum Power Consumptions (Watts) for the AT-x950-28XSQ Switch	279
Table 54: Maximum Power Consumptions (Watts) for the AT-x950-28XTQm Switch	281
Table 55: Maximum Power Consumptions (Watts) for the AT-x950-52XSQ Switch	282
Table 56: Maximum Power Consumptions (Watts) for the AT-x950-52XTQm Switch	283
Table 57: Typical Power Savings in eco-friendly Mode (Watts) for the AT-x950-28XSQ Switch	283
Table 58: Typical Power Savings in eco-friendly Mode (Watts) for the AT-x950-28XTQm Switch	284
Table 59: Input Voltages	284
Table 60: Maximum Power Supply Efficiency (Based on 100V Input Voltage)	285
Table 61: Heat Dissipations for the AT-x950-28XSQ Switch	285
Table 62: Heat Dissipations for the AT-x950-28XTQm Switch	287
Table 63: Heat Dissipations for the AT-x950-52XSQ Switch	288
Table 64: Heat Dissipations for the AT-x950-52XTQm Switch	288
Table 65: Product Certifications	289
Table 66: Pin Signals on RJ-45 Twisted Pair Ports at 100M	290
Table 67: Pin Signals on Twisted Pair Ports at 1G/2.5G/5G/10G	291
Table 68: RJ-45 Style Serial Console Port Pin Signals	292

Preface

This guide contains the installation instructions for the x950 Series of advanced Layer 3+ Ethernet switches. The instructions explain how to build a virtual stack of up to four switches with the Virtual Chassis Stacking (VCStack) feature. For instructions on how to install the switches as standalone devices, refer to the *x950 Series Installation Guide for Standalone Switches*.

This preface contains the following sections:

- “Document Conventions” on page 16
- “Translated Safety Statements” on page 17

Document Conventions

This document uses the following conventions:

Note

Notes provide additional information.



Caution

Cautions inform you that performing or omitting a specific action may result in equipment damage or loss of data.



Warning

Warnings inform you that performing or omitting a specific action may result in bodily injury.



Warning

Laser warnings inform you that an eye or skin hazard exists due to the presence of a Class 1 laser device.

Translated Safety Statements

Important: Safety statements with the  symbol are translated into multiple languages in **Translated Safety Statements** at alliedtelesis.com/library/search.

Übersetzte Sicherheitshinweise:

Wichtig: Sicherheitshinweise mit dem -Symbol werden in **Translated Safety Statements** bei alliedtelesis.com/library/search in mehrere Sprachen übersetzt.

Declaraciones de seguridad traducidas;

Importante: Las declaraciones de seguridad con el símbolo  se traducen a varios idiomas en **Translated Safety Statements** en alliedtelesis.com/library/search.

Consignes de sécurité traduites:

Important: Les déclarations de sécurité avec le symbole  sont traduites en plusieurs langues en **Translated Safety Statements** sur alliedtelesis.com/library/search.

Dichiarazioni di sicurezza tradotte:

Importante: Le dichiarazioni di sicurezza con il simbolo  sono tradotte in più lingue in **Translated Safety Statements** su alliedtelesis.com/library/search.

Översatta säkerhetsförklaringar:

Viktig: Säkerhetsföreskrifter med -symbolen översätts till flera språk på **Translated Safety Statements** vid alliedtelesis.com/library/search.

Chapter 1

Overview

The chapter contains the following sections:

- ❑ “x950 Switches” on page 20
- ❑ “Features” on page 22
- ❑ “1G SFP and 10G SFP+ Ports on the AT-x950-28XSQ and AT-x950-52XSQ Switches” on page 25
- ❑ “Copper Ports on the AT-x950-28XTQm and AT-x950-52XTQm Switches” on page 27
- ❑ “Ports for 40G QSFP+ and 100G QSFP28 Transceivers, and Breakout Cables” on page 30
- ❑ “Management Panel” on page 35
- ❑ “Direct Attach Cables” on page 43
- ❑ “AT-PWR600 and AT-PWR600R AC and DC Power Supplies” on page 44
- ❑ “AT-FAN05 and AT-FAN05R Fan Modules” on page 52
- ❑ “Designating Ports in the Command Line Interface” on page 54
- ❑ “Software and Hardware Releases” on page 59

x950 Switches

Table 1 lists the hardware components for the x950 Switches.

Table 1. x950 Switch Components

Model	SFP/SFP+ Ports	1M/1G/2.5G/5G/10G Copper Ports	QSFP+/QSFP28 Ports for 40G/100G Transceivers and 10G Breakout Cables	XEM2 Line Card	eco-friendly Button
AT-x950-28XSQ	1 to 24	N/A	25, 29, 33, 37	Supported	Supported
AT-x950-28XTQm	N/A	1 to 24	25, 29, 33, 37	Supported	Supported
AT-x950-52XSQ	1 to 48	N/A	49, 53, 57, 61	N/A	N/A
AT-x950-52XTQm	N/A	1 to 48	49, 53, 57, 61	N/A	N/A

Figure 1 shows the front panels of the AT-x950-28XSQ and AT-x950-28XTQm Switches.

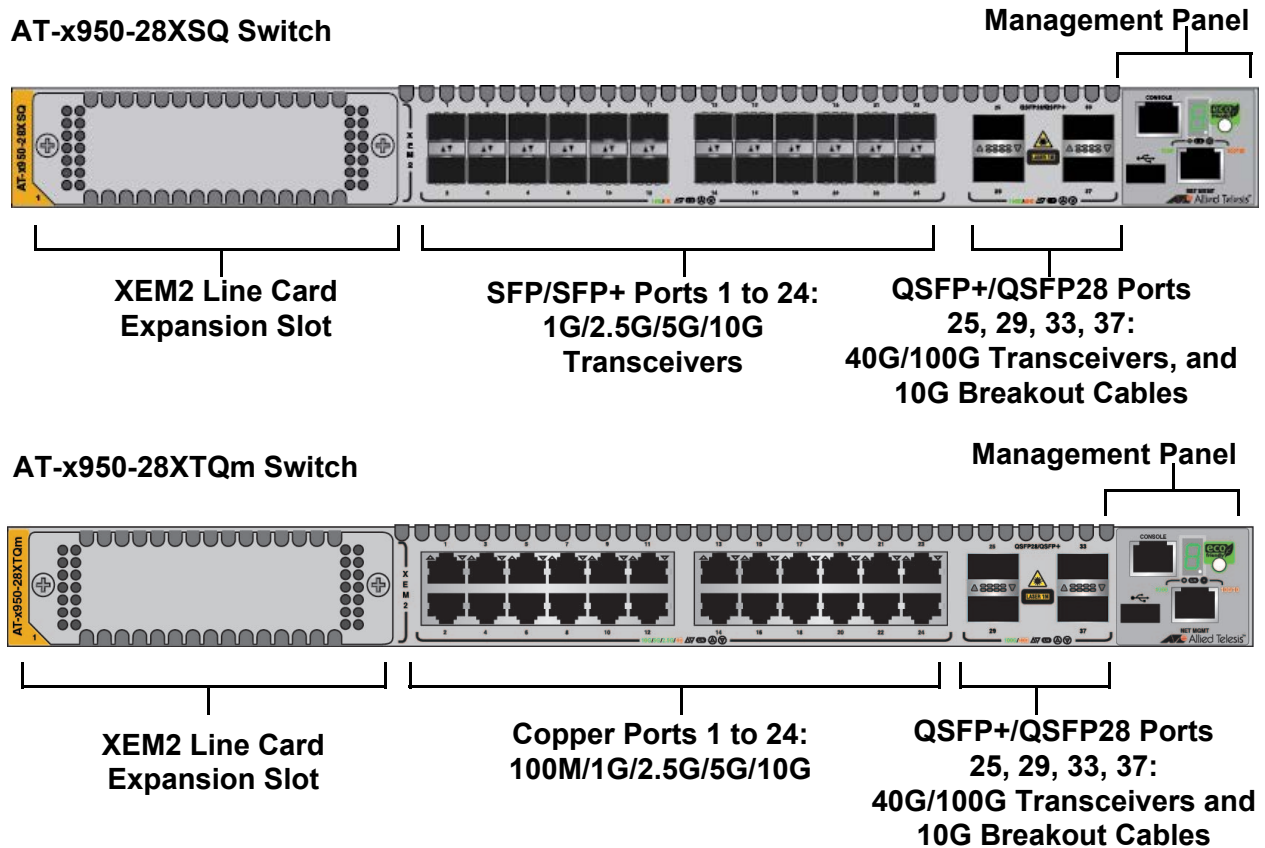
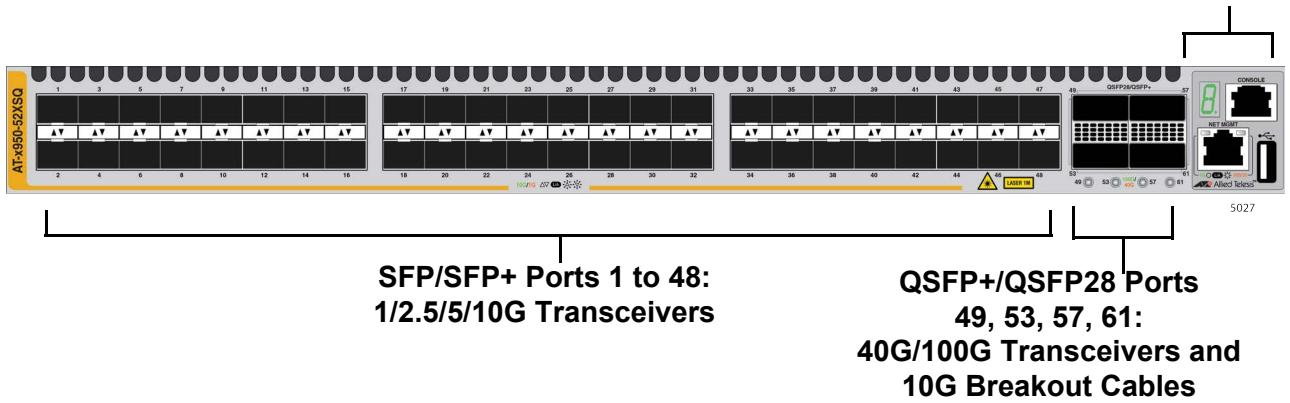

Figure 1. Front Panels of the AT-x950-28XSQ and AT-x950-28XTQm Switches

Figure 2 shows the front panels of the AT-x950-52XSQ and AT-x950-52XTQm Switches.

AT-x950-52XSQ Switch



AT-x950-52XTQm Switch

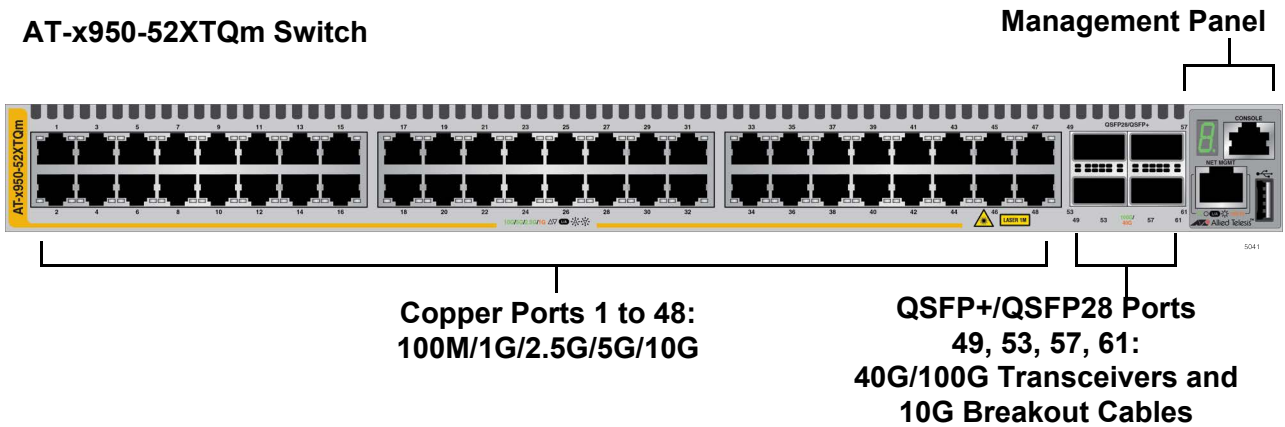

Figure 2. Front Panels of the AT-x950-52XSQ and AT-x950-52XTQm Switches

The rear panel of x950 Switches is shown in Figure 3.

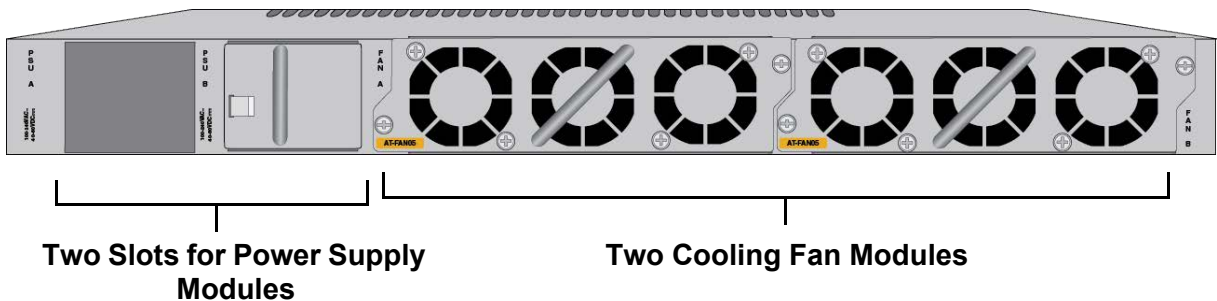

Figure 3. Rear Panel of the x950 Series

Features

The main hardware features of the x950 Switches are listed here.

Hardware Features

The switch has the following hardware features:

- ❑ 1RU height
- ❑ 24 ports on the AT-x950-28XSQ Switch for 1G/2.5G/5G/10G SFP/SFP+ transceivers. Refer to “1G SFP and 10G SFP+ Ports on the AT-x950-28XSQ and AT-x950-52XSQ Switches” on page 25.
- ❑ 24 copper ports on the AT-x950-28XTQm Switch with speeds of 100M/1G/2.5G/5G/10G. Refer to “Copper Ports on the AT-x950-28XTQm and AT-x950-52XTQm Switches” on page 27.
- ❑ 48 ports on the AT-x950-52XSQ Switch for 1G/2.5G/5G/10G SFP/SFP+ transceivers. Refer to “1G SFP and 10G SFP+ Ports on the AT-x950-28XSQ and AT-x950-52XSQ Switches” on page 25.
- ❑ 48 copper ports on the AT-x950-52XTQm Switch with speeds of 100M/1G/2.5G/5G/10G. Refer to “Copper Ports on the AT-x950-28XTQm and AT-x950-52XTQm Switches” on page 27.
- ❑ Four ports for 40G QSFP+ or 100G QSFP28 transceivers, or 10G breakout cables. Refer to “Ports for 40G QSFP+ and 100G QSFP28 Transceivers, and Breakout Cables” on page 30.
- ❑ One expansion slot on the AT-x950-28XSQ and AT-x950-28XTQm Switches for an optional XEM2 Line Card. Refer to Chapter 2, “XEM2 Ethernet Line Cards” on page 61.
- ❑ The switches support two power supplies for primary and redundant power. Refer to “AT-PWR600 and AT-PWR600R AC and DC Power Supplies” on page 44.
- ❑ The units come with two pre-installed fan modules. Refer to “AT-FAN05 and AT-FAN05R Fan Modules” on page 52.
- ❑ The switches come with brackets for standard 19-inch equipment racks or wall installation.
- ❑ The XEM2 Line Cards, power supplies, and fan modules are hot-swappable.

XEM2 Ethernet Line Cards

The XEM2 Line Cards for the AT-x950-28XSQ and AT-x950-28XTQm Switches are listed here:

- ❑ AT-XEM2-8XSTm Card features four 100M/1G/2.5G/5G/10G copper ports with RJ-45 connectors and four ports for 1G SFP or 10G SFP+ transceivers. Refer to “AT-XEM2-8XSTm Line Card” on page 65.
- ❑ AT-XEM2-12XT Card features 12 copper ports with speeds of 100M/ 1G/10G, and RJ-45 connectors. Refer to “AT-XEM2-12XT Line Card” on page 69.
- ❑ AT-XEM2-12XTm Card features 12 copper ports with speeds of 1G/2.5G/5G/10G, and RJ-45 connectors. Refer to “AT-XEM2-12XTm Line Card” on page 71.
- ❑ AT-XEM2-12XS and AT-XEM2-12XS v2 Cards feature 12 ports for 1G/10G SFP/SFP+ transceivers. Refer to “AT-XEM2-12XS and AT-XEM2-12XS v2 Line Cards” on page 73.
- ❑ AT-XEM2-4QS Card features four ports for 40G QSFP+ transceivers. Refer to “AT-XEM2-4QS Line Card” on page 76.
- ❑ AT-XEM2-1CQ Card features one port for an 100G QSFP28 transceiver. Refer to “AT-XEM2-1CQ Line Card” on page 78.

Line cards are ordered separately. Refer to the product data sheet on the Allied Telesis web site for a list of approved transceivers.

Management Software and Interfaces

Here are the management software and interfaces:

- ❑ AlliedWare Plus management software.
- ❑ Command line interface, available locally through the Console port or remotely over the network.

The AlliedWare Plus management software comes pre-installed on the switch.

Management Methods

You can manage the switch as follows:

- ❑ Command line interface accessed locally through the Console port or remotely using Telnet or Secure Shell.
- ❑ Remote access with SNMPv1, v2c, or v3.

Management Panel

The management panel has the following features:

- ❑ Console RS-232 port for local management (no IP address required).
- ❑ USB 2.0 port for storing backup copies of system configuration files, updating management software, and other management functions.
- ❑ An eco-friendly button for turning off the port and system LEDs to reduce power consumption.

Note

The AT-x950-52XSQ and AT-x950-52XTQm Switches do not have the eco-friendly button; however, the eco-friendly mode can be turned on or off with the ECOFRIENDLY LED or NO ECOFRIENDLY LED command in the Command Line Interface.

- ❑ Network management port for initial configuration and maintenance access to the chassis.

Power Supplies

The switch has slots for two power supplies on the back panel. The switch can be powered by a single power supply. Adding a second power supply provides power redundancy. Power supplies are ordered separately. Refer to “AT-PWR600 and AT-PWR600R AC and DC Power Supplies” on page 44.

1G SFP and 10G SFP+ Ports on the AT-x950-28XSQ and AT-x950-52XSQ Switches

Ports 1 to 24 on the AT-x950-28XSQ Switch and ports 1 to 48 on the AT-x950-52XSQ Switch support 1G SFP and 10G SFP+ transceivers. Here are examples of 1G SFP transceivers:

- ❑ SPSX and LR short and long distance transceivers using multi-mode or single mode fiber optic cable.
- ❑ SPTX transceiver series with RJ-45 connector for copper cable.
- ❑ SPEX transceivers with a maximum distance of two kilometers with multi-mode fiber optic cable.

Here are examples of SFP+ 10G transceivers:

- ❑ SP10SR, LR, ER and ZR series of short or long distance transceivers using multi-mode or single mode fiber optic cable.
- ❑ SP10TW series of direct attach cables in lengths up to seven meters.
- ❑ SP10BD series of bidirectional transceivers for single mode fiber optic cable with maximum distances of 10 to 40 kilometers
- ❑ SP10T transceiver with RJ-45 connector for links up to 20 meters at 10G with Category 6a copper cable, or 100 meters at 1G.
- ❑ SP10LRM Long Reach Multimode transceiver for OM1 multi-mode fiber optic links up to 220 meters.
- ❑ SP10TM transceiver with RJ-45 connector for speeds of 1G/2.5G/5G/10G.

Note

Industrial (-40 to 85° C) and extended (-40 to 105° C) temperature transceivers are available.

Here are transceiver guidelines:

- ❑ The ports do not support 100M transceivers.
- ❑ They support full-duplex mode only.
- ❑ You can set the port speeds with Auto-Negotiation or manually. The default is Auto-Negotiation.

Transceivers must be purchased separately. For a list of supported transceivers, refer to the product data sheet on the Allied Telesis web site.

LEDs The LEDs are located between the ports. Each port has one LED. Refer to Figure 4.

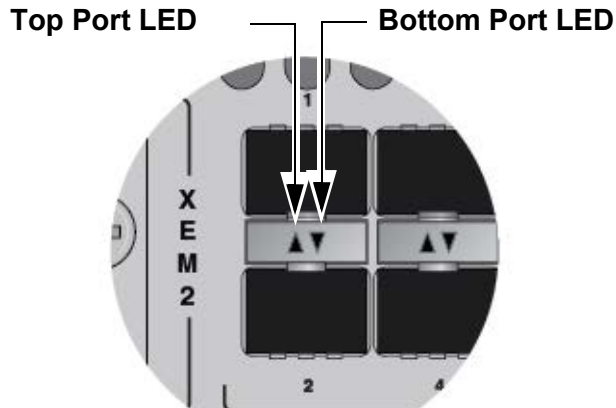

Figure 4. Link and Activity LEDs for 1G SFP and 10G SFP+ Ports

The LEDs display link and activity status. The possible LED states are described in Table 2.

Table 2. Link and Activity Status LEDs for 1G SFP and 10G SFP+ Ports

State	Description
Solid Green	The transceiver has established a 10G link to a network device.
Flashing Green	The transceiver is transmitting or receiving data in 10G.
Solid Amber	The transceiver has established a 1G link to a network device.
Flashing Amber	The transceiver is transmitting or receiving data in 1G.
Off	<p>Possible causes of this state are listed here:</p> <ul style="list-style-type: none"> - The transceiver slot is empty. - The transceiver has not established a link to a network device. - The LEDs are turned off. To turn on the LEDs, use the eco-friendly button in the management panel or the NO ECOFRIENDLY LED command in the command line interface. <hr/> <p>Note The AT-x950-52XSQ and AT-x950-52XTQm Switches do not have the eco-friendly button.</p> <hr/>

Copper Ports on the AT-x950-28XTQm and AT-x950-52XTQm Switches

The specifications for copper ports 1 to 24 on the AT-x950-28XTQm Switch and ports 1 to 48 on the AT-x950-52XTQm Switch are listed in Table 3.

Table 3. Copper Ports on AT-x950-28XTQm and AT-x950-52XTQm Switches

Specification	Description
Port Speed	<p>Here are the supported speeds:</p> <ul style="list-style-type: none"> - 100M - 1G/2.5G/5G/10G <p>Here are the guidelines to setting port speeds:</p> <ul style="list-style-type: none"> - 100M can be set manually or with Auto-Negotiation. - 1/2.5/5/10G require Auto-Negotiation. <p>The default port setting is Auto-Negotiation.</p>
Duplex Mode	Full-duplex only
Maximum Distance	100 meters (328 feet)
Connector	8-pin RJ-45

Note

The network devices connected to the ports must be IEEE 802.3u compliant.

Cable Requirements

The minimum cable requirements are listed here:

- 100M - Standard TIA/EIA 568-B-compliant Category 3 unshielded cabling.
- 1/2.5/5G - Standard TIA/EIA 568-A-compliant Category 5 or TIA/EIA 568-B-compliant Enhanced Category 5 (Cat 5e) unshielded cabling.
- 10G -Standard TIA/EIA 568-C-compliant Category 6a unshielded cabling.

LEDs This section explains the LEDs for the 100M/1G/2.5G/5G/10G copper ports on the AT-x950-28XTQm and AT-x950-52XTQm Switches. Each port has one LED that displays link and activity information. The LEDs are shown in Figure 5.

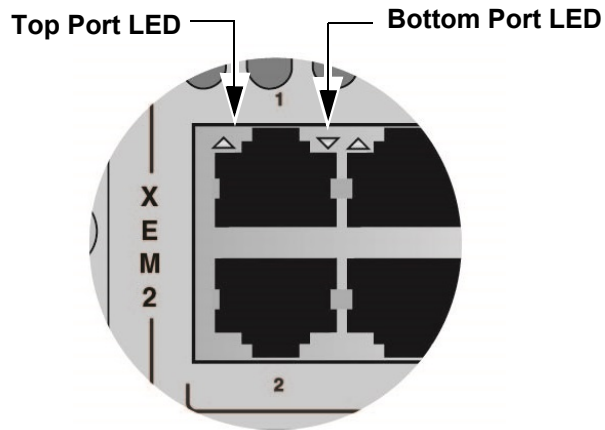

Figure 5. Link and Activity LEDs for the Copper Ports on the AT-x950-28XTQm and AT-x950-52XTQm Switches

The states of the link and activity LEDs are described in Table 4.

Table 4. Link and Activity LEDs for Copper Ports on AT-x950-28XTQm and AT-x950-52XTQm Switches

State	Description
Solid Green	The port has established a 2.5G, 5G, or 10G link to a network device.
Flashing Green	The port is transmitting or receiving data at 2.5G, 5G, or 10G.
Solid Amber	The port has established a 100M or 1G link to a network device.
Flashing Amber	The port is transmitting or receiving data at 100M or 1G.

Table 4. Link and Activity LEDs for Copper Ports on AT-x950-28XTQm and AT-x950-52XTQm Switches (Continued)

State	Description
Off	<p>Possible causes of this state are listed here:</p> <ul style="list-style-type: none">- The port has not established a link with another network device.- The LEDs are turned off. To turn on the LEDs, use the eco-friendly button in the management panel or the NO ECOFRIENDLY LED command in the command line interface. <hr/> <p>Note The AT-x950-52XSQ and AT-x950-52XTQm Switches do not have the eco-friendly button.</p>

Ports for 40G QSFP+ and 100G QSFP28 Transceivers, and Breakout Cables

The x950 Switches have four ports that support the transceivers and cables listed in Table 5.

Table 5. Ports for QSFP+ and QSFP28 Transceivers, and 4x10G Breakout Cables

Switch	Port Numbers	40G QSFP+ Transceivers	100G QSFP28 Transceivers	4x10G Breakout Cables
AT-x950-28XSQ	25, 29, 33, 37	Yes	Yes	Yes
AT-x950-28XTQm	25, 29, 33, 37	Yes	Yes	Yes
AT-x950-52XSQ	49, 53, 57, 61	Yes	Yes	Yes
AT-x950-52XTQm	49, 53, 57, 61	Yes	Yes	Yes

QSFP+ Transceivers

The ports support the following 40G QSFP+ transceivers:

- ❑ AT-QSFPSR4 transceiver - Maximum operating distance of 150m (492 ft) with 12-strand OM4 fiber optic cable.
- ❑ AT-QSFPLR4 transceiver - Maximum operating distance of 2m (6.6 ft) to 10km (6.2 mi) with single-mode fiber optic cable.
- ❑ AT-QSFP1CU and AT-QSFP3CU direct attach cables - Lengths of 1 and 3 meters, respectively.

QSFP28 Transceivers

The ports support the following 100G QSFP28 transceivers:

- ❑ AT-QSFP28SR4 transceiver - Maximum operating distance of 70m (230 ft) or 100m (328 ft) with 12-strand OM3 or OM4 fiber optic cable, respectively. Requires an MPO pluggable optical connector.
- ❑ AT-QSFP28LR4 transceiver - Operating range of 2m (6.6 ft) to 10km (6.2 mi) with single-mode fiber optic cable. Requires a duplex LC connector.
- ❑ AT-QSFP28-1CU and AT-QSFP28-3CU direct attach cables - Lengths of one and three meters, respectively.

Breakout Cables

The ports also support copper and fiber optic break-out cables. The cables convert the ports from single 40G ports to four 10G SFP+ ports. The model names of the copper cables are AT-QSFP-4SFP10G-3CU and AT-QSFP-4SFP10G-5CU. They come in lengths of 3 and 5 meters, respectively. Refer to Figure 6 on page 31.



Figure 6. AT-QSFP-4SFP10G-3CU and AT-QSFP-4SFP10G-5CU Copper Breakout Cables

LEDs The ports for the QSFP28 and QSFP+ transceivers and breakout cables have one link and activity status LED. Refer to Figure 7.

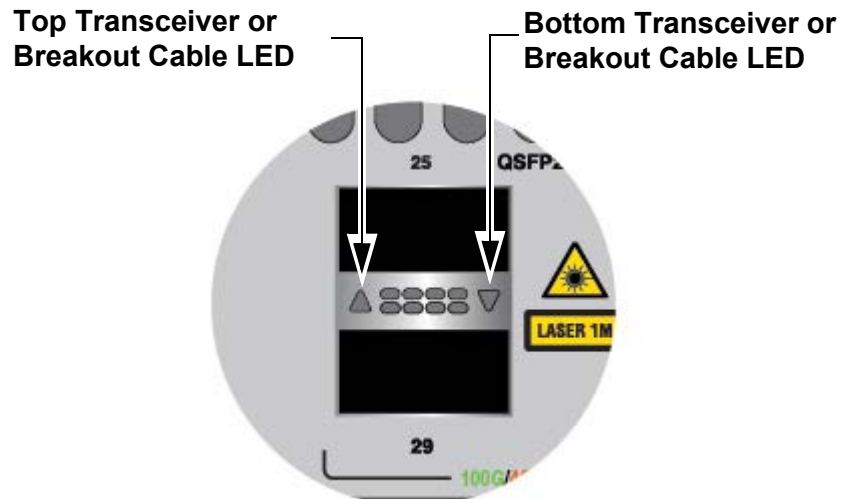

Figure 7. LEDs for Ports 25, 29, 33, and 37 on the AT-x950-28XSQ and AT-x950-28XTQm Switches

Ports 49, 53, 57, and 61 on the AT-x950-52XSQ and AT-x950-52XTQm Switches have one link and activity status LED each. Refer to Figure 8.

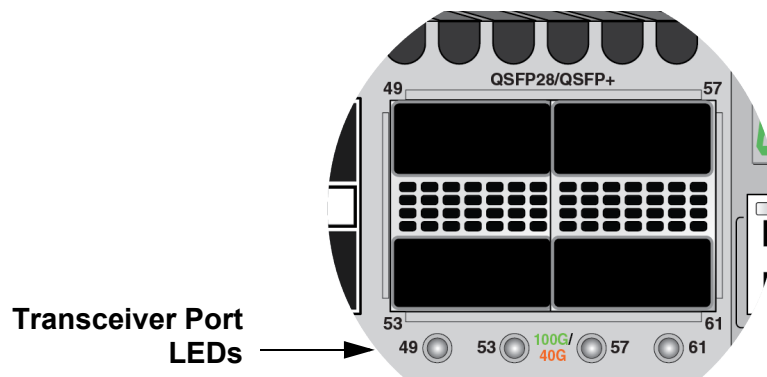

Figure 8. LEDs for Ports 49, 53, 57, and 61 on the AT-x950-52XSQ and AT-x950-52XTQm Switches

LEDs for 40G QSFP+ and 100G QSFP28 Transceivers

The states of the LEDs for 40G QSFP+ and 100G QSFP28 transceivers are defined in Table 6.

Table 6. Link and Activity Status LEDs for 40G QSFP+ and 100G QSFP28 Transceivers

State	Description
Solid Green	The transceiver has established a 100G link to a network device.
Flashing Green	The transceiver is transmitting or receiving data at 100G.
Solid Amber	The transceiver has established a 40G link to a network device.
Flashing Amber	The transceiver is transmitting or receiving data at 40G.
Off	<p>Possible causes of this state are listed here:</p> <ul style="list-style-type: none"> - The transceiver slot is empty. - The transceiver has not established a link to a network device. - The LEDs are turned off. To turn on the LEDs, use the eco-friendly button in the management panel or the NO ECOFRIENDLY LED command in the command line interface. <hr/> <p>Note The AT-x950-52XSQ and AT-x950-52XTQm Switches do not have the eco-friendly button.</p>

LEDs for Breakout Cables

The LED states for breakout cables are described in Table 7.

Table 7. Link and Activity Status LEDs for 10G Breakout Cables

State	Description
Solid Amber	At least one of the four ports on the breakout cable has established a 10G link to a network device.

Table 7. Link and Activity Status LEDs for 10G Breakout Cables

State	Description
Flashing Amber	At least one of the four ports on the breakout cable is sending or receiving data.
Off	<p>Possible causes of this state are listed here:</p> <ul style="list-style-type: none"> - The transceiver slot is empty. - None of the ports on the breakout cable have established a link to a network device. - The LEDs are turned off. To turn on the LEDs, use the eco-friendly button in the management panel or the NO ECOFRIENDLY LED command in the command line interface. <hr/> <p>Note The AT-x950-52XSQ and AT-x950-52XTQm Switches do <i>not</i> have the eco-friendly button.</p>

**Port Numbering
for the
AT-x950-28XSQ
and
AT-x950-28XTQm
Switches**

Table 8 lists the port numbering system for ports 25, 29, 33, and 37 on the AT-x950-28XSQ and AT-x950-28XTQm Switches when the switch is operating as a standalone unit, with the VCStack feature disabled:

Table 8. Port Numbering for Ports 25 to 37

Port	With Fiber Optic Transceiver or Direct Attach Cable	With Breakout Cable
25	port1.0.25	port1.0.25 port1.0.26 port1.0.27 port1.0.28
29	port1.0.29	port1.0.29 port1.0.30 port1.0.31 port1.0.32
33	port1.0.33	port1.0.33 port1.0.34 port1.0.35 port1.0.36

Table 8. Port Numbering for Ports 25 to 37 (Continued)

Port	With Fiber Optic Transceiver or Direct Attach Cable	With Breakout Cable
37	port1.0.37	port1.0.37 port1.0.38 port1.0.39 port1.0.40

Port Numbering for the AT-x950-52XSQ and AT-x950-52XTQm Switches

Table 9 lists the port numbering system for ports 49, 53, 57, and 61 on the AT-x950-52XSQ and AT-x950-52XTQm Switches when the switch is operating as a standalone unit, with the VCStack feature disabled:

Table 9. Port Numbering for Ports 49, 53, 57, and 61

Port	With Fiber Optic Transceiver or Direct Attach Cable	With Breakout Cable
49	port1.0.49	port1.0.49 port1.0.50 port1.0.51 port1.0.52
53	port1.0.53	port1.0.53 port1.0.54 port1.0.55 port1.0.56
57	port1.0.57	port1.0.57 port1.0.58 port1.0.59 port1.0.60
61	port1.0.61	port1.0.61 port1.0.62 port1.0.63 port1.0.64

For more information, refer to “Designating Ports in the Command Line Interface” on page 54.

Management Panel

The components on the management panel on the AT-x950-28XSQ and AT-x950-28XTQm Switches are identified in Figure 9.

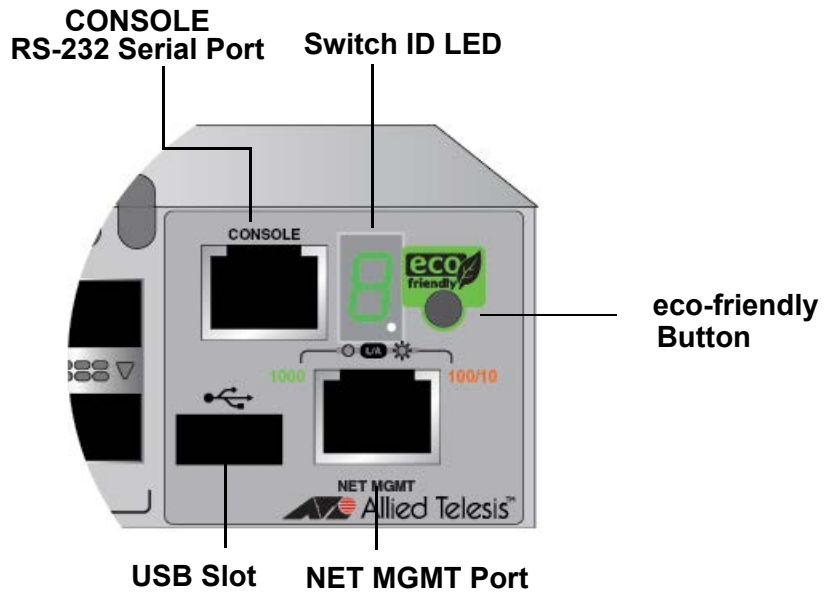

Figure 9. Management Panel on the AT-x950-28XSQ and AT-x950-28XTQm Switches

The components on the management panel on the AT-x950-52XSQ and AT-x950-52XTQm Switches are identified in Figure 10.

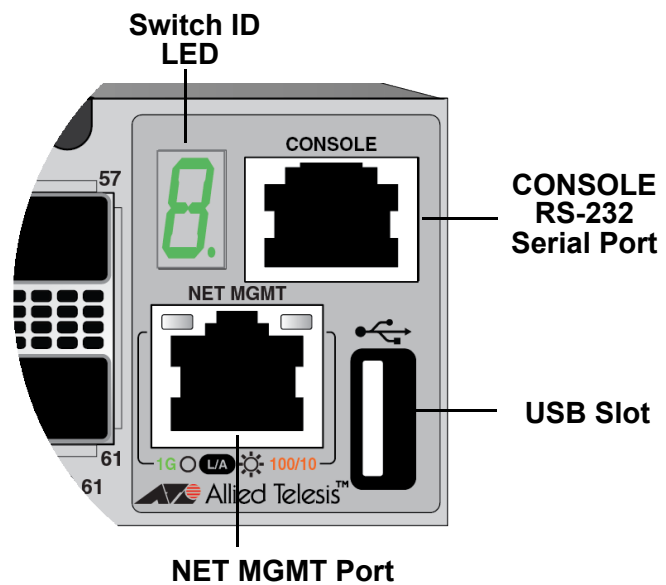

Figure 10. Management Panel on the AT-x950-52XSQ and AT-x950-52XTQm Switches

USB Port

The USB port in the management panel may be used to perform a variety of management functions. Examples of features that support the USB port are listed in Table 10.

Table 10. Examples of Switch Features that Support the USB Port

Feature	AlliedWare Plus Command
File and Configuration Management	
Configure the router using a configuration file on a USB storage device the next time it boots.	BOOT CONFIG-FILE
Direct the router to a USB storage device for the AlliedWare Plus management software the next time it boots.	BOOT SYSTEM
Copy files to or from a USB storage device, or create duplicate files on the storage device.	COPY
Save debug files on a USB storage device to diagnose and troubleshoot network issues.	COPY DEBUG MOVE DEBUG
Save the running-config file on a USB storage device or copy a file from a USB storage device into the running-config. The file contains the router's current configuration, including commands not yet saved in the startup-config file.	COPY RUNNING-CONFIG
Save the startup-config file on a USB storage device, or copy a file from a USB storage device to the startup-config file. The file contains the router's currently saved configuration settings.	COPY STARTUP-CONFIG
Save autoboot.txt files on a USB storage device. The router uses the files to restore a release file and/or configuration file to its file system.	CREATE AUTOBOOT
Configure the switch to restore a release file and/or configuration file from a USB storage device.	AUTOBOOT ENABLE
List the files on a USB storage device.	DIR
Edit files on a USB storage device.	EDIT

Table 10. Examples of Switch Features that Support the USB Port

Feature	AlliedWare Plus Command
Close all open files and stop all management actions on a USB storage device. You should always perform this command before removing a storage device from the drive, to prevent corrupting data files.	UNMOUNT
Logging	
Delete the external log file from a USB storage device.	CLEAR LOG EXTERNAL
Copy the buffered log onto a USB storage device.	COPY BUFFERED-LOG
Copy the permanent log onto a USB storage device.	COPY PERMANENT-LOG
Save syslog messages in a file on a USB storage device.	LOG EXTERNAL
Display the contents of the external log on a USB storage device.	SHOW LOG EXTERNAL
Local RADIUS Server	
Create a set of local RADIUS server users from MAC addresses.	COPY FDB-RADIUS-USERS
Copy the local RADIUS server user data to a file.	COPY LOCAL-RADIUS-USER-D B
DHCP Snooping	
Store the dynamic entries in the DHCP snooping database in a file.	IP DHCP SNOOPING DATABASE
Virtual Chassis Stacking	
Delete files from the USB storage devices on all stack members.	DELETE STACK-WIDE FORCE
Display the directories on a USB storage devices on all stack members.	DIR STACK-WIDE

Table 10. Examples of Switch Features that Support the USB Port

Feature	AlliedWare Plus Command
Allied Tesis Management Framework (AMF)	
Remove guest node's backup files.	ATMF BACKUP GUESTS DELETE
Initiate manual synchronization of all guest backup file-sets across remote file servers and backup media.	ATMF BACKUP GUESTS SYNCHRONIZE
Enable or disable AMF backup redundancy.	ATMF BACKUP REDUNDANCY ENABLE
Reboot the nodes in an AMF working-set or upgrade the management software one AMF device at a time.	ATMF REBOOT-ROLLING
Delete a node's recovery files	CLEAR ATMF RECOVERY-FILE
Set the configuration file to use during the next boot cycle.	CONFIGURE BOOT CONFIG
Autonomous Wave Control	
Allow AlliedWare Plus to place the wireless network into emergency mode when you insert a pre-prepared USB storage device.	EMERGENCY-MODE USB ENABLE
Specify the key for placing the wireless network into emergency mode.	EMERGENCY-MODE USB KEY
Store wireless client and neighbor AP log files.	LOG ENABLE DESTINATION
Prepare a USB storage device to place the wireless network into emergency mode,	WIRELESS EMERGENCY-MODE USB MARK KEY
Retrieve and store technical support files from managed wireless access points.	WIRELESS GET-TECH AP
Retrieve and store technical support files from managed wireless access points that use the specified AP Profile ID.	WIRELESS GET-TECH AP-PROFILE

Table 10. Examples of Switch Features that Support the USB Port

Feature	AlliedWare Plus Command
Retrieves and stores technical support files from managed wireless access points that use the specified Smart Connect (SC) Profile ID.	WIRELESS GET-TECH SC-PROFILE
Trigger	
Configure a trigger that the router performs when a USB storage device is inserted or removed in the USB port.	TYPE USB

NET MGMT Ethernet Management Port

The switch uses the NET MGMT port as a separate routed eth0 interface. The interface is not part of the switching matrix, but the switch can route traffic in or out of the port from the network ports and XEM2 Line Card. Here are the guidelines:

- ❑ The port should only be used for initial configuration and maintenance access to the chassis.
- ❑ The NET MGMT port has a standard 8-pin RJ-45 connector and operates at 10M/100M/1000M in either half- or full-duplex mode.
- ❑ The default setting for the port is Auto-Negotiation, which sets the speed and duplex mode automatically. You may disable Auto-Negotiation and configure the port manually.
- ❑ The wiring configuration of the NET MGMT port is set automatically with automatic MDIX detection. You can disable automatic MDIX detection and set the wiring configuration manually.
- ❑ The port is referred to as eth0 in the management software.

The minimum cable requirements for the port are listed here:

- ❑ 10M/100M - Standard TIA/EIA 568-B-compliant Category 3 unshielded cabling.
- ❑ 1000M - Standard TIA/EIA 568-A-compliant Category 5 or TIA/EIA 568-B-compliant Enhanced Category 5 (Cat 5e) unshielded cabling.

For instructions on how to configure the NET MGMT port, refer to the *Software Reference for x950 Switch, AlliedWare Plus Operating System*.

The Network Management (NET MGMT) port has one Status LED, described in Table 11.

Table 11. NET MGMT Port LED

State	Description
Solid Green	The port has established a 1000M link with a network device.
Flashing Green	The port is transmitting or receiving data at 1000M.
Solid Amber	The port has established a 10M or 100M link.
Flashing Amber	The port is transmitting or receiving data at 10M or 100M.
Off	The port has not established a link to a network device.

Console (RS-232) Port

You may use the Console Port to conduct local management sessions with the switch. Local management sessions require a terminal or PC with a terminal emulation program, and the management cable that comes with the switch. The switch does not need an Internet Protocol (IP) address for local management sessions because they are not conducted over a network. For instructions, refer to “Starting a Local Management Session” on page 206.

Note

The first management session of the switch can be either a local session or a remote session over your network through the NET MGMT port. For remote management, the switch uses either its default IP address 192.168.42.42 or an address assigned to it by a DHCP server. For instructions on remote management sessions, refer to the *Software Reference for x950 Switches, AlliedWare Plus Operating System*.

Switch ID LED

The Switch ID LED, shown in Figure 9 on page 35 or Figure 10 on page 35, displays a variety of information. Figure 11 on page 41 shows the states of the LED when the eco-friendly mode is disabled.

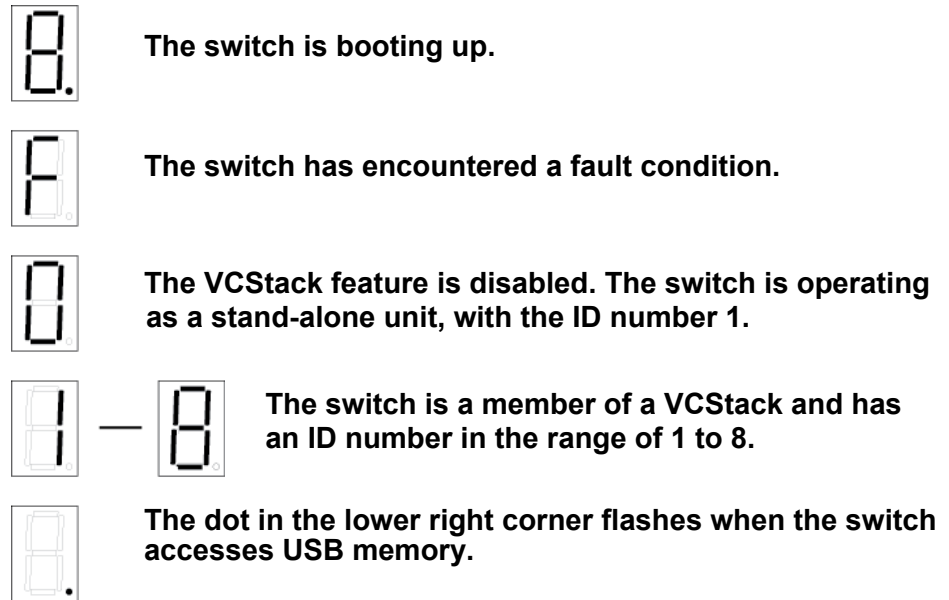

Figure 11. Switch ID LED with the eco-friendly Mode Disabled

The switch displays the letter “F” for fault on the ID LED if it detects one of the following problems:

- A cooling fan has failed.
- The switch is about to shut down because its internal temperature is outside the normal operating range.

Note

You can use the `SHOW SYSTEM ENVIRONMENT` command in the command line interface to identify the source of the problem.

Figure 12 illustrates the states of the LED when the eco-friendly mode is enabled and the switch is operating in the low power mode.

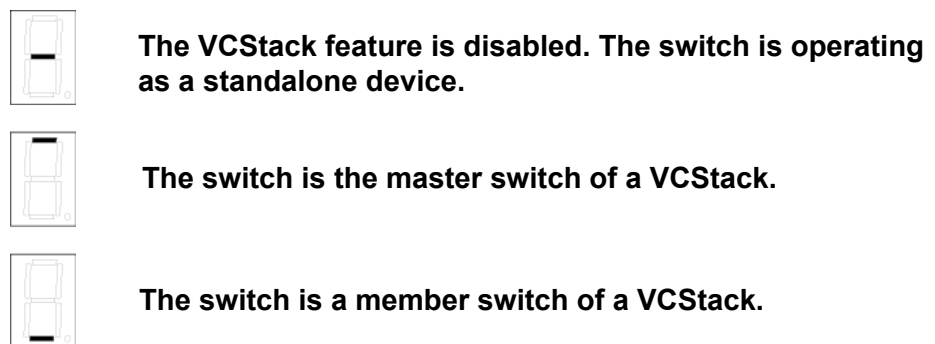

Figure 12. Switch ID LED with the eco-friendly Mode Enabled

eco-friendly Button

You use the eco-friendly button on the management panel to turn the LEDs on or off. You might turn off the LEDs when you are not using them to monitor the switch, to conserve electricity. When the LEDs are off, the overall power consumption of the chassis is reduced by approximately 2 watts.

The button controls all the port LEDs, except for the L/A LED for the NET MGMT port. Additionally, the button does not control the LEDs on the power supplies.

Note

The AT-x950-52XSQ and AT-x950-52XTQm Switches do not have the eco-friendly button. However, the eco-friendly mode can be turned on or off with the ECOFRIENDLY LED or NO ECOFRIENDLY LED command in the command line interface.

Direct Attach Cables

The optional direct attach cables listed in Table 12 offer an economical way to add 10G, 40G, and 100G connections over short distances for switch base ports and ports on XEM2 Line Cards.

Table 12. Optional Direct Attach Cables

Switch Ports	XEM2 Line Card	Speed	Direct Attach Cable
Ports 1 to 24 on AT-x950-28XSQ Ports 1 to 48 on AT-x950-52XSQ	AT-XEM2-8XSTm AT-XEM2-12XS AT-XEM2-12XS v2 ¹	10G	SP10TW1 - 1 meter SP10TW3 - 3 meters SP10TW7 - 7 meters
Ports 25, 29, 33, 37 on AT-x950-28XSQ and AT-x950-28XTQm Ports 49, 53, 57, 61 on AT-x950-52XSQ and AT-x950-52XTQm	AT-XEM2-4QS AT-XEM2-1CQ	40G 100G	AT-QSFP1CU - 1 meter AT-QSFP3CU - 3 meters AT-QSFP28-1CU - 1 meter AT-QSFP28-3CU - 3 meters

1. The AT-XEM2-12XS v2 Card supports the SP10TW1 and SP10TW3 cables. It does not support the SP10TW7 cable.

AT-PWR600 and AT-PWR600R AC and DC Power Supplies

The x950 Switches have four power supplies:

- ❑ AT-PWR600
- ❑ AT-PWR600R
- ❑ AT-PWR600-80
- ❑ AT-PWR600R-80

The power supplies differ in terms of AC or DC input power and airflow direction. Table 13 lists the power supplies, their input power, and airflow directions. Also included are the corresponding fan models for the power supplies.

Table 13. AT-PWR600 and AT-PWR600R AC and DC Power Supplies

Power Supply¹	AC or DC Input	Airflow Direction in Switch	Fan Module
AT-PWR600	AC	Front-to-rear	AT-FAN05
AT-PWR600R	AC	Rear-to-front	AT-FAN05R
AT-PWR600-80	DC	Front-to-rear	AT-FAN05
AT-PWR600R-80	DC	Rear-to-front	AT-FAN05R

1. The power supply model names are on labels on the top panels of the power supplies. Refer to Figure 13 on page 45 and Figure 16 on page 48.

The airflow directions of the power supplies and fan modules in the switch must be the same. Otherwise, the switch might overheat from inadequate ventilation and cooling. Here are the guidelines:

- ❑ Switches with AT-PWR600 AC or AT-PWR600-80 DC Power Supplies must have AT-FAN05 fan modules.
- ❑ Switches with AT-PWR600R AC or AT-PWR600R-80 DC Power Supplies must have AT-FAN05R fan modules.

The AT-PWR600 AC Power Supply is shown in Figure 13.

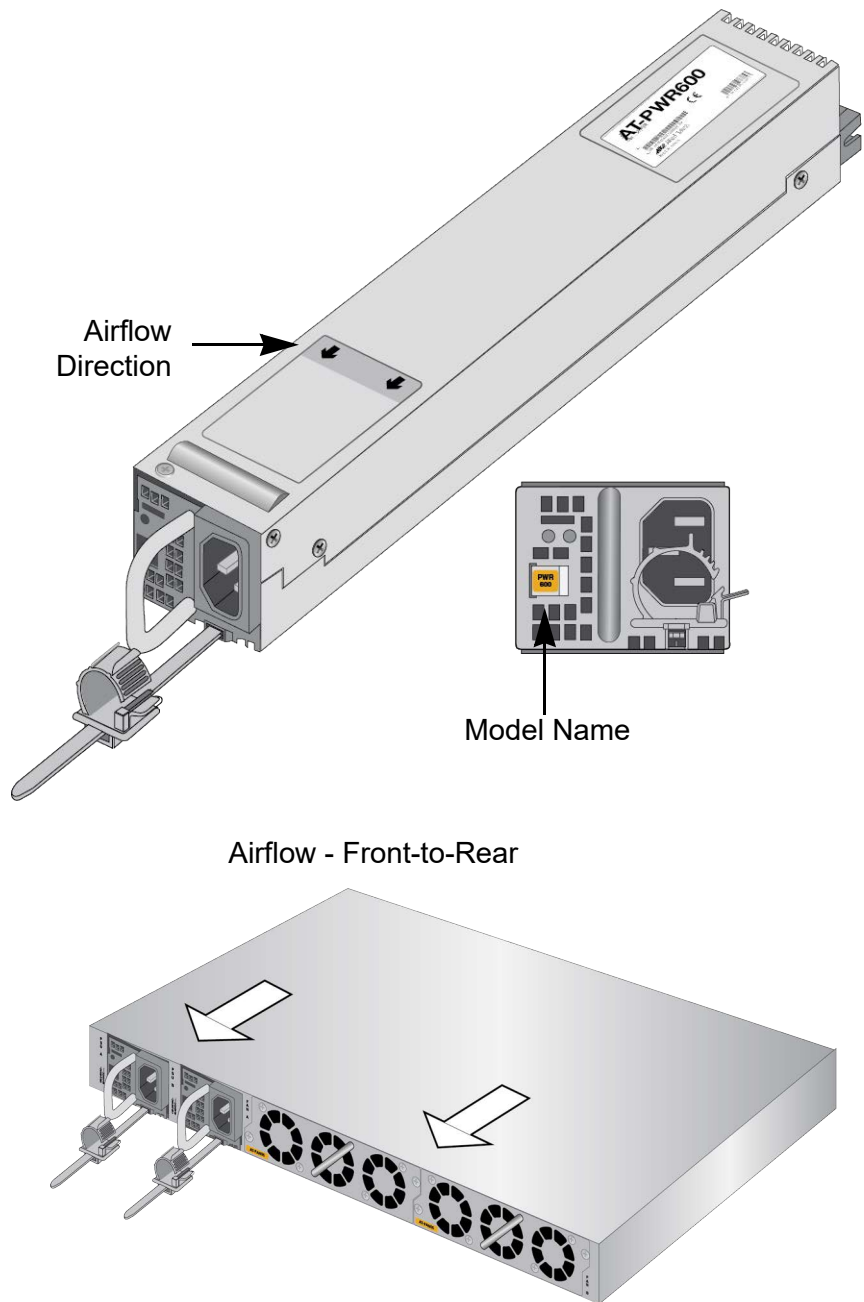

Figure 13. AT-PWR600 Power Supply and AT-FAN05 Fan Module

The AT-PWR600R AC Power Supply is shown in Figure 14.

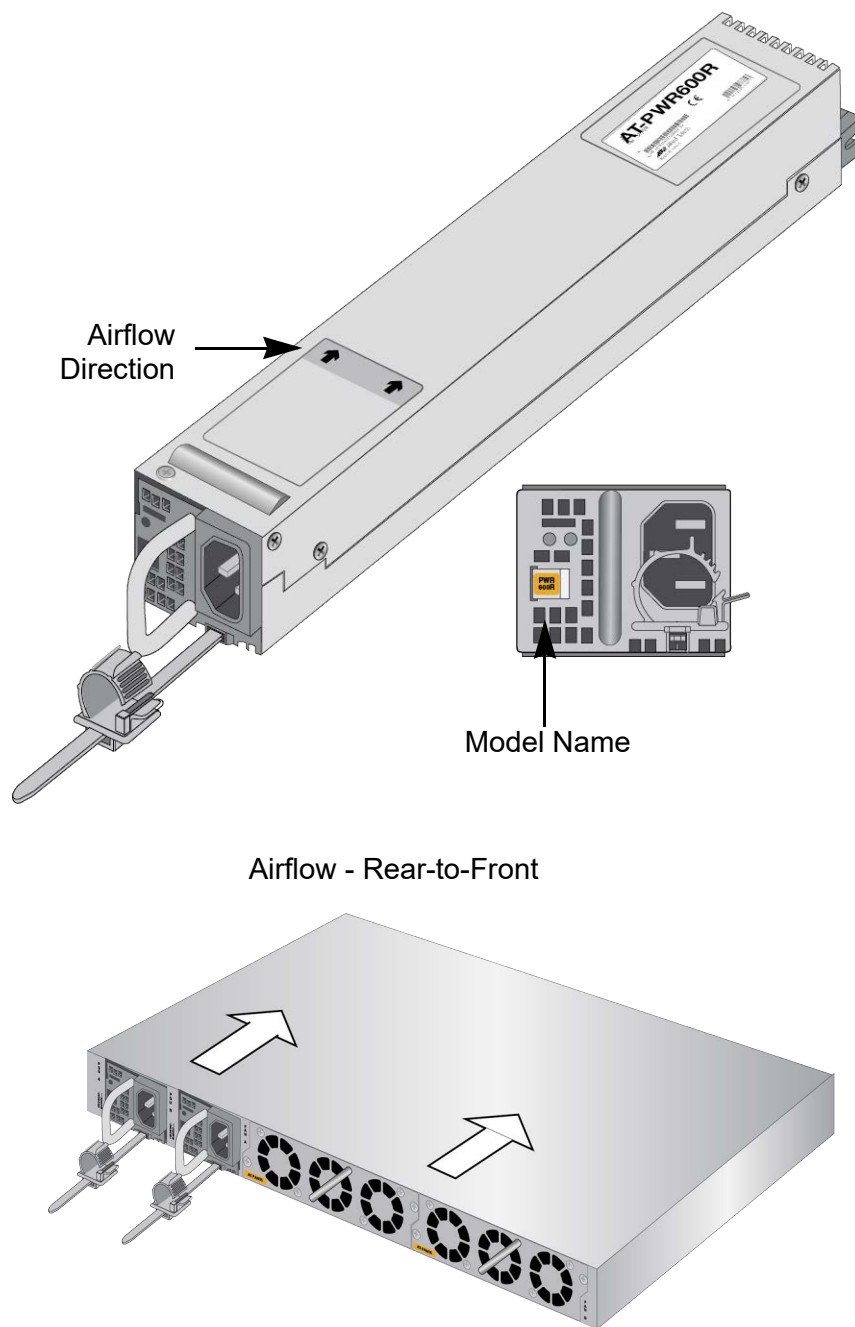
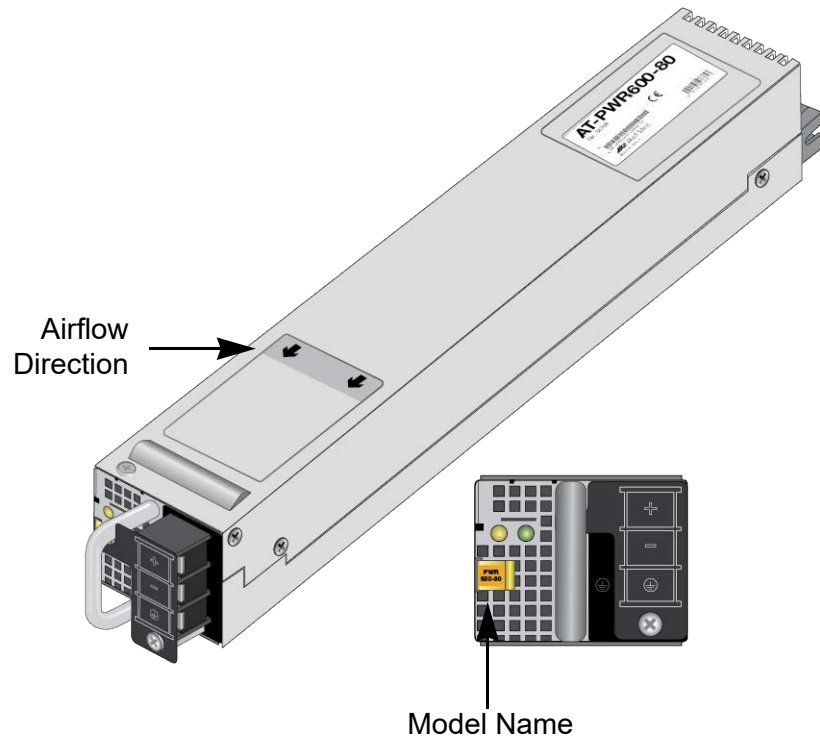

Figure 14. AT-PWR600R AC Power Supply and AT-FAN05R Fan Module

The AT-PWR600-80 DC Power Supply is shown in Figure 15.



Airflow - Front-to-Rear

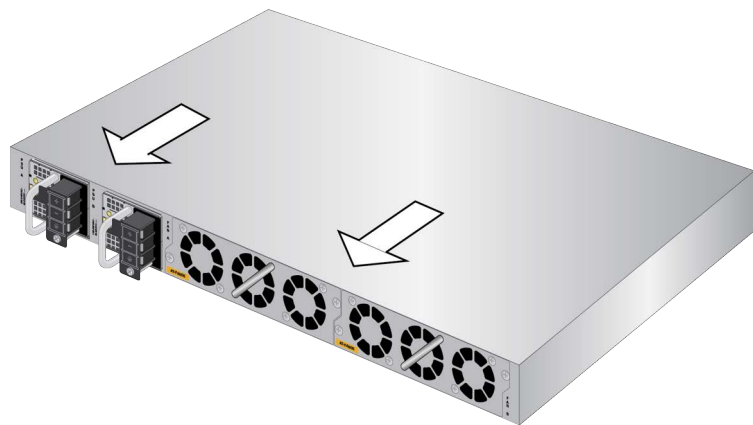
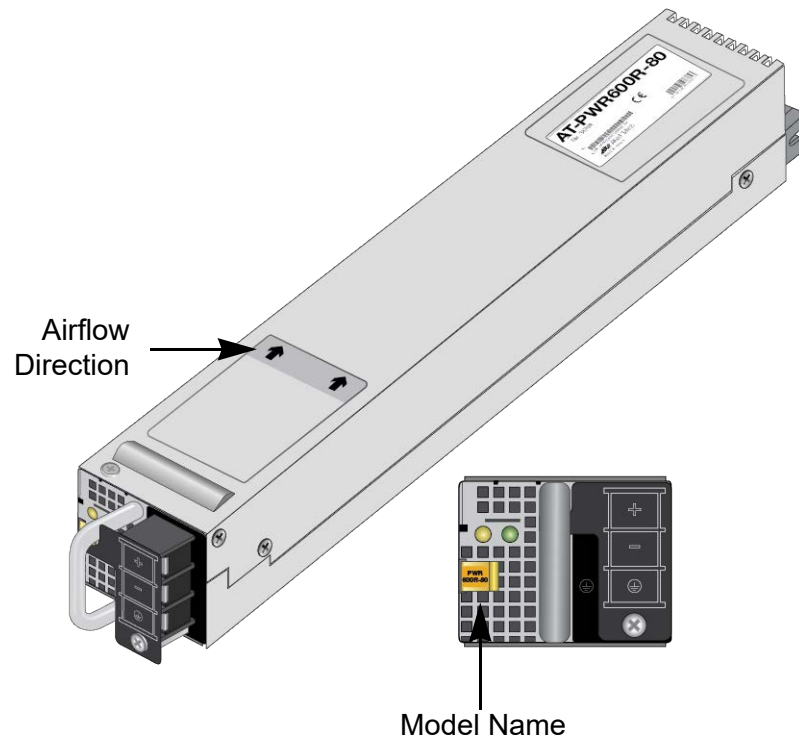

Figure 15. AT-PWR600-80 DC Power Supply and AT-FAN05 Fan Module

The AT-PWR600R-80 DC Power Supply is shown in Figure 16.



Airflow - Rear-to-Front

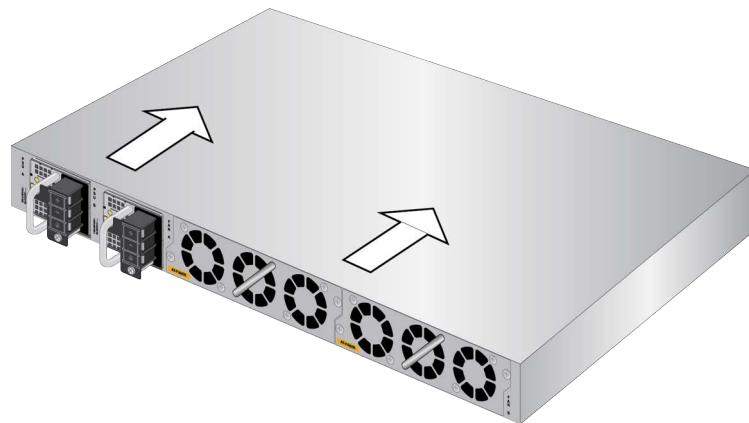

Figure 16. AT-PWR600R-80 DC Power Supply and AT-FAN05R Fan Module

Power Supply Guidelines

Here are guidelines for the AT-PWR600 AC and AT-PWR600-80 DC Power Supplies:

Note

The x950 Switches come with two pre-installed AT-FAN05 modules. You must replace them with two AT-FAN05R modules if you install AT-PWR600R or AT-PWR600R-80 Power Supplies.

- ❑ You can install either one or two power supplies in the switch. A single power supply can power a fully equipped switch. Installing two power supply units adds power redundancy.
- ❑ The power supplies are installed in the PSU A and PSU B slots in the rear panel of the chassis. If you are installing only one power supply, Allied Telesis recommends installing it in PSU A slot because that slot does not come with a blank slot cover.
- ❑ If you are installing two power supplies, they can be both AC, both DC, or AC and DC.
- ❑ The airflow directions of the power supplies and fan modules must be the same. Otherwise, the ventilation in the switch might be inadequate, causing the switch to overheat. Table 13 on page 44 and Table 16 on page 52 lists the power supplies and fan modules that have the same airflow directions.
- ❑ The switches do not come with power supply units. They are purchased separately.
- ❑ The power supplies are field-replaceable and hot-swappable. If the switch has two power supply units and one fails, you do not have to power off the operational power supply unit to replace the failed unit.

LEDs The two LEDs on the front panels of the AT-PWR600 and AT-PWR600R Power Supplies are described in Table 14.

Table 14. LEDs on the AT-PWR600 and AT-PWR600R AC Power Supplies

Green LED	Amber LED	Description
Solid green	Off	The power supply is operating normally.
Blinking green	Off	The power supply is in the standby mode.

Table 14. LEDs on the AT-PWR600 and AT-PWR600R AC Power Supplies (Continued)

Green LED	Amber LED	Description
Solid green	Blinking amber	<p>The power supply is experiencing a warning condition, but is still operating. Possible causes are listed here:</p> <ul style="list-style-type: none"> - The power supply is overheating. - The speed of its fan is too low. - Its output current is too high. - The input voltage from the AC power source is too low.
Off	Solid amber	<p>The power supply shut down because it experienced a fault condition. Possible causes are listed here:</p> <ul style="list-style-type: none"> - The power supply overheated. - The power supply's fan stopped or is too slow. - The output current from the power supply to the switch is too high. - The input voltage from the AC power source is too low.

The LEDs on the AT-PWR600-80 and AT-PWR600R-80 DC Power Supplies are defined in Table 15.

Table 15. LEDs on the AT-PWR600-80 and AT-PWR600R-80 DC Power Supplies

Green LED	Amber LED	Description
Solid green	Off	The power supply is operating normally.
Blinking green	Off	The power supply is in the standby mode.

Table 15. LEDs on the AT-PWR600-80 and AT-PWR600R-80 DC Power Supplies (Continued)

Green LED	Amber LED	Description
Solid green	Blinking amber	<p>The power supply is experiencing a warning condition, but is still operating. Possible causes are listed here:</p> <ul style="list-style-type: none"> - The power supply is overheating. - The speed of its fan is too low. - Its output current is too high. - The input voltage from the DC power source is too low.
Off	Solid amber	<p>The power supply shut down because it experienced a fault condition. Possible causes are listed here:</p> <ul style="list-style-type: none"> - The power supply overheated. - The power supply's fan stopped or is too slow. - The output current from the power supply to the switch is too high. - The input voltage from the DC power source is too low.

AT-FAN05 and AT-FAN05R Fan Modules

The x950 Switches have two fan modules:

- ❑ AT-FAN05
- ❑ AT-FAN05R

Refer to Figure 17.

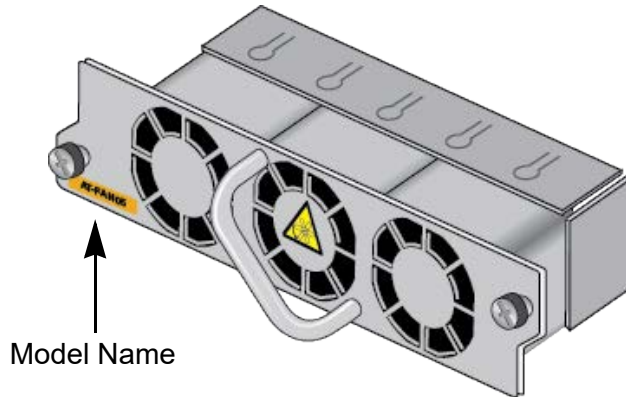

Figure 17. AT-FAN05 and AT-FAN05R Fan Modules

The two fan modules have different airflow directions:

- ❑ AT-FAN05 module: Front-to-rear of switch. The module's fans pull air from the switch.
- ❑ AT-FAN05R module: Rear-to-front of switch. The module's fans drive air into the switch.

The airflow directions of the fan modules and power supplies in the switch must be the same. Otherwise, the switch might overheat from inadequate ventilation and cooling. Table 16 lists the AT-FAN05 and AT-FAN05R fan modules with the matching power supply units.

Table 16. Fan Modules and Power Supplies

Fan Module ¹	Matching Power Supply	Airflow Direction
AT-FAN05	AT-PWR600 (AC) AT-PWR600-80 (DC)	Front-to-rear of switch
AT-FAN05R	AT-PWR600R (AC) AT-PWR600R-80 (DC)	Rear-to-front of switch

1. The model name is on the front panel of the fan module. See Figure 17.

For information on the power supplies, refer to “AT-PWR600 and AT-PWR600R AC and DC Power Supplies” on page 44.

Here are the guidelines to the fan modules:

Note

The x950 Switches come with two pre-installed AT-FAN05 modules in FAN A and FAN B slots on the rear panel. You must replace the fan modules with two AT-FAN05R modules if you install AT-PWR600R or AT-PWR600R-80 Power Supplies.

- ❑ The switch must have two fan modules for adequate cooling and ventilation.
- ❑ The switch comes with two pre-installed AT-FAN05 fan modules.
- ❑ The two fan modules must be the same. Installing different fan modules in the switch may result in inadequate ventilation and cooling, which may cause the switch to overheat.
- ❑ The airflow directions of the fan modules and power supplies in the switch must be the same. Otherwise, the switch might overheat from inadequate ventilation and cooling. Refer to Table 13 on page 44 or Table 16 on page 52 for matching power supplies and fan modules.
- ❑ The fan modules are field-replaceable and hot-swappable. You do not have to power off the switch to replace them.
- ❑ The switch automatically adjusts the fan speeds according to its internal temperature.

Designating Ports in the Command Line Interface

The individual ports on the switch are identified with the PORT parameter in the command line interface of the AlliedWare Plus management software. The format of the parameter for a standalone switch is shown in Figure 18.

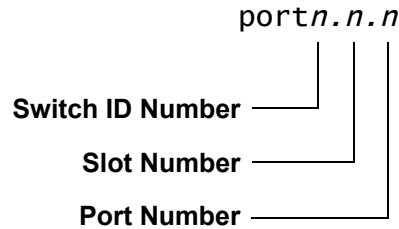

Figure 18. PORT Parameter in the Command Line Interface for VCStack

The three parts of the PORT parameter are defined in Table 17.

Table 17. PORT Parameter Format for a Standalone Switch

Number	Description
Switch ID Number	Identifies the switch’s unique ID number in the stack. The switches display their ID numbers on the Switch ID LEDs on the front panels. The range is 1 to 8. Switches that are operating as a standalone switches display 0 on the LED.
Slot Number	Identifies whether ports are base ports or ports on an XEM2 Line Card. The slot values are: <ul style="list-style-type: none"> - 0 - Identifies base ports. - 1- Indicates ports on the XEM2 Line Card in the AT-x950-28XSQ and AT-x950-28XTQm Switches. Refer to Figure 19 on page 55. <div style="border: 1px solid black; padding: 5px; margin-top: 10px;"> <p>Note The AT-x950-52XSQ and AT-x950-52XTQm Switches do not support XEM2 Line Cards.</p> </div>
Port Number	Identifies a port number.

Base Ports and XEM2 Line Card Ports

The AT-x950-28XSQ and AT-x950-28XTQm Switches have two types of ports. They have the ports that come with the switch, referred to as base ports, and ports on the optional XEM2 Line Cards. You use different slot numbers to identify the two groups of ports in the command line interface. The slot number for the base ports is “0”. The slot number for ports on the XEM2 Line Card is “1”. Refer to Figure 19.

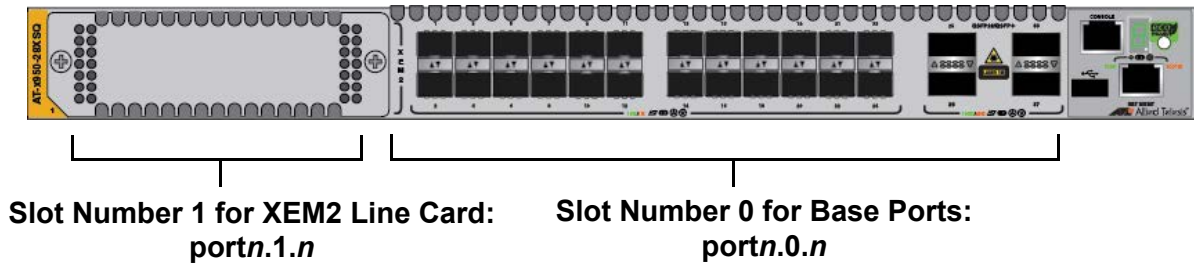

Figure 19. Slot Numbers for Port Numbering on AT-x950-28XSQ and AT-x950-28XTQm Switches

Note

The AT-x950-52XSQ and AT-x950-52XTQm Switches have base ports only. The slot number for their ports in the PORT parameter is always “0”.

Examples for the PORT Parameter on Base Ports

Here are examples of the PORT parameter in the INTERFACE command for base ports on switches in a VCStack. You must include the PORT parameter with port numbers when specifying individual ports. The first example enters the port interface modes for base ports 11 and 14 on a switch with the ID 1:

```
awplus> enable
awplus# configure terminal
awplus(config)# interface port1.0.11,port1.0.14
```

The example enters the port interface modes for base ports 1 and 9 on a switch with the ID 2:

```
awplus> enable
awplus# configure terminal
awplus(config)# interface port2.0.1,port2.0.9
```

When specifying a range of ports, include the PORT parameter in the first port number, and omit it from the last port number. This example enters the port interface modes for base ports 6 to 10 on a switch with the ID 4:

```
awplus(config)# interface port4.0.6-4.0.10
```

You can enter the port interface modes of ports in different switches in the stack with the same command. This example enters the port interface modes for base port 5 on a switch with the ID 4 and port 13 on a switch with the ID 5:

```
awplus(config)# interface port4.0.5,port5.0.13
```

Examples of the PORT Parameter for XEM2 Line Cards

These examples apply to the XEM2 expansion slots in the AT-x950-28XSQ and AT-x950-28XTQm Switches. The first example enters the port interface modes for ports 4 and 5 on the XEM2 Line Card in the expansion slot on a switch with the ID 3:

```
awplus(config)# interface port3.1.4,port3.1.5
```

You can enter the port interface modes of both base ports and XEM2 Line Card ports with the same command, provided the ports are the same type. This example enters the port interface mode for base port 6 and line card port 5 on a switch with the ID 5:

```
awplus(config)# interface port5.0.6,port5.1.5
```

Examples of the PORT Parameter for Breakout Cables

The four 40G/100G QSFP+/QSFP28 ports on the switches and the four 40G QSFP+ ports on the AT-XEM2-4QS Line Card support breakout cables. The cables convert a port into four individual 10G connections that function as independent ports. An example of a breakout cable is shown in Figure 20.



Figure 20. Copper Breakout Cable

The port numbers with and without breakout cables for the 40G/100G QSFP+/QSFP28 ports on the AT-x950-28XTQm and AT-x950-28XSQ Switches are listed in Table 18 on page 56.

Table 18. Port Numbers with and without Breakout Cables on the AT-x950-28XTQm and AT-x950-28XSQ Switches

Port Numbers without Breakout Cables	Port Numbers with Breakout Cables
25	25-28
29	29-32
33	33-36
37	37-40

The port numbers with and without breakout cables for the 40G/100G QSFP+/QSFP28 ports on the AT-x950-52XTQm and AT-x950-52XSQ Switches are listed in Table 19.

Table 19. Port Numbers with and without Breakout Cables on the AT-x950-52XTQm and AT-x950-52XSQ Switches

Port Numbers without Breakout Cables	Port Numbers with Breakout Cables
49	49-52
53	53-56
57	57-60
61	61-64

The port numbers with and without breakout cables for the ports on the AT-XEM2-4QS Line Card are listed in Table 20.

Table 20. Port Numbers with and without Breakout Cables on the AT-XEM2-4QS Line Card

Port Numbers without Breakout Cables	Port Numbers with Breakout Cables
1	1-4
5	5-8
9	9-12
13	13-16

To identify a 40G/100G port without a breakout cable in the command line interface, use the first port of the range. For example, to enter the port interface mode in the command line interface for port 33 in the AT-x950-28XSQ or AT-x950-28XTQm Switch with the ID 1, you enter these commands:

```
awplus> enable
awplus# configure terminal
awplus(config)# interface port1.0.33
```

This example enters the port interface mode for 40G/100G port 57 in the AT-x950-52XTQm or AT-x950-52XSQ Switch with the ID 7:

```
awplus> enable
awplus# configure terminal
awplus(config)# interface port7.0.57
```

The four connectors on a breakout cable are numbered 1 to 4, with each connector functioning as a separate port. You can configure each port separately in the command line interface. For example, to enter the port interface mode for connector 3 on the breakout cable in port 57 of the AT-x950-52XSQ or AT-x950-52XTQm Switch with the ID 1, you enter these commands:

```
awplus> enable
awplus# configure terminal
awplus(config)# interface port1.0.59
```

To enter the port interface mode for connector 4 on the breakout cable in port 13 of the AT-XEM2-4QS Line Card with the ID 2, you enter these commands:

```
awplus> enable
awplus# configure terminal
awplus(config)# interface port2.1.16
```

For further instructions, refer to the *Software Reference for x950 Switches, AlliedWare Plus Operating System*.

Software and Hardware Releases

The software and hardware releases for the AlliedWare Plus operating software and x950 Switches are listed in Table 21.

Table 21. Software and Hardware Releases

Software Version	Hardware / VCStack
v5.4.8-2	AT-x950-28XSQ Switch AT-XEM2-12XT Line Card AT-XEM2-12XS Line Card AT-XEM2-4QS Line Card AT-XEM2-1CQ Line Card VCStack - Stacks up to two switches.
v5.4.9	VCStack - Stacks up to four switches.*
v5.4.9-1	AT-x950-28XTQm Switch AT-XEM2-12XTm Line Card AT-XEM2-12XT Line Card - Added 100M port speed
v5.4.9-2	AT-XEM2-8XSTm Line Card AT-XEM2-12XS v2 Line Card
v5.4.9-2.3	VCStack - Stacks up to eight switches.*
v5.5.0-1	AT-x950-52XSQ Switch
v5.5.1-0.1	AT-x950-52XTQm Switch

* For more information, see the *x950 Series Switches Installation Guide for Virtual Chassis Stacking*.

Chapter 2

XEM2 Ethernet Line Cards

The chapter contains the following sections:

- “Overview” on page 62
- “AT-XEM2-8XSTm Line Card” on page 65
- “AT-XEM2-12XT Line Card” on page 69
- “AT-XEM2-12XTm Line Card” on page 71
- “AT-XEM2-12XS and AT-XEM2-12XS v2 Line Cards” on page 73
- “AT-XEM2-4QS Line Card” on page 76
- “AT-XEM2-1CQ Line Card” on page 78

Overview

The AT-x950-28XSQ and AT-x950-28XTQm Switches have one expansion slot on the front panel for an optional XEM2 Line Card. See Figure 21.

Note

The AT-x950-52XSQ-52XSQ and AT-x950-52XTQm Switches do not support XEM2 Line Cards.

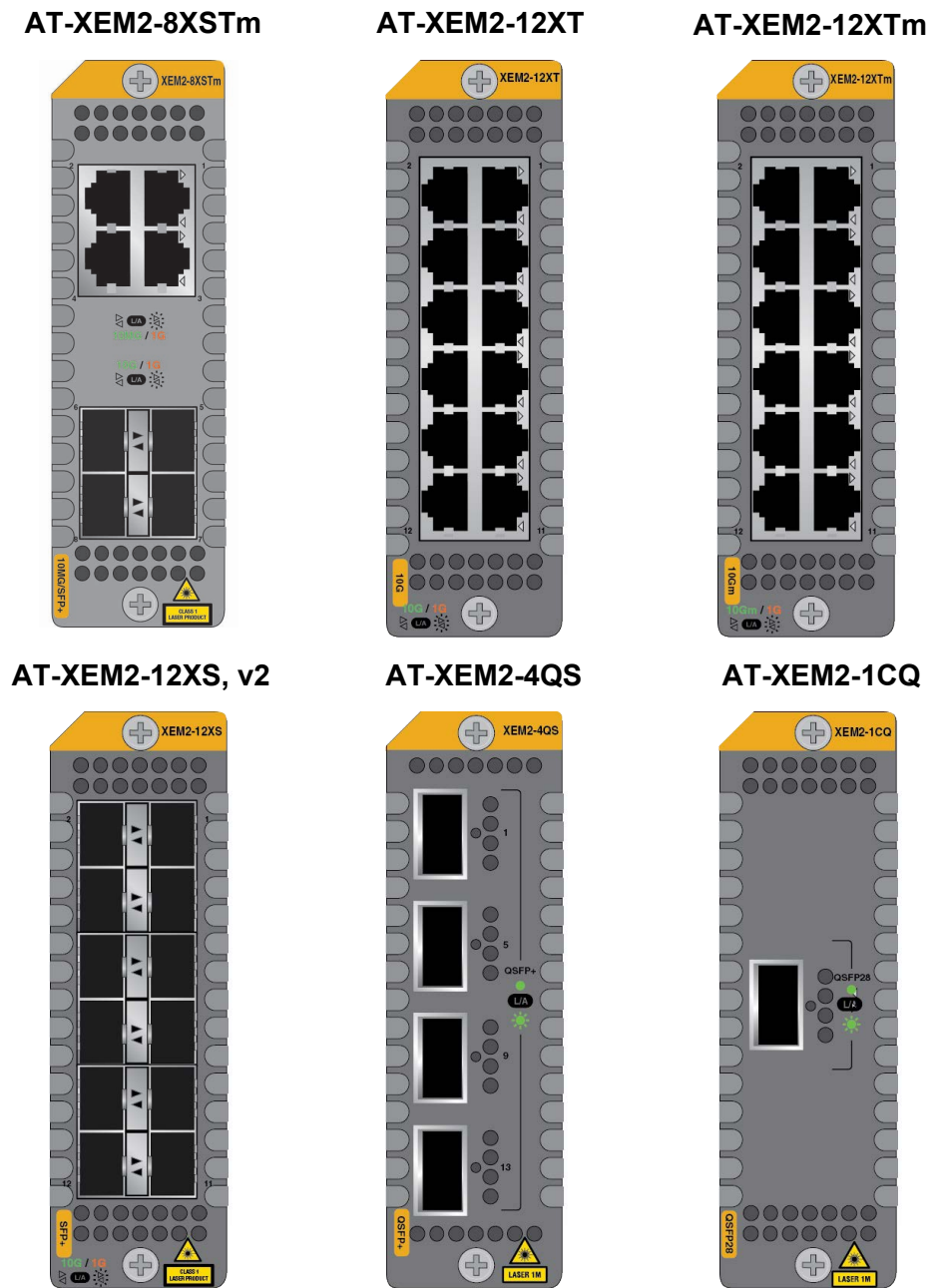

Figure 21. XEM2 Ethernet Line Cards

The XEM2 Ethernet Line Cards are described in Table 22.

Table 22. XEM2 Ethernet Line Cards

Line Card	Description
AT-XEM2-8XSTm	<p>Four copper ports (1-4) with RJ-45 connectors that support the following speeds:</p> <ul style="list-style-type: none"> - 100M - 1G/2.5G/5G/10G <p>Four ports (5-8) that support the following types of transceivers:</p> <ul style="list-style-type: none"> - 1G SFP - 10G SFP+ - 10G one meter AT-SP10TW1 and three meter AT-SP10TW3 direct connect twinax cables. (The card does not support the seven meter AT-SP10TW7 cable.) <p>Refer to “AT-XEM2-8XSTm Line Card” on page 65.</p>
AT-XEM2-12XT	<p>12 copper ports with RJ-45 connectors that support the following speeds:</p> <ul style="list-style-type: none"> - 100M (requires AlliedWare Plus v5.4.9-0 or later.) - 1G/10G <p>Refer to “AT-XEM2-12XT Line Card” on page 69.</p>
AT-XEM2-12XTm	<p>12 copper ports with RJ-45 connectors that support the following speeds:</p> <ul style="list-style-type: none"> - 100M - 1G/2.5G/5G/10G <p>Refer to “AT-XEM2-12XTm Line Card” on page 71. (This card requires AlliedWare Plus v5.4.9-0 or later.)</p>

Table 22. XEM2 Ethernet Line Cards (Continued)

Line Card	Description
<p>AT-XEM2-12XS and AT-XEM2-12XS v2</p>	<p>12 ports that support the following types of transceivers:</p> <ul style="list-style-type: none"> - 1G SFP - 10G SFP+ - 10G one meter AT-SP10TW1, three meter AT-SP10TW3, and seven meter AT-SP10TW7 direct connect twinax cables (The AT-XEM2-12XS v2 Card does not support the AT-SP10TW7 cable.) <p>Refer to “AT-XEM2-12XS and AT-XEM2-12XS v2 Line Cards” on page 73.</p>
<p>AT-XEM2-4QS</p>	<p>Four ports that support the following types of transceivers:</p> <ul style="list-style-type: none"> - 40G QSFP+ transceivers - 40G QSFP+ direct connect cables - AT-QSFP-4SFP10G-3CU and AT-QSFP-4SFP10G-5CU 40G to 4x10G breakout cables <p>Refer to “AT-XEM2-4QS Line Card” on page 76.</p>
<p>AT-XEM2-1CQ</p>	<p>One port for the 100G QSFP28 transceiver or AT-QSFP28-1CU or AT-QSFP28-3CU direct attach cable. Refer to “AT-XEM2-1CQ Line Card” on page 78.</p>

- ❑ The AT-XEM2-8XSTm Card requires AlliedWare Plus v5.4.9-2 or later.
- ❑ The 100M port speed on the AT-XEM2-12XT Card requires AlliedWare Plus v5.4.9-0 or later.
- ❑ The AT-XEM2-12XTm Card requires AlliedWare Plus v5.4.9-0 or later.

For more information, refer to “Software and Hardware Releases” on page 59.

AT-XEM2-8XSTm Line Card

The AT-XEM2-8XSTm Line Card is shown in Figure 22.

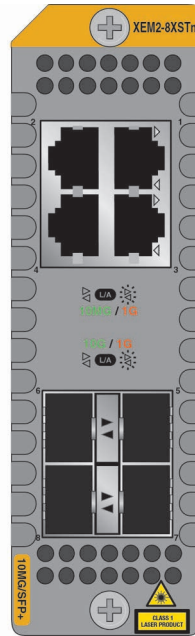

Figure 22. AT-XEM2-8XSTm Line Card

Copper Ports The AT-XEM2-8XSTm Card has four copper ports and four SFP ports. The specifications for the copper ports are listed in Table 23.

Table 23. Copper Ports on the AT-XEM2-8XSTm Line Card

Specification	Description
Port Speed	<p>The ports support the following speeds:</p> <ul style="list-style-type: none"> - 100M - 1G/2.5G/5G/10G <p>The ports do not support 10M.</p> <p>You can set port speed with Auto-Negotiation or manually. The default is Auto-Negotiation.</p>
Duplex Mode	Full-duplex only.

Table 23. Copper Ports on the AT-XEM2-8XSTm Line Card (Continued)

Specification	Description
Cabling	Minimum cable requirements are: <ul style="list-style-type: none"> - 100M - Standard TIA/EIA 568-B-compliant Category 3 unshielded cabling. - 1G/2.5G/5G - Standard TIA/EIA 568-A-compliant Category 5 or TIA/EIA 568-B-compliant Enhanced Category 5 (Cat 5e) unshielded cabling. - 10G -Standard TIA/EIA 568-C-compliant Category 6a unshielded cabling.
Maximum Distance	100 meters (328 feet)
Connector	8-pin RJ-45

Copper Port LEDs

Each port has a single LED that displays link and activity information. The states of LEDs are described in Table 24.

Table 24. Link and Activity LEDs for the Copper Ports on the AT-XEM2-8XSTm Line Card

State	Description
Solid Green	The port has established a 2.5G, 5G, or 10G link to a network device.
Flashing Green	The port is transmitting or receiving data at 2.5G, 5G, or 10G.
Solid Amber	The port has established a 100M or 1G link to a network device.
Flashing Amber	The port is transmitting or receiving data at 100M or 1G.

Table 24. Link and Activity LEDs for the Copper Ports on the AT-XEM2-8XSTm Line Card (Continued)

State	Description
Off	<p>Possible causes of this state are listed here:</p> <ul style="list-style-type: none"> - The port has not established a link with another network device. - The LEDs are turned off. To turn on the LEDs, use the eco-friendly button in the management panel or the NO ECOFRIENDLY LED command in the command line interface.

Transceiver Ports

The AT-XEM2-8XSTm Card also has four transceiver ports that support the following types of 1G SFP or 10G SFP+ transceivers:

- 1G SX or LX SFP fiber optic transceivers
- 10G SR or LR SFP+ fiber optic transceivers
- 10G one meter AT-SP10TW1 and three meter AT-SP10TW3 direct connect twinax cables, with SFP+ transceiver-style connectors

Note

The AT-XEM2-8XSTm Card does not support the seven meter AT-SP10TW7 direct connect cable.

Guidelines about the SFP+ transceiver ports are listed here:

- The ports do not support 100M transceivers.
- The ports support full-duplex mode only.
- You can set the port speeds with Auto-Negotiation or manually. The default is Auto-Negotiation.

SFP and SFP+ transceivers are purchased separately. For a list of supported transceivers, refer to the x950 Series data sheet on the Allied Telesis web site.

Transceiver Port LEDs

The ports have link and activity LEDs. The states of the LEDs are described in Table 25.

Table 25. Link and Activity LEDs for the SFP Ports on the AT-XEM2-8XSTm Line Card

State	Description
Solid Green	The transceiver in the slot has established a 10GBase link to a network device.
Flashing Green	The transceiver is transmitting or receiving data at 10GBase.
Solid Amber	The transceiver has established a 1GBase link to a network device.
Flashing Amber	The transceiver is transmitting or receiving data at 1GBase.
Off	<p>Possible causes of this state are listed here:</p> <ul style="list-style-type: none"> - The transceiver has not established a link with another network device. - The LEDs are turned off. To turn on the LEDs, use the eco-friendly button in the management panel or the NO ECOFRIENDLY LED command in the command line interface.

AT-XEM2-12XT Line Card

The AT-XEM2-12XT Line Card is shown in Figure 23.

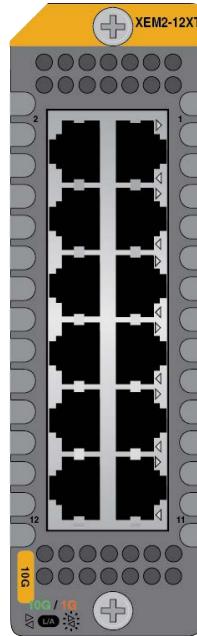

Figure 23. AT-XEM2-12XT Line Card

Copper Ports

The card has 12 copper ports with standard 8-pin RJ-45 ports. The specifications of the ports are listed in Table 26.

Table 26. Copper Ports on the AT-XEM2-12XT Line Card

Specification	Description
Port Speed	<p>The ports support the following speeds:</p> <ul style="list-style-type: none"> - 100M (Requires AlliedWare Plus v5.4.9-0 or later) - 1G/10G <p>The ports do not support 10M.</p>
Duplex Mode	Full-duplex only

Table 26. Copper Ports on the AT-XEM2-12XT Line Card (Continued)

Specification	Description
Cabling	<p>The minimum cable requirements are:</p> <ul style="list-style-type: none"> - 100M - Standard TIA/EIA 568-B-compliant Category 3 unshielded cabling. - 1G - Standard TIA/EIA 568-A-compliant Category 5 or TIA/EIA 568-B-compliant Enhanced Category 5 (Cat 5e) unshielded cabling. - 10G -Standard TIA/EIA 568-C-compliant Category 6a unshielded cabling.
Maximum Distance	100 meters (328 feet)
Connector	8-pin RJ-45

LEDs Each port has a single LED that displays link and activity information. Refer to Table 27.

Table 27. Port Link and Activity LEDs on the AT-XEM2-12XT Line Card

State	Description
Solid Green	The port has established a 10GBase link to a network device.
Flashing Green	The port is transmitting or receiving data at 10GBase.
Solid Amber	The port has established a 100M or 1GBase link to a network device.
Flashing Amber	The port is transmitting or receiving data at 100M or 1GBase.
Off	<p>Possible causes of this state are listed here:</p> <ul style="list-style-type: none"> - The port has not established a link with another network device. - The LEDs are turned off. To turn on the LEDs, use the eco-friendly button in the management panel or the NO ECOFRIENDLY LED command in the command line interface.

AT-XEM2-12XTm Line Card

The AT-XEM2-12XTm Card is shown in Figure 24.

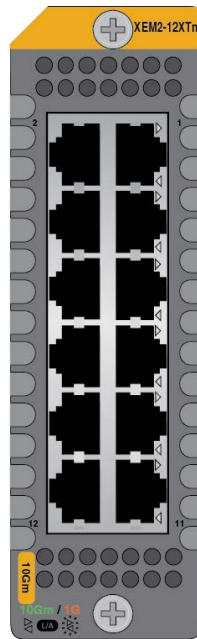

Figure 24. AT-XEM2-12XTm Line Card

Copper Ports

The AT-XEM2-12XTm Card has 12 copper ports with standard 8-pin RJ-45 ports. The specifications of the ports are listed in Table 28.

Table 28. Copper Ports on the AT-XEM2-12XTm Line Card

Specification	Description
Port Speed	<p>The ports support the following speeds:</p> <ul style="list-style-type: none"> - 100M - 1G/2.5G/5G/10G <p>The ports do not support 10M.</p> <p>You can set port speed with Auto-Negotiation or manually. The default is Auto-Negotiation.</p>
Duplex Mode	Full-duplex only.

Table 28. Copper Ports on the AT-XEM2-12XTm Line Card (Continued)

Specification	Description
Cabling	The minimum cable requirements are: <ul style="list-style-type: none"> - 100M - Standard TIA/EIA 568-B-compliant Category 3 unshielded cabling. - 1G/2.5G/5G - Standard TIA/EIA 568-A-compliant Category 5 or TIA/EIA 568-B-compliant Enhanced Category 5 (Cat 5e) unshielded cabling. - 10G -Standard TIA/EIA 568-C-compliant Category 6a unshielded cabling.
Maximum Distance	100 meters (328 feet)
Connector	8-pin RJ-45

LEDs Each port has a single LED that displays link and activity information. The states of LEDs are described in Table 29.

Table 29. Link and Activity LEDs on the AT-XEM2-12XTm Line Card

State	Description
Solid Green	The port has established a 2.5G, 5G, or 10G link to a network device.
Flashing Green	The port is transmitting or receiving data at 2.5G, 5G, or 10G.
Solid Amber	The port has established a 100M or 1GBase link to a network device.
Flashing Amber	The port is transmitting or receiving data at 100M or 1GBase.
Off	Possible causes of this state are listed here: <ul style="list-style-type: none"> - The port has not established a link with another network device. - The LEDs are turned off. To turn on the LEDs, use the eco-friendly button in the management panel or the NO ECOFRIENDLY LED command in the command line interface.

AT-XEM2-12XS and AT-XEM2-12XS v2 Line Cards

The AT-XEM2-12XS Line Card is shown in Figure 25.

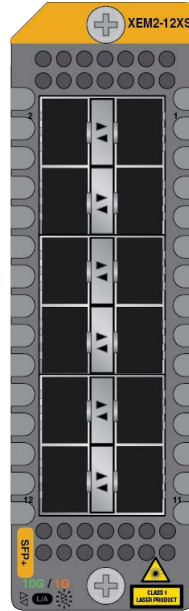

Figure 25. AT-XEM2-12XS Line Card

Transceiver Ports

The card has twelve ports that support the following types of 1G SFP, 10G SFP+, and 1G/2.5G/5G/10G transceivers with RJ-45 connectors:

- 1G SX or LX SFP transceivers
- 1G SPTX transceivers with RJ-45 ports for copper cable
- 10G SR or LR SFP+ fiber optic transceivers
- 10G one meter AT-SP10TW1, three meter AT-SP10TW3, and seven meter AT-SP10TW7 direct connect twinax cables with SFP+ transceiver-style connectors
- 1G/10G SP10T transceivers with copper RJ-45 ports cable
- 1G/2.5G/5G/10G SP10TM transceivers with copper RJ-45 ports

Note

The AT-XEM2-12XS v2 Card does not support the seven meter AT-SP10TW7 direct connect cable.

Guidelines about the ports are listed here:

- They do not support 100M transceivers.
- They support full-duplex mode only.

- ❑ You can set the port speeds with Auto-Negotiation or manually. The default is Auto-Negotiation.

SFP or SFP+ transceivers must be purchased separately. For a list of supported transceivers, refer to the x950 Switches data sheet on the Allied Telesis web site.

Card Versions

There are two versions of the AT-XEM2-12XS Line Card. Their names are “AT-XEM2-12XS” and “AT-XEM2-12XS v2.” Refer to Figure 26.



Figure 26. AT-XEM2-12XS and AT-XEM2-12XS v2 Line Cards

Note

The AT-XEM2-12XS v2 Line Card requires AlliedWare Plus v5.4.9-2 or later.

Note

Unless stated otherwise, the “AT-XEM2-12XS” model name in this manual refers to both cards.

LEDs

The ports have link and activity LEDs. The LED states are described in Table 30.

Table 30. Port Link and Activity LEDs on the AT-XEM2-12XS Line Card

State	Description
Solid Green	The transceiver has established a 10G link to a network device.
Flashing Green	The transceiver is transmitting or receiving data at 10G.
Solid Amber	The transceiver has established a 1G link to a network device.
Flashing Amber	The transceiver is transmitting or receiving data at 1G.

Table 30. Port Link and Activity LEDs on the AT-XEM2-12XS Line Card

State	Description
Off	Possible causes of this state are listed here: <ul style="list-style-type: none">- The transceiver has not established a link with another network device.- The LEDs are turned off. To turn on the LEDs, use the eco-friendly button in the management panel or the NO ECOFRIENDLY LED command in the command line interface.

AT-XEM2-4QS Line Card

The AT-XEM2-4QS Line Card is shown in Figure 27.

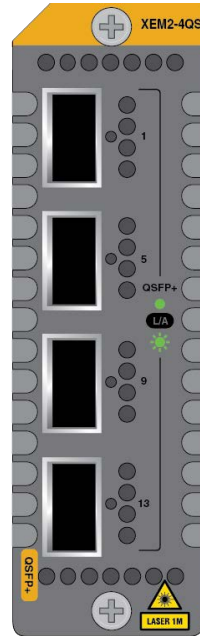

Figure 27. AT-XEM2-4QS Line Card

Transceiver Ports

Here are examples of the types of 40G QSFP+ transceivers supported by the line card:

- ❑ AT-QSFPSR4 transceiver - Maximum operating distance of 150 meters (492 feet) with 12-strand OM4 fiber optic cable.
- ❑ AT-QSFPLR4 transceiver - Operating range of 2 meters (6.6 feet) to 10 kilometers (6.2 miles) with single-mode fiber optic cable.
- ❑ AT-QSFP1CU and AT-QSFP3CU direct attach cables - Lengths of one and three meters, respectively.
- ❑ AT-QSFP-4SFP10G-3CU and AT-QSFP-4SFP10G-5CU 40G to 4x10G breakout cables in lengths of three and five meters, respectively. Refer to “Breakout Cables” on page 30 for more information.

LEDs The LED states for transceivers or direct attach cables in ports on the AT-XEM2-4QS Line Card are described in Table 31.

Table 31. Port Link and Activity Status LEDs on the AT-XEM2-4QS Line Card

State	Description
Solid Green	The transceiver has established a 40G link to a network device.
Flashing Green	The transceiver is transmitting or receiving data.
Off	<p>Possible causes of this state are listed here:</p> <ul style="list-style-type: none"> - The transceiver port is empty. - The transceiver has not established a link to a network device. - The LEDs are turned off. To turn on the LEDs, use the eco-friendly button in the management panel or the NO ECOFRIENDLY LED command in the command line interface.

The LED states for breakout cables are described in Table 32.

Table 32. Link and Activity Status LEDs for 10G Breakout Cables

State	Description
Solid Amber	At least one of the four ports on the breakout cable has established a 10G link to a network device.
Flashing Amber	At least one of the four ports on the breakout cable is sending or receiving data.
Off	<p>Possible causes of this state are listed here:</p> <ul style="list-style-type: none"> - The transceiver slot is empty. - None of the ports on the breakout cable have established a link to a network device. - The LEDs are turned off. To turn on the LEDs, use the eco-friendly button in the management panel or the NO ECOFRIENDLY LED command in the command line interface.

AT-XEM2-1CQ Line Card

The AT-XEM2-1CQ Line Card is shown in Figure 28.

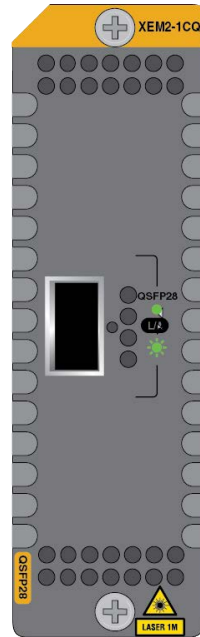

Figure 28. AT-XEM2-1CQ Line Card

Transceiver Port

Here are examples of the types of 100G QSFP28 transceivers supported by the line card:

- ❑ AT-QSFP28-SR4 transceiver - Maximum operating distance of 70m (230 ft) or 100m (328 ft) with 12-strand OM3 or OM4 fiber optic cable, respectively. Requires a MPO pluggable optical connector.
- ❑ AT-QSFP28-LR4 transceiver - Operating range of 2m (6.6 ft) to 10km (6.2 mi). Requires single-mode fiber optic cable with a duplex LC connector.
- ❑ AT-QSFP28-1CU and AT-QSFP28-3CU direct attach cables - Lengths of one and three meters, respectively.

LEDs The LED states for the port in the AT-XEM2-1CQ Line Card are described in Table 33 on page 79.

Table 33. Port Link and Activity Status LED on the AT-XEM2-1CQ Line Card

State	Description
Solid Green	The transceiver has established a 100G link to a network device.
Flashing Green	The transceiver is transmitting or receiving data.
Off	<p>Possible causes of this state are listed here:</p> <ul style="list-style-type: none"> - The transceiver slot is empty. - The transceiver has not established a link to a network device. - The LEDs are turned off. To turn on the LEDs, use the eco-friendly button in the management panel or the NO ECOFRIENDLY LED command in the command line interface.

Chapter 3

Virtual Chassis Stacking

The sections in this chapter are listed here:

- “Overview” on page 82
- “Stacking Guidelines” on page 83
- “Stack Trunks” on page 84
- “Master and Member Switches” on page 100
- “Switch ID Numbers” on page 101
- “Optional Feature Licenses” on page 102
- “Planning a Stack” on page 103
- “Stacking Worksheet” on page 104

Note

For more information on VCStack, refer to the *Stacking Introduction and Stacking Commands* chapters in the *Software Reference for x950 Series Switches, AlliedWare Plus Operating System* from www.alliedtelesis.com/support.

Overview

The Virtual Chassis Stacking (VCStack) feature enables you to link together up to eight x950 Switches into a virtual stack so that they function as a single networking unit. The feature provides the following benefits:

- ❑ Simplifies management - You can manage the devices as a single unit, rather than individually. Your local and remote management sessions automatically give you management access to all the switches.
- ❑ Reduces IP addresses - A stack requires only one IP address for remote management access, reducing the number of IP addresses you have to assign to network devices. The one address gives you management access to all the stack units.
- ❑ Adds feature flexibility and resiliency - Stacking gives you more flexibility in how you can configure some features. For instance, you can create port aggregations using ports from different switches, rather than ports from only one switch. By distributing the ports of an aggregation across multiple switches, you increase its resiliency because the aggregation can continue to function, though at a reduced bandwidth, even if a switch in a stack stops functioning.
- ❑ Reduces protocol requirements - Creating a stack might eliminate the need to configure some protocols, such as the Virtual Router Redundancy Protocol or Spanning Tree Protocol.

Stacking Guidelines

Here are general stacking guidelines:

- ❑ AlliedWare Plus v5.4.8-2 or later supports stacks of two switches.
- ❑ AlliedWare Plus v5.4.9 or later supports stacks up to four switches.
- ❑ AlliedWare Plus v5.4.9-2.3, v5.5.0 or later supports stacks up to eight switches.

Note

Instructions later in this guide explain how to view the version number of the operating software on the switches.

- ❑ A stack cannot have more than 320 ports.
- ❑ The VCStack feature comes standard with the AlliedWare Plus operating software. No additional software or license is required.
- ❑ The default setting for the VCStack feature on x950 Switches is disabled. Enabling it requires rebooting the switch. Instructions later in this guide explain how to enable the feature and reboot the unit.
- ❑ A stack can have AT-x950-28XSQ, AT-x950-28XTQm, AT-x950-52XSQ, and AT-x950-52XTQm Switches.
- ❑ The switches must have the same optional features licenses. If you purchased optional features for the switches, you should install them before assembling the stack.
- ❑ The switches of a stack have to be connected together with a network link called a stack trunk. As explained in “Stack Trunks” on page 84, you can choose any ports on the switches to be the trunk. Once ports are designated as members of the trunk, they cannot be used as regular networking ports.
- ❑ You should not pre-configure the features of the switches, such as virtual LANs and spanning tree, before building the stack. The configuration settings are likely to be discarded once the switches begin operating as a stack.

Stack Trunks

The switches of a stack are connected with a physical network link called the stack trunk. Here are general trunk guidelines:

- ❑ The ports of a trunk can be 10G, 40G, or 100G.
- ❑ A stack can have only one trunk.
- ❑ A trunk can have multiple physical links between switches, for added bandwidth and resiliency.
- ❑ All the ports in the trunk must be the same speed.
- ❑ There are no default trunk ports.
- ❑ You designate trunk ports with the STACKPORT command in the AlliedWare Plus operating system.
- ❑ Once ports are designated as trunk ports, you cannot view or change their parameter settings.
- ❑ The fiber optic transceivers or direct attach cables of a trunk must be from Allied Telesis. Transceivers or cables from other network equipment providers might not perform properly as trunks. For a list of supported transceivers, refer to the Allied Telesis web site.
- ❑ A stack of x950 Switches cannot include other stacking products, such as x600 Switches.
- ❑ In most cases, a trunk should have a minimum of two physical links between switches.
- ❑ If a trunk fails for any reason, the switches operate as stand-alone devices.

You can choose the ports of a trunk from the following groups on the x950 switches:

- ❑ “Ports 1 to 24 and Ports 1 to 48,” next
- ❑ “Ports 25 to 37 and Ports 49 to 61 with 40G Transceivers” on page 90
- ❑ “Ports 25 to 37 and Ports 49 to 61 with 100G Transceivers” on page 91
- ❑ “XEM2 Line Cards” on page 93

Ports 1 to 24 and Ports 1 to 48

Ports 1 to 24 on the AT-x950-28XSQ Switch and ports 1 to 48 on the AT-x950-52XSQ Switch support 1G SFP, 10G SFP+, and RJ45 transceivers, while ports 1 to 24 on the AT-x950-28XTQm Switch and ports 1 to 48 on the AT-x950-52XTQm Switch are copper ports that support 1G/2.5G/5G/10G. Even though the ports are different on these switches, the rules to using them as a stack trunk are mainly the same.

Here are the guidelines:

- ❑ The trunk can have up to eight ports per switch. The more ports in the trunk, the greater its bandwidth and resiliency.
- ❑ You can use any of the ports for the trunk.
- ❑ There are no default trunk ports.
- ❑ For the AT-x950-28XTQm and AT-x950-52XTQm Switches, any combination of two models can be in the stack.
- ❑ For the AT-x950-28XSQ and AT-x950-52XSQ models, any combination of two models can be in the stack.
- ❑ To build stacks with the AT-x950-28XTQm or AT-x950-52XTQm Switch and AT-x950-28XSQ or AT-x950-52XSQ Switch, use QSFP ports or XEM2 Line Cards on the AT-x950-28XSQ or AT-x950-28XTQm Switch, or QSFP ports on the AT-x950-52XSQ or AT-x950-52XTQm Switch.
- ❑ Ports 1 to 24 in the AT-x950-28XSQ Switch and ports 1 to 48 on AT-x950-52XSQ Switch support 1G, 2.5G, 5G, and 10G transceivers. However, the transceivers for the trunk must be 10G.
- ❑ For a stack of AT-x950-28XSQ and AT-x950-52XSQ Switches, the trunk can consist of either 10G fiber optic transceivers or, if the switches are in the same or adjacent equipment racks, SP10TW direct attach cables.
- ❑ Copper ports on the AT-x950-28XTQm and sAT-x950-52XTQm Switches support 1G/2.5G/5G/10G. Ports used in a trunk must operate at 10G, in Auto-Negotiation.
- ❑ In stacks of three or more switches, you have to connect the end switches together to form a ring.

The following guidelines are not mandatory but they are recommended because they can make managing or troubleshooting a trunk easier:

- ❑ Use the same ports for the trunk on all the switches.
- ❑ Choose consecutive ports (for example, ports 1 to 8).
- ❑ When cabling the trunk links, connect together the same ports in the switches, if possible.

Figure 29 on page 86 has examples of stacks of two, three, and four AT-x950-28XSQ Switches, with trunks of 10G links. Here are the general properties:

- ❑ The trunks consist of four 10G ports on each switch. (10G trunks can have up to eight ports per switch.)
- ❑ The switches use the same consecutive ports, 1 to 4. As mentioned earlier, the trunk ports do not have to be consecutive, nor do they have to be the same ports on all switches. But following the recommendations can make trunk management easier.

- ❑ In stacks of three or more switches, the top and bottom switches are connected together so that the trunk forms a ring.
- ❑ When possible, try cabling the same trunk ports together. For example, if you select ports 6 to 9 as trunk ports, cable port 6 on one switch to port 6 on the next, port 7 to port 7, and so on. Again, this is not mandatory, but it can make managing or troubleshooting the stack easier.

Stack of Two Switches

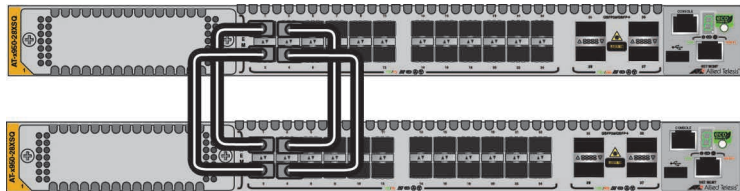

Stack of Three Switches

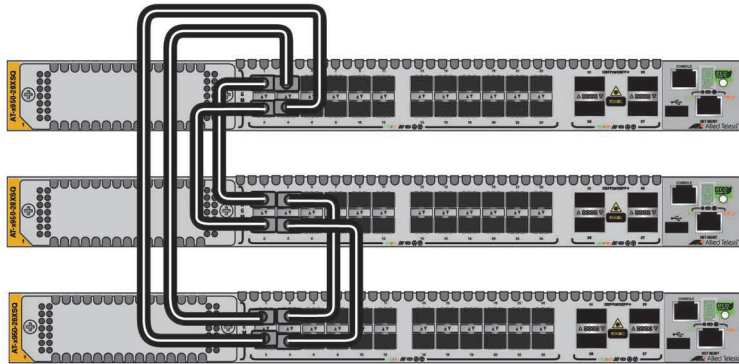

Stack of Four Switches

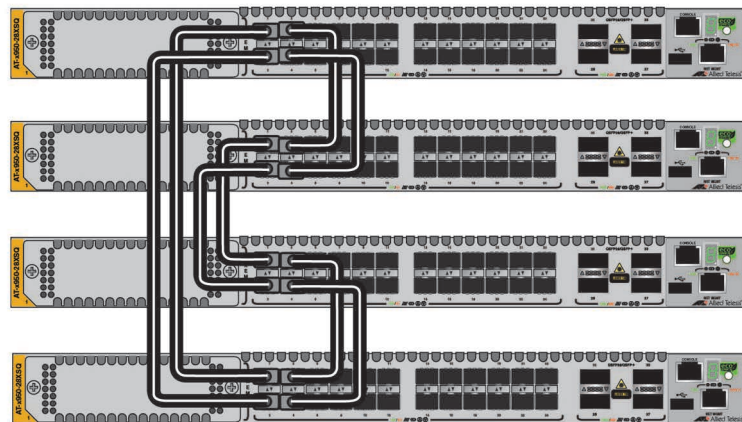
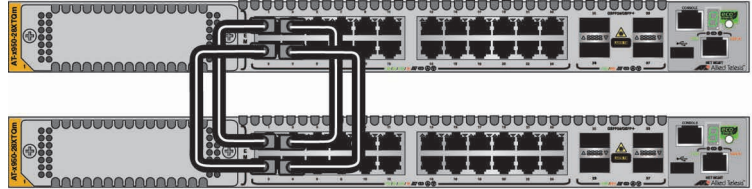

Figure 29. Example Stacks of AT-x950-28XSQ Switches with Trunks of 10G Ports

Figure 30 has examples of stacks with 10G trunks for two, three, and four AT-x950-28XTQm Switches. The examples use ports 1 to 4 for the trunks. As a reminder, a trunk of ports 1 to 24 can have up to eight ports per switch and you can use any of the ports.

Stack of Two Switches



Stack of Three Switches

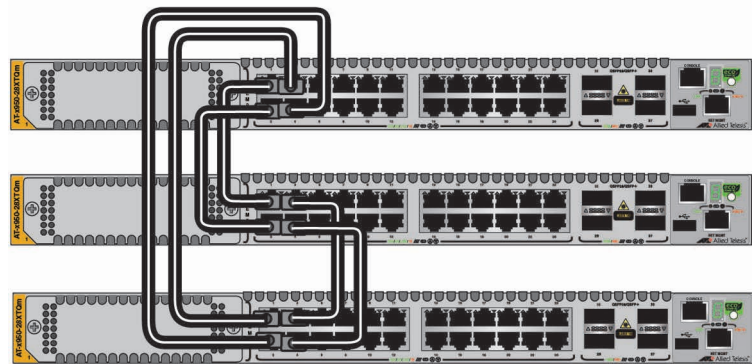

Stack of Four Switches

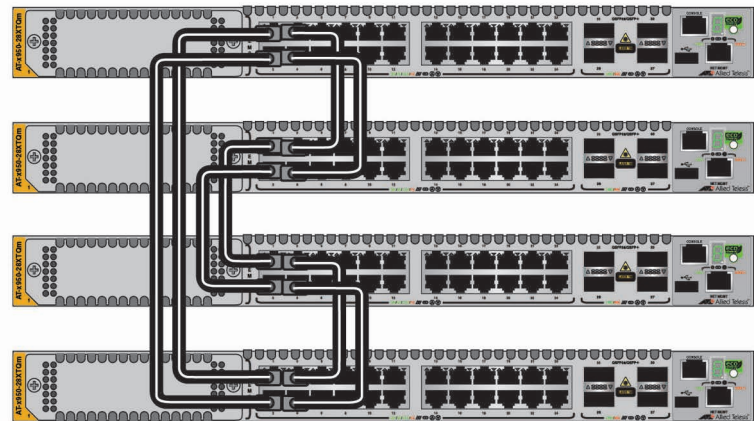
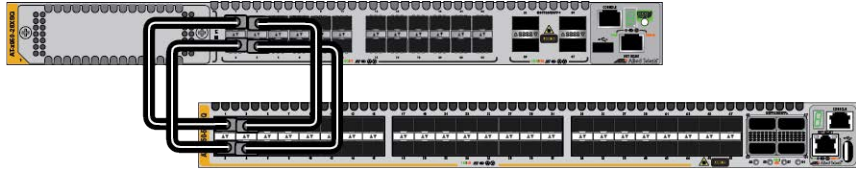

Figure 30. Example Stacks of AT-x950-28XTQm Switches with Trunks of 10G Ports

Figure 31 has examples of stacks with 10G trunks with combinations of two, three, or four AT-x950-28XSQ and AT-x950-52XSQ Switches. The examples use ports 1 to 4 for the trunks. As a reminder, a trunk of ports 1 to 24 on the AT-x950-28XSQ Switch and ports 1 to 48 on the AT-x950-52XSQ Switch can have up to eight ports per switch and you can use any of the ports.

Stack of Two Switches



Stack of Three Switches

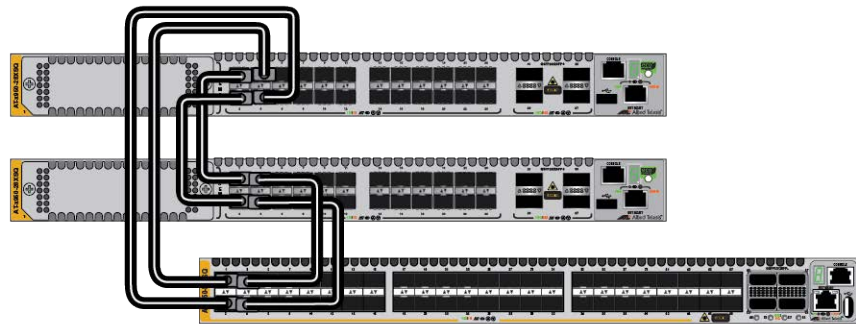

Stack of Four Switches

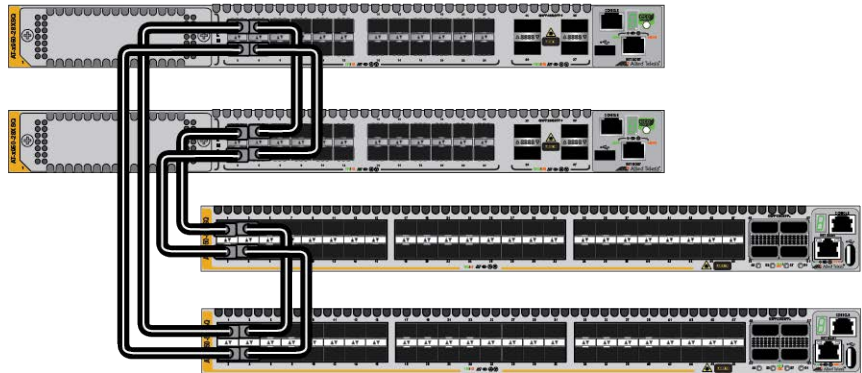

Figure 31. Example Stack Trunks of 10G Links on AT-x950-28XSQ and AT-x950-52XSQ Switches

Figure 32 has examples of stacks with 10G trunks with combinations of two, three, and four AT-x950-28XTQm and AT-x950-52XTQm Switches. The examples use ports 1 to 4 for the trunks. As a reminder, a trunk of ports 1 to 24 on the AT-x950-28XTQm Switch and ports 1 to 48 on the AT-x950-52XTQm Switch can have up to eight ports per switch and you can use any of the ports.

Stack of Two Switches



Stack of Three Switches

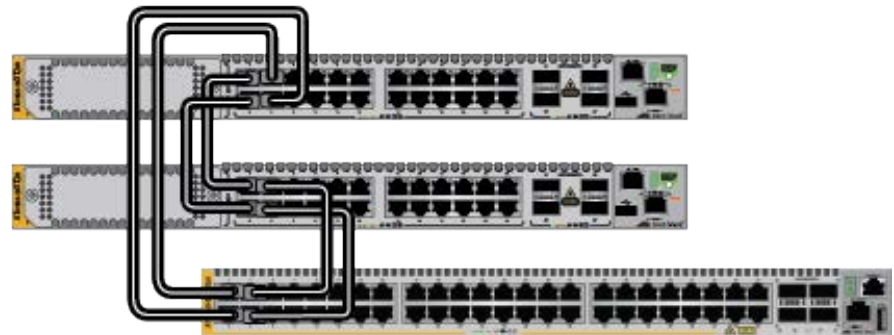

Stack of Four Switches

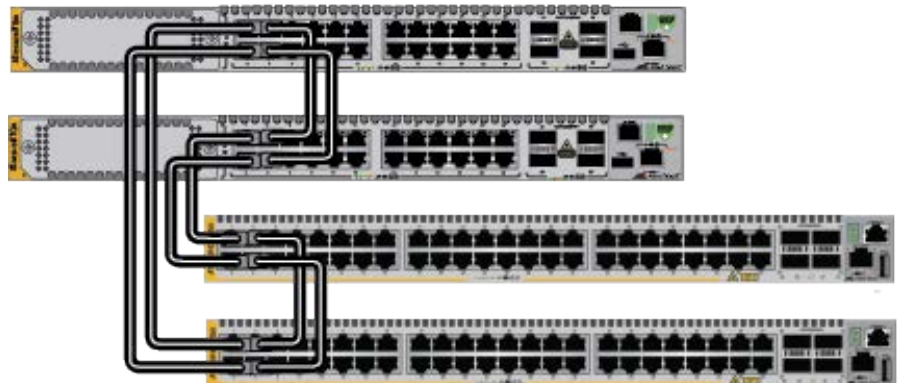

Figure 32. Example Stack Trunks of 10G Links on AT-x950-28XTQm and AT-x950-52XTQm Switches

Ports 25 to 37 and Ports 49 to 61 with 40G Transceivers

You can also use ports 25 to 37 on the AT-x950-28XSQ or AT-x950-28XTQm Switch and ports 49 to 61 on the AT-x950-52XSQ or AT-x950-52XTQm Switch for stack trunks. These ports support both 40G and 100G transceivers. You can use either type of transceivers for the trunk, but the rules are slightly different. Here are the guidelines to using 40G transceivers for the trunk:

- ❑ The trunk links can consist of fiber optic transceivers or QSFP1CU or QSFP3CU direct attach cables.
- ❑ Stacks can have any combination of AT-x950-28XSQ, AT-x950-28XTQm, AT-x950-52XSQ, or/and AT-x950-52XTQm Switches.
- ❑ For stacks of two switches, you can use two, three, or four ports per switch for trunks. Examples are show in Figure 33.

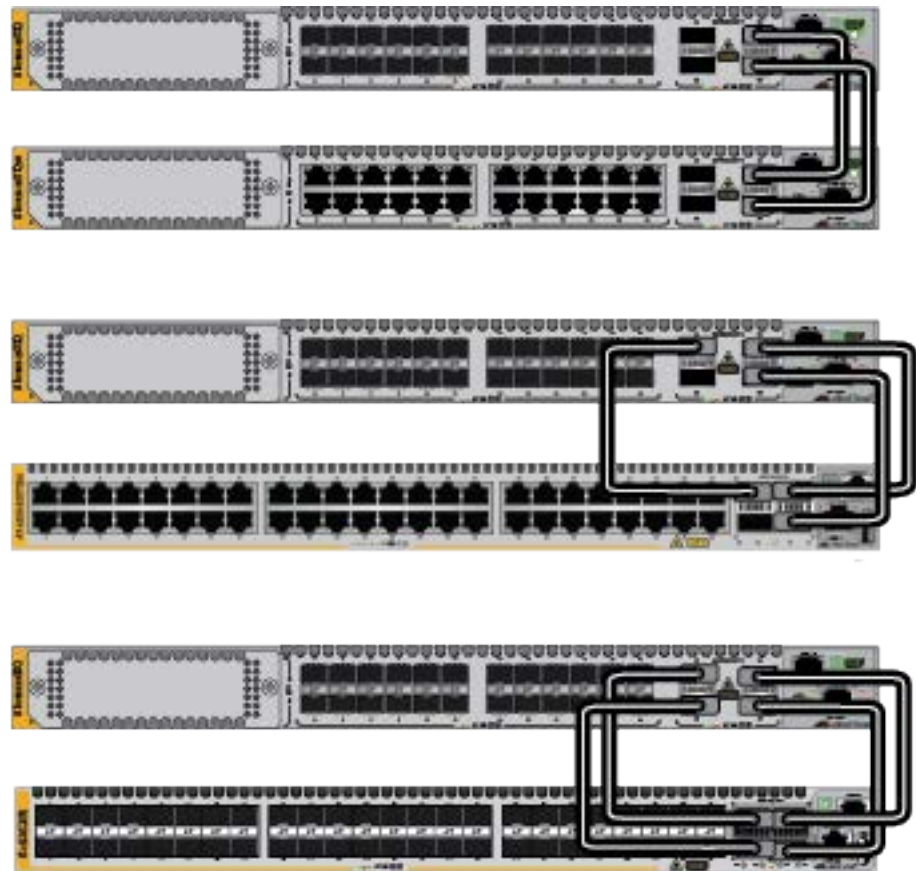

Figure 33. Stack Trunk Examples of Two Switches with Trunk 40G Links

- ❑ To build stacks of three or more switches, Allied Telesis recommends using all four ports. Examples are shown in Figure 34. Please note how the top and bottom switches are connected to form a loop in the trunk.

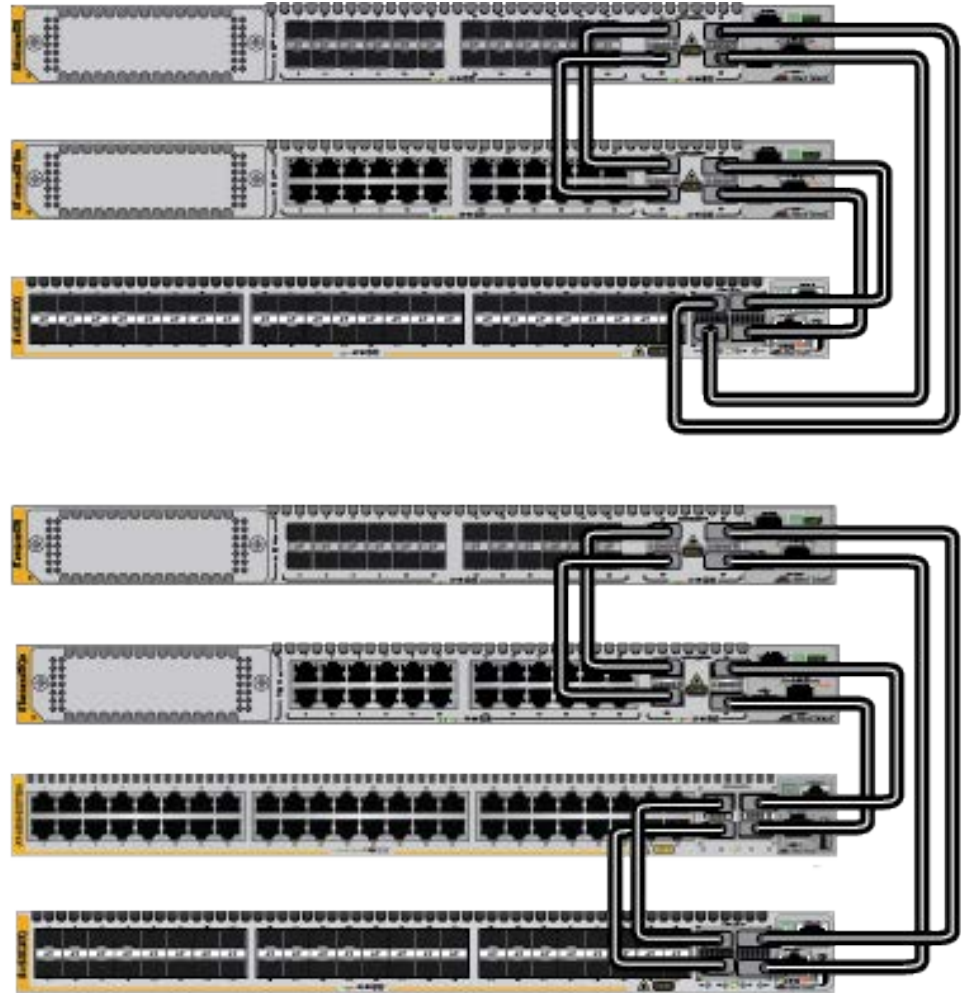

Figure 34. Stack Trunk Examples of Three or Four Switches with 40G Links

Ports 25 to 37 and Ports 49 to 61 with 100G Transceivers

Here are the guidelines to using ports 25 to 37 for the AT-x950-28XSQ or AT-x950-28XTQm Switch and ports 49 to 61 for the AT-x950-52XSQ or AT-x950-52XTQm Switch with 100G transceivers for trunks:

- ❑ You can use either fiber optic transceivers or QSFP28-1CU or QSFP28-3CU direct attach cables for the trunk links.
- ❑ The trunk can have a maximum of two ports per switch.
- ❑ You can use any two of the four 100G ports for the trunk.

- ❑ Because the trunk cannot have more than two 100G ports per switch, stacks of three or more switches can have only one link between switches.
- ❑ Stacks can have any combination of AT-x950-28XSQ, AT-x950-28XTQm, AT-x950-52XSQ, or/and AT-x950-52XTQm Switches.
- ❑ Figure 35 illustrates stacks of two, three, and four switches, with ports 33, 37, 57 and 61 and 100G links as the trunks.

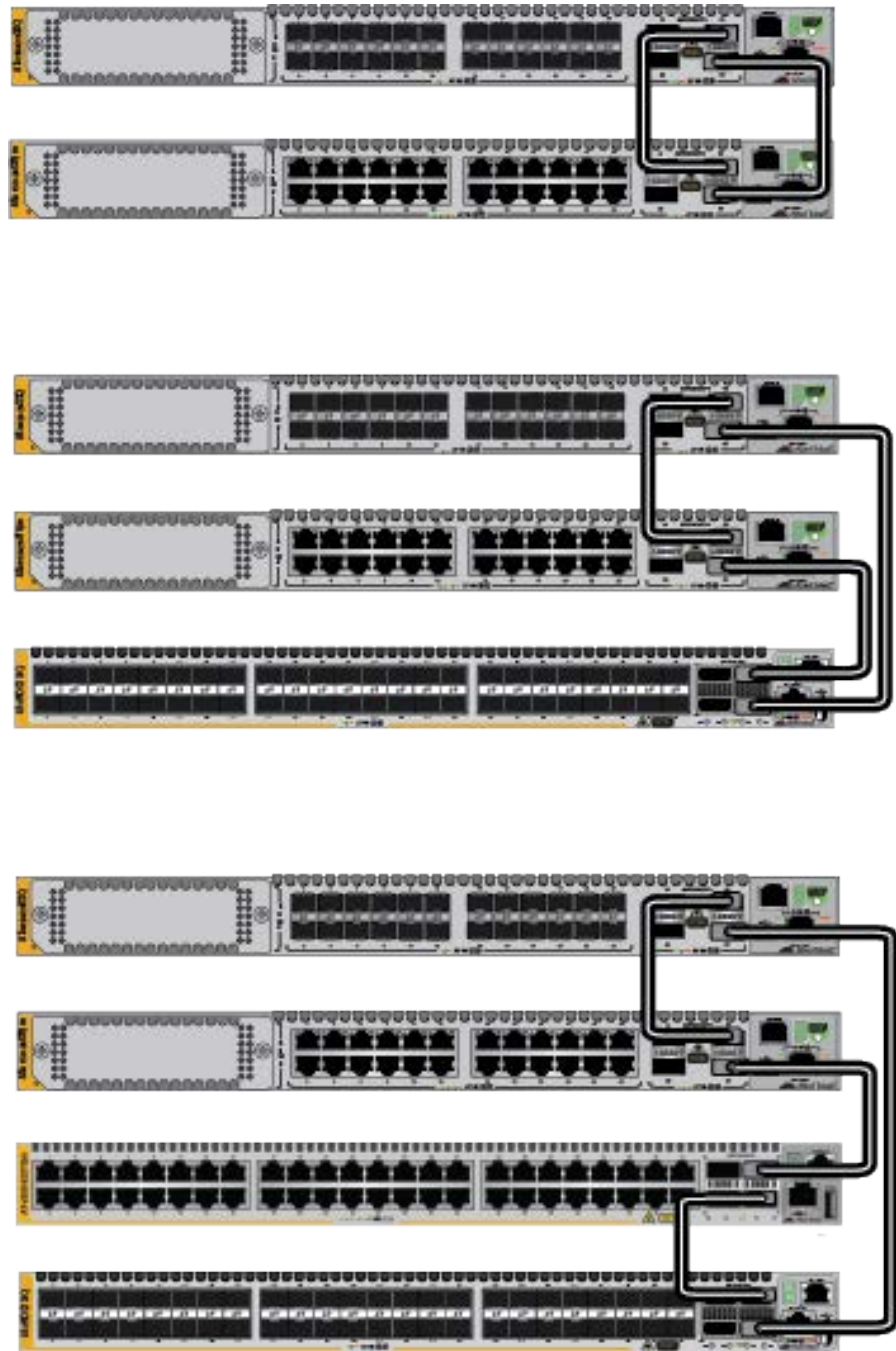

Figure 35. Stack Trunk Examples with 100G Links

XEM2 Line Cards

Here are the guidelines for using ports on XEM2 Line Cards in the expansion slots for trunks:

Note

The AT-x950-52XSQ and AT-x950-52XTQm Switches do not support XEM2 Line Cards.

- ❑ Stacks can have up to eight switches.
- ❑ Stacks can have both AT-x950-28XSQ and AT-x950-28XTQm Switches.
- ❑ The maximum number of links in the trunk varies by line card. Refer to Table 34. For example, a trunk using AT-XEM2-12XT or AT-XEM2-12XS Line Cards can have up to eight ports per card.

Table 34. Maximum Number of Trunk Ports Per Switch

XEM2 Series Line Cards	Maximum Number of Trunk Ports Per Switch	Guidelines
AT-XEM2-8XSTm	4	1, 2
AT-XEM2-12XT	8	1
AT-XEM2-12XTm	8	1
AT-XEM2-12XS and AT-XEM2-12XS v2	8	2
AT-XEM2-4QS	4	
AT-XEM2-1CQ	1	3

The guidelines are listed here:

1. Trunks of copper ports on AT-XEM2-8XSTm, AT-XEM2-12XT, and AT-XEM2-12XTm Line Cards have to operate at 10G. They cannot be used as trunk ports at lower speeds.
 2. Trunks of SFP+ ports on AT-XEM2-8XSTm, AT-XEM2-12XS, and AT-XEM2-12XS v2 Line Cards have to use 10G SFP+ transceivers. They cannot be used as trunk ports at lower speeds.
 3. Allied Telesis does not recommend using the AT-XEM2-1CQ Line Card for a stack trunk.
- ❑ Figure 36 on page 94 is an example of a stack of two switches with a trunk of six 10G links on AT-XEM2-12XT Line Cards.

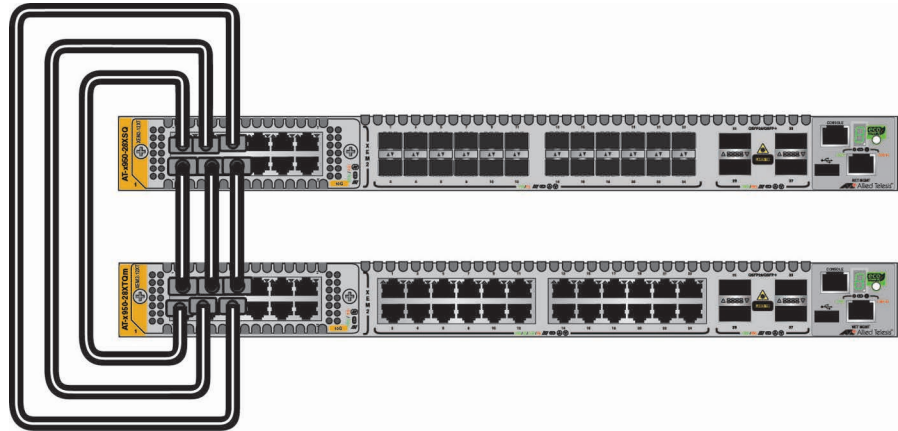

Figure 36. Example Trunk Using AT-XEM2-12XT Line Cards

- Figure 37 is an example of a stack of three switches with a trunk from ports on AT-XEM2-12XS Line Cards.

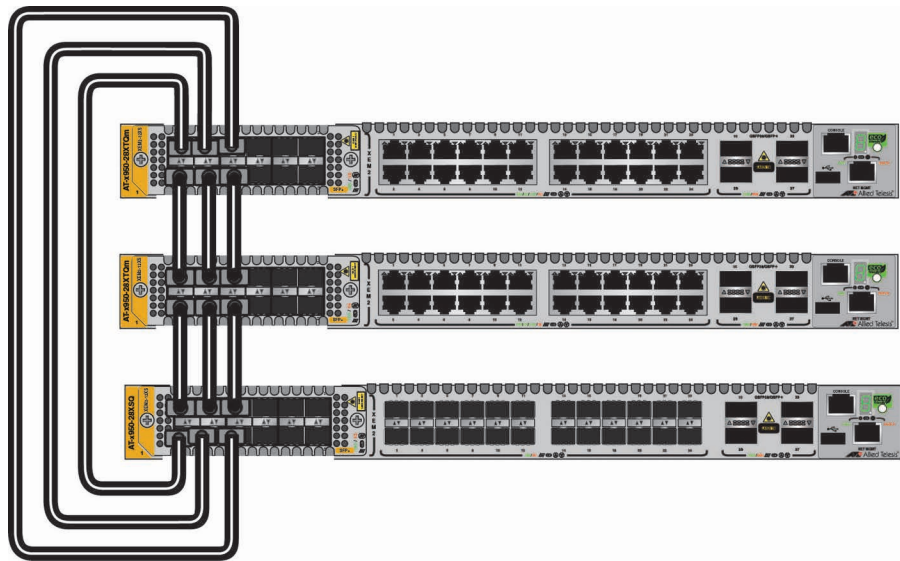

Figure 37. Example Trunk Using AT-XEM2-12XS Line Cards

- Figure 38 on page 95 is an example of a stack of four switches with a trunk of ports on AT-XEM2-4QS Line Cards.

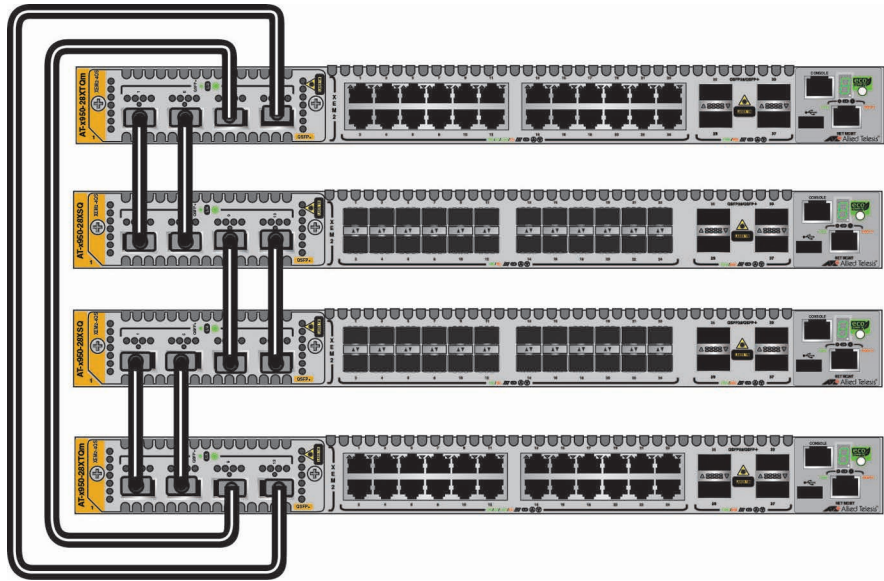

Figure 38. Example Trunk Using AT-XEM2-4QS Line Cards

Unsupported Trunks

The following are examples of unsupported trunks.

- ❑ In stacks of three or more switches, the number of links in the trunk has to be the same on all switches. The trunk in Figure 39 is unsupported because the middle switch is connected to the top and bottom switches with two links each, while the top and bottom switches are connected with only one link.

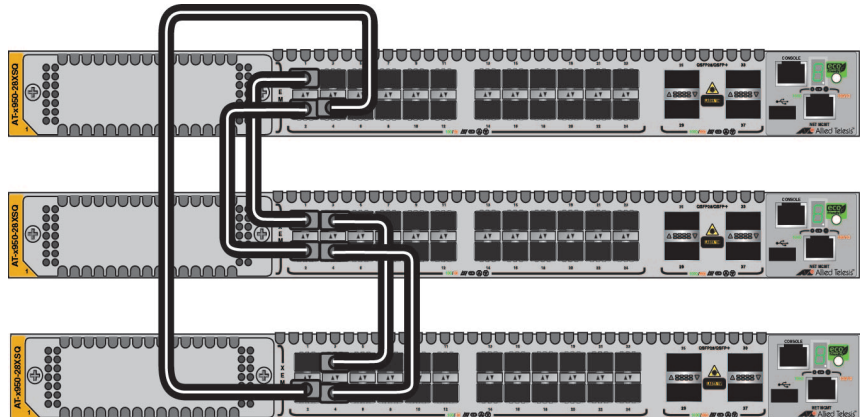

Figure 39. Unsupported Trunk with Different Numbers of Links Between Switches

- ❑ The cables in a trunk must be all the same type: They can be all fiber optic cables, direct attach cables, or copper cables. Trunks cannot contain different types of cables. The trunk in Figure 40 on page 96 is unsupported because it has both fiber optic and direct attach cables.

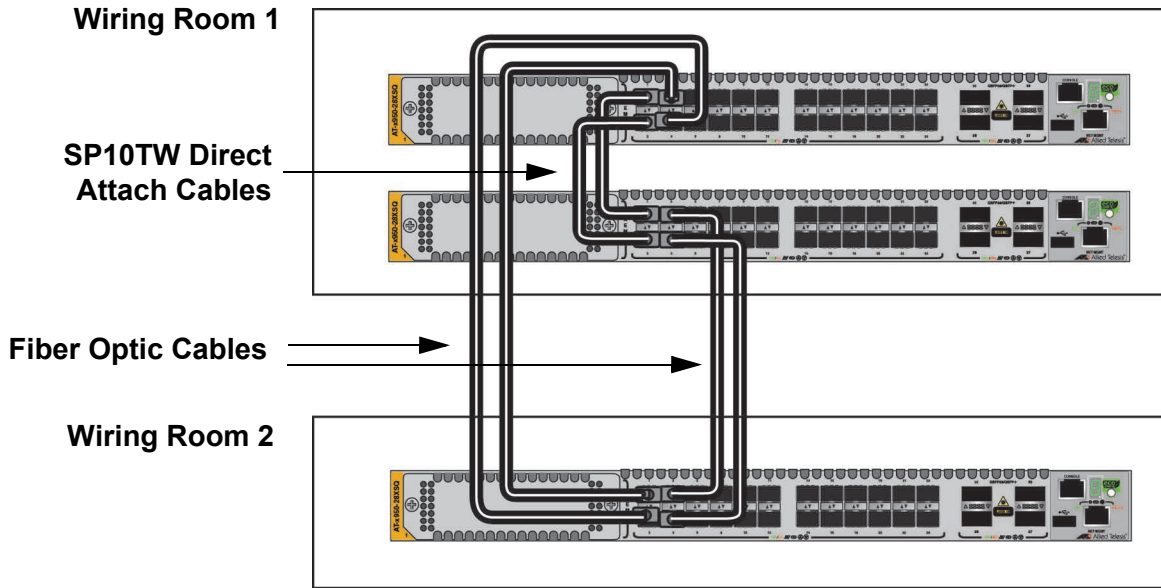

Figure 40. Unsupported Trunk with Mixed Cables

- ❑ Trunks cannot have both base ports and XEM2 Line Card ports. The unsupported trunk in Figure 41 consists of base 10G ports and ports on AT-XEM2-12XS Line Cards.

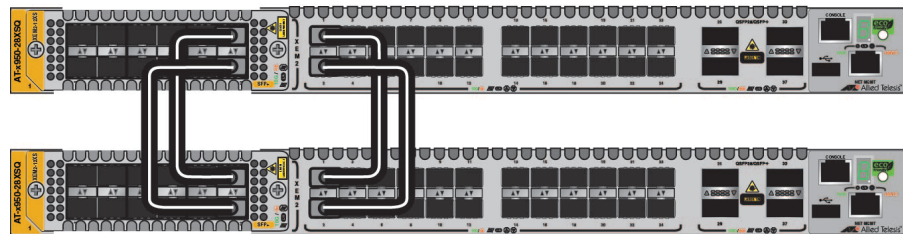

Figure 41. Unsupported Trunk with Both Base and XEM2 Line Card Ports

- ❑ Trunks cannot have links that interconnect base ports and XEM2 Line Card ports. The example trunk in Figure 42 is unsupported because base 10G ports 1 and 2 in the top switch are connected to ports 1 and 2 on the AT-XEM2-12XS Line Card in the bottom switch.

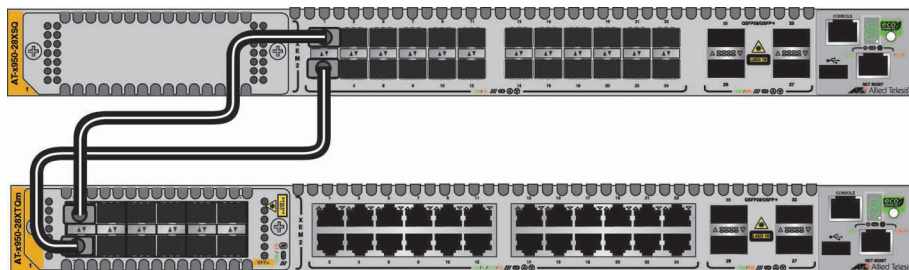

Figure 42. Unsupported Trunk of Connected Base and Line Card Ports

- ❑ In most cases, trunks should have a minimum of two links between switches. The trunk in Figure 43 is not recommended because there is only one link between switches. The exceptions to this are stacks of three or more switches with trunks of base 100G ports. Refer to Figure 35 on page 92.

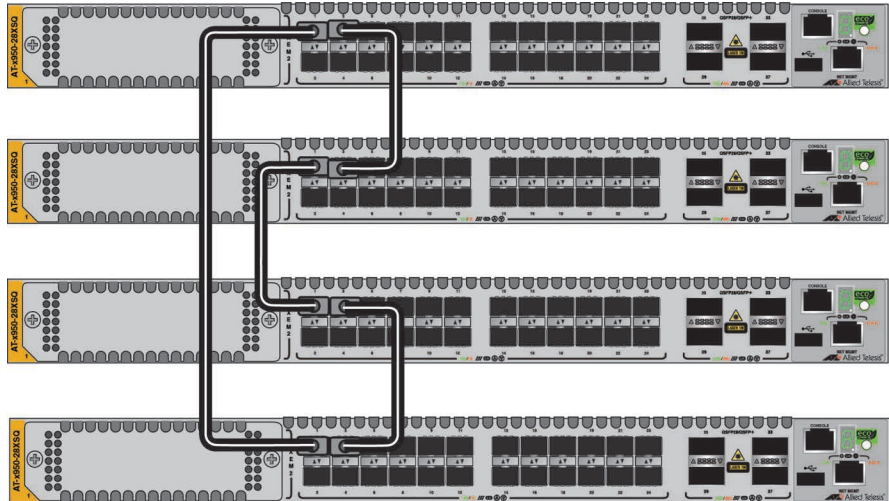

Figure 43. Unsupported Trunk with Only One Link Between Switches

- ❑ Trunk links must be the same speed. The example in Figure 44 is unsupported because the links are different speeds.

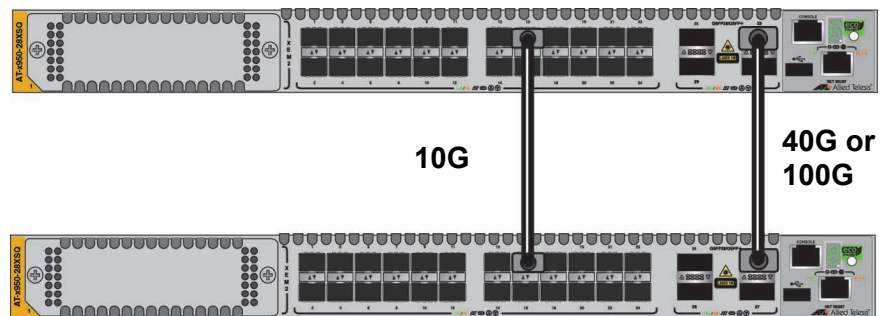

Figure 44. Unsupported Trunk with Different Port Speeds

- ❑ Allied Telesis does not recommend using the AT-XEM2-1CQ Line Card for a stack trunk because it has only one transceiver port and the switch has only one expansion port. Refer to Figure 45 on page 98. Instead, use two base 40/100G transceiver ports, as shown in Figure 35 on page 92, to build a 100G trunk.

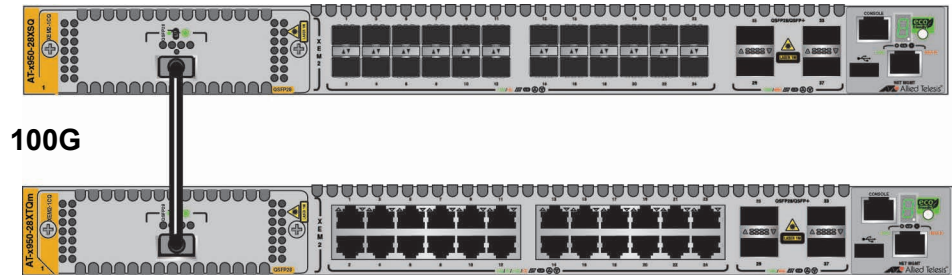

Figure 45. Not Recommended Stack Trunk of AT-XEM2-12XS Line Cards

- ❑ You cannot use a 10G breakout cable for a trunk. Refer to Figure 46.

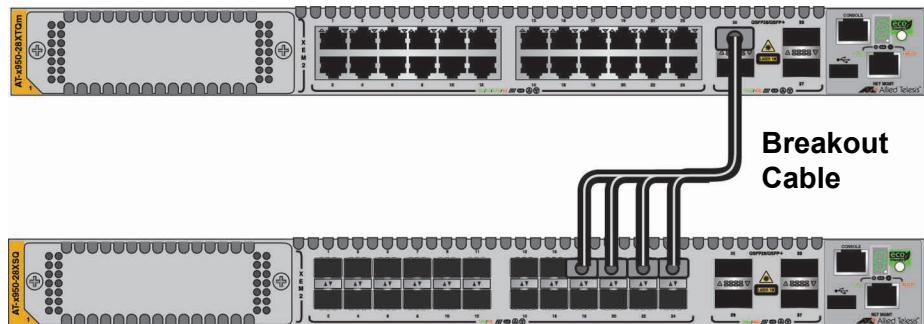
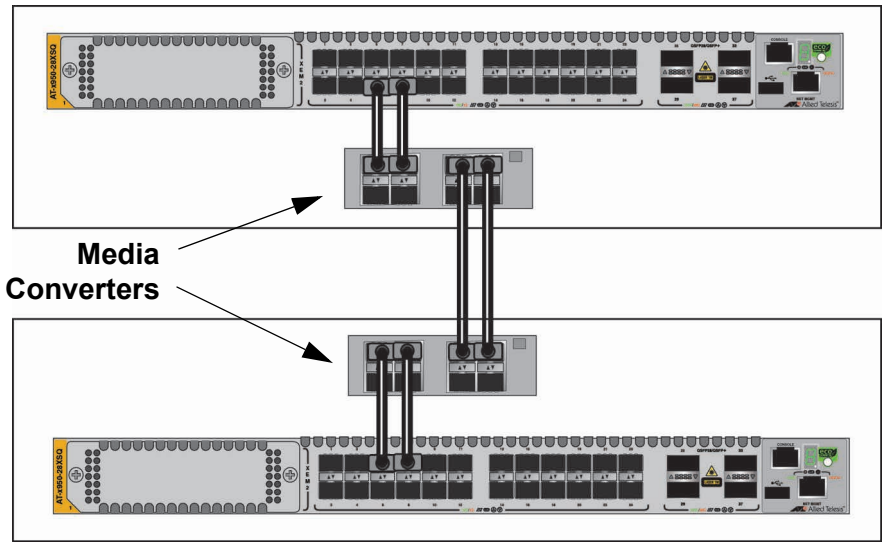

Figure 46. Unsupported Trunk with a 10G Breakout Cable

- ❑ The base 10G transceiver ports and AT-XEM2-12XS Line Card support 1G transceivers. However, you cannot use 1G transceivers for a stack trunk.
- ❑ Trunk links must be direct connections between ports on the switches, without any intermediary network devices, such as media converters, routers, or other Ethernet switches. Figure 47 on page 99 is an example of an unsupported trunk because it contains media converters.

Wiring closet 1



Wiring closet 2

Figure 47. Unsupported Trunk with Intermediary Network Devices

Master and Member Switches

One switch of a stack functions as a master switch. Its main functions are listed here:

- ❑ Coordinate and monitor stack operations.
- ❑ Verify that the switches are using the same version of management software. It automatically downloads its management software over the stacking cables to switches with different software versions.
- ❑ Verify that the switches have different ID numbers. It automatically assigns new ID numbers to resolve conflicts where two or more switches have the same ID number.

The other switches are called member switches.

Selection of the Master Switch

The switches of the stack designate the master switch during the initialization process, when they are powered on or reset. They base the selection of the master switch on the following parameters:

- ❑ Stack priority numbers
- ❑ MAC addresses

The stack priority number is an adjustable value of 0 to 255, where the lower the number, the higher the priority. Typically, the switch with the lowest priority number (highest priority) becomes the master switch of a stack. The default priority value is 128.

If the switches have the same priority values, the selection of the master switch is based on their MAC addresses. As with the priority value, the lower the MAC address, the higher the priority. The switch with the lowest MAC address becomes the master switch.

If you power on the stack without adjusting the priority values, the master switch is selected based on the MAC addresses if the units are powered on simultaneously. If you power on the switches one at a time, the master switch is the first switch powered on.

Switch ID Numbers

Each switch must have an ID number. The range is 1 to 8. The default is 1. The ID numbers are displayed on the ID LEDs on the front panels of the units. You can assign the numbers yourself or let the master switch assign the numbers automatically when you first power on the stack.

You use the ID numbers to identify the individual ports and switches when configuring the devices with the commands in the management software. For further information, refer to “Designating Ports in the Command Line Interface” on page 54.

The ID numbers are also used to identify the parameter settings that are stored in the configuration file. When the stack is reset or power cycled, the switches use the ID numbers in the commands in the configuration file to determine which parameter settings belong to which switch.



Caution

You should not change the ID numbers of the switches after you begin configuring the parameter settings. Otherwise, the stack might apply parameter settings to the wrong devices when you reset or power cycle it. *See* E79

The switches do not use the ID numbers to select the master switch. The selection of the master switch is based on the priority numbers and MAC addresses, as previously explained.

Optional Feature Licenses

The x950 Switch comes with the AlliedWare Plus management software and a base set of features that are available as soon as you install the device. Additional features and capabilities might be included with the operating system, but can be access only after they are unlocked with optional feature licenses from Allied Telesis. Contact your authorized reseller or distributor for a list of optional features licenses for this product.

Here are the guidelines to feature licenses for a stack of x950 Switches:

- ❑ The VCStack feature is part of the base features of the switch. It does not require an optional feature license.
- ❑ You can install feature licenses while the switches are operating as stand-alone units or as a stack.
- ❑ When ordering feature licenses for the switches of a stack, you must order one license for each switch.
- ❑ Switches can form a stack even if they have different feature licenses. However, the additional features are only available on those switches with the licenses. The stack generates a warning message if it detects that the switches do not have the same optional feature licenses.

Planning a Stack

Here are questions you need to answer before building or configuring a stack:

- ❑ How many switches will be in the stack? AlliedWare Plus v5.4.8-2 supports stacks of two switches. AlliedWare Plus v5.4.9 or later supports stacks up to four switches. AlliedWare Plus v5.4.9-2.3 or later supports stacks up to eight switches.
- ❑ Which switch will be the master switch? Refer to “Master and Member Switches” on page 100. It can be any switch.
- ❑ Which ports will be the trunk ports on the switches? Refer to “Stack Trunks” on page 84.
- ❑ What will be the ID numbers of the member switches? Refer to “Switch ID Numbers” on page 101. The master switch should be given ID 1, the default value. Member switches should be assigned IDs in the range of 2 to 8.
- ❑ If you are planning to use ports on XEM2 Line Cards for the stack trunk, have you already installed the cards in the switches? Refer to “Installing XEM2 Ethernet Line Cards” on page 141.
- ❑ What types of transceivers will be used in ports 25, 29, 33, and 37 on the AT-x950-28XSQ or AT-x950-28XTQm Switch, or ports, 49, 53, 57, and 61 on the AT-x950-52XSQ or AT-x950-52XTQm Switch in the master and member switches? Refer to “Ports for 40G QSFP+ and 100G QSFP28 Transceivers, and Breakout Cables” on page 30. You may install the transceivers (but not cable them) before configuring the switches for stacking.
- ❑ Have you already connected network cables to the trunk ports? If so, you should disconnect them before configuring the switches for stacking.

Note

Cabling the trunk ports before activating and configuring the VCStack feature may result in loops in your network topology, which can cause poor network performance.

Stacking Worksheet

The worksheet in Table 35 is here to assist you in configuring and maintaining a stack.

Table 35. Stacking Worksheet

Switch	Switch/ Location	Switch ID	Priority	Firmware Version Number ¹	Trunk Ports	Transceivers in Ports 25 to 37 or Ports 49 to 61 ²	XEM2 Card
Master		1	1			25 or 49: 29 or 53: 33 or 57: 37 or 61:	
Member		2	2			25 or 49: 29 or 53: 33 or 57: 37 or 61:	
Member		3	3			25 or 49: 29 or 53: 33 or 57: 37 or 61:	
Member		4	4			25 or 49: 29 or 53: 33 or 57: 37 or 61:	
Member		5	5			25 or 49: 29 or 53: 33 or 57: 37 or 61:	
Member		6	6			25 or 49: 29 or 53: 33 or 57: 37 or 61:	
Member		7	7			25 or 49: 29 or 53: 33 or 57: 37 or 61:	
Member		8	8			25 or 49: 29 or 53: 33 or 57: 37 or 61:	

1. AlliedWare Plus version number.

2. Use ports 25 to 37 for the AT-x950-28XSQ and AT-x950-28XTQm Switches, and ports 49 to 61 for the AT-x950-52XSQ and AT-x950-52XTQm Switches.

The worksheet columns are described in Table 36.

Table 36. Stacking Worksheet Columns

Column	Description
Location	Use this column to record the model names and physical locations of the switches, such as their buildings or equipment rooms. The information can be useful in identifying and locating the switches if they are in different locations.
ID	Each switch in a stack has to have a unique ID number in the range of 1 to 8. They display their numbers on the ID LEDs on the front panels. You use the numbers to identify the devices when you configure their ports. Allied Telesis recommends assigning the ID 1, the default value, to the master switch. You should decide on the ID assignments of the switches before beginning the configuration procedures.
Priority	<p>When the switches of a stack are reset or powered on, they perform an initialization process that involves, in part, choosing the master switch. The selection is based on their priority numbers and MAC addresses. The former is an adjustable parameter with a range of 0 to 255 and a default value of 128. The lower the value, the higher the priority. Thus, the switch with the lowest value becomes the stack master.</p> <p>If switches have the same priority number, the master is selected based on their MAC addresses. Again, as with priority numbers, the lower the MAC address, the higher the priority.</p> <p>Allied Telesis recommends setting each switch's priority value to match its ID value. This is to ensure that the switch you have chosen to be the master unit will function in that role. It will also make it possible for you to know the order in which the switches assume the master role if the primary master should fail or be powered off.</p>

Table 36. Stacking Worksheet Columns (Continued)

Column	Description
Firmware Version Number	Use this column to record the version numbers of the AlliedWare Plus management software on the switches. The switches might not be able to form the stack if they have different versions. Switches that have different versions should be updated to the most recent release before you build the stack. The configuration instructions explain how to view the version numbers.
Trunk Ports	Use this column to enter the trunk ports. You should choose the ports before beginning the configuration procedures. Refer to “Stack Trunks” on page 84.
Transceivers in Ports 25 to 37 or Ports 49 to 61	<p>Used this column to record the transceiver speeds in ports 25 to 37 or 49 to 61.</p> <hr/> <p>Note Use ports 25 to 37 for the AT-x950-28XSQ and AT-x950-28XTQm Switches, and ports 49 to 61 for the AT-x950-52XSQ and AT-x950-52XTQm Switches.</p> <hr/> <p>The possible speeds are listed here:</p> <ul style="list-style-type: none"> - 40G - 100G - 10G breakout cable
XEM2 Slot	<p>Use this column to enter the model names of the XEM2 Line Cards in the expansion slots of the AT-x950-28XSQ and AT-x950-28XTQm Switches.</p> <hr/> <p>Note The AT-x950-52XSQ and AT-x950-52XTQm Switches do not support XEM2 Line Cards.</p> <hr/>

Table 37 is an example of a completed worksheet for planning a stack with four switches.

Table 37. Example of a Completed Stack Worksheet

Switch	Switch/ Location	Switch ID	Prior- ity	Firmware Version Number	Trunk Ports	Transceivers in Ports 25 to 37 or Ports 49 to 61	XEM2 Card
Master	AT-x950- 28XSQ Bldg 2A rm:304	1	1	v5.4.9-0	33, 37	25 or 49 : empty 29 or 53 : 40G 33 or 57 : 100G 37 or 61 : 100G	none
Member	AT-x950- 28XTQm Bldg 2A rm:304	2	2	v5.4.9-0	33, 37	25 or 49 : 40G 29 or 53 : 40G 33 or 57 : 100G 37 or 61 : 100G	AT-XEM2- 12XS
Member	AT-x950- 28XTQm Bldg 2A rm:304	3	3	v5.4.9-0	33, 37	25 or 49 : 10G Breakout 29 or 53 : Empty 33 or 57 : 100G 37 or 61 : 100G	AT-XEM2- 4QS
Member	AT-x950- 52XSQ Bldg 2A rm:304	4	4	v5.5.0-1	57, 61	25 or 49 : 10G Breakout 29 or 53 : 100G 33 or 57 : 100G 37 or 61 : 100G	none
Member	N/A	N/A	N/A	N/A	N/A	N/A	
Member	N/A	N/A	N/A	N/A	N/A	N/A	
Member	N/A	N/A	N/A	N/A	N/A	N/A	
Member	N/A	N/A	N/A	N/A	N/A	N/A	

Chapter 4

Beginning the Installation

The chapter contains the following sections:

- ❑ “Reviewing Safety Precautions” on page 110
- ❑ “Installation Options” on page 115
- ❑ “Choosing a Site for the Chassis” on page 116
- ❑ “Unpacking the Switch” on page 117
- ❑ “Verifying the Accessory Kit” on page 121
- ❑ “Unpacking PWR600 AC and DC Power Supplies” on page 123

Reviewing Safety Precautions

Please review the following safety precautions before beginning the installation procedure.

Note

Safety statements that have the  symbol are translated into multiple languages in the *Translated Safety Statements* document at www.alliedtelesis.com/support.



Warning

Class 1 Laser product.  L1



Warning

Laser Radiation.
Class 1M Laser product.



Warning

Do not stare into the laser beam.  L2



Warning

Do not look directly at the fiber optic ends or inspect the cable ends with an optical lens.  L6



Warning

To prevent electric shock, do not remove the cover. No user-serviceable parts inside. This unit contains hazardous voltages and should only be opened by a trained and qualified technician. To avoid the possibility of electric shock, disconnect electric power to the product before connecting or disconnecting the LAN cables.
 E1



Warning

Do not work on equipment or cables during periods of lightning activity.  E2

**Warning**

Power cord is used as a disconnection device. To de-energize equipment, disconnect the power cord. ⚡ E3

**Warning**

Class I Equipment. This equipment must be earthed. The power plug must be connected to a properly wired earth ground socket outlet. An improperly wired socket outlet could place hazardous voltages on accessible metal parts. ⚡ E4

Note

Pluggable Equipment. The socket outlet shall be installed near the equipment and shall be easily accessible. ⚡ E5

**Caution**

Air vents must not be blocked and must have free access to the room ambient air for cooling. ⚡ E6

**Warning**

Operating Temperatures. This product is designed for a maximum ambient temperature of 50° degrees C. ⚡ E52

Note

All Countries: Install product in accordance with local and National Electrical Codes. ⚡ E8

**Warning**

Do not strip more than the recommended amount of wire. Stripping more than the recommended amount can create a safety hazard by leaving exposed wire on the terminal block after installation. ⚡ E10

**Warning**

When installing this equipment, always ensure that the frame ground connection is installed first and disconnected last. ⚡ E11



Warning

Only trained and qualified personnel are allowed to install or replace this equipment. ⚡ E14



Warning

The equipment must be earthed. The ground screw on the unit must be connected to a properly earthed bonding point. ⚡ E120



Caution

Circuit Overloading: Consideration should be given to the connection of the equipment to the supply circuit and the effect that overloading of circuits might have on overcurrent protection and supply wiring. Appropriate consideration of equipment nameplate ratings should be used when addressing this concern. ⚡ E21



Caution

Risk of explosion if battery is replaced by an incorrect type. Replace only with the same or equivalent type recommended by the manufacturer. Dispose of used batteries according to the manufacturer's instructions.

Attention: Le remplacement de la batterie par une batterie de type incorrect peut provoquer un danger d'explosion. La remplacer uniquement par une batterie du même type ou de type équivalent recommandée par le constructeur. Les batteries doivent être éliminées conformément aux instructions du constructeur. ⚡ E22



Warning

Mounting of the equipment in the rack should be such that a hazardous condition is not created due to uneven mechanical loading. ⚡ E25



Warning

The chassis may be heavy and awkward to lift. Allied Telesis recommends that you get assistance when mounting the chassis in an equipment rack. ⚡ E28

Note

Use dedicated power circuits or power conditioners to supply reliable electrical power to the device. ⚡ E27

**Warning**

This unit might have more than one power cord. To reduce the risk of electric shock, disconnect all power cords before servicing the unit. ⚡ E30

Note

If installed in a closed or multi-unit rack assembly, the operating ambient temperature of the rack environment may be greater than the room ambient temperature. Therefore, consideration should be given to installing the equipment in an environment compatible with the manufacturer's maximum rated ambient temperature (T_{mra}). ⚡ E35

**Caution**

Installation of the equipment in a rack should be such that the amount of air flow required for safe operation of the equipment is not compromised. ⚡ E36

**Warning**

Reliable earthing of rack-mounted equipment should be maintained. Particular attention should be given to supply connections other than direct connections to the branch circuits (e.g., use of power strips). ⚡ E37

**Warning**

This product may have multiple AC power cords installed. To de-energize this equipment, disconnect all power cords from the device. ⚡ E41

**Caution**

An Energy Hazard exists inside this equipment. Do not insert hands or tools into open chassis slots or plugs. ⚡ E44



Warning

This equipment shall be installed in a Restricted Access location.
E45



Caution

The unit does not contain serviceable components. Please return damaged units for servicing. E42



Warning

The temperature of an operational SFP or SFP+ transceiver may exceed 70° C (158° F). Exercise caution when removing or handling transceivers with unprotected hands. E43



Warning

The AC power supply unit must be connected to a grounded three wire AC source through the power supply cord. E127

Installation Options

Here are installation options for the x950 Switches:

- ❑ The AT-x950-28XSQ and AT-x950-28XTQm Switches support the XEM2 Line Cards. Refer to “Installing XEM2 Ethernet Line Cards” on page 141.
- ❑ The switch has four orientation options. Refer to Figure 48.

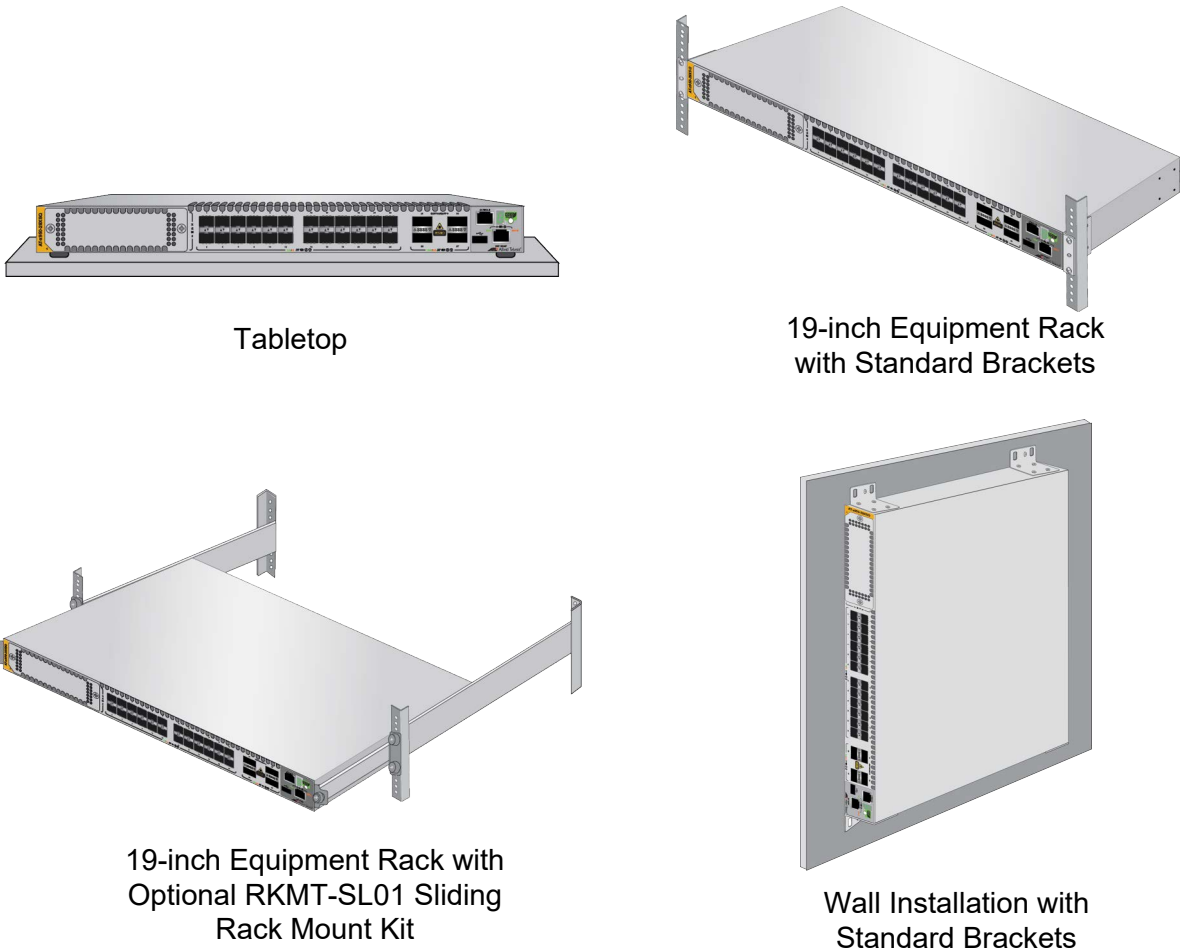

Figure 48. Installation Options

- ❑ The switch can be installed in an equipment rack with the RKMT-SL01 sliding rack mount kit. Refer to Chapter 9, “Installing the Switch in the RKMT-SL01 Sliding Rack” on page 173.

Note

The standard brackets are included with the switch, The optional RKMT-SL01 Sliding Shelf is purchased separately.

Choosing a Site for the Chassis

Observe these site requirements.

- ❑ If you are installing the device in an equipment rack, check that the rack is safely secured so that it will not tip over. Devices should be installed in the rack starting at the bottom, with the heavier devices near the bottom of the rack.
- ❑ The power outlet should be located near the chassis and be easily accessible.
- ❑ The site should allow for easy access to the ports on the front of the switch, so that you can easily connect and disconnect cables, and view the port LEDs.
- ❑ The site should allow for adequate air flow around the unit and through the cooling vents on the front and rear panels. (The ventilation direction is from front to back, with the fans on the back panel drawing the air out of the unit.)
- ❑ The site should not expose the switch to moisture or water.
- ❑ The site should be a dust-free environment.
- ❑ The site should include dedicated power circuits or power conditioners to supply reliable electrical power to the network devices.
- ❑ Copper cabling should not be exposed to sources of electrical noise, such as radio transmitters, broadband amplifiers, power lines, electric motors, or fluorescent fixtures.
- ❑ Switch ports are suitable for intra-building connections, or where non-exposed cabling is required.
- ❑ Do not install the device in a wiring or utility box that has inadequate airflow because it might overheat and fail.

Unpacking the Switch

To unpack the switch from its shipping box, perform the following procedure:

1. Remove the accessories and documents from the accessory partition. Refer to Figure 49.

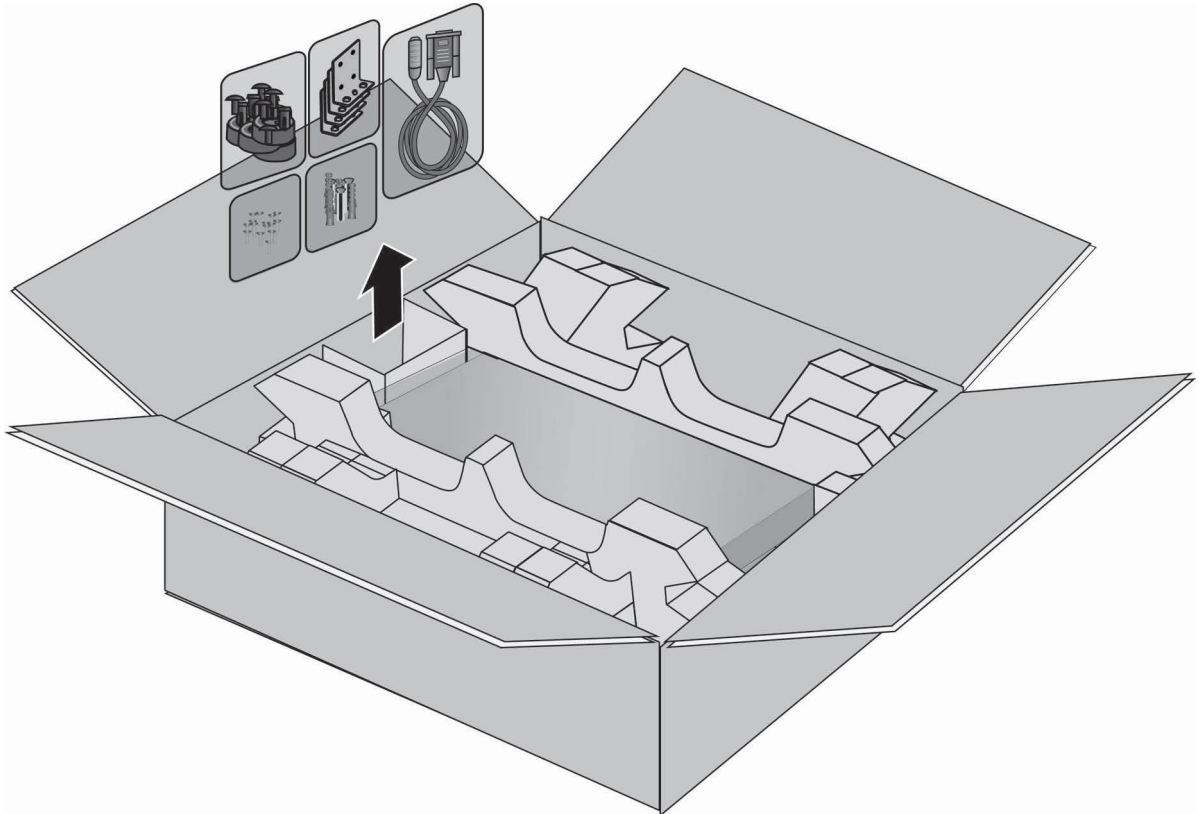

Figure 49. Removing Accessories

2. Remove the accessory partition. Refer to Figure 50 on page 118.

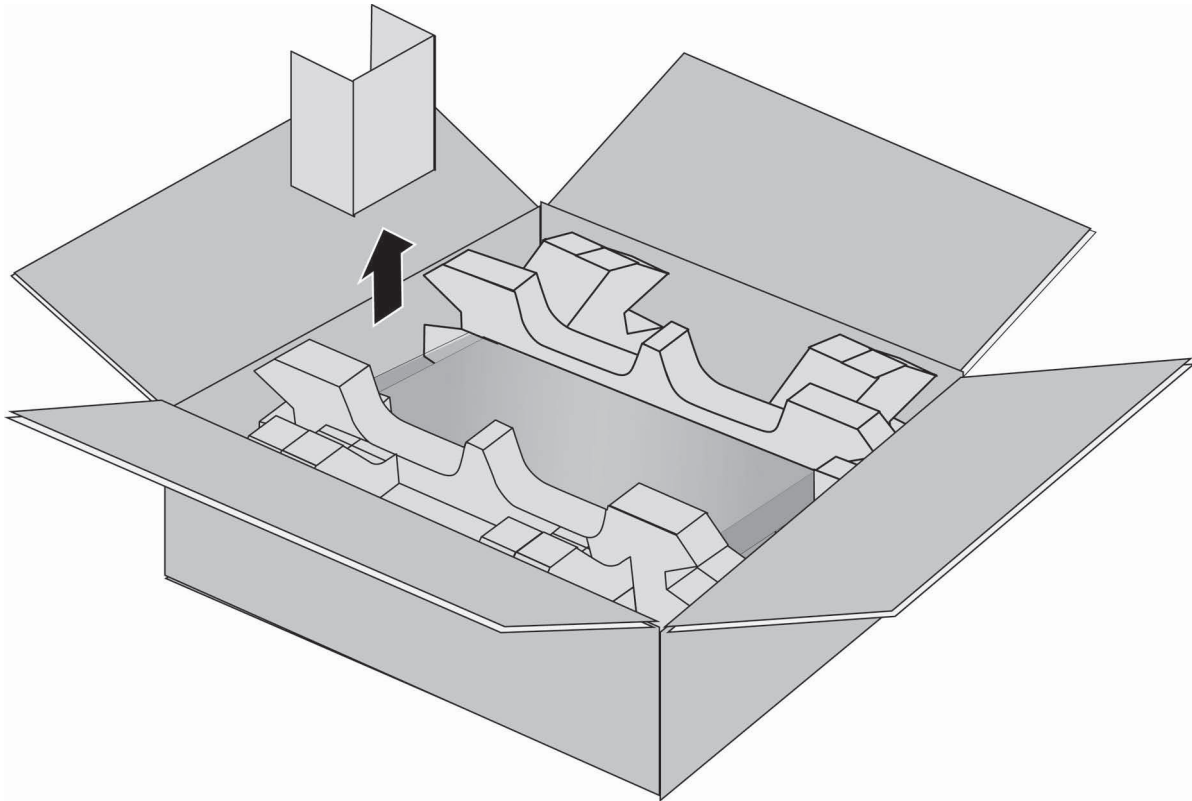

Figure 50. Removing the Shipping Partition

3. Lift the switch from the shipping box and place it on a level, secure table. Refer to Figure 51 on page 119.



Warning

The device is heavy. Always ask for assistance before moving or lifting it to avoid injure yourself or damage the equipment. *GE* E122

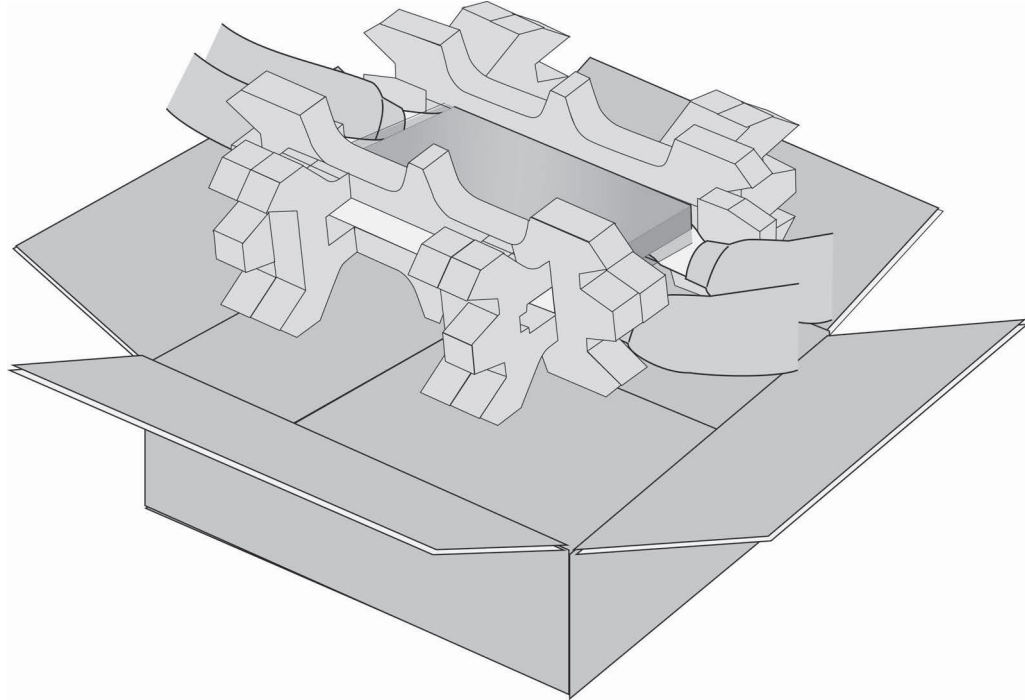

Figure 51. Lifting the Switch from the Shipping Box

4. Remove the switch from the shipping end-caps and protective bag. Refer to Figure 52.

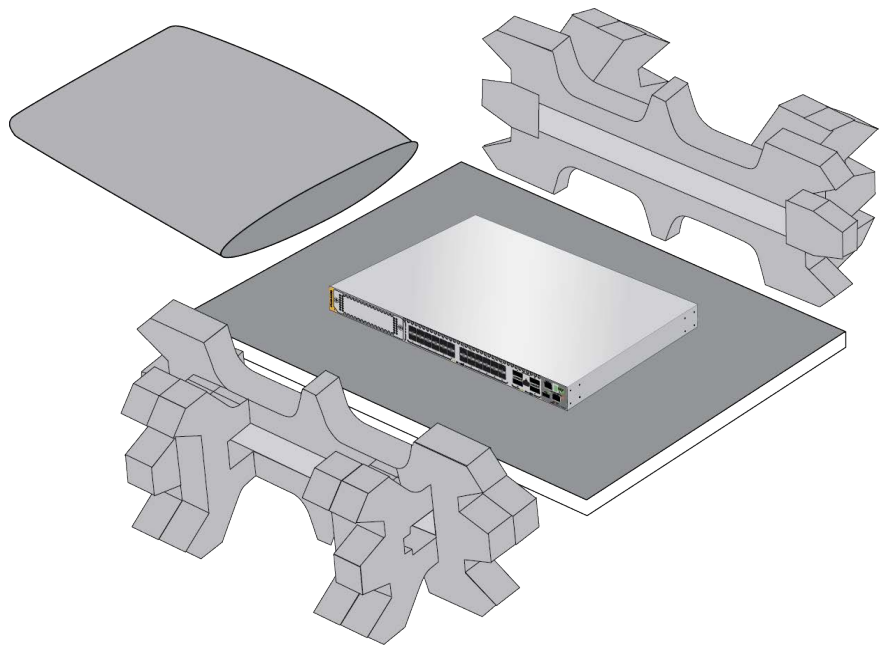

Figure 52. Removing the Switch from the Shipping End-caps and Protective Bag

5. Visually inspect the product for damage.
6. Visually inspect the front panel for the components shown in Figure 1 on page 20 and Figure 2 on page 21.
7. Verify that there are two pre-installed fan modules in FAN A and FAN B slots on the rear panel. Refer to Figure 3 on page 21 and “AT-FAN05 and AT-FAN05R Fan Modules” on page 52.

Note

Do not power on the switch if it is missing a fan module.

8. Go to “Verifying the Accessory Kit” on page 121.

Verifying the Accessory Kit

Table 38 lists the accessory items that are included with the switch.

Table 38. Accessory Kit





Item	Description
	<p>One 2 m (6.6 ft) local management cable with RJ-45 (8P8C) and DB-9 (D-sub 9-pin) connectors.</p>
	<p>Four standard mounting brackets</p> <hr/> <p>Note For the AT-x950-28XSQ and AT-x950-28XTQm Switches, these brackets are for both equipment rack and wall mounting.</p> <hr/> <p>Note For the AT-x950-52XSQ and AT-x950-52XTQm Switches, these brackets are only for wall mounting. For equipment rack mounting, use the rack mounting brackets shown in Table 39 on page 122.</p>
	<p>Sixteen M3x6mm screws for the standard mounting brackets</p>
	<p>Four anchors for concrete walls: Length: 29.6mm (1.2 in.) Diameter: 4mm (0.2 in.)</p>
	<p>Four screws for wood or concrete walls: Length: 32.6mm (1.3 in.) Diameter: 4mm (0.2 in.)</p>

Table 38. Accessory Kit

Item	Description
	Seven bumper feet

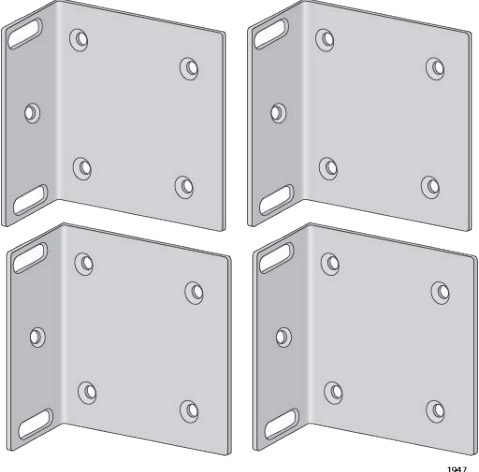
In addition to the accessory kit listed in Table 38 on page 121, the AT-x950-52XSQ and AT-x950-52XTQm Switches are shipped with the rack mounting brackets and screws as shown in Table 39.

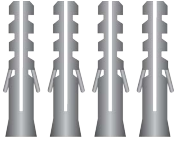
Table 39. Additional Accessory Kit for the AT-x950-52XSQ and AT-x950-52XTQm Switches

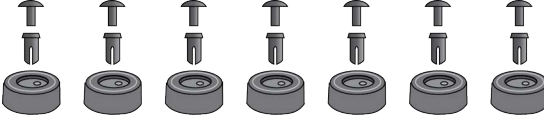
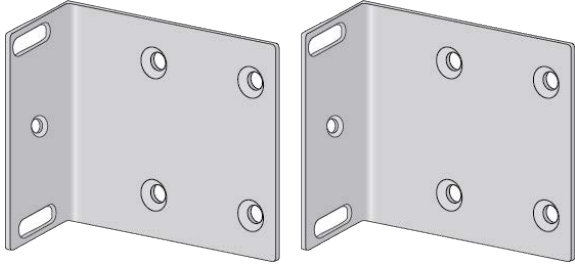
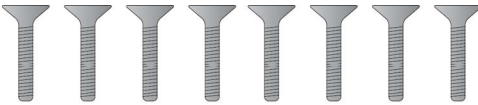
Item	Description
	Two rack mounting brackets for the AT-x950-52XSQ and AT-x950-52XTQm Switches
	Eight M4x7mm screws for the rack mounting brackets

Note

If any item is missing or damaged, contact your Allied Telesis sales representative for assistance.

After unpacking the switch and verifying the accessory kit, go to “Unpacking PWR600 AC and DC Power Supplies” on page 123.

Unpacking PWR600 AC and DC Power Supplies

To unpack AT-PWR600, AT-PWR600R, AT-PWR600-80, and AT-PWR600R-80 Power Supplies, perform the following procedure:

1. Remove the power cord and any documents from the accessory partition. Refer to Figure 53.

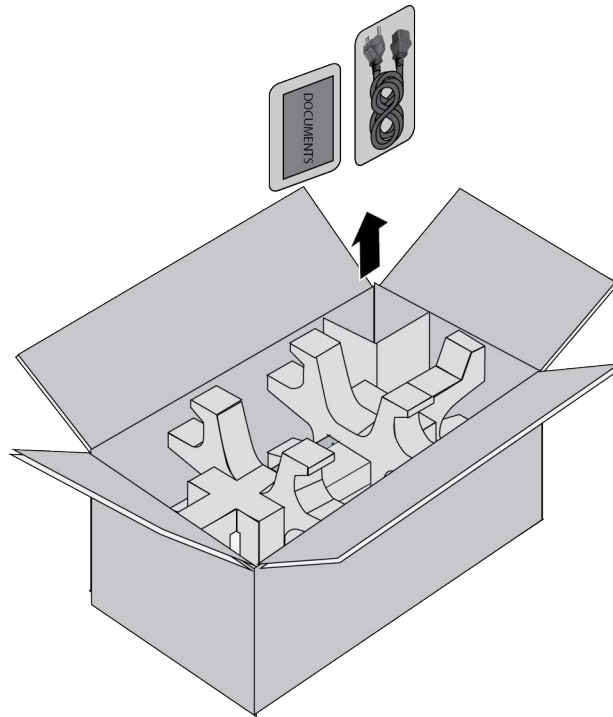

Figure 53. Removing the Power Cord and Documents from the Power Supply Shipping Box

Note

The AT-PWR600-80 and AT-PWR600R-80 DC Power Supplies do not come with power cords.

2. Remove the partition from the shipping box. Refer to Figure 54 on page 124.

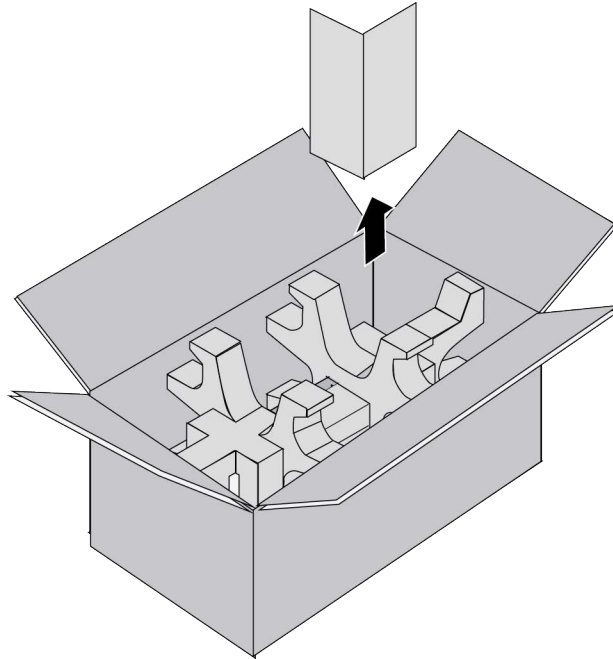

Figure 54. Removing the Partition from the Power Supply Shipping Box

3. Lift the power supply from the shipping box and place it on a level, secure table. Refer to Figure 55 on page 125.



Warning

The device is heavy. Always ask for assistance before moving or lifting it to avoid injure yourself or damage the equipment. *GE* E122

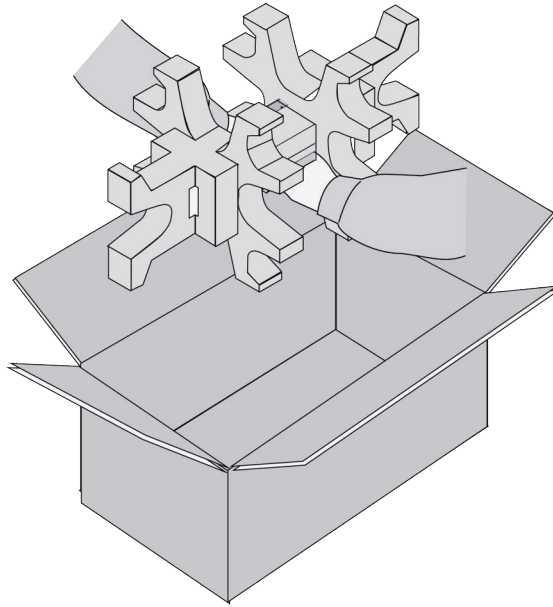

Figure 55. Removing the Power Supply from the Shipping Box

4. Remove the power supply from the shipping end-caps and protective shipping bag. Refer to Figure 56.

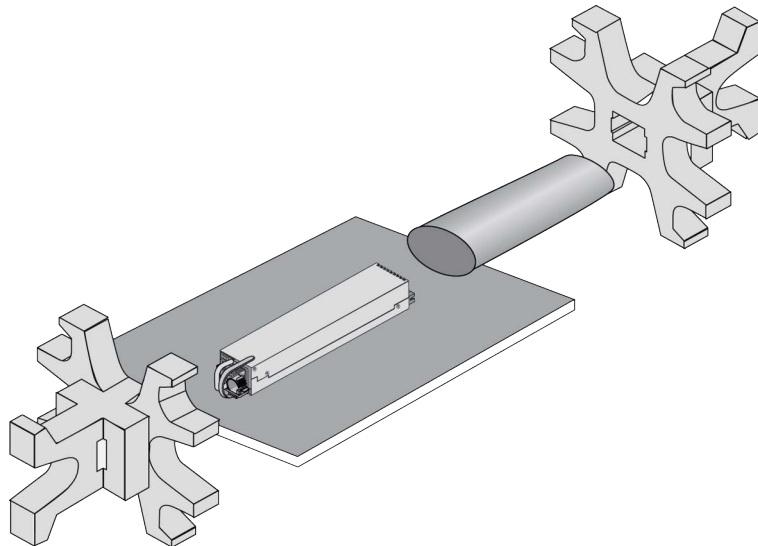

Figure 56. Removing the Power Supply from the Shipping End-caps and Protective Bag

5. Visually inspect the product for damage.
6. After unpacking the switch and power supplies, go to Chapter 5, “Installing Power Supplies and XEM2 Line Cards” on page 127.

Chapter 5

Installing Power Supplies and XEM2 Line Cards

This chapter has the following procedures:

- ❑ “Installing AT-PWR600 and AT-PWR600R AC Power Supplies” on page 128
- ❑ “Installing AT-PWR600-80 and AT-PWR600R-80 DC Power Supplies” on page 132
- ❑ “Installing XEM2 Ethernet Line Cards” on page 141

Installing AT-PWR600 and AT-PWR600R AC Power Supplies

This section contains the procedure for installing AT-PWR600 and AT-PWR600R AC Power Supplies in the switch. For background information, refer to “AT-PWR600 and AT-PWR600R AC and DC Power Supplies” on page 44. For the list of power supply components, refer to “Unpacking PWR600 AC and DC Power Supplies” on page 123.



Warning

The device is heavy. Use both hands to lift it. You might injure yourself or damage the device if you drop it.  E94



Caution

The device can be damaged by electrostatic discharge (ESD). Be sure to observe all standard electrostatic discharge (ESD) precautions, such as wearing an antistatic wrist strap, to guard against damaging the device.

After installing the power supplies and XEM2 Line Card, go to one of the following chapters:

- ❑ Chapter 6, “Installing the Switch on a Table” on page 145
- ❑ Chapter 7, “Installing the Switch in an Equipment Rack” on page 149
- ❑ Chapter 8, “Installing the Switch on a Wall” on page 157
- ❑ Chapter 9, “Installing the Switch in the RKMT-SL01 Sliding Rack” on page 173

To install the AT-PWR600 or AT-PWR600R AC Power Supply, perform the following procedure:

1. Choose a slot for the power supply. The two power supply slots are labeled PSU A and PSU B on the left side of the rear panel.

If you are installing only one power supply, you can install it in either slot. Allied Telesis recommends PSU A because that slot does not come with a blank power supply panel.
2. If there is already a power supply in PSU A, remove the blank panel from PSU B slot by pressing the release tab to the right and sliding the panel from the switch. Refer to Figure 57 on page 129.

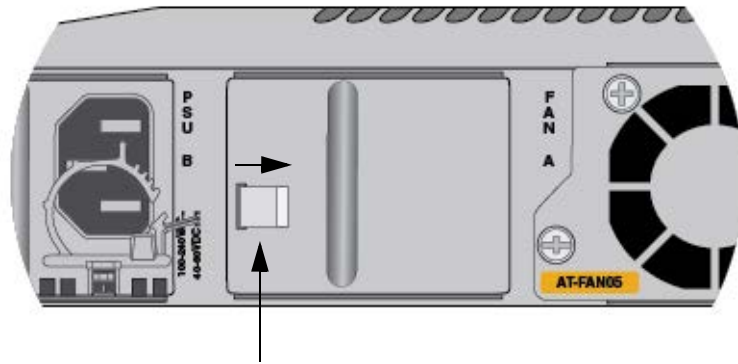

Release Tab

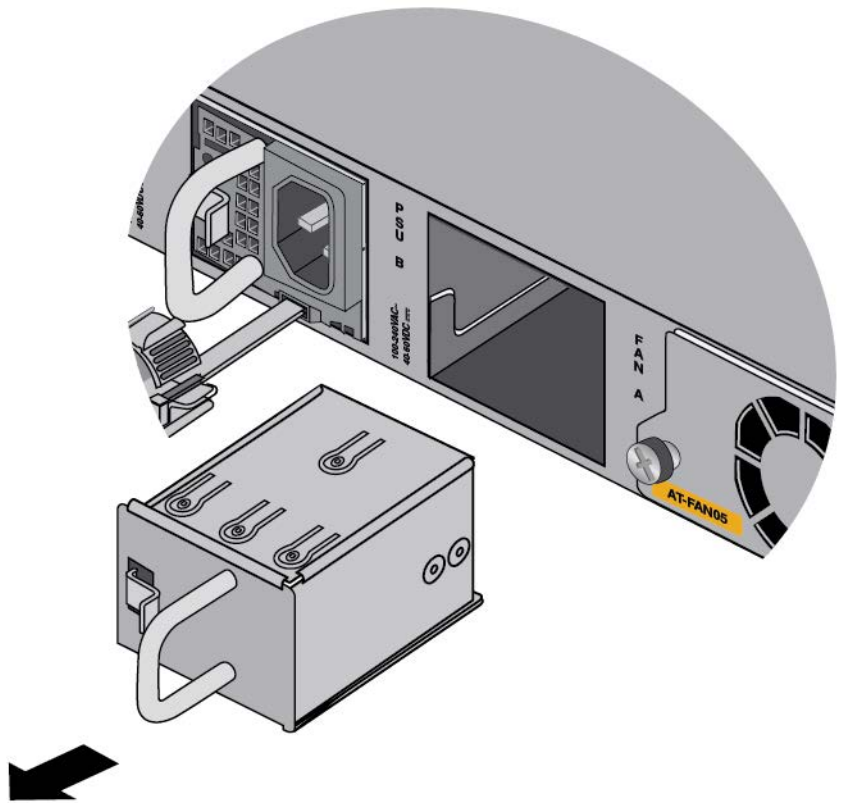

Figure 57. Removing the Blank Power Supply Panel from Slot PSU B

3. Carefully align the power supply in the slot and slide it into the slot. Figure 58 shows the module aligned for the PSU A slot.

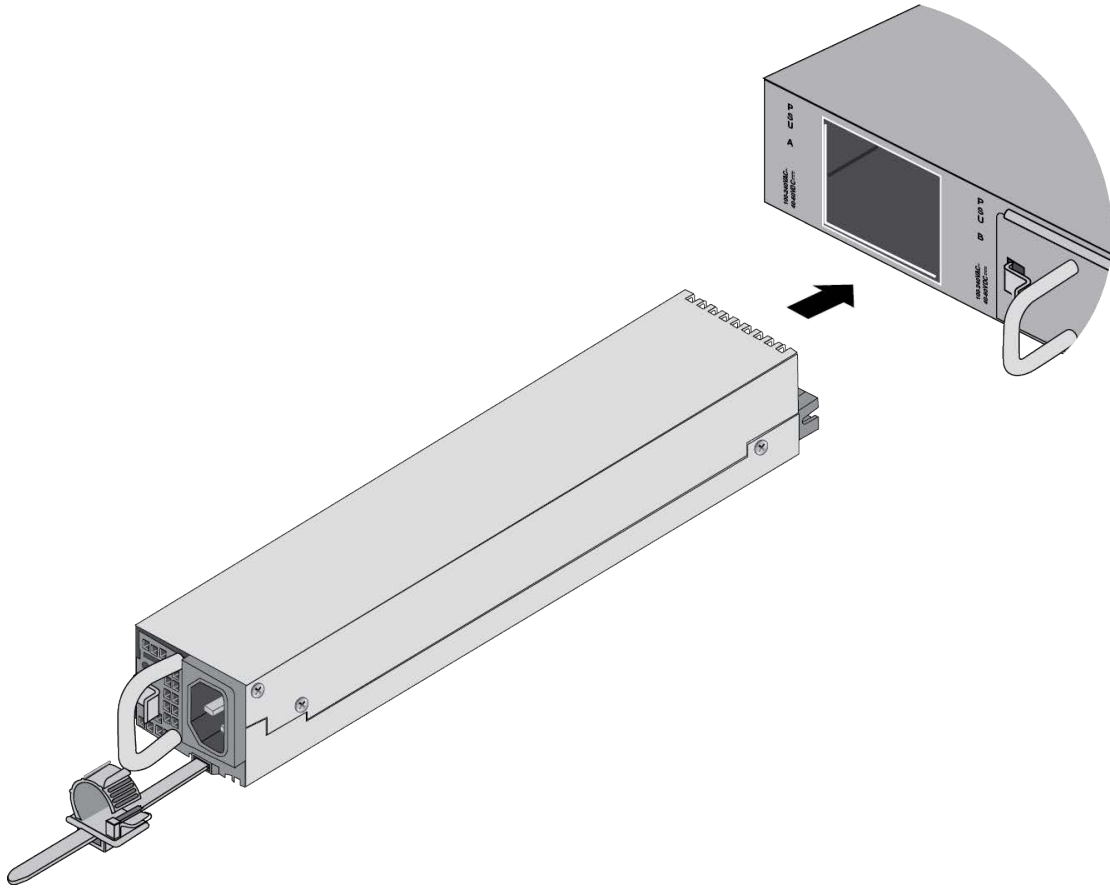

Figure 58. Sliding the AT-PWR600 or AT-PWR600R AC Power Supply into the Chassis

4. When the power supply makes contact with the connector inside the switch, gently press on its faceplate to seat it on the connector. Refer to Figure 59 on page 131.

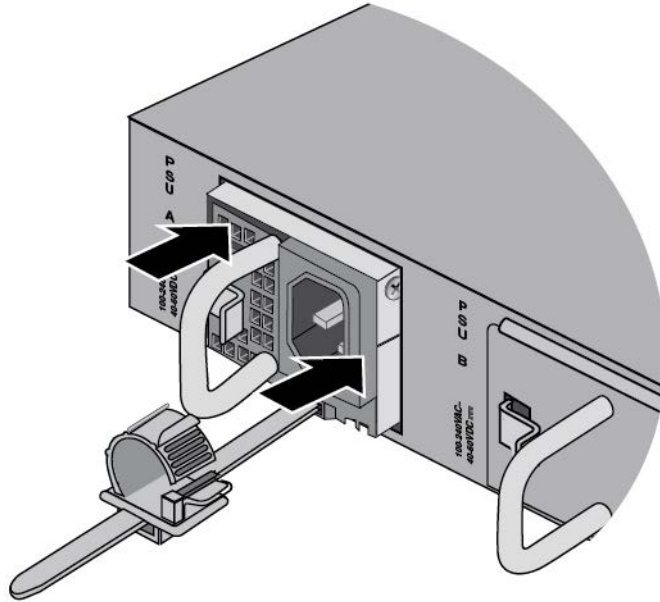

Figure 59. Seating the Power Supply on the Internal Connector

5. Visually inspect the power supply to be sure that its faceplate is flush against the rear panel of the chassis.
6. If you purchased two AC power supplies for the switch, repeat this procedure to install the second unit.
7. If you purchased a DC power supply as the second power supply, go to “Installing AT-PWR600-80 and AT-PWR600R-80 DC Power Supplies” on page 132.
8. To install an XEM2 Line Card, go to “Installing XEM2 Ethernet Line Cards” on page 141.

Installing AT-PWR600-80 and AT-PWR600R-80 DC Power Supplies

This section contains the procedures for installing and wiring AT-PWR600-80 and AT-PWR600R-80 DC Power Supplies in the switch. The procedure are:

- ❑ “Installing the Power Supply” on page 133
- ❑ “Connecting the Grounding Wire” on page 134
- ❑ “Connecting the DC Power Wires” on page 137

For background information, refer to “AT-PWR600 and AT-PWR600R AC and DC Power Supplies” on page 44. For instructions on unpacking the power supplies, refer to “Unpacking PWR600 AC and DC Power Supplies” on page 123.

After installing the power supplies, go to one of the following chapters or procedure:

- ❑ “Installing XEM2 Ethernet Line Cards” on page 141
- ❑ Chapter 6, “Installing the Switch on a Table” on page 145
- ❑ Chapter 7, “Installing the Switch in an Equipment Rack” on page 149
- ❑ Chapter 8, “Installing the Switch on a Wall” on page 157
- ❑ Chapter 9, “Installing the Switch in the RKMT-SL01 Sliding Rack” on page 173



Warning

The device is heavy. Use both hands to lift it. You might injure yourself or damage the device if you drop it. *E94*



Caution

The electronic components on the device can be damaged by electrostatic discharge (ESD). Follow the procedure in “Protecting Against Electrostatic Discharge (ESD)” to guard against ESD damage when unpacking or installing the device. *E106*

Installing the Power Supply

To install the PWR600-80 or AT-PWR600R-80 DC Power Supply in the switch, perform the following procedure:

1. Choose a slot for the power supply. The two power supply slots are labeled PSU A and PSU B on the left side of the rear panel.

If you are installing only one power supply, you can install it in either slot. Allied Telesis recommends PSU A because that slot does not come with a blank power supply panel.

2. If there is already a power supply in PSU A, remove the blank panel from PSU B slot by pressing the release tab to the right and sliding the panel from the switch. Refer to Figure 57 on page 129.
3. Carefully align the power supply in the slot and slide it into the slot. Figure 60 shows the module aligned for the PSU A slot.

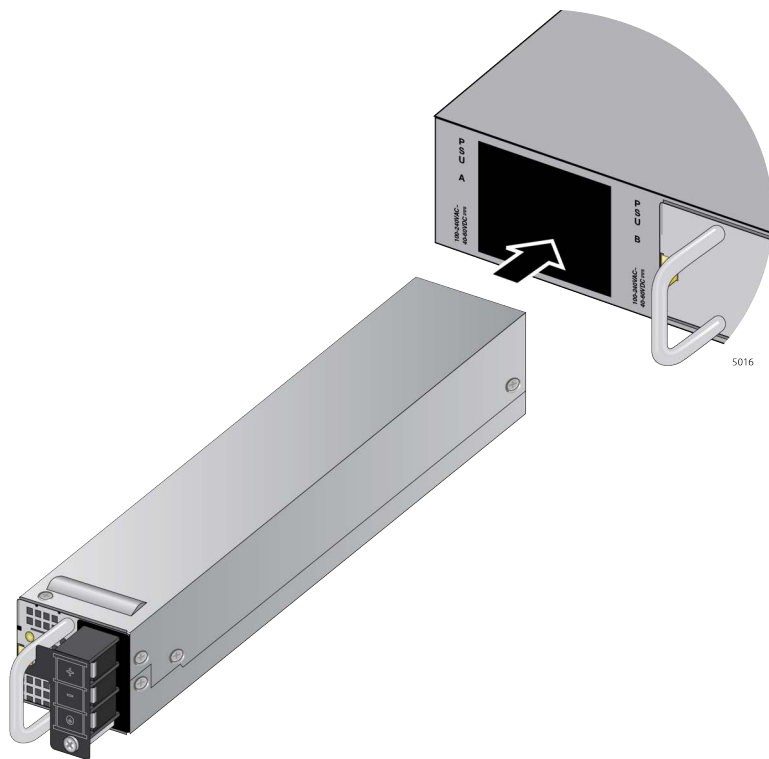

Figure 60. Sliding the PWR600-80 DC Power Supply into the Chassis

4. When the power supply makes contact with the connector inside the switch, gently press on its faceplate to seat it on the connector.
5. Visually inspect the power supply to be sure that its faceplate is flush against the rear panel of the chassis.
6. If you purchased two DC power supplies for the switch, repeat this procedure to install the second unit.

7. After installing the PWR600-80 DC Power Supplies, go “Connecting the Grounding Wire” next.

Connecting the Grounding Wire

Here are the guidelines for the grounding wire:

- The wire should be minimum #16 AWG solid wire.
- The wire length should be as short as possible.
- Continuity from the grounding screw to the earth ground must be less than 0.05 ohms.
- If a terminal is used, it should be double crimped.



Warning

The equipment must be earthed. The ground screw on the unit must be connected to a properly earthed bonding point. ⚡ E120



Warning

When installing this equipment, always ensure that the frame ground connection is installed first and disconnected last. ⚡ E11

The material and tools you need for connecting the ground wire:

- Minimum #16 AWG solid wire
- Wire insulation stripper
- Phillips-head screwdriver

To connect the grounding wire with bare wire, perform the following procedure:

1. Strip 2.54cm (1.0 in.) of insulation from the end of the solid grounding wire with a wire insulator stripper. Refer to Figure 61.

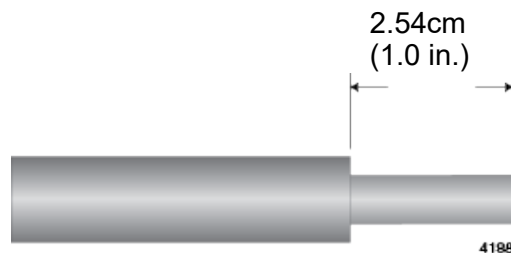



Figure 61. Stripping the Grounding Wire



Warning

Do not strip more than the recommended amount of wire. Stripping more than the recommended amount can create a safety hazard by leaving exposed wire on the terminal block after installation.  E10

- Loosen the screw for the connector panel several turns with a Phillips-head screwdriver. Refer to Figure 62.

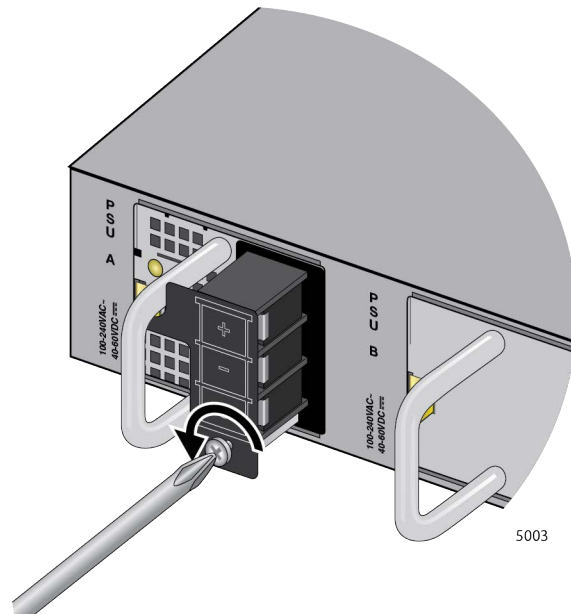

Figure 62. Loosening the Screw for the Panel

- Press the panel to the right to expose the connectors as shown in Figure 63.

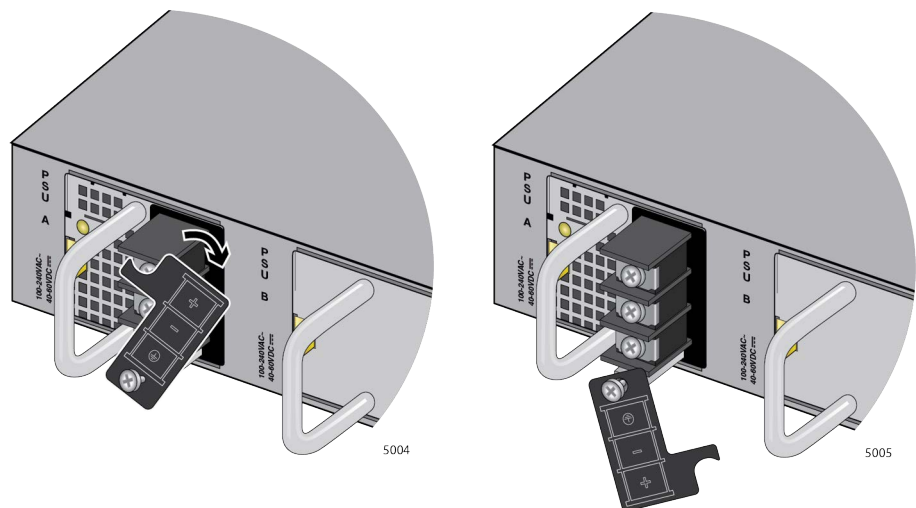

Figure 63. Accessing the Connectors

4. Loosen the ground screw with a Phillips-head screwdriver. Refer to Figure 64.

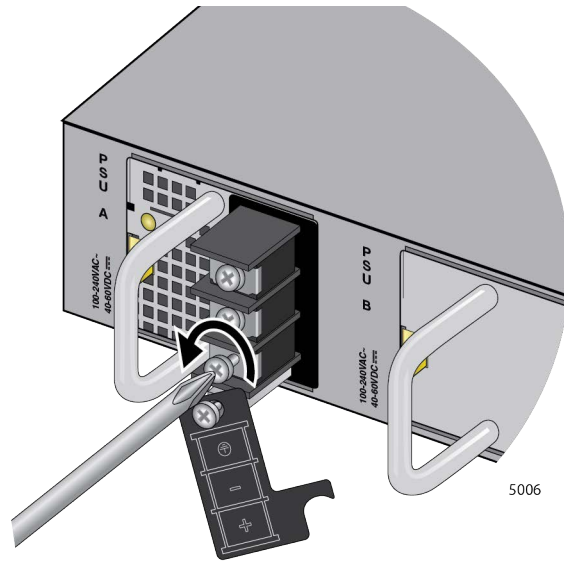

Figure 64. Loosening the Ground Screw

5. Wind the grounding wire clockwise around the base of the grounding screw. Refer to Figure 65.

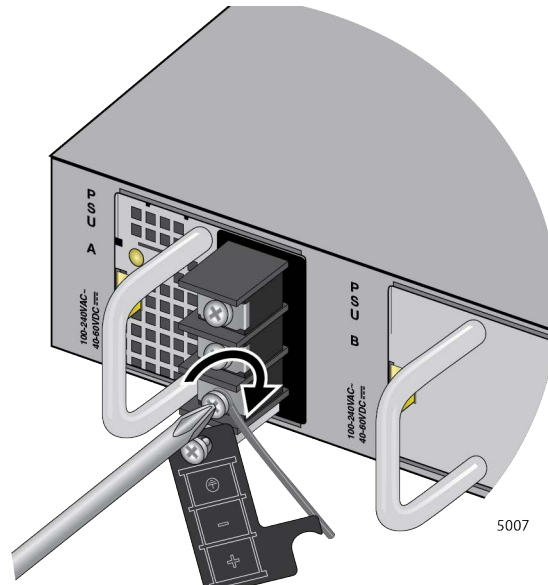

Figure 65. Wrapping the Grounding Wire and Tightening the Screw

6. Tighten the ground screw.
7. Connect the other end of the ground wire to a ground point at the installation site.
8. Go to “Connecting the DC Power Wires” on page 137.

Connecting the DC Power Wires

Here are the materials and tools for connecting the DC power cables:

- ❑ 18 AWG stranded wires. Do not use wire heavier than 16 AWG solid wire.
- ❑ Wire insulation stripper
- ❑ Phillips-head screwdriver

To connect the DC power cables, perform the following procedure:

1. Strip 6.5mm (0.25 in.) of insulation from the end of the stranded power wires with a wire insulator stripper. Refer to Figure 63.

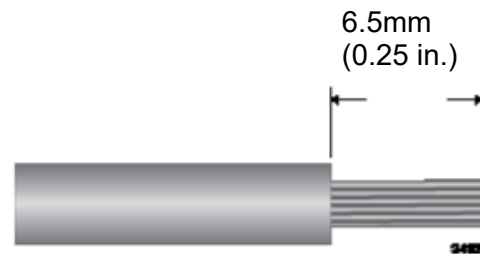

Figure 66. Stripping the Power Wire



Warning

Do not strip more than the recommended amount of wire. Stripping more than the recommended amount can create a safety hazard by leaving exposed wire on the terminal block after installation. *GE* E10

2. Tightly wrap the wire strands with your finger tips.



Figure 67. Wrapping the Wire Strands

This step is to prevent loose strands from touching other wires and causing an electrical short.

Note

Allied Telesis recommends tinning the wires with solder for added protection against loose strands. This guide does not provide instructions on how to tin wires.

3. Loosen the middle screw for the negative (-) with a Phillips-head screwdriver. Refer to Figure 68.

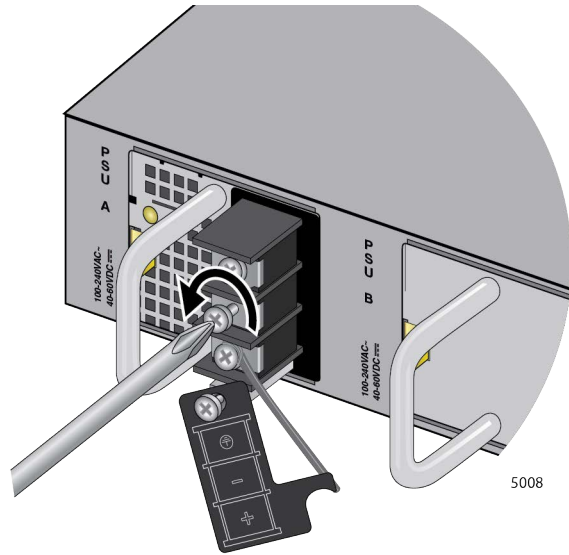

Figure 68. Loosening the Screw for the Negative (-)

4. Wind the power wire and tighten the screw. Refer to Figure 69.

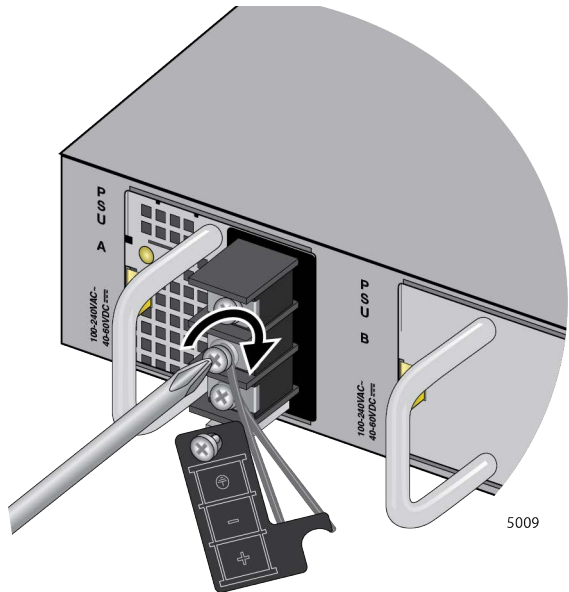

Figure 69. Tightening the Screw for the Negative (-)

- Loosen the top screw for the positive (+) with a Phillips-head screwdriver. Refer to Figure 70.

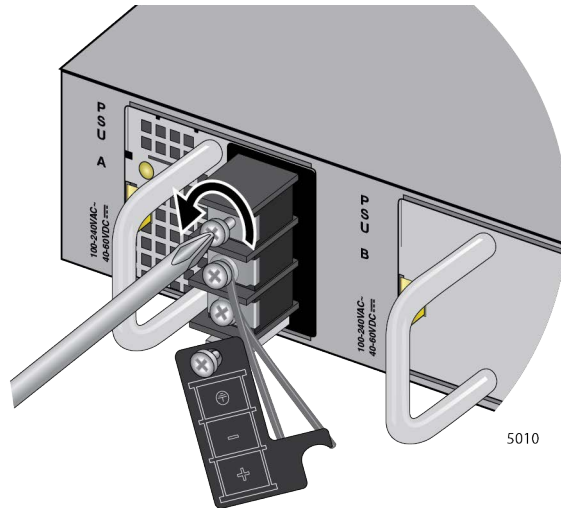

Figure 70. Loosening the Screw for the Negative (+)

- Wind the power wire and tighten the screw. Refer to Figure 71.

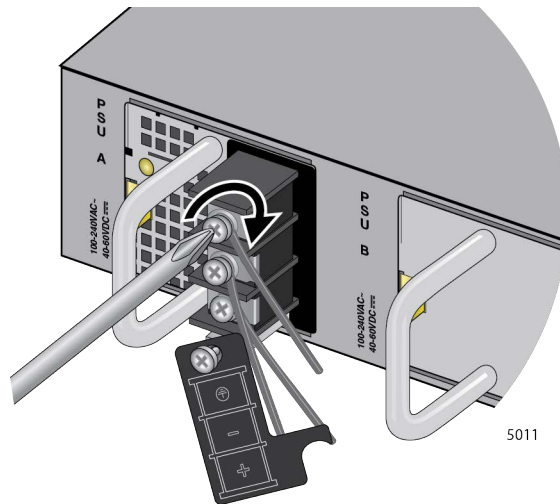

Figure 71. Tightening the Screw for the Negative (+)

- After attaching the wires to the screws, verify that there are no exposed wires or loose wire strands.



Warning

Check to see if there are any exposed copper strands coming from the installed wires. When this installation is done correctly there should be no exposed copper wire strands extending from the terminal block. Any exposed wiring can conduct harmful levels of electricity to persons touching the wires. ⚡ E12

8. Place the cover panel back to cover the connectors. Refer to Figure 72.

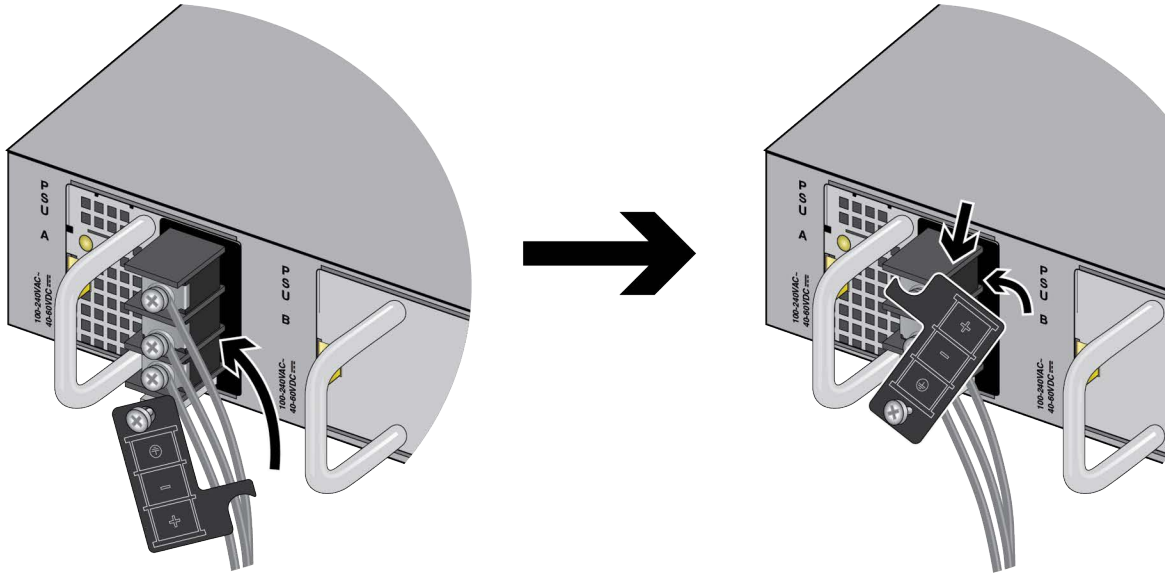

Figure 72. Placing the Cover Panel

9. Tighten the screw for the cover panel. Refer to Figure 73.

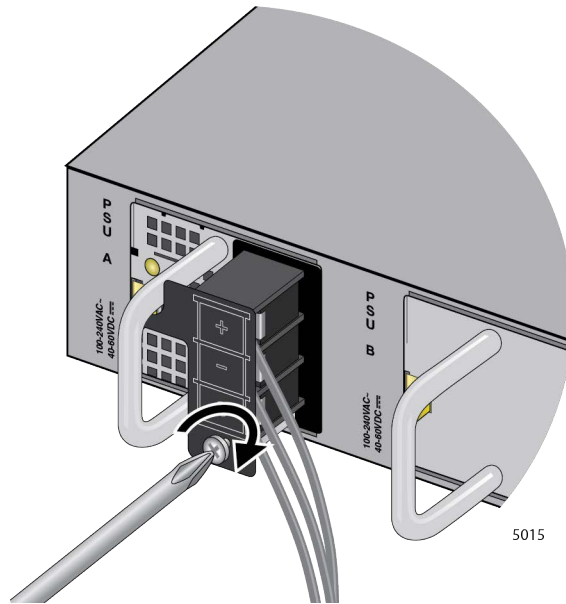

Figure 73. Tightening the Screw for the Cover Panel

Installing XEM2 Ethernet Line Cards

This section contains the procedure for installing XEM2 Line Cards in the expansion slot in the front panels of the AT-x950-28XSQ and AT-x950-28XTQm Switches. For background information, refer to Chapter 2, “XEM2 Ethernet Line Cards” on page 61. The illustrations show the AT-XEM2-12XT Line Card. The procedure is the same for all line cards.

Note

The AT-x950-52XSQ and xAT-950-52XTQm Switches do not support XEM2 Line Cards.



Caution

The device can be damaged by static electricity. Be sure to follow proper anti-static precautions when installing the device. Allied Telesis recommends using a properly grounded wrist strap or other personal anti-static device and an anti-static mat.

To install an XEM2 Line Card, perform the following procedure:

1. Using a #2 Phillips-head screwdriver, loosen the two captive screws on the blank expansion slot panel and remove it from the switch. Refer to Figure 74.

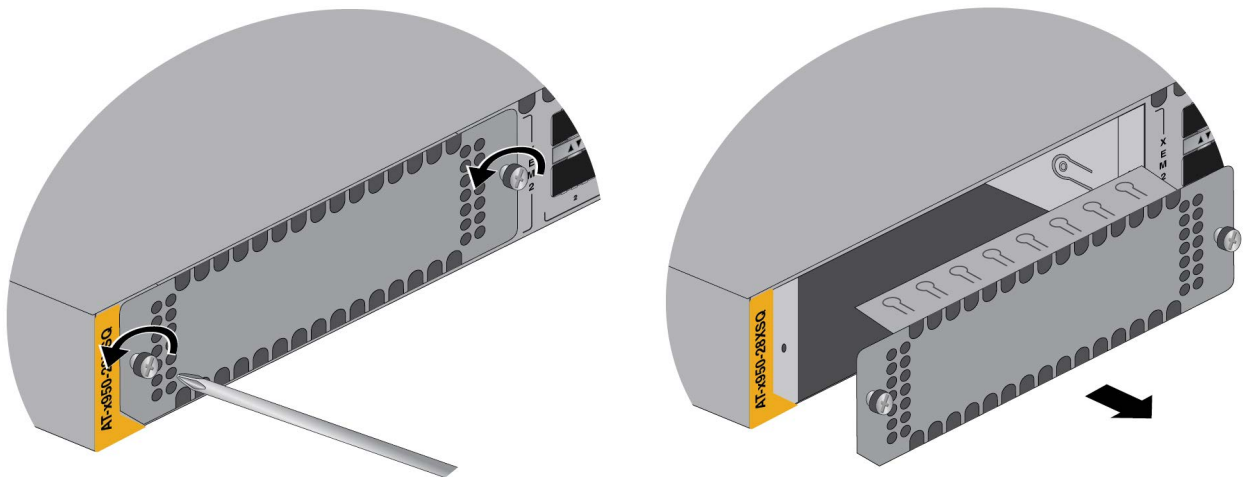

Figure 74. Removing the Blank Line Card Cover

- Carefully remove the XEM2 Line Card from its shipping container and anti-static bag. Refer to Figure 75.



Figure 75. Removing the XEM2 Line Card from the Anti-static Bag

- Position the line card with the notch on the faceplate in the bottom left corner, as shown in Figure 76, and carefully slide it into the slot.

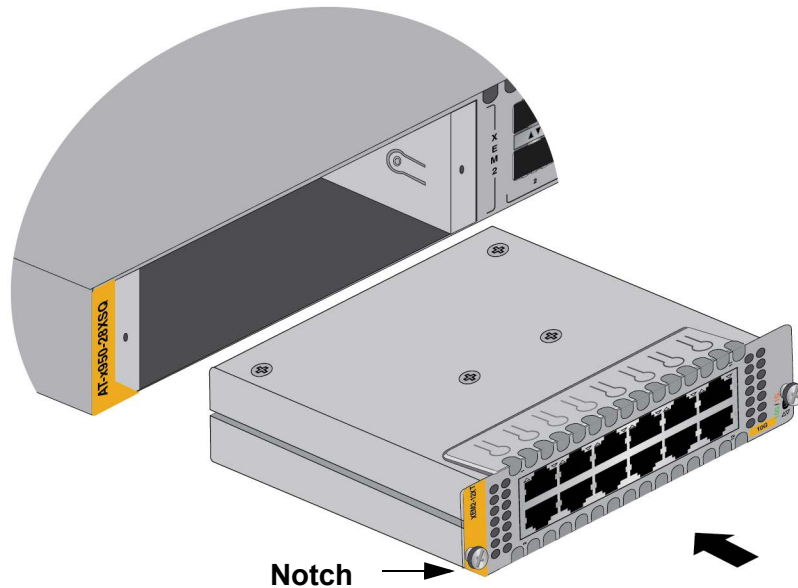

Figure 76. Sliding the XEM2 Line Card into the Slot



Caution

Do not use excessive force when seating the module, because this may damage the system or the module. If the module resists seating, remove it from the system, realign it, and try again. *E47*

4. When the line card makes contact with the internal connector in the switch, gently press on the sides of its faceplate to seat it on the connector. Refer to Figure 77.

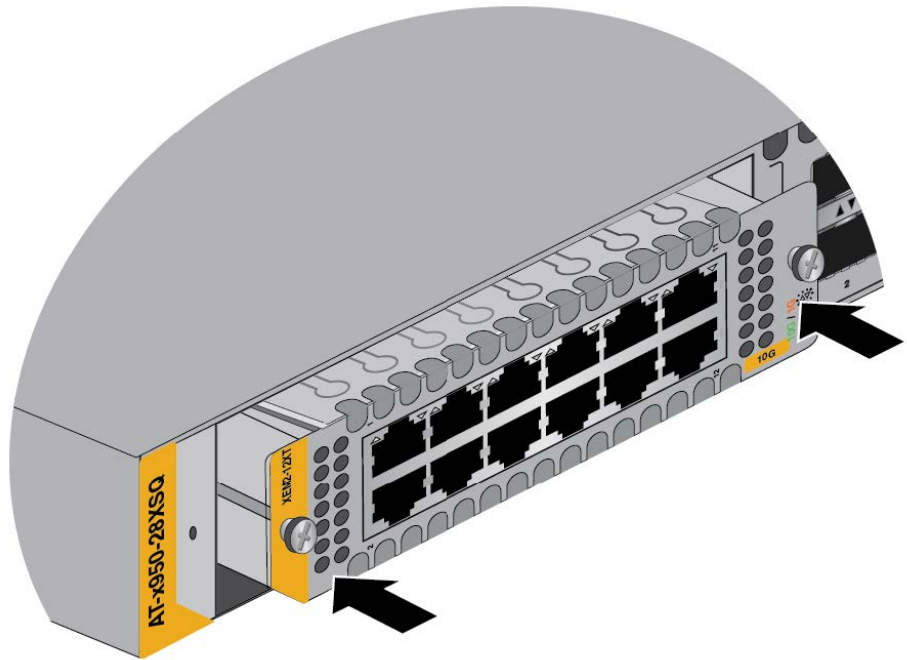

Figure 77. Seating the XEM2 Line Card in the Expansion Slot

5. Visually inspect the line card to verify that its faceplate is flush against the front panel of the switch.
6. Tighten the two captive screws on the card to secure it in the switch. Refer to Figure 78 on page 144.

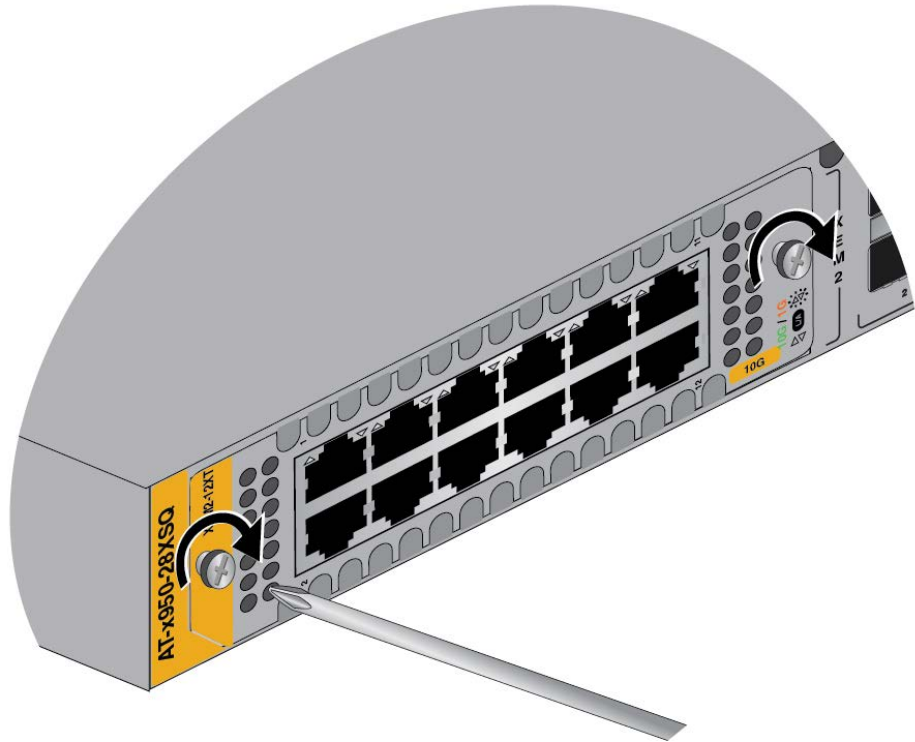

Figure 78. Tightening the Two Captive Screws on the XEM2 Line Card

7. After installing the power supplies and XEM2 Line Card, go to one of the following chapters:
 - Chapter 6, “Installing the Switch on a Table” on page 145
 - Chapter 7, “Installing the Switch in an Equipment Rack” on page 149
 - Chapter 8, “Installing the Switch on a Wall” on page 157
 - Chapter 9, “Installing the Switch in the RKMT-SL01 Sliding Rack” on page 173

Chapter 6

Installing the Switch on a Table

This chapter contains the instructions for installing the switch on a table or desktop.



Warning

Switches should not be stacked on a table or desktop. They could present a physical safety hazard if you need to move or replace switches. *E91*



Warning

The device is heavy. Always ask for assistance when moving or lifting it to avoid injuring yourself or damaging the equipment. *E122*

The switch comes with seven bumper feet in the accessory kit. The feet, which are reusable, are used when installing the switch on a table. If they are already assembled, disassemble them by removing the rivets and rivet housings from the bumper feet. Refer to Figure 79.

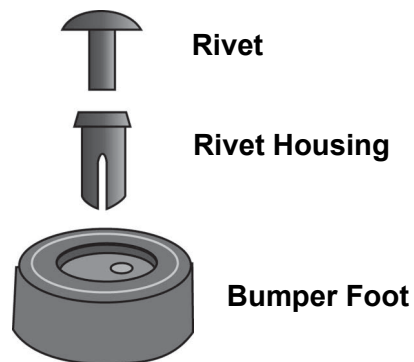

Figure 79. Parts of the Bumper Feet

The holes in the base of the switch for the bumper feet are shown in Figure 80 on page 146.

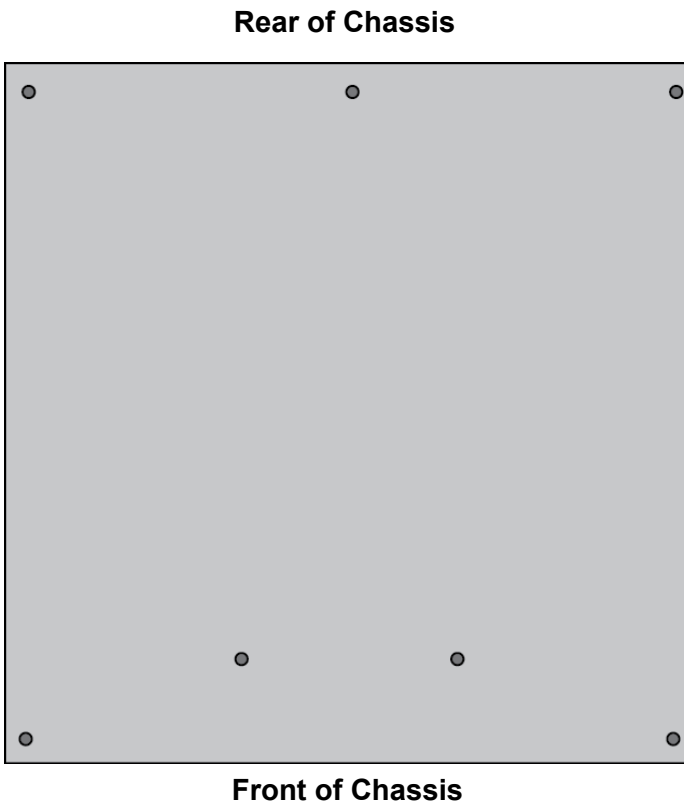

Figure 80. Holes for Bumper Feet

Note

The following procedure assumes that you have already reviewed the information and performed the procedures in Chapter 4, “Beginning the Installation” on page 109.

To install the switch on a table, perform the following procedure:

1. Place the switch upside down on a table.
2. Inset a rivet housing into a bumper foot. Refer to Figure 81.

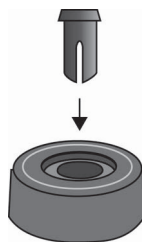

Figure 81. Inserting the Rivet Housing into the Bumper Foot

- Place the bumper foot onto one of the holes in the base of the switch. Refer to Figure 82.

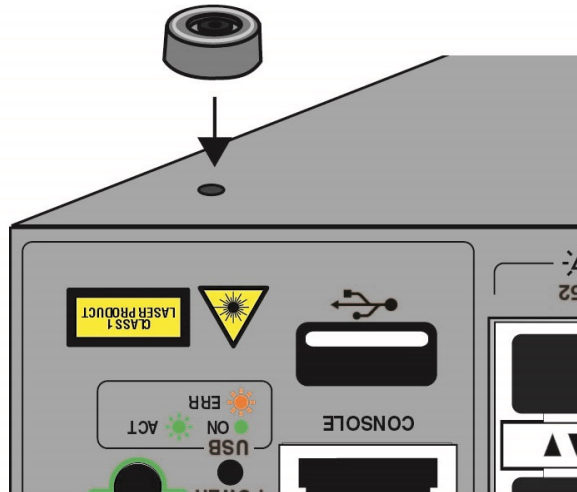

Figure 82. Placing the Bumper Foot on a Base Corner Hole

- Insert the rivet to secure the bumper foot to the base. Refer to Figure 83.

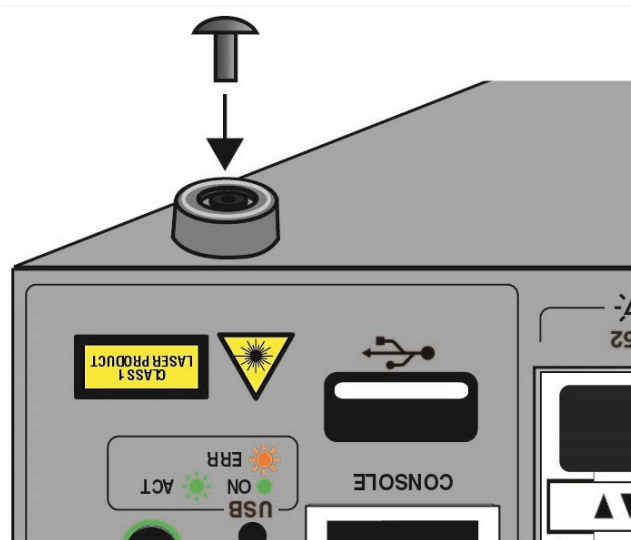

Figure 83. Inserting the Rivet into the Bumper Foot

- Repeat steps 2 to 4 to install the remaining bumper feet.
- Turn the switch over and place it on a flat, secure desk or table, leaving ample space around it for ventilation.

7. Do one of the following:
 - ❑ To install power supplies, go to “Installing AT-PWR600 and AT-PWR600R AC Power Supplies” on page 128 or “Installing AT-PWR600-80 and AT-PWR600R-80 DC Power Supplies” on page 132.
 - ❑ To install an optional XEM2 Ethernet Line Card, go to “Installing XEM2 Ethernet Line Cards” on page 141.
 - ❑ After installing the switches of the stack, go to Chapter 10, “Configuring the Master Switch” on page 197.

Chapter 7

Installing the Switch in an Equipment Rack

This chapter contains instructions for installing the switch in a standard 19-inch equipment rack. The procedures in this chapter are listed here:

- “Beginning the Installation” on page 150
- “Removing the Bumper Feet” on page 152
- “Installing the Switch” on page 153

Beginning the Installation

This chapter contains the procedure for installing the switch in a standard 19-inch equipment rack, with the brackets included with the unit.

Required Items

The following items are required to install the switch in an equipment rack:

- Two equipment rack brackets (included with the switch)
- Eight M4x6mm bracket screws (included with the switch)
- Cross-head screwdriver (not provided)
- Four standard equipment rack screws (not provided)

Switch Orientations in the Equipment Rack

Figure 84 identifies the holes for the standard brackets on the x950-28XSQ and x950-28XTQm switches.

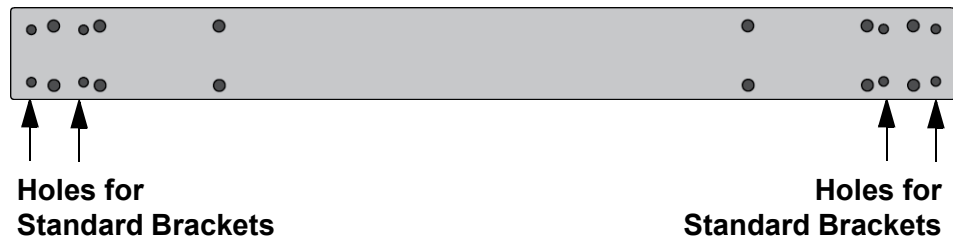

Figure 84. Holes for the Equipment Rack Brackets on the x950-28XSQ and x950-28XTQm Switches

Figure 85 identifies the holes for the equipment rack brackets on the x950-52XSQ and x950-52XTQm switches.



Figure 85. Holes for the Equipment Rack Brackets on the x950-52XSQ and x950-52XTQm Switches

You can install the switch with its front panel flush with or extending in front of the equipment rack. The illustrations in Figure 86 show the possible switch orientations in the equipment rack.



Figure 86. Switch Orientations in an Equipment Rack

Removing the Bumper Feet

The bumper feet included with the switch should not be used when installing the device in an equipment rack. If they are already installed, perform the following procedure to remove them:

1. Place the switch upside down on a level, secure surface.
2. Use a small flat-head screwdriver to gently pry the feet from the bottom of the switch. Refer to Figure 87.

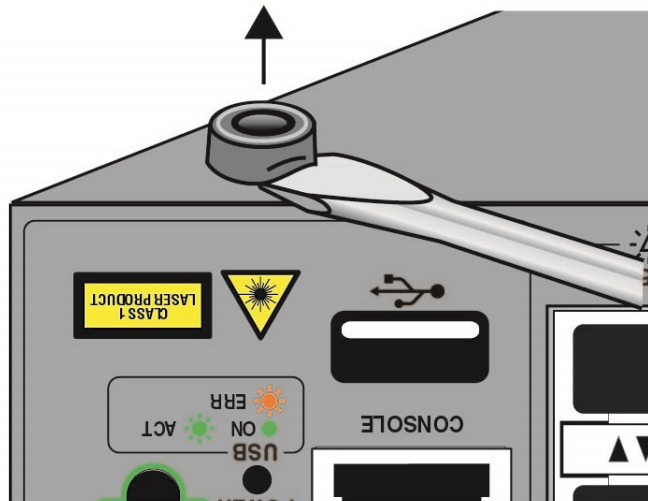

Figure 87. Removing the Bumper Feet

3. Turn the switch back over.
4. Go to "Installing the Switch" on page 153.

Installing the Switch

Please review the information and perform the procedures in Chapter 4, “Beginning the Installation” on page 109 before installing the switch.



Caution

The chassis may be heavy and awkward to lift. Allied Telesis recommends that you get assistance when mounting the chassis in an equipment rack. *See* E28

Note

The switch can be installed in an equipment rack with the optional RKMT-SL01 Sliding Rack Mount Kit. For instructions, refer to the *RKMT-SL01 Sliding Rack Mount Kit Installation Guide*.

Note

The switch comes with four brackets. Installing the device in an equipment rack requires only two brackets. All four brackets are used to install the switch on a wall.

To install the switch in a 19-inch equipment rack, perform the following procedure:

1. Place the unit on a level, secure surface.
2. If you have not chosen an orientation for the switch in the equipment rack, review “Switch Orientations in the Equipment Rack” on page 150.
3. Attach two brackets to the sides of the switch in the selected positions, showed in n Figure 88 on page 154. The illustration in Figure 88 on page 154 shows the installation of the brackets so that the front panel is even with the front of the equipment rack.
 - ❑ For the x950-28XSQ and x950-28XTQm switches, use two of the four standard brackets with eight of the M3-6mm screws listed in Table 38 on page 121.
 - ❑ For the x950-52XSQ and x950-52XTQm switches, use the two rack mounting brackets and the eight M4x7mm screws listed in Table 39 on page 122.



Figure 88. Attaching the Equipment Rack Brackets

4. Have another person hold the switch in the equipment rack while you secure it using standard equipment rack screws (not provided). Refer to Figure 89.

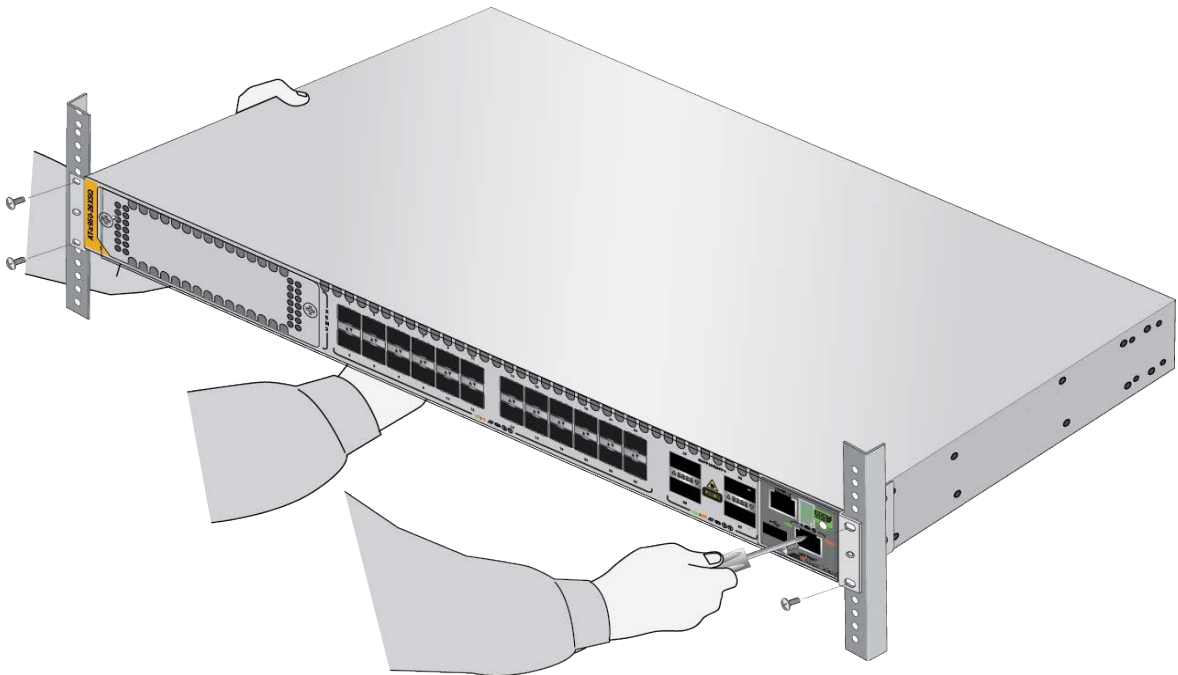

Figure 89. Installing the Switch in an Equipment Rack

5. Do one of the following:
 - ❑ To install power supplies, go to “Installing AT-PWR600 and AT-PWR600R AC Power Supplies” on page 128.
 - ❑ To install an optional XEM2 Ethernet Line Card, go to “Installing XEM2 Ethernet Line Cards” on page 141.
 - ❑ After installing both switches of the stack, go to Chapter 10, “Configuring the Master Switch” on page 197.

Chapter 8

Installing the Switch on a Wall

The procedures in this chapter are listed here:

- “Switch Orientations on a Wall” on page 158
- “Recommended Minimum Wall Area Dimensions” on page 159
- “Plywood Base for a Wall with Wooden Studs” on page 161
- “Installation Guidelines” on page 163
- “Installing the Plywood Base” on page 165
- “Installing the Switch on the Plywood Base” on page 166
- “Installing the Switch on a Concrete Wall” on page 169

Switch Orientations on a Wall

You can install the switch on a wall with the front panel on the left or right, as shown in Figure 90. Do not install it with the front panel on the top or bottom.

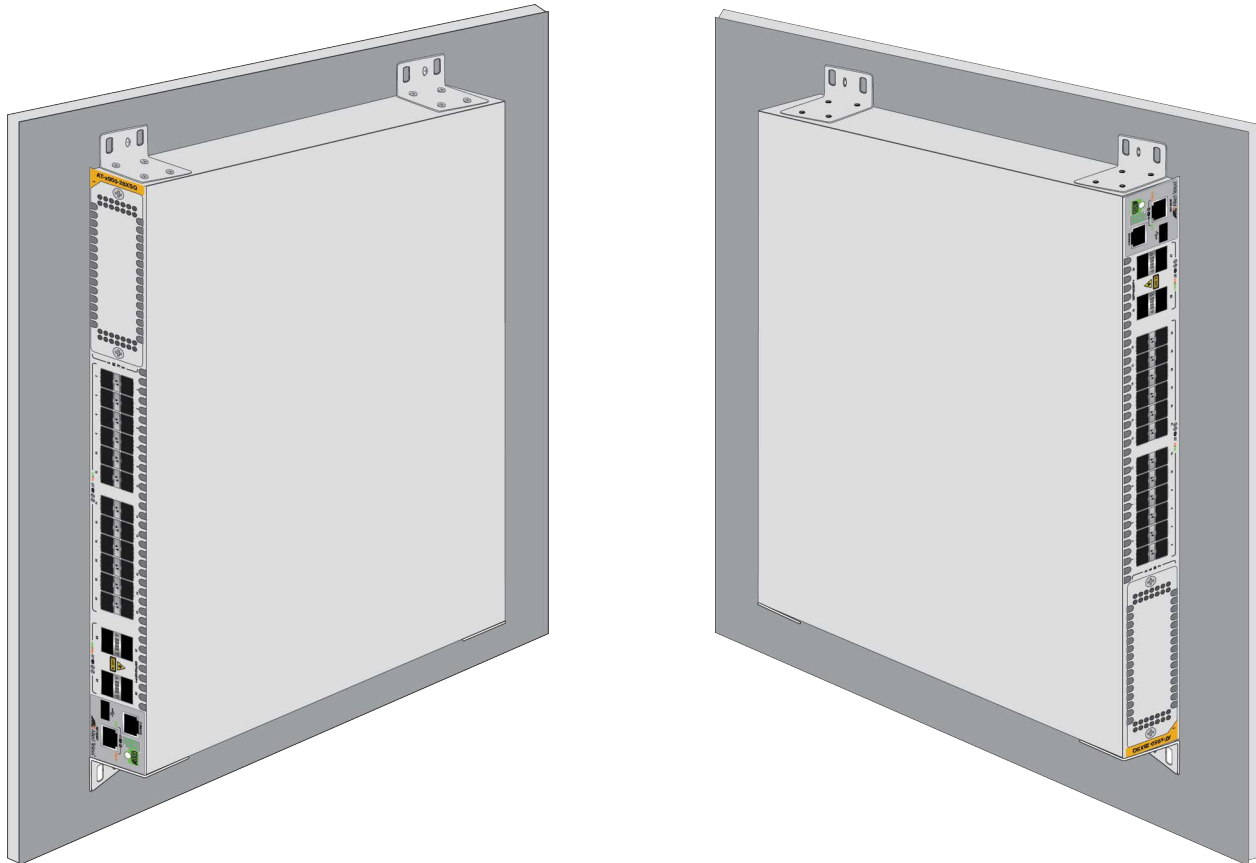

Figure 90. Positions of the Switch on the Wall

Recommended Minimum Wall Area Dimensions

The recommended minimum dimensions for the reserved wall area for the switch are listed here:

- Width: 77.4 centimeters (31 inches)
- Height: 58.4 centimeters (23 inches)

Figure 91 and Figure 92 on page 160 illustrate the recommended positions of the switch in the reserved area when the front panel is on the left and right, respectively. Be sure to leave sufficient space on the rear panel so that you can replace power supplies or fan modules, if necessary.

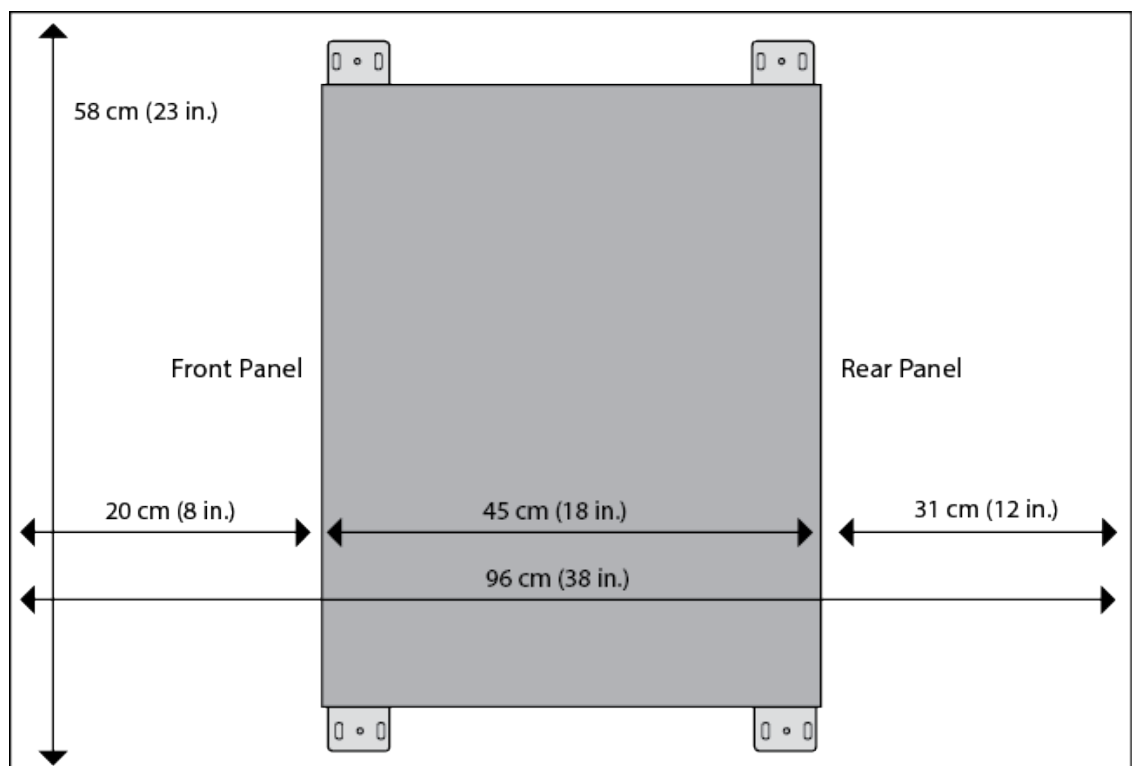

Figure 91. Minimum Wall Area Dimensions with the Front Panel on the Left

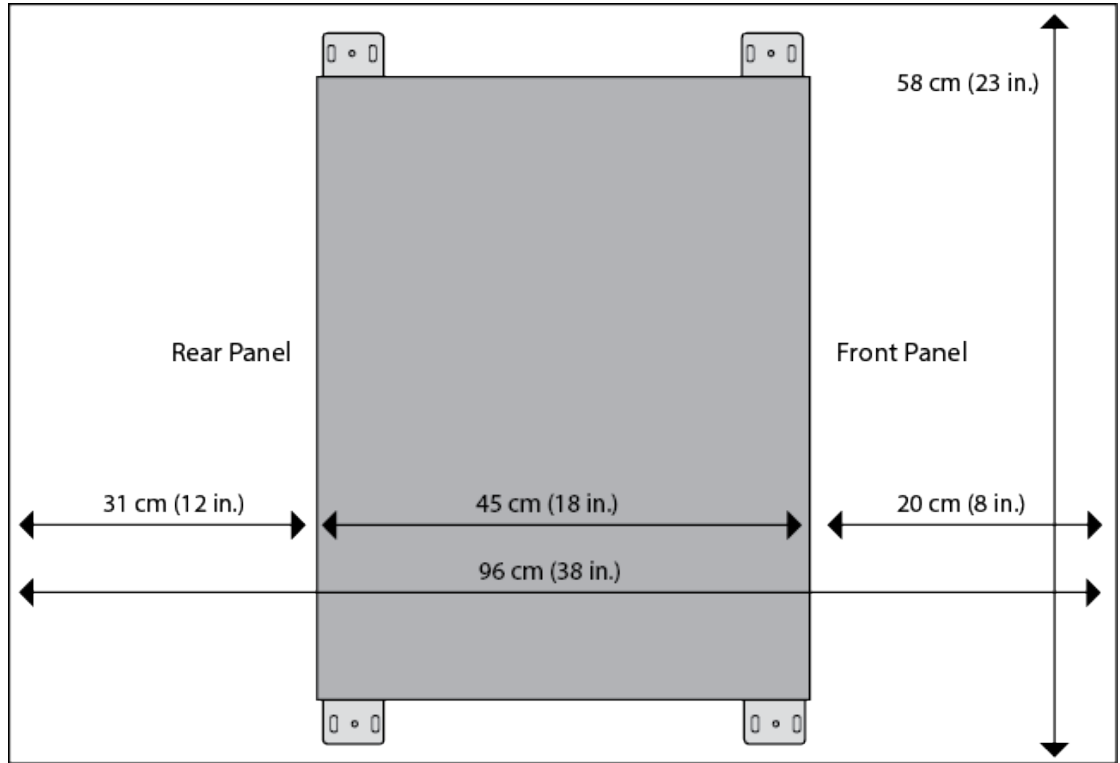

Figure 92. Minimum Wall Area Dimensions with the Front Panel on the Right

Plywood Base for a Wall with Wooden Studs

If you are installing the switch on a wall that has wooden studs, Allied Telesis recommends using a plywood base for the device. (A plywood base is not required for a concrete wall.) Refer to Figure 93.

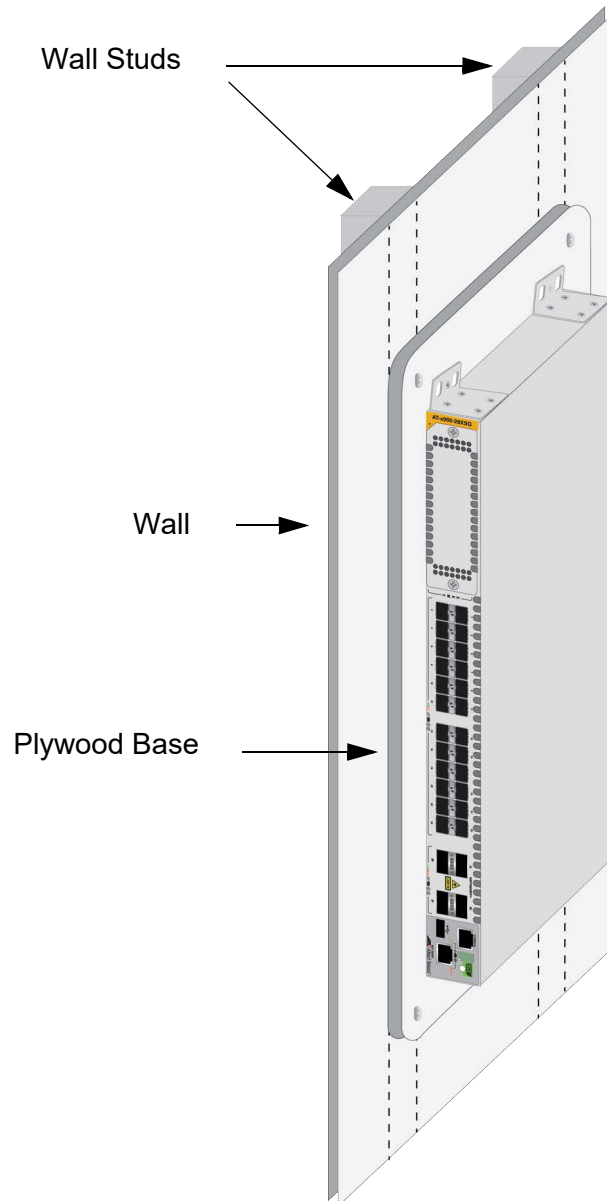

Figure 93. Switch on the Wall with a Plywood Base

The plywood base allows you to mount the switch on two wall studs. Without the base, only one side of the switch would be attached to a stud. This is because the standard distance between two studs in a wall is 41 centimeters (16 inches) while the distance between the left and right brackets on the switch is 37 centimeters (14-1/2 inches).

The recommended minimum dimensions of the plywood base are listed here:

- ❑ Width: 58.4 centimeters (23 inches)
- ❑ Height: 55.9 centimeters (22 inches)
- ❑ Thickness: 5.1 centimeters (2 inches)

The dimensions assume the wall studs are 41 centimeters (16 inches) apart. You may need to adjust the width of the base if the distance between the studs in your wall is different than the industry standard.

You should install the plywood base to the wall and then install the switch on the base. Refer to Figure 94.

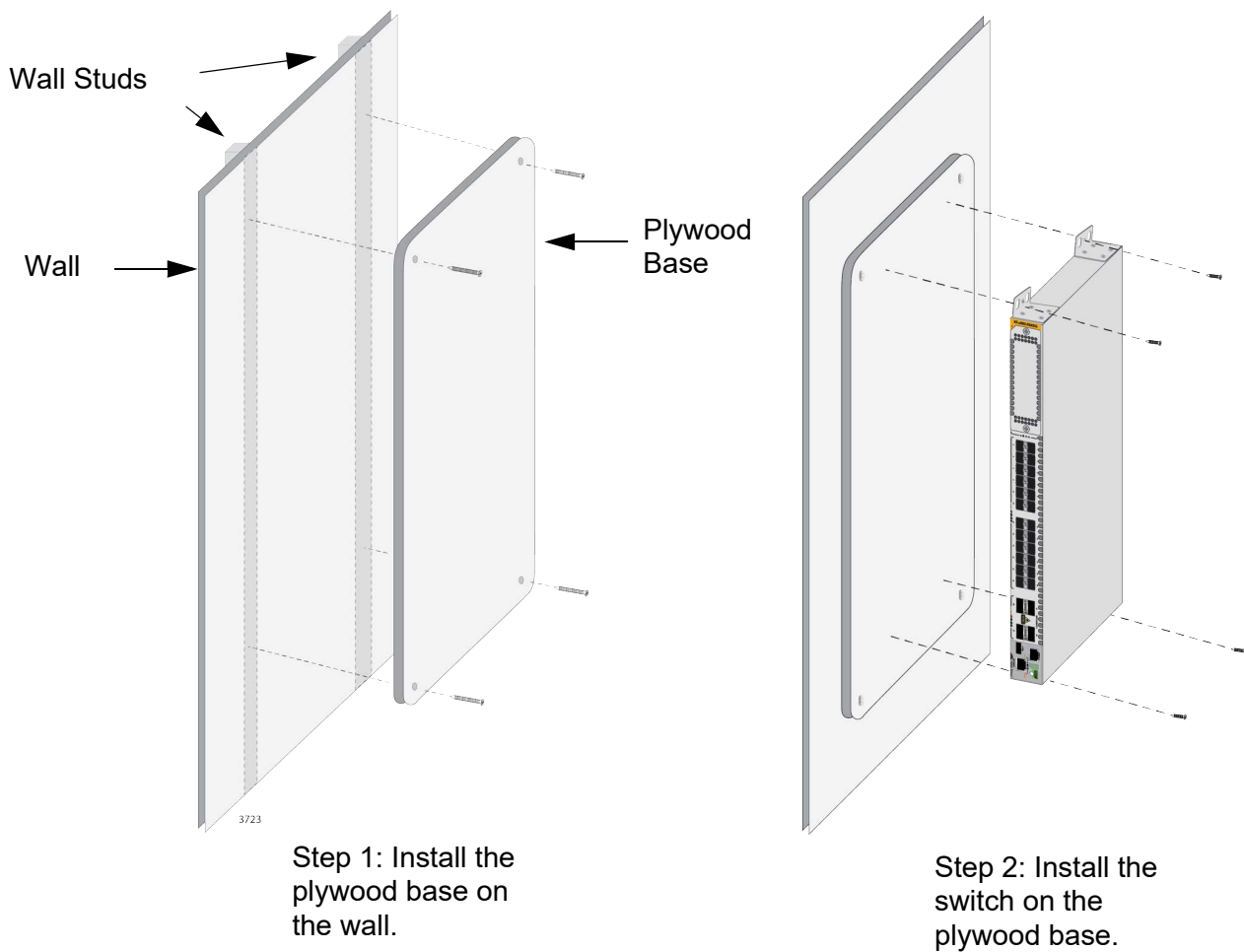

Figure 94. Steps to Installing the Switch with a Plywood Base

Installation Guidelines

Here are the guidelines to installing the switch on a wall:

- ❑ You may install the switch on a wall that has wooden studs.
- ❑ You may install it on a concrete wall.
- ❑ If you are installing the switch on a wall with wooden studs, you should use a plywood base to support the switch. For more information, refer to “Plywood Base for a Wall with Wooden Studs” on page 161. A plywood base is not required for a concrete wall.
- ❑ You should not install the switch on a wall that has metal studs. Metal studs may not be strong enough to safely support the device.
- ❑ You should not install the switch only on sheetrock or similar material. Sheetrock is not strong enough to safely support the device.
- ❑ You should install the power supplies and optional XEM2 Line Card before installing the switch on a wall. For instructions, refer to “Installing AT-PWR600 and AT-PWR600R AC Power Supplies” on page 128 and “Installing XEM2 Ethernet Line Cards” on page 141.



Warning

The device is heavy. Always ask for assistance before moving or lifting it to avoid injuring yourself or damaging the equipment.

 E122



Warning

The device should be installed on a wall by a qualified building contractor. Serious injury to yourself or others or damage to the equipment may result if it is not properly fastened to the wall.

 E105

Note

Depending on your installation, it may be easier to install the power supplies and optional XEM2 Line Card before installing the switch on the wall.

Tools and Material

Here are the required tools and material for installing the switch on a wall:

- ❑ Four standard brackets and sixteen M3-6mm screws (included with the switch) listed in Table 38 on page 121.
- ❑ Four wood or concrete wall screws (included with the switch)
- ❑ Four concrete wall anchors (included with the switch)
- ❑ Cross-head screwdriver (not provided)
- ❑ Stud finder for a wooden wall, capable of identifying the middle of wall studs and hot electrical wiring (not provided)
- ❑ Drill and 1/4-inch carbide drill bit for a concrete wall (not provided)
- ❑ Plywood base if you are installing the switch on a wall with wooden studs (not provided.) Refer to “Plywood Base for a Wall with Wooden Studs” on page 161 for illustrations.
- ❑ Four screws and anchors for attaching the plywood base to the wall (not provided)



Caution

The supplied screws and anchors may not be appropriate for all walls. A qualified building contractor should determine the hardware requirements for your wall before installing the switch. *ES* E88

Installing the Plywood Base

A plywood base is recommended when installing the switch on a wall that has wooden studs. Refer to “Plywood Base for a Wall with Wooden Studs” on page 161. Consult a qualified building contractor for installation instructions for the plywood base. The installation guidelines are listed here:

- ❑ You should use a stud finder to identify the middle of studs and hot electrical wiring in the wall.
- ❑ You should attach the base to two wall studs with a minimum of four screws.
- ❑ The selected wall location for the base should adhere to the recommendations in “Choosing a Site for the Chassis” on page 116 and “Recommended Minimum Wall Area Dimensions” on page 159.

Installing the Switch on the Plywood Base

This procedure assumes that the plywood base for the switch is already installed on the wall. Please review “Reviewing Safety Precautions” on page 110 and “Choosing a Site for the Chassis” on page 116 before performing this procedure. Allied Telesis recommends a minimum of three people for this procedure.



Warning

The device is heavy. Always ask for assistance before moving or lifting it to avoid injuring yourself or damaging the equipment.

⚡ E122



Warning

The device should be installed on the wall by a qualified building contractor. Serious injury to yourself or others or damage to the equipment may result if it is not properly fastened to the wall.

⚡ E105

Allied Telesis recommends installing the power supplies and optional XEM2 Line Card before installing the switch on a wall. For instructions, refer to “Installing AT-PWR600 and AT-PWR600R AC Power Supplies” on page 128 and “Installing XEM2 Ethernet Line Cards” on page 141.

To install the switch on the plywood base, perform the following procedure:

1. Place the switch in a table.
2. Install the four brackets with the sixteen screws that come with the switch to the sides of the unit, as shown in Figure 95.



Figure 95. Installing the Brackets to the Switch for Wall Installation

The sides of the switch have two sets of holes. One set is for installing the switch on a wall with the brackets and the other is for the RKMT-SL01 Rack Mounting Kit. For this procedure, you need to use the bracket holes, identified in Figure 84 on page 150.

3. After attaching the brackets to the side of the switch, have two people hold the switch on the plywood base on the wall while you secure it with the four provided screws. Refer to Figure 96.

Please follow these guidelines as you position the switch on the wall:

- ❑ Position the switch so that the front panel is either on the left or the right. Refer to Figure 90 on page 158. You may not install the switch with the front panel facing up or down.
- ❑ Leave sufficient space from other devices or walls so that you can access the front and back panels. Refer to “Recommended Minimum Wall Area Dimensions” on page 159.

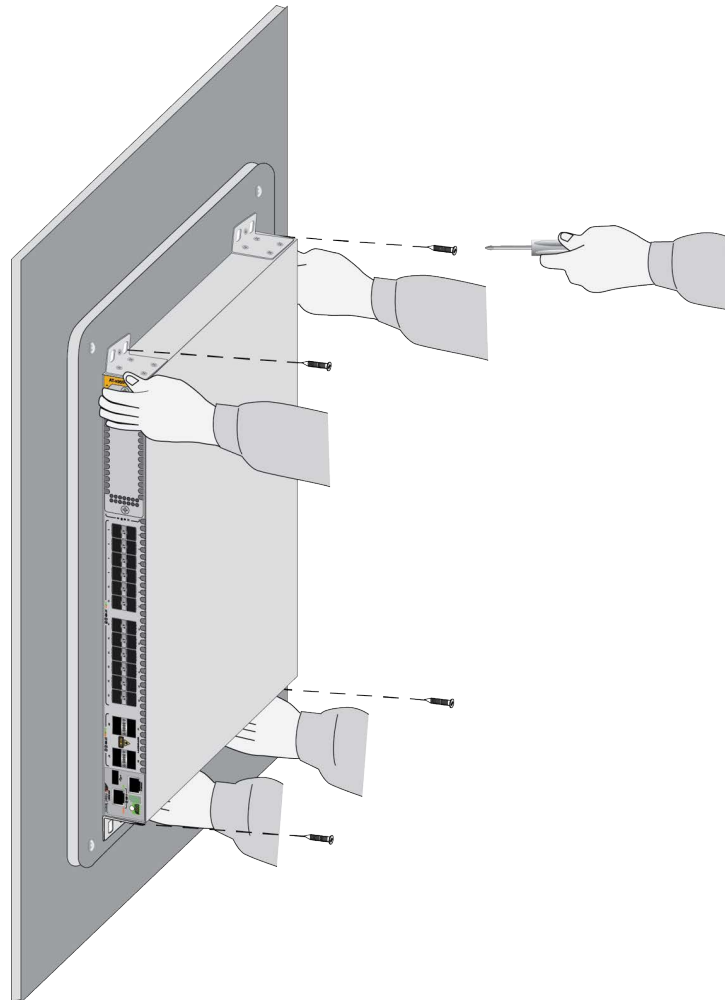

Figure 96. Attaching the Switch to the Plywood Base

4. Do one of the following:
 - ❑ To install the power supplies, go to “Installing AT-PWR600 and AT-PWR600R AC Power Supplies” on page 128.
 - ❑ To install an optional XEM2 Ethernet Line Card, go to “Installing XEM2 Ethernet Line Cards” on page 141.
 - ❑ After installing the switches of the stack, go to Chapter 10, “Configuring the Master Switch” on page 197.

Installing the Switch on a Concrete Wall

Allied Telesis recommends a minimum of three people for this procedure. To install the switch on a concrete wall, perform the following procedure:



Warning

The device is heavy. Always ask for assistance before moving or lifting it to avoid injuring yourself or damaging the equipment.

 E122



Warning

The device should be installed on a wall by a qualified building contractor. Serious injury to yourself or others or damage to the equipment may result if it is not properly fastened to the wall.

 E105

Allied Telesis recommends installing the power supplies and optional XEM2 Line Card before installing the switch on a wall. For instructions, refer to “Installing AT-PWR600 and AT-PWR600R AC Power Supplies” on page 128 and “Installing XEM2 Ethernet Line Cards” on page 141.

1. Place the switch in a table.
2. Install the four brackets with sixteen screws that come with the switch to the sides of the unit, as shown in Figure 95 on page 166.
3. Have two people hold the switch on the concrete wall at the selected location for the device while you use a pencil or pen to mark the wall with the locations of the four screw holes in the four brackets. Refer to Figure 97 on page 170.

Please follow these guidelines as you position the switch on the wall:

- Position the switch so that the front panel is either on the left or the right. Refer to Figure 90 on page 158. You may not install the switch with the front panel facing up or down.
- Leave sufficient space from other devices or walls so that you can access the front and back panels. Refer to “Recommended Minimum Wall Area Dimensions” on page 159.

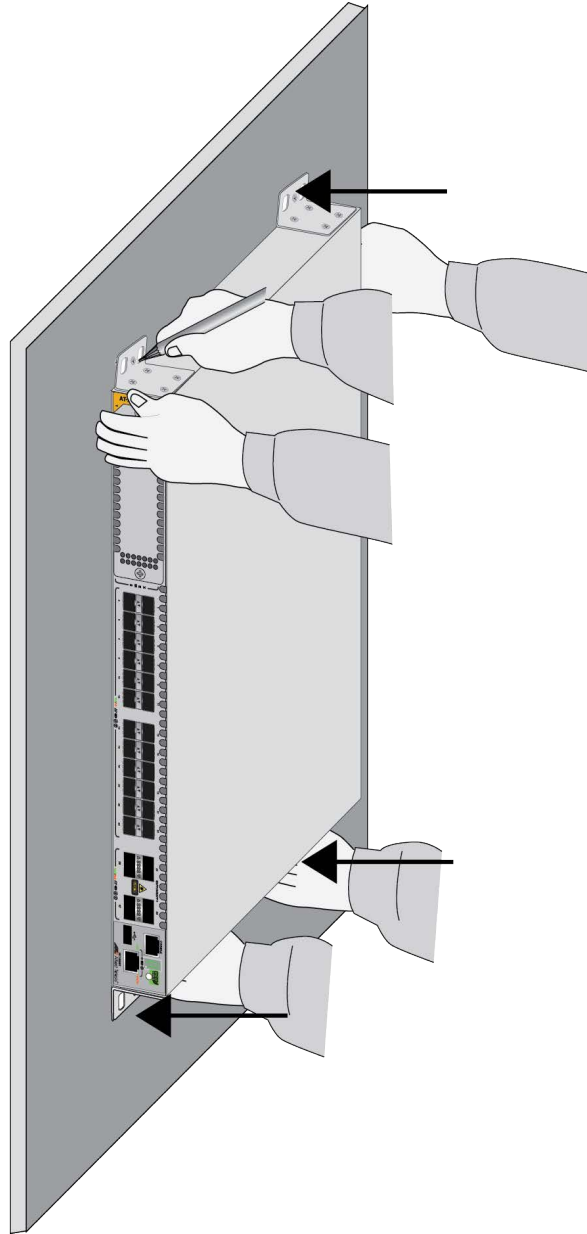

Figure 97. Marking the Locations of the Bracket Holes on a Concrete Wall

4. Place the switch on a table or desk.
5. Use a drill and 1/4-inch carbide drill bit to pre-drill the four holes you marked in step 3. Please review the following guidelines:
 - ❑ Prior to drilling, set the drill to hammer and rotation mode. The modes break up the concrete and clean out the hole.
 - ❑ Allied Telesis recommends cleaning out the holes with a brush or compressed air.

6. Insert the four anchors into the holes.
7. Have two people hold the switch at the selected wall location while you secure it to the wall with the four provided screws. Refer to Figure 98.

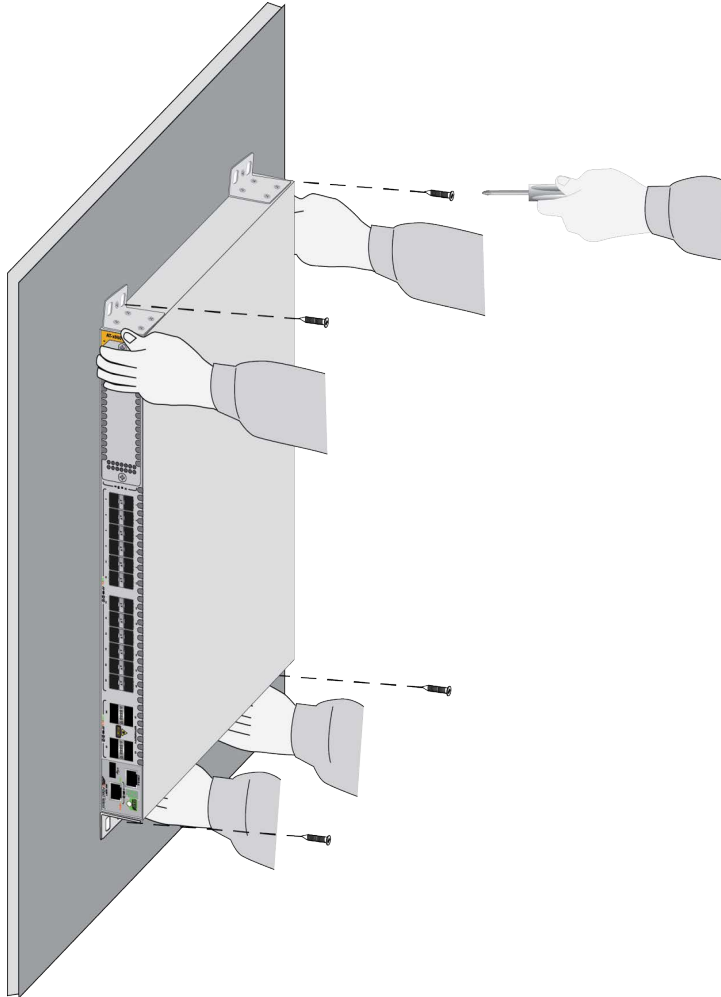

Figure 98. Installing the Switch on a Concrete Wall

8. Do one of the following:
 - To install the power supplies, go to “Installing AT-PWR600 and AT-PWR600R AC Power Supplies” on page 128.
 - To install an optional XEM2 Ethernet Line Card, go to “Installing XEM2 Ethernet Line Cards” on page 141.
 - After installing the switches of the stack, go to Chapter 10, “Configuring the Master Switch” on page 197.

Chapter 9

Installing the Switch in the RKMT-SL01 Sliding Rack

This appendix contains the following sections:

- “Introduction” on page 174
- “Rack Mount Kit Components” on page 175
- “Equipment Rack Requirements” on page 177
- “Reviewing Safety Precautions” on page 178
- “Installation Overview” on page 180
- “Unpacking the Shipping Container” on page 181
- “Installing the Outer Rails on the Equipment Rack” on page 183
- “Installing the Extension Brackets on the Inner Rails” on page 185
- “Installing the Inner Rails on the Switch” on page 191
- “Installing the Switch in the Equipment Rack” on page 193

Introduction

The RKMT-SL01 Rack Mount Kit is a slide-rail type rack-mount kit for Allied Telesis switches in EIA standard 19-inch equipment racks. The kit makes installation and maintenance of network equipment easier by letting you slide switches into or out of equipment racks, including server racks with deep dimensions.

Note

The RKMT-SL01 Kit should only be used with approved Allied Telesis products.

Rack Mount Kit Components

The kit has three main components.

Adjustable Outer Rails

Two adjustable outer rails attach to the equipment rack. They are suitable for racks with depths of 600 mm (23.6 in) to 900 mm (35.4 in). Refer to Figure 99.

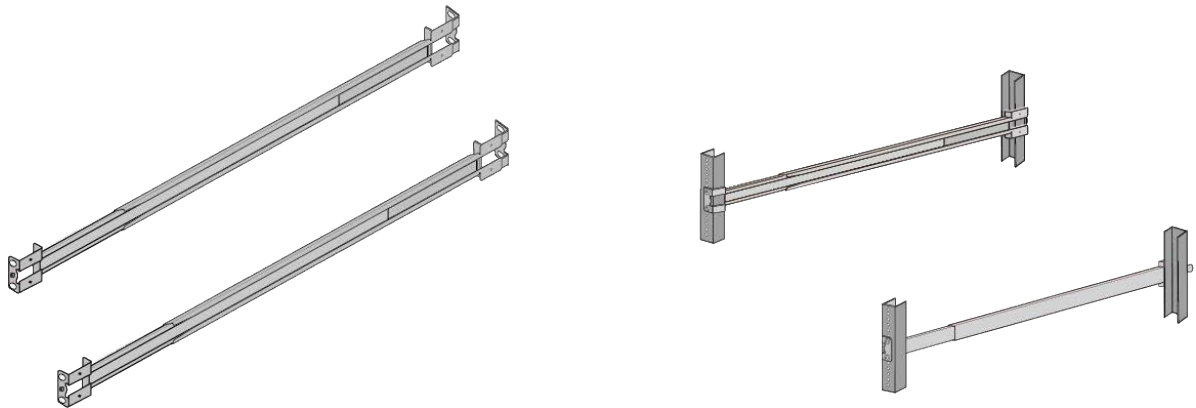

Figure 99. Outer Rails

Inner Rails

Two Inner rails attach to the sides of the switch. Refer to Figure 100.

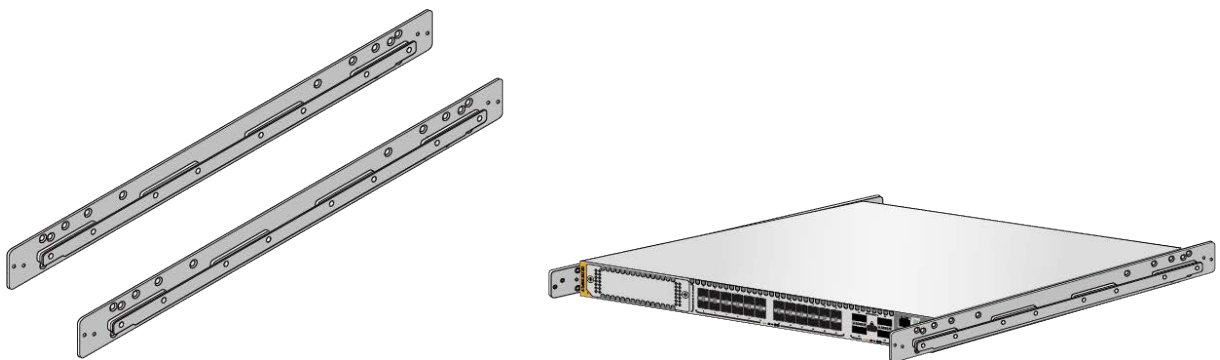

Figure 100. Inner Rails

Extension Brackets

Two extension brackets attach to the front of the inner rails and control the amount the switch is recessed in the equipment rack. The brackets also have a captive screw for securing the switch in the equipment rack. Refer to Figure 101 on page 176.

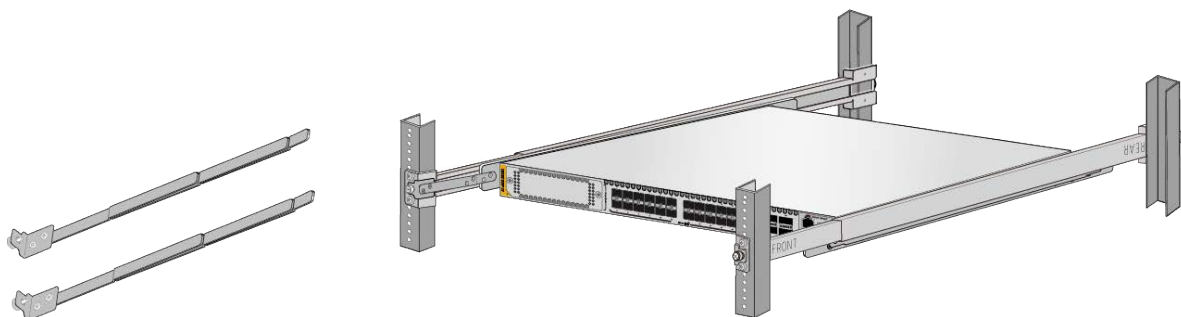

Figure 101. Extension Brackets

Equipment Rack Requirements

The Rack Mount Kit is designed for equipment racks that meet the following requirements:

- ❑ The depth can be from 600 mm (23.6 in) to 900 mm (35.4 in).
- ❑ The width should be a minimum of 452 mm (17.8 in).
- ❑ There should be 35 mm (1.4 in) depth within the rack post for the outer rail mounting.
- ❑ The distance between the left and right wall (for the outer rail mounting) should be a minimum of 10 mm (0.4 in) from the screw hole in the center of the rack posts.

Reviewing Safety Precautions

Review these safety precautions before installing the RKMT-SL01 Kit.

Note

The  indicates that a translation of the safety statement is available in a PDF document titled **Translated Safety Statements** posted on the Allied Telesis website at www.alliedtelesis.com/support.



Warning

Mounting of the equipment in the rack should be such that a hazardous condition is not created due to uneven mechanical loading.  E25



Warning

Do not pull the rear of the switch out past the front rack posts. If you need to position the rear of the switch out past the front of the rack, you should remove it completely from the rack.  E58



Warning

Pull the switch out slowly if you must remove it from the rack for maintenance. If you pull the switch out past the front of the rack posts, or if you pull it out too quickly, there is a risk that the weight of the switch will cause the sliding rail assemblies to fail and cause the switch to fall out.  E59



Caution

Avoid applying excessive force to the cables.  E60



Caution

If using long extension bracket(s), secure between the fixed bracket and short extension bracket - the long extension bracket(s) cannot be attached directly to the inner rail.  E61

**Caution**

Use the adjustment bracket screws supplied with the inner rail. Using screws other than those supplied may result in equipment damage. *⌘* E62

**Warning**

When installing the outer and inner rails, and adjustment bracket, ensure the components are securely attached with the appropriate screws. If not securely attached, a serious accident may occur due to falling equipment. *⌘* E63

**Warning**

When installing and removing the switch from the rack, disconnect the media and power cables. *⌘* E64

**Warning**

A built-in stopper prevents the outer rail from extending beyond its maximum length of 960 mm (37.8 in). Do not extend the rail by force beyond this point, otherwise, the outer bracket will be weakened, and the switch may fall from the rack; equipment could be damaged. *⌘* E65

**Warning**

Ensure the front and rear of both outer rails are attached at the same distance from the floor, otherwise the switch may fall from the rack. *⌘* E66

**Warning**

Be careful to not drop the switch when lifting and not to pinch your fingers when inserting the switch into the rack. *⌘* E67

**Warning**

Other than maintenance work, secure the switch to the outer rail (via the adjustment bracket): If the switch is not secured properly, there is a risk of the switch falling out during movement caused by an earthquake. *⌘* E68

**Warning**

Do not pull the switch out past the front rack posts. *⌘* E69

Installation Overview

The following steps summarize the installation procedure for the RKMT-SL01 Rack Mount Kit:

1. Verify the contents of the shipping box. Refer to “Unpacking the Shipping Container” on page 181.
2. Attach the outer rails to the equipment rack. Refer to “Installing the Outer Rails on the Equipment Rack” on page 183.
3. Determine the lengths of the extension brackets and install the brackets on the inner rails. Refer to “Installing the Extension Brackets on the Inner Rails” on page 185.
4. Attach the inner rails to the switch. Refer to “Installing the Inner Rails on the Switch” on page 191.
5. Slide the switch into the outer rails. Refer to “Installing the Switch in the Equipment Rack” on page 193.

Unpacking the Shipping Container

The contents of the shipping container are shown in Figure 102.

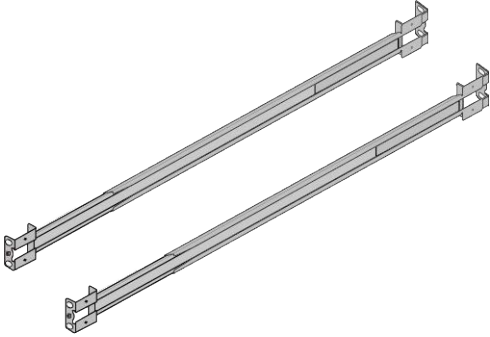

Two outer rails - They attach to the equipment rack. Their lengths are adjustable from 600 to 960 mm (23.6 - 37.8 in).

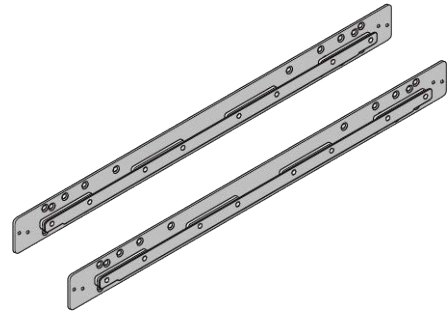

Two inner rails - They attach to the sides of the switch.

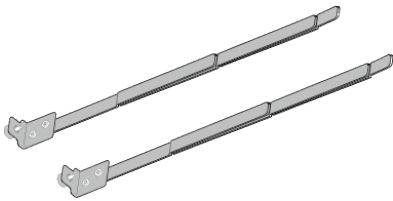

Two extension brackets - They set the distance the switch is recessed in the equipment rack and secure the switch to the rack.



- 16 inner rail screws (M4 x 8 countersunk) - They attach the inner rails to the switch. Screw holes and number of screws vary depending on the switch.
- Four extension bracket screws (M3 x 4 countersunk) - They attach the extension brackets to the inner rails.

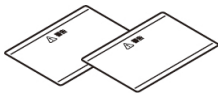

Two warning labels - They are affixed to the top and bottom of the switch and warn against pulling the switch out past the equipment rack posts.

Figure 102. Shipping Container Contents

Note

Store the packaging material in a safe location. You should use the original shipping material if you need to return the kit to Allied Telesis.



Warning

When installing the outer and inner rails, and extension brackets, ensure the components are securely attached with the appropriate screws. If not securely attached, a serious accident may occur due to falling equipment. ⚡ E63

Installing the Outer Rails on the Equipment Rack

To install the outer rails to the equipment rack, perform the following procedure.

1. Locate the FRONT and REAR labels on the sides of the rails. You have to install the rails with the FRONT labels at the front of the equipment rack and the REAR Labels at the back. Refer to Figure 103.



Figure 103. FRONT and REAR Labels on the Outer Rails

2. Attach the outer rails to the equipment rack using the supplied screws. Use four screws per rail. Refer to Figure 104 on page 184. Installing the switch can be easier if you leave the screws slightly loosened now and fully tightened them after the switch is installed.



Warning

Built-in stoppers prevent the outer rails from extending beyond their maximum length of 960 mm (37.8 in). Do not force the rails beyond the maximum length. Otherwise, the brackets will be weakened, and the switch may fall from the rack and be damaged. ⚠ E65



Warning

Verify that the front and rear of both outer rails are attached at the same distance from the floor, otherwise the switch may fall from the rack. ⚠ E66

3. Go to “Installing the Extension Brackets on the Inner Rails” on page 185.

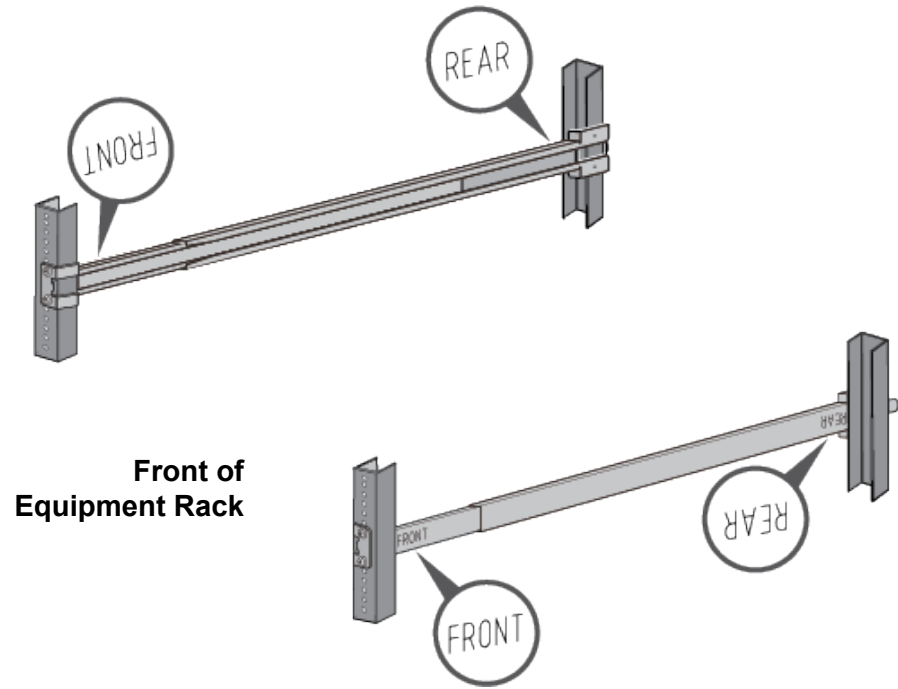

Figure 104. Installing the Outer Rails on the Equipment Rack

Installing the Extension Brackets on the Inner Rails

The kit comes with two extension brackets. Refer to Figure 105.

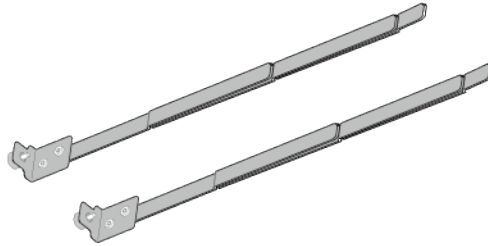

Figure 105. Extension Brackets

You use the brackets to recess the switch in the equipment rack. The maximum distance will depend on the depth of the rack. The deeper the equipment rack, the more the switch can be recessed. The range is approximately 40mm (1.6 in.) to 453mm (17.8 in.). Figure 106 is an example.

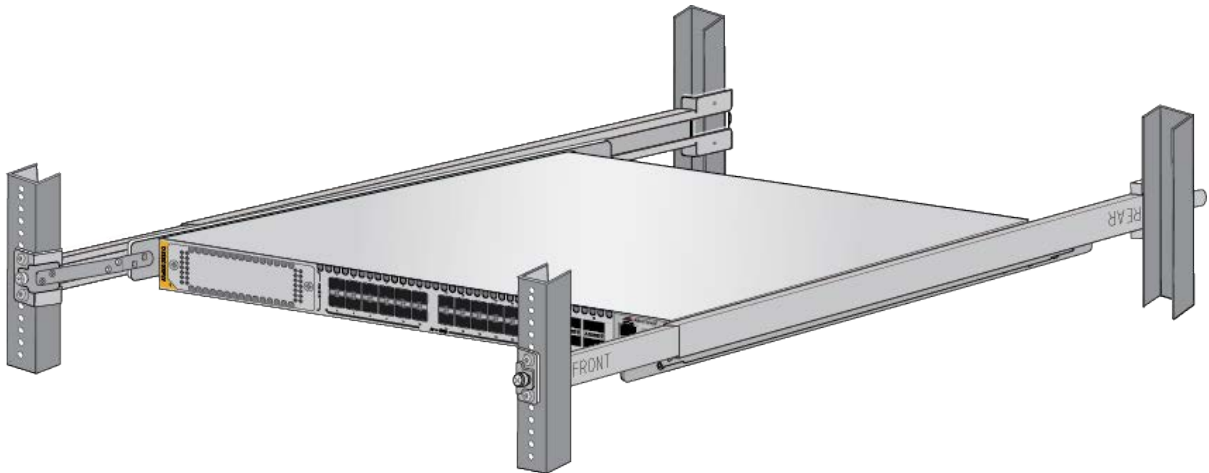

Figure 106. Example of a Switch Recessed in an Equipment Rack

Measuring the Extension Bracket Lengths

The first step is to decide how much you want to recess the front panel of the switch in the rack and then measure the distance. That will tell you the approximate lengths of the extension brackets. Perform the following procedure:

1. Slide one of the inner rails into an outer rail. Be sure that the UP arrow on the inner rail is pointing up. Refer to Figure 107 on page 186.

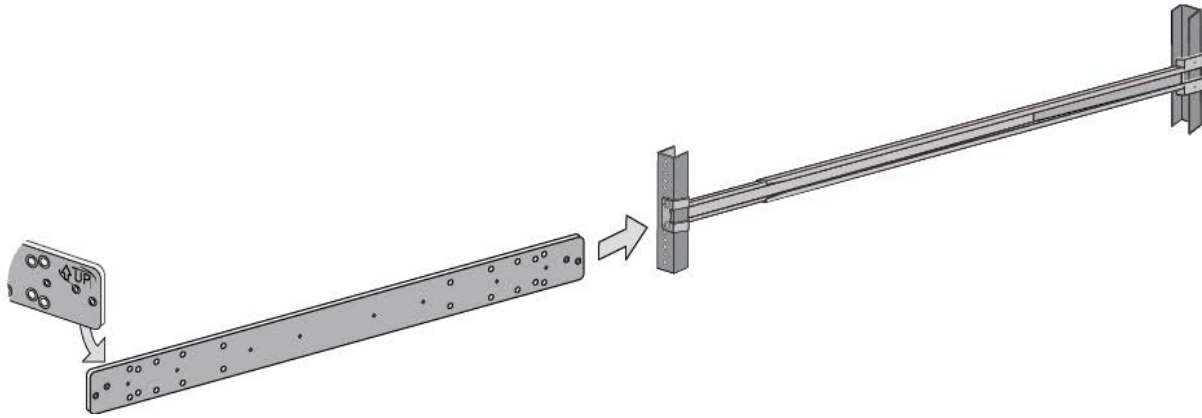

Figure 107. Inserting an Inner Rail into an Outer Rail

2. Position the inner rail at the planned location for the front panel of switch in the sliding rack. Refer to Figure 108.

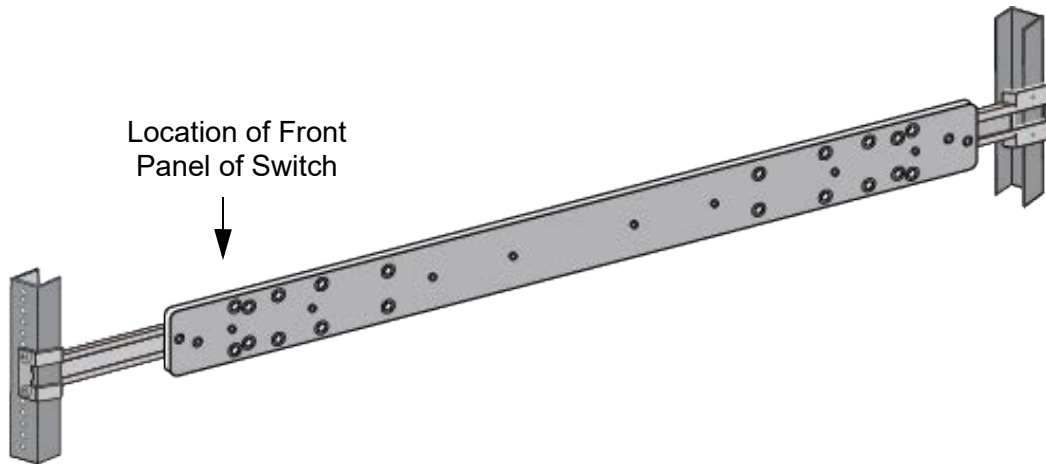

Figure 108. Example of Positioning the Inner Rail

3. Measure the distance from the front of the equipment rack to the front of the inner rail. This will be the approximate length of the extension brackets. Refer to Figure 109.

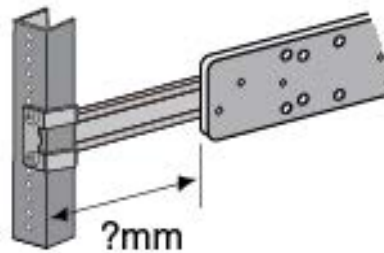

Figure 109. Measuring for the Extension Brackets

- Remove the inner rail from the outer rail. Refer to Figure 110.

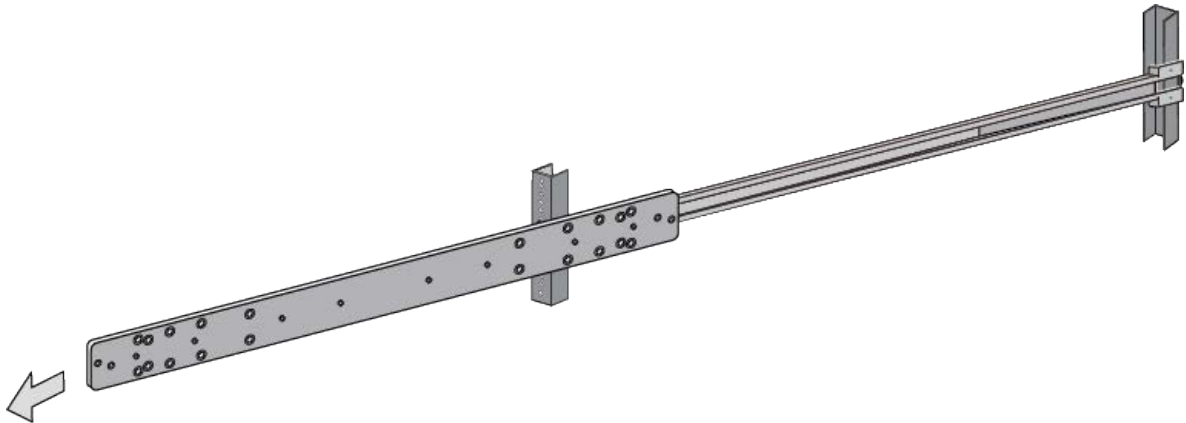

Figure 110. Removing the Inner Rail

- Go to “Assembling the Extension Brackets,” next.

Assembling the Extension Brackets

Now that you know the approximate length for the extension brackets, you are ready to assemble them. The brackets consist of four parts. Refer to Table 40 and Figure 111.

Table 40. Extension Bracket Parts

A	Fixed Bracket	1 ea
B	Long Extension Brackets	2 ea
C	Short Extension Bracket	1 ea

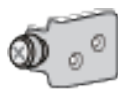

A - Fixed Bracket

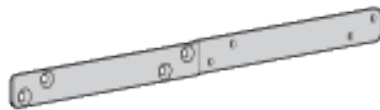

B - Long Extension Bracket

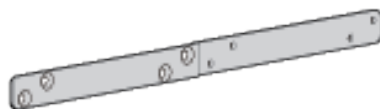

B - Long Extension Bracket



C - Short Extension Bracket

Figure 111. Extension Bracket Parts

You adjust the lengths of the brackets by connecting them in different combinations. There are seven possible configurations. Refer to Figure 112. The default configuration is number 5. To adjust the extension brackets, perform the following procedure:

1. Review Figure 112 to find the bracket length that most closely matches the measurement taken in step 3 in the previous procedure.

#1

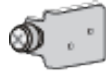

#2

Length:101mm (3.8 in.)

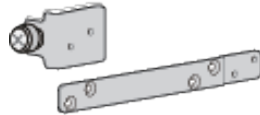

#3

Length:202mm (8.0 in.)

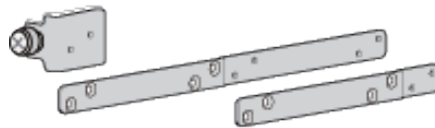

#4

Length:277mm (10.9 in.)

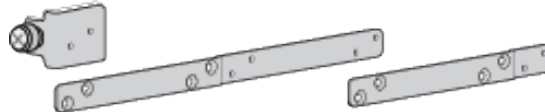

#5

Length:303mm (11.9 in.)
(Factory default)

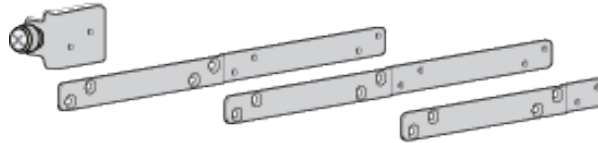

#6

Length:378mm (14.9 in.)

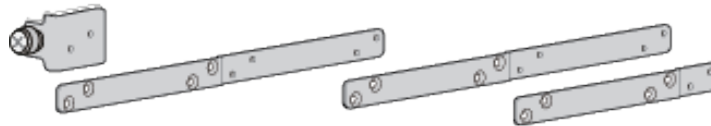

#7

Length:453mm (17.8 in.)

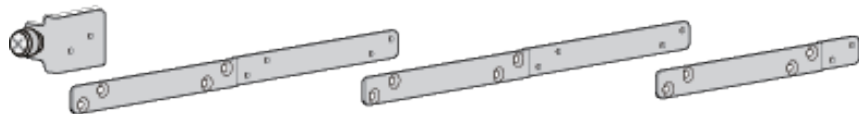

Figure 112. Extension Bracket Configurations

Note

The long brackets have to be used between the fixed and short brackets. You cannot connect them directly to the inner rails.

2. Assemble the extension brackets to match the selected length in the table.
3. Attach the extension brackets to the inner rails. Observe the following:
 - Attach the brackets to the sides of the inner rails with the UP arrows.
 - Attach the screws through the holes on the sides opposite the sides with the UP arrows.

**Caution**

Use the extension bracket screws supplied with the inner rail. Using screws other than those supplied may result in equipment damage.

⚡ E62

Figure 113 on page 189 shows an example.

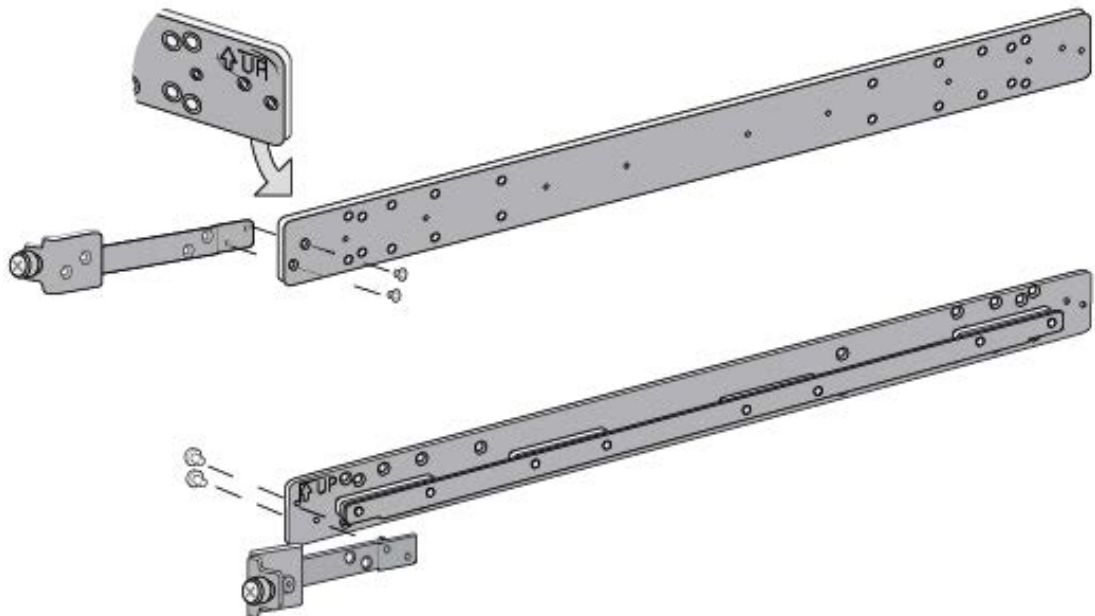

Figure 113. Example of Attaching the Extension Brackets to the Inner Rails

4. To test the lengths of the extension brackets, slide the inner rails into the outer rails in the equipment rack. Refer to Figure 114.

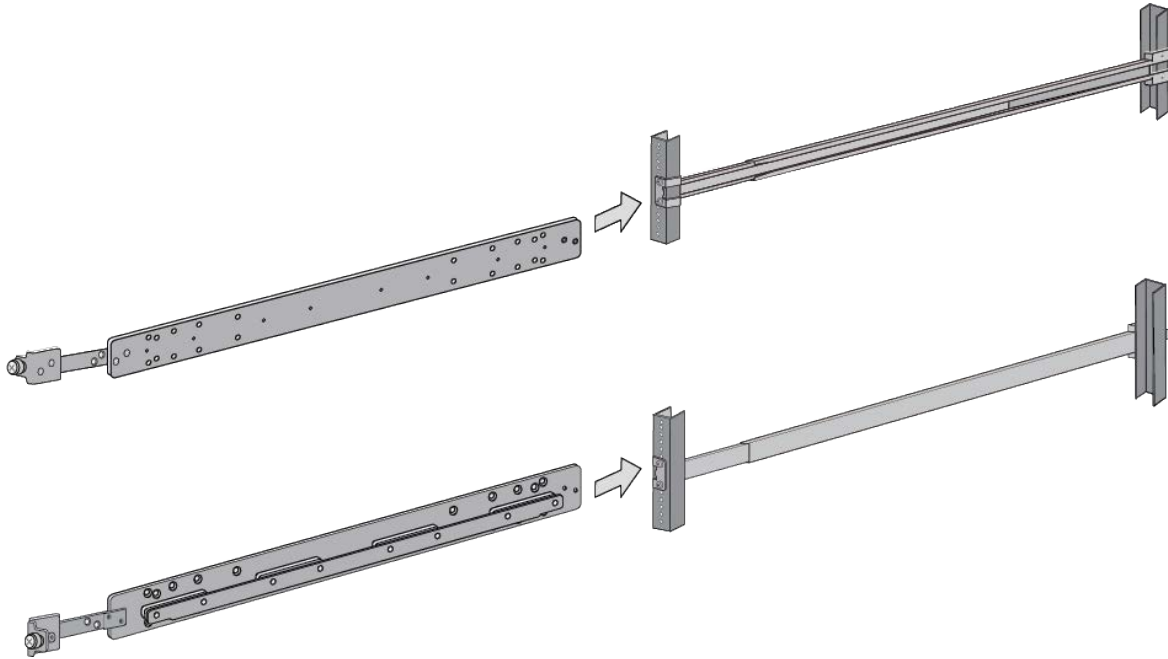

Figure 114. Testing the Inner Rails with the Extension Brackets

5. Measure the distance from the front of the equipment rack to the front of the inner rail. Refer to Figure 115. This should approximately match the value you measured in “Measuring the Extension Bracket Lengths” on page 185.

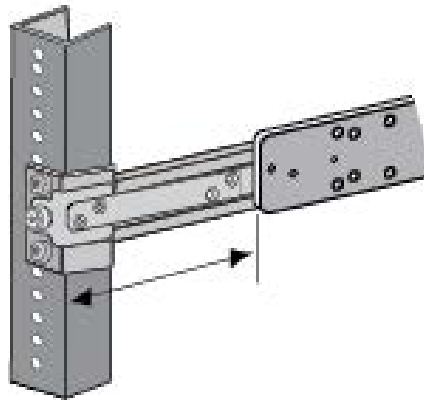

Figure 115. Verifying the Length of the Extension Bracket

6. If the extension brackets are the correct length, remove the inner brackets from the outer brackets and go to “Installing the Inner Rails on the Switch” on page 191.
7. If the brackets are not the correct length, repeat this procedure.

Installing the Inner Rails on the Switch

The sides of the x950 Switches have two sets of bracket screw holes. The smaller M3 holes are for the standard brackets that come with the switch and the larger M4 screw holes are for the inner rails of the RKMT-SL01 sliding rack. The inner rails are attached to the switch with four M4 screws on each side.

Figure 116 identifies the screw holes on the sides of the AT-x950-28XSQ and AT-x950-28XTQm Switches and inner rails.

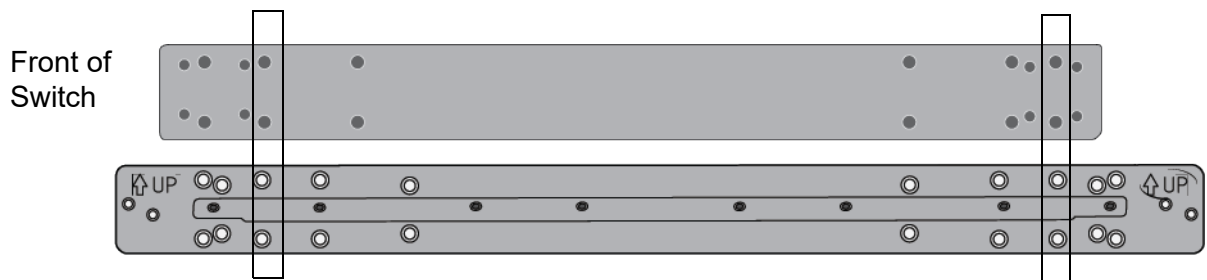

Figure 116. Inner Rail Screw Holes on the AT-x950-28XSQ and AT-x950-28XTQm Switches

Figure 117 identifies the screw holes on the sides of the AT-x950-52XSQ and AT-x950-52XTQm Switches and inner rails.

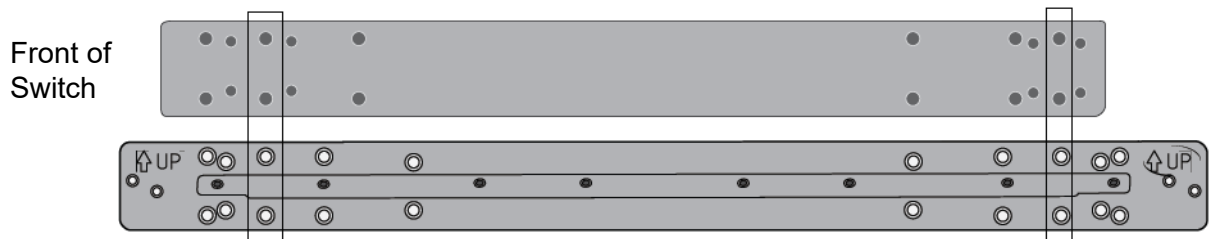

Figure 117. Inner Rail Screw Holes on the AT-x950-52XSQ and AT-x950-52XTQm Switches

Attach the inner rails to the switch using eight M4 screws included with the sliding rack. Be sure that the UP arrows on the rails are pointing up and that the extension brackets extend in front of the switch. Refer to Figure 118 on page 192.

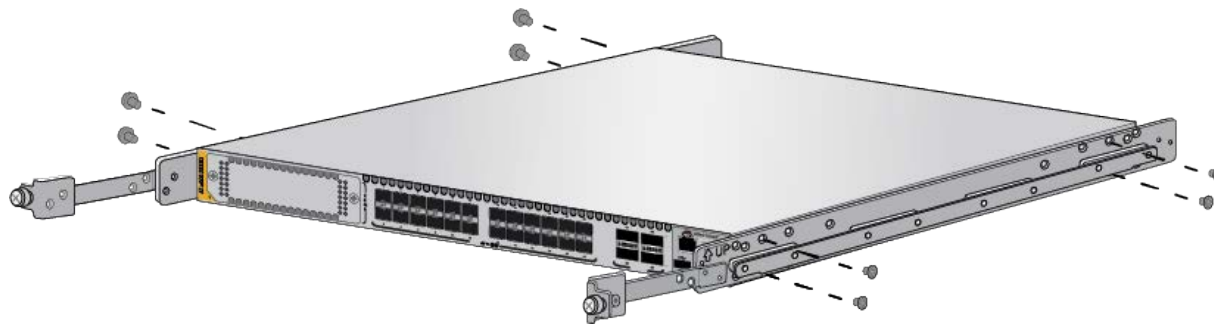

Figure 118. Attaching the Inner Rails to the x950 Switch

Go to “Installing the Switch in the Equipment Rack” on page 193.

Installing the Switch in the Equipment Rack

After attaching the inner rails and extension brackets to the switch, perform the following procedure to install the switch in the sliding rack:



Warning

When installing or removing the switch from the rack, disconnect the media and power cables. ⚡ E64

1. Install the switch in the sliding rack by sliding the inner rails into the outer rail grooves. Refer to Figure 119.

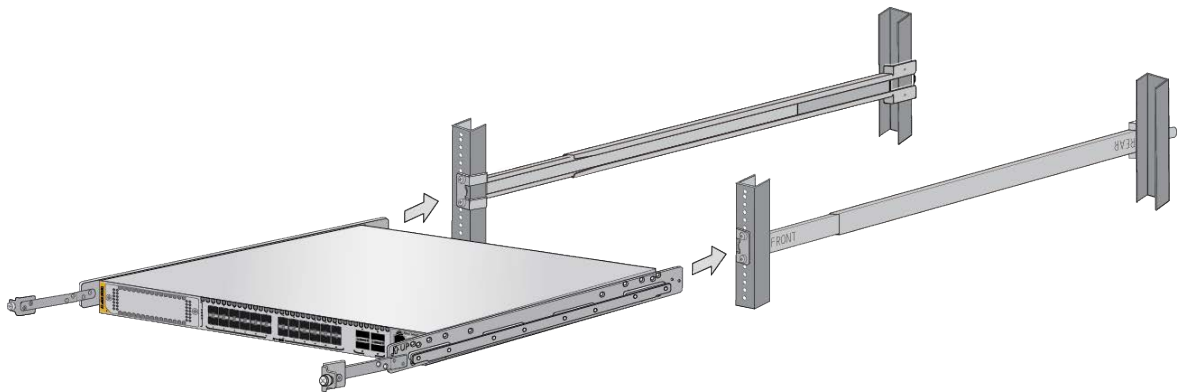

Figure 119. Sliding the Inner Rails on the Switch into the Outer Rails



Warning

Be careful to not drop the switch or pinch your fingers when inserting it into the sliding rack. ⚡ E67

2. Affix the provided warning labels to the top and bottom of the switch, in locations immediately visible when removing the device from the rack. Refer to Figure 120 on page 194.

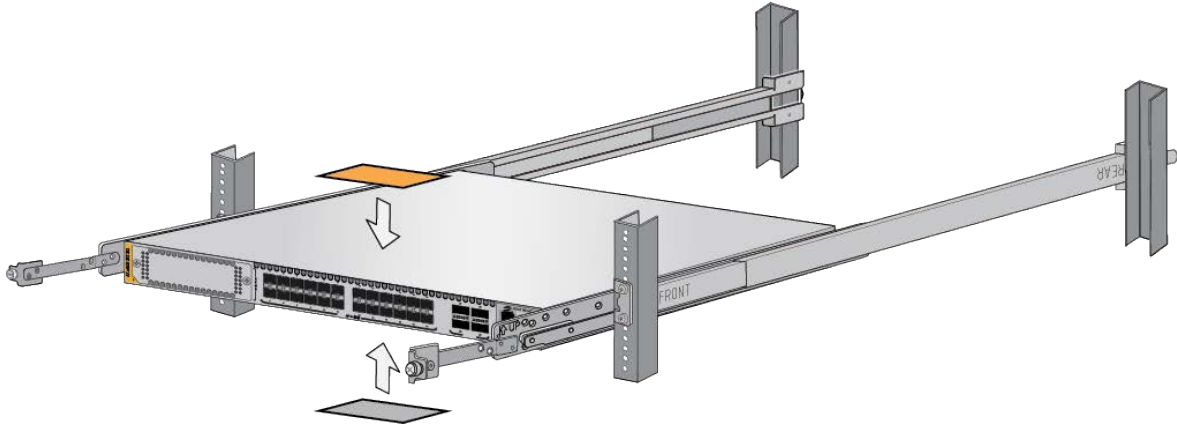

Figure 120. Affixing the Warning Labels

3. Slide the switch fully into the rack.
4. Tighten the two screws on the fixed brackets to secure the switch to the equipment rack. Refer to Figure 121.

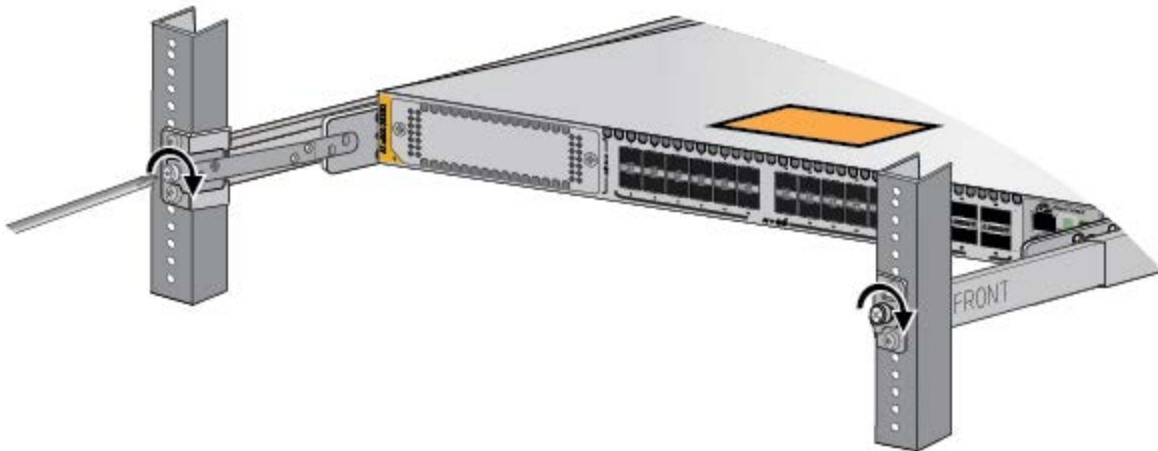

Figure 121. Tightening the Two Screws on the Fixed Brackets



Warning

Always be sure to secure the switch to the outer rail (via the adjustment bracket). If the switch is not secured properly, there is a risk of it falling out during an earthquake. ⚡ E68



Warning

Do not pull the switch out past the front rack posts. ⚡ E69

**Warning**

Pull the switch out slowly if you must remove it from the rack for maintenance. If you pull the switch out past the front of the rack posts, or if you pull it out too quickly, there is a risk that the weight of the switch will cause the sliding rail assemblies to fail and cause the switch to fall out. ⚡ E59

5. Finish tightening the eight screws on the outer rails to secure the rails to the equipment rack. See Figure 122.

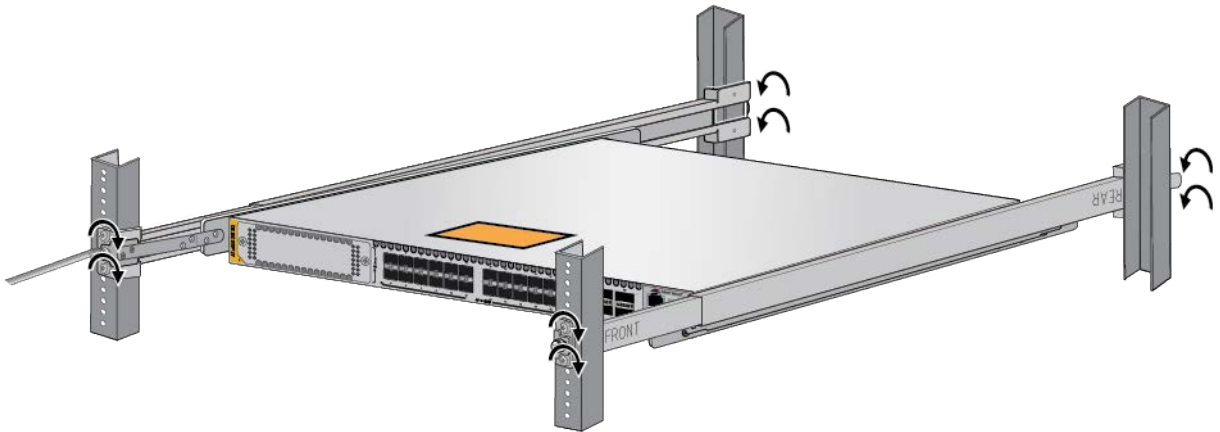

Figure 122. Tightening the Screws on the Outer Rails

This completes the installation procedure.

Chapter 10

Configuring the Master Switch

This chapter contains the following sections:

- ❑ “Command Summary” on page 198
- ❑ “Powering On a Switch” on page 202
- ❑ “Starting a Local Management Session” on page 206
- ❑ “General Steps for the Master Switch” on page 208
- ❑ “Configuring the Master Switch - Part I” on page 210
- ❑ “Configuring the Master Switch - Part II” on page 213
- ❑ “Verifying the Master Switch” on page 216
- ❑ “What to Do Next” on page 218

Command Summary

The following sections briefly describe the commands for configuring the master and member switches for stacking. For further instructions, refer to the *Software Reference for x950 Switch, AlliedWare Plus Operating System* and *Virtual Chassis Stacking (VCStack) Feature Overview and Configuration Guide*. After reviewing the commands, go to “General Steps for the Master Switch” on page 208 to begin the configuration procedures.

PLATFORM PORTMODE INTERFACE

This command is used to configure ports 25, 29, 33, 37 on the AT-x950-28XSQ and AT-x950-28XTQm Switches and ports 49, 53, 57, 61 on the AT-x950-52XSQ and AT-x950-52XTQm Switches for the following types of transceivers and cables:

- ❑ 40G QSFP+ transceivers
- ❑ 100G QSFP28 transceivers
- ❑ 40G to 4x10G breakout cables

Note

You must reset the switch after designating ports for 100G transceivers or after replacing 100G transceivers with 40G transceivers or breakout cables.

Allied Telesis recommends configuring these ports during the initial configuration procedure even if they will not be used for the stack trunk.

The command format is shown here:

```
platform portmode interface ports 10gx4|40g|100g
```

The variables are defined here:

- ❑ The PORTS variable specifies the ports to be configured:
 - The possible ports on the AT-x950-28XSQ and AT-x950-28XTQm Switches are PORT*n*.0.25, PORT*n*.0.29, PORT*n*.0.33, PORT*n*.0.37.
 - The possible ports on the AT-x950-52XSQ and AT-x950-52XTQm Switches are PORT*n*.0.49, PORT*n*.0.53, PORT*n*.0.57, and PORT*n*.0.61.

The “*n*” variable is the switch’s ID.

- ❑ The “10gx4” parameter configures ports for 4x10G breakout cables.
- ❑ The “40g” parameter configures ports for 40G QSFP+ transceivers. This is the default setting.

- ❑ The “100g” parameter configures ports for 100G QSFP28 transceivers.

This example configures ports 33 and 37 on AT-x950-28XSQ and AT-x950-28XTQm Switches for 100G QSFP28 transceivers:

```
awplus(config)# platform portmode interface
port1.0.33,port1.0.37 100g
```

This example configures port 25 on AT-x950-28XSQ and AT-x950-28XTQm Switches for a breakout cable:

```
awplus(config)# platform portmode interface port1.0.25
10gx4
```

This example restores the default setting of 40G QSFP+ transceivers on ports 49 and 53 on AT-x950-52XSQ and AT-x950-52XTQm Switches:

```
awplus(config)# platform portmode interface
port1.0.49,port1.0.53 40g
```

For background information on port numbering, refer to “Designating Ports in the Command Line Interface” on page 54.

STACKPORT

You use this command to designate the ports of the stack trunk. The command has to be performed after you have enabled the stacking feature with the STACK ENABLE command. Additionally, it has to be performed from the Interface mode of the selected ports. In this example, ports 1 to 4 on the switch with ID 1 are designated as ports of the stack trunk:

```
awplus(config)# interface port1.0.1-1.0.4
awplus(config-if)# stackport
```

This example designates ports 49 and 53 on the AT-x950-52XSQ or AT-x950-52XTQm Switch with the ID 3 as ports of the stack trunk:

```
awplus(config)# interface port3.0.49,port3.0.53
awplus(config-if)# stackport
```

The command for removing the stacking function from ports is the NO STACKPORT command. You might perform the command if you assign the stacking function to the wrong ports or decide to change the trunk ports. Like the STACKPORT command, it has to be performed from the Interface mode. This example removes the stacking function from ports 6 and 8 on the switch with ID 2:

```
awplus(config)# interface port2.0.6,port2.0.8
awplus(config-if)# no stackport
```

STACK ENABLE

This command, which is located in the Global Configuration mode, is used to activate the VCStack feature. Activating the VCStack feature requires resetting the switch. You must perform this command before designating the ports of the stack trunk with the STACKPORT command. Here is the command:

```
awplus(config)# stack enable
```

To disable the stacking function from a switch, use the NO STACK ENABLE command.

The format of the command, which is in the Global Configuration mode, is shown here:

```
no stack switch_ID enable
```

The variable is defined here:

- ❑ *switch_ID* - This is the ID number of a switch. The ID number is displayed on the ID LED on the chassis. It can also be viewed with the SHOW STACK command.

This example disables stacking on the switch with ID 2:

```
awplus(config)# no stack 2 enable
```

STACK PRIORITY

This command is used to assign priority numbers to switches. Switches use the numbers to select the master switch. The lower the number the higher the priority. The unit with the lowest number becomes the master. If switches have the same priority value, they use their MAC addresses to determine the master. As with priority numbers, the lower the MAC address, the higher the priority. A switch can have only one priority number.

Allied Telesis recommends making a switch's priority and ID numbers the same. This is not required, but it can make managing and troubleshooting a stack easier.

The command is in the Global Configuration mode of the command line interface. The format of the command is shown here:

```
stack switch_ID priority priority_number
```

The variables are defined here:

- ❑ *switch_ID* - This is the ID number of the switch. The range is 1 to 8. You can specify only one ID number.
- ❑ *priority_number* - This is the new priority number for the switch. You can specify only one number. The range is 0 to 255. The default is 128.

This example assigns the priority 1 to the switch with ID 1:

```
awplus(config)# stack 1 priority 1
```

This example assigns the priority 3 to the switch with ID 3:

```
awplus(config)# stack 3 priority 3
```

STACK RENUMBER

Every switch in a stack has to have a unique ID number assigned with this command. Here is the format.

```
stack current_switch_ID renumber new_switch_ID
```

The variables are defined here:

- ❑ *current_switch_ID* - This is the current ID number of the switch. You can specify only one ID number.
- ❑ *new_switch_ID* - This is the new ID number for the switch. You can specify only one number. The range is 1 to 8. The default is 1.

Changing the ID number requires resetting the switch.

This example changes the switch's ID from the default 1 to 2:

```
awplus(config)# stack 1 renumber 2
```

SWITCH PROVISION

To ensure that the first power-on of the stack is successful, Allied Telesis recommends configuring the units such that each unit knows about the others prior to forming the stack. This involves using the SWITCH PROVISION command to add switches as provisioned units on all the devices. Here is the format of the command:

```
switch switch_ID provision x950-28|x950-52
```

The variables are defined here:

- ❑ *x950-28* - Identifies the provisioned switch as an AT-x950-28XSQ or AT-x950-28XTQm Switch.
- ❑ *x950-52* - Identifies the provisioned switch as an AT-x950-52XSQ or AT-x950-52XTQm Switch.

This example adds a provisioned AT-x950-28XSQ or AT-x950-28XTQm Switch to the current switch and assigns it ID 2:

```
awplus(config)# switch 2 provision x950-28
```

This example adds a provisioned AT-x950-52XSQ or AT-x950-52XTQm Switch to the current switch and assigns it ID 3:

```
awplus(config)# switch 3 provision x950-52
```

Powering On a Switch

The following procedures in this section explain how to power on the switch:

- ❑ “Powering on PWR600 AC Power Supplies,” next
- ❑ “Powering on PWR600-80 DC Power Supplies” on page 204

If you have not installed the power supplies, refer to these procedures for instructions:

- ❑ “Installing AT-PWR600 and AT-PWR600R AC Power Supplies” on page 128
- ❑ “Installing AT-PWR600-80 and AT-PWR600R-80 DC Power Supplies” on page 132

Note

Before powering on the switch, review the information in “Power Specifications” on page 279.

Powering on PWR600 AC Power Supplies

This section contains the procedure for powering on the switch with AT-PWR600 or AT-PWR600R AC Power Supplies.



Warning

Power cord is used as a disconnection device. To de-energize equipment, disconnect the power cord. *ES* E3

Note

Pluggable Equipment. The socket outlet shall be installed near the equipment and shall be easily accessible. *ES* E5

To power on the switch, perform the following procedure

1. Connect the AC power cord included with the power supply to the AC power connector on the rear panel of the chassis. If the switch has two power supplies, you only need to power on one of them to configure the switch. Refer to Figure 123 on page 203.

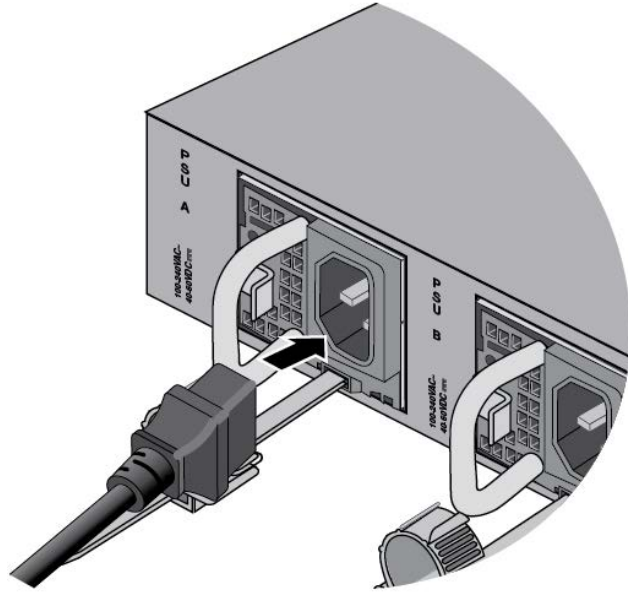
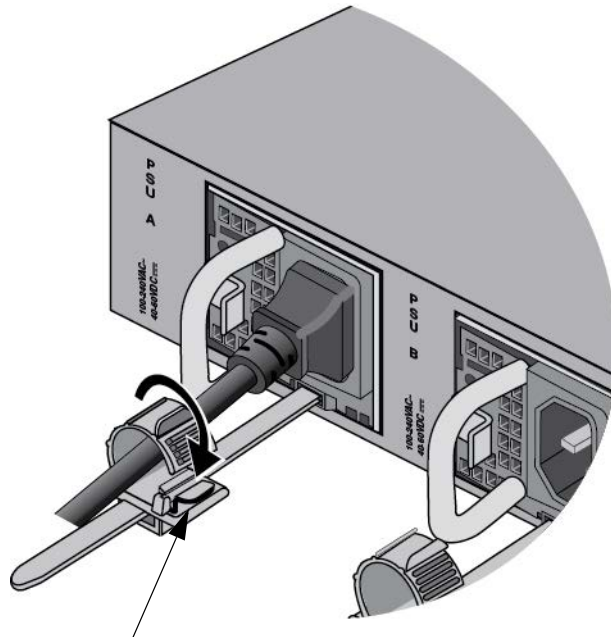

Figure 123. Connecting the AC Power Cord

2. Move the power cord into the restraining strap and secure the strap by feeding it into the tab slot. Refer to Figure 124.



Tab Slot

Figure 124. Securing the AC Power Cord with the Restraining Strap

3. Connect the power cord to an appropriate AC power source. Refer to Figure 125.

Note

The illustration shows the North American power cord. Your power cord may be different.

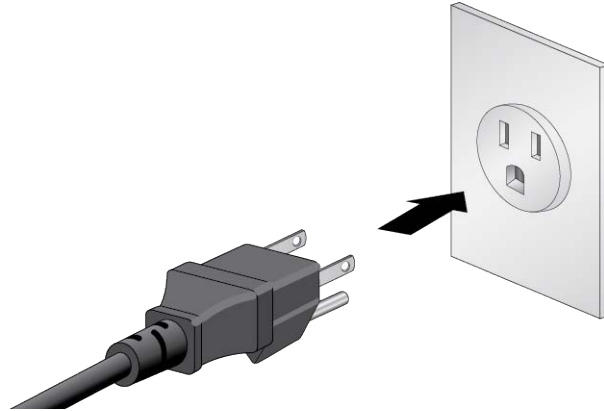

Figure 125. Connecting the Power Cord to an AC Power Source

Note

If the switch has two power supplies, you do not have to power on both of them to perform the procedures in this chapter.

4. If the switch has two AC power supplies, repeat this procedure to connect a power cord to the second power supply.
5. If the switch has a PWR600 DC Power Supply, go to “Powering on PWR600-80 DC Power Supplies,” next.
6. Wait several minutes for the switch to start the AlliedWare Plus management software.
7. Go to “Starting a Local Management Session” on page 206.

Powering on PWR600-80 DC Power Supplies

This procedure assumes that the AT-PWR600-80 or AT-PWR600R-80 DC Power Supplies are already installed in the switch and the terminals on the power supplies are wired. For instructions, refer to “Installing AT-PWR600-80 and AT-PWR600R-80 DC Power Supplies” on page 132.

To power on the switch with AT-PWR600-80 or AT-PWR600R-80 DC Power Supplies, perform the following procedure:

1. Verify that the DC power source that will provide power to the DC power supply is powered off. If the switch has two DC power supplies, verify that both DC power sources are powered off.

2. Verify that DC power wires are connected to the PWR600 DC Power Supply. For instructions, refer to “Installing AT-PWR600-80 and AT-PWR600R-80 DC Power Supplies” on page 132.
3. Connect the power wires to the DC power source. Refer to the documentation included with the DC power source for instructions.
4. Power on the DC power source. If the switch has two DC power supplies, power on both DC power sources.
5. If the switch also has a PWR600 AC Power Supply, go to “Powering on PWR600 AC Power Supplies” on page 202.
6. Wait several minutes for the switch to start the AlliedWare Plus management software.
7. Go to “Starting a Local Management Session” on page 206.

Starting a Local Management Session

This procedure explains how to start a local management session on the switch. It assumes that you powered on the device and waited several minutes for it to start the AlliedWare Plus management software.

Note

The first management session of the switch can be either a local session, as explained in this section, or a remote session over your network through the NET MGMT port. For remote management, the switch uses either its default IP address 192.168.42.42 or an address assigned to it by a DHCP server. For instructions on how to start a remote management session, refer to the *Software Reference for x950 Switches, AlliedWare Plus Operating System*.

To start a local management session, perform the following procedure:

1. Connect the RJ-45 end of the management card included with the switch to the Console RS-232 port on the management panel. Refer to Figure 126.

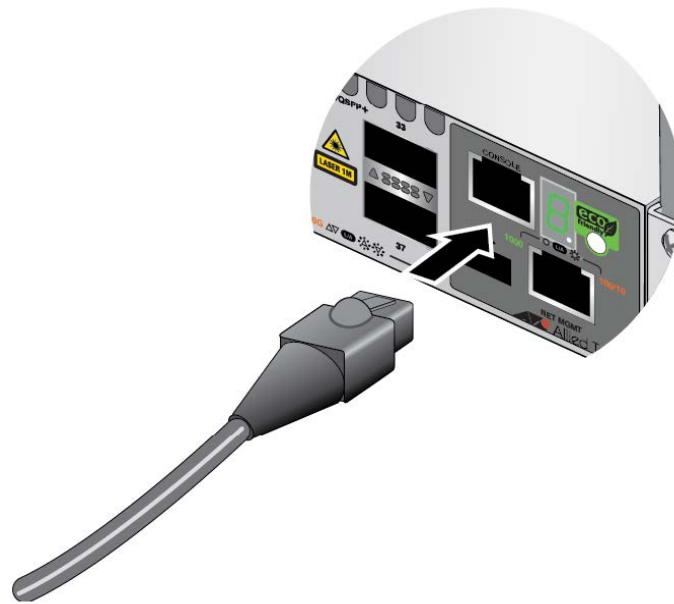

Figure 126. Connecting the Management Cable to the Console RS-232 Port

2. Connect the other end of the cable to an RS-232 port on a terminal or personal computer with a terminal emulation program.

3. Configure the VT-100 terminal or terminal emulation program as follows:

- Baud rate: 9600 bps
- Data bits: 8
- Parity: None
- Stop bits: 1
- Flow controller: None

Note

The port settings are for a DEC VT100 or ANSI terminal, or an equivalent terminal emulator program.

4. Press Enter. You are prompted for a user name and password.
5. Enter the default user name and password. They are “manager” and “friend” (without the quotes), respectively

Note

User names and passwords are case sensitive.

The local management session starts when the User Exec mode prompt, shown in Figure 127. is displayed.

A rounded rectangular box containing the text 'awplus>'.

Figure 127. User Exec Mode Prompt

Note

The User Exec mode is the first level in the command mode interface. For complete information on the modes and commands, refer to the *Software Reference for x950 Series Switches, AlliedWare Plus Operating System* from www.alliedtelesis.com.

6. Do one of the following:
 - To begin configuring the master switch, go to “Configuring the Master Switch - Part I” on page 210.
 - If you have already configured the master switch, go to Chapter 11, “Configuring Member Switches” on page 219.

General Steps for the Master Switch

The procedure for configuring the master switch is divided into two parts. Here are the general steps to “Configuring the Master Switch - Part I” on page 210.

Note

The procedures require resetting the switch. Some network traffic will be lost if the unit is already connected to an active network.

1. Start a local management session on the switch.
2. Verify the hardware with the `SHOW SYSTEM ENVIRONMENT` command in the Privilege Exec mode.
3. Display the firmware version number with the `SHOW VERSION` command.
4. Enable the VCStack feature with the `STACK ENABLE` command in the Global Configuration mode.
5. Assign the master switch the priority 1 with the `STACK PRIORITY` command in the Global Configuration mode. This is to ensure that it acts as the master switch during the first power-on of the stack.
6. Add the member switches as provisioned units to the master switch, with the `SWITCH PROVISION` command. This step ensures that the master switch knows about the member switches during the first power-on of the stack.
7. Save your changes with the `WRITE` command in the Privilege Exec mode.
8. Reboot the switch with the `REBOOT` command.

Here are the general steps to “Configuring the Master Switch - Part II” on page 213:

1. Start a new local management session.
2. Specify the types of transceivers to be used in the following 40G/100G ports on the master and provisioned member switches, with the `PLATFORM PORTMODE INTERFACE` command:
 - ❑ Ports 25, 29, 33, and 37 for the AT-x950-28XSQ and AT-x950-28XTQm Switches
 - ❑ Ports 49, 53, 57, 61 for the AT-x950-52XSQ and AT-x950-52XTQm Switches

Allied Telesis recommends performing this task at this point even if you are not using those ports for the stack trunk.

3. Designate the ports of the stack trunk on the master and provisioned member switches with the STACKPORT command in the port Interface mode.
4. Save your changes with the WRITE command in the Privilege Exec mode.
5. Reboot the switch with the REBOOT command.
6. Verify the changes with the SHOW STACK and SHOW RUNNING-CONFIG commands.

Configuring the Master Switch - Part I

This section contains Part I to configuring the master switch for stacking. In this procedure, you do the following:

- ❑ Verify the hardware status with the `SHOW SYSTEM ENVIRONMENT` command.
- ❑ Display the firmware version number with the `SHOW VERSION` command.
- ❑ Enable VCStack with the `STACK ENABLE` command.
- ❑ Assign the master switch the priority 1 with the `STACK PRIORITY` command in the Global Configuration mode.
- ❑ Add the member switches as provisioned switches with the `SWITCH PROVISION` command.
- ❑ Save the configuration and reboot the switch with the `WRITE` and `REBOOT` commands.

Allied Telesis recommends filling out the worksheet in “Stacking Worksheet” on page 104 before performing this procedure.

To configure the master switch, perform the procedure in Table 41.

Table 41. Configuring the Master Switch - Part I

Step	Description and Command
Steps 1 to 4 power on the switch, start a local management session, and verify the hardware operations of the unit.	
1	Power on the master switch and wait several minutes for it to start the AlliedWare Plus management software. Refer to “Powering On a Switch” on page 202.
2	Start a local management session. Refer to “Starting a Local Management Session” on page 206.
3	Move to the Privileged Exec mode with the <code>ENABLE</code> command. <code>awplus> enable</code>

Table 41. Configuring the Master Switch - Part I (Continued)

Step	Description and Command
4	<p>Verify that the switch hardware is operating correctly with the SHOW SYSTEM ENVIRONMENT command. The status of all components should be Ok.</p> <pre>awplus# show system environment Environment Monitoring Status Overall Status: Normal System Airflow: Front to back Resource ID: 1 Name: PSU Bay A (AT-PWR600) ID Sensor (Units) Reading Low Limit High Limit Status 1 Device Present Yes - - Ok 2 Fan/Temperature Fault Yes - - Ok . .</pre> <p>Note: If the System Airflow status is **INCOMPATIBLE**, the fans in the power supplies and fan modules have different airflow directions. Refer to “AT-PWR600 and AT-PWR600R AC and DC Power Supplies” on page 44 and “AT-FAN05 and AT-FAN05R Fan Modules” on page 52 for more information.</p>
<p>Step 5 displays the version number of the AlliedWare Plus management software on the switch. After viewing the version numbers on all the switches, you will compare them to confirm they all have the same version. Switches with different versions will have to be updated.</p>	
5	<p>Entering the SHOW VERSION command to display the version number of the AlliedWare Plus management software on the switch. Write down the version number in the worksheet in “Stacking Worksheet” on page 104 for the master switch.</p> <pre>awplus# show version</pre>
<p>Steps 6 to 8 activate VCStack and assign the switch the priority 1 so that it becomes the master switch when the stack is powered on.</p>	
6	<p>Move to the Global Configuration mode with the CONFIGURE TERMINAL command.</p> <pre>awplus# configure terminal Enter configuration commands, one per line. End with CNTL/Z.</pre>
7	<p>Activate VCStack on the switch with the STACK ENABLE command.</p> <pre>awplus(config)# stack enable % Automatically enabling 'stack virtual-mac' to minimize disruption form failovers. % Please check that the new MAC 0000.cd37.0431 is unique within the network. % Save the config and restart the system for this change to take effect.</pre>

Table 41. Configuring the Master Switch - Part I (Continued)

Step	Description and Command
8	<p>Assign priority 1 to the switch with the STACK PRIORITY command so that it becomes the master switch when the stack is powered-on.</p> <pre>awplus(config)# stack 1 priority 1 % warning: stacking is currently disabled.</pre>
<p>Step 9 adds the member switches as provisioned switches to the master switch. You need to add one provisioned switch for each member switch to be in the stack.</p>	
9	<p>Add the member switches as provisioned switches to the master switch, with the SWITCH PROVISION command. Assign them unique IDs in the range of 2 to 8. In this example, the stack will have three member switches. The member switch with ID 2 will be a 28-port x950 Switch. Those with IDs 3 and 4 will be 52-port switches.</p> <pre>awplus(config)# switch 2 provision x950-28 awplus(config)# switch 3 provision x950-52 awplus(config)# switch 4 provision x950-52</pre>
<p>Steps 10 to 15 save your changes and reboot the switch.</p>	
10	<p>Return to the Privileged Exec mode.</p> <pre>awplus(config)# exit</pre>
11	<p>Enter the WRITE command to save your change. If this is the first management session, the switch adds the configuration file DEFAULT.CFG to flash memory.</p> <pre>awplus# write Building configuration ... [OK]</pre>
12	<p>Restart the switch with the REBOOT command.</p> <pre>awplus# reboot reboot system? (y/n): awplus#</pre>
13	<p>Type “Y” for yes.</p>
14	<p>Wait several minutes for the switch to start the AlliedWare Plus management software.</p>
15	<p>Check the ID LED in the management panel on the front panel and do one of the following:</p> <ul style="list-style-type: none"> - If the ID LED is displaying the number 1, VCStack is now enabled on the switch. Go to “Configuring the Master Switch - Part II” on page 213. - If the ID LED is displaying “0,” VCStack is still disabled. Repeat this procedure. Be sure to issue the WRITE command to save your change before resetting the switch.

Configuring the Master Switch - Part II

In this procedure, you designate the types of transceivers to be used in these 40G/100G transceiver ports on the master and provisioned member switches:

- ❑ Ports 25, 29, 33, and 37 on AT-x950-28XSQ and AT-x950-28XTQm Switches
- ❑ Ports 49, 53, 57, 61 on AT-x950-52XSQ and AT-x950-52XTQm Switches
- ❑ Ports 1, 5, 9, and 13 on AT-XEM2-4QS Line Cards

The ports support 40G QSFP+ and 100G QSFP28 transceivers, and 4x10G breakout cables. The default is 40G QSFP+ transceivers. For more information, refer to “Ports for 40G QSFP+ and 100G QSFP28 Transceivers, and Breakout Cables” on page 30 and “PLATFORM PORTMODE INTERFACE” on page 198.

This procedure also designates the trunk ports.

To add the provisioned member switches to the master switch, perform the procedure in Table 42.

Table 42. Configuring the Master Switch - Part II

Step	Description and Command
1	Start a new local management session. Refer to “Starting a Local Management Session” on page 206.
2	Move to the Privileged Exec mode with the ENABLE command. awplus> enable
3	Move to the Global Configuration mode with the CONFIGURE TERMINAL command. awplus# configure terminal Enter configuration commands, one per line. End with CNTL/Z.
Steps 4 identifies the types of transceivers to be used in the 40G/100G ports on the master switch.	
4	Enter the PLATFORM PORTMODE INTERFACE command in the Global Configuration mode to designate the types of transceivers for the 40G/100G ports on the master switch. This example assumes the master switch is a 28-port x950 Switch. The command configures ports 33 and 37 for 100G transceivers: awplus(config)# platform portmode interface port1.0.33-1.0.37 100g
Steps 5 to 7 designate the stack ports on the master switch with the STACKPORT command.	

Table 42. Configuring the Master Switch - Part II (Continued)

Step	Description and Command
5	<p>Enter the port Interface modes of the ports that will be the stack trunk on the master switch. In this example, the master switch is a 28-port x950 Switch. It will use ports 33 and 37 as the stack trunk:</p> <pre>awplus(config)# interface port1.0.33-1.0.37</pre>
6	<p>Designate the ports as trunk ports with the STACKPORT command.</p> <pre>awplus(config-if)# stackport</pre> <p>% Save the config and restart the system for this change to take effect.</p>
7	<p>Return to the Global Configuration mode.</p> <pre>awplus(config-if)# exit</pre>
<p>Steps 8 uses the PLATFORM PORTMODE INTERFACE command to designate the types of transceivers for the 40G/100G ports in the provisioned member switches on the master switch. For more information, refer to “Ports for 40G QSFP+ and 100G QSFP28 Transceivers, and Breakout Cables” on page 30 and “PLATFORM PORTMODE INTERFACE” on page 198.</p>	
8	<p>In this example, the provisioned member switch with ID 2 is a 28-port x950 Switch. It will use 100G transceivers in ports 32 and 37. Provisioned member switches with IDs 3 and 4 are 52-port x950 Switches. They will also use 100G transceivers in ports 57 and 61:</p> <pre>awplus(config)# platform portmode interface port2.0.33-2.0.37 100g awplus(config)# platform portmode interface port3.0.57-3.0.61 100g awplus(config)# platform portmode interface port4.0.57-4.0.61 100g</pre>
<p>Steps 9 and 10 use the STACKPORT command in the port interface modes to designate the stack ports in the provisioned switches on the master switch.</p>	
9	<p>This example enters the port interface modes on the same switches and ports as in step 8. It assumes the member switches will use those ports as the stack trunk:</p> <pre>awplus(config)# interface port2.0.33-2.0.37,port3.0.57-3.0.61, port4.0.57-4.0.61</pre>
10	<p>Designate the ports as trunk ports with the STACKPORT command.</p> <pre>awplus(config-if)# stackport</pre> <p>% Save the config and restart the system for this change to take effect.</p>
<p>Steps 11 to 17 save your changes and reboot the switch.</p>	
11	<p>Return to the Global Configuration mode.</p> <pre>awplus(config-if)# exit</pre>

Table 42. Configuring the Master Switch - Part II (Continued)

Step	Description and Command
12	Return to the Privileged Exec mode. awplus(config)# exit
13	Enter the WRITE command to save your change. awplus# write Building configuration ... [OK]
14	Restart the switch with the REBOOT command. awplus# reboot reboot system? (y/n): awplus#
15	Type "Y" for yes.
16	Wait several minutes for the switch to start the AlliedWare Plus management software.
17	Go to "Verifying the Master Switch" on page 216.

Table 43. Verifying the Master Switch (Continued)

Step	Description and Command
5	<p>Enter the SHOW RUNNING-CONFIG command to verify the following:</p> <ul style="list-style-type: none"> - Check the running configuration for SWITCH PROVISION commands. There should be one command for each switch. The commands should designate x950 Switches. Here are examples: <pre>switch 1 provision x950-28 switch 2 provision x950-28 switch 3 provision x950-52 switch 4 provision x950-52</pre> <ul style="list-style-type: none"> - Check the running configuration for STACKPORT commands. The commands should designate the trunk ports for each switch. Here are examples: <pre>. interface port1.0.33-1.0.37 stackport . interface port2.0.33-2.0.37 stackport . interface port3.0.57-3.0.61 stackport . interface port4.0.57-4.0.61 stackport</pre>
6	Go to “What to Do Next” on page 218.

What to Do Next

After configuring the master switch, do the following:

1. Power off the switch by performing the following:
 - ❑ For the AT-PWR600-80 or AT-PWR600R-80 DC Power Supply, power off the DC power source.
 - ❑ For the AT-PWR600 or AT-PWR600R AC Power Supply, disconnect the AC power cords from the AC power sources. Refer to Figure 128.

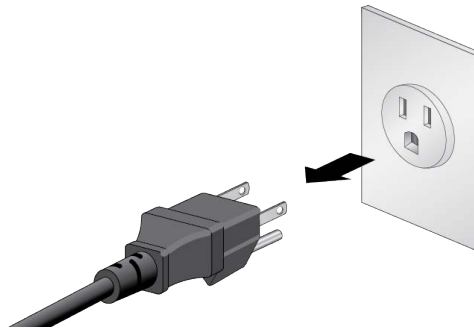

Figure 128. Powering Off the AT-PWR600 or AT-PWR600R AC Power Supply

2. Configure the member switches, as explained in Chapter 11, “Configuring Member Switches” on page 219.
3. After configuring the master and member switches, verify that all the units are powered off.
4. Cable the ports of the stack trunk. Refer to Chapter 13, “Cabling the Networking Ports” on page 235.
5. Power on the switches of the stack. Refer to “Powering on the Stack” on page 232.
6. Verify that the switches formed the stack. Refer to “Verifying the Stack” on page 233.
7. Cable the networking ports. Refer to Chapter 13, “Cabling the Networking Ports” on page 235.

Chapter 11

Configuring Member Switches

This chapter contains the following sections:

- ❑ “General Steps for Member Switches” on page 220
- ❑ “Configuring a Member Switch - Part I” on page 222
- ❑ “Configuring a Member Switch - Part II” on page 225
- ❑ “Verifying a Member Switch” on page 227
- ❑ “What to Do Next” on page 229

General Steps for Member Switches

The procedure for configuring a member switch has two parts:

- ❑ “Configuring a Member Switch - Part I” on page 222
- ❑ “Configuring a Member Switch - Part II” on page 225

Note

The procedures require resetting a member switch twice. Network traffic will be lost if the switch is already connected to an active network.

Here are the general steps to Part I:

1. Start a local management session on a member switch.
2. Verify the hardware with the `SHOW SYSTEM ENVIRONMENT` command in the Privilege Exec mode.
3. Enable the VCStack feature with the `STACK ENABLE` command in the Global Configuration mode.
4. Assign the member switch a unique ID number in the range of 2 to 8 with the `STACK RENUMBER` command in the Global Configuration mode.
5. If the stack will have three or more switches, use the `SWITCH PROVISION` command to add the other member switches as provisioned switches to the member switch.
6. Save your changes with the `WRITE` command in the Privilege Exec mode.
7. Restart the switch with the `REBOOT` command.

Here are the general steps to “Configuring a Member Switch - Part II” on page 225:

1. Start a new local management session.
2. Change the switch’s priority number to match its ID number with the `STACK PRIORITY` command in the Global Configuration mode.
3. Specify the types of transceivers to be used in the 40G/100G ports on the member switch and provisioned switches with the `PLATFORM PORTMODE INTERFACE` command.

4. Designate the ports of the stack trunk on the member switch and provisioned switches with the STACKPORT command in the port Interface mode.
5. Save your changes with the WRITE command in the Privilege Exec mode.
6. Restart the switch with the REBOOT command.
7. Start a new local management session.
8. Verify the changes with the SHOW STACK and SHOW RUNNING-CONFIG commands.

Configuring a Member Switch - Part I

The instructions for configuring a member switch are divided into two parts. In Part I you do the following:

- ❑ Display the hardware status with the SHOW SYSTEM ENVIRONMENT command.
- ❑ Display the firmware version number with the SHOW VERSION command.
- ❑ Enable VCStack with the STACK ENABLE command.
- ❑ Set the switch ID number with the STACK RENUMBER command.
- ❑ Add the other member switches as provisioned members with the SWITCH PROVISION command.
- ❑ Save the configuration and reboot the switch with the WRITE and REBOOT commands.

Allied Telesis recommends filling out the worksheet in “Stacking Worksheet” on page 104 before performing the procedures. To configure a member switch, perform the procedure in Table 44.

Table 44. Configuring a Member Switch - Part I

Step	Description and Command
1	Power on the member switch and wait several minutes for it to start the AlliedWare Plus management software. Refer to “Powering On a Switch” on page 202.
2	Start a local management session. Refer to “Starting a Local Management Session” on page 206.
3	Enter the ENABLE command to move from the User Exec mode to the Privileged Exec mode. awplus> enable
4	Verify the status of the switch hardware with the SHOW SYSTEM ENVIRONMENT command. All components should have a status of Ok. awplus# show system environment Environment Monitoring Status Overall Status: Normal System Airflow: Front to back Resource ID: 1 Name: PSU Bay A (AT-PWR600) ID Sensor (Units) Reading Low Limit High Limit Status 1 Device Present Yes - - ok 2 Fan/Temperature Fault Yes - - ok .

Table 44. Configuring a Member Switch - Part I (Continued)

Step	Description and Command
	<p>Note: If the System Airflow status is **INCOMPATIBLE**, the fans in the power supplies and fan modules have different airflow directions. Refer to “AT-PWR600 and AT-PWR600R AC and DC Power Supplies” on page 44 and “AT-FAN05 and AT-FAN05R Fan Modules” on page 52 for more information.</p>
5	<p>Enter the SHOW VERSION command to display the version number of the AlliedWare Plus management software on the switch. Write down the version number in the worksheet in “Stacking Worksheet” on page 104. After viewing the version numbers on all the switches, you should compare them to confirm they all have the same version. Switches with different versions will need to be updated.</p> <pre>awplus# show version</pre>
6	<p>Move to the Global Configuration mode with the CONFIGURE TERMINAL command.</p> <pre>awplus# configure terminal</pre> <p>Enter configuration commands, one per line. End with CNTL/Z.</p>
7	<p>Activate VCStack on the member switch with the STACK ENABLE command.</p> <pre>awplus(config)# stack enable</pre> <p>% Automatically enabling 'stack virtual-mac' to minimize disruption from failovers. % Please check that the new MAC 0000.cd37.0431 is unique within the network. % Save the config and restart the system for this change to take effect.</p>
8	<p>Assign a unique ID number in the range of 2 to 8 to the member switch with the STACK RENUMBER command. This example assigns the ID number 2 to the switch.</p> <pre>awplus(config)# stack 1 renumber 2</pre> <p>% Warning: Stacking is currently disabled. % Warning: the new ID will not become effective until the stack-member reboots. % Warning: the boot configuration may now be invalid.</p>
9	<p>If the stack will have other member switches, add them as provisioned switches with the SWITCH PROVISION command. Assign them their unique IDs in the range of 2 to 8. This example adds two provisioned x950 Switches, one a 28-port switch and the other a 52-port switch, with the IDs 3 and 4:</p> <pre>awplus(config)# switch 3 provision x950-28 awplus(config)# switch 4 provision x950-52</pre>
10	<p>Return to the Privileged Exec mode.</p> <pre>awplus(config)# exit</pre>

Table 44. Configuring a Member Switch - Part I (Continued)

Step	Description and Command
11	<p>Enter the WRITE command to save your changes. If this is the first management session, the switch adds the configuration file DEFAULT.CFG to flash memory for storing your configuration changes.</p> <pre>awplus# write Building configuration ... [OK]</pre>
12	<p>Restart the switch with the REBOOT command.</p> <pre>awplus# reboot reboot system? (y/n): awplus#</pre>
13	Type "Y" for yes.
14	Wait several minutes for the switch to start the AlliedWare Plus management software.
15	<p>Check the ID LED on the front panel and do one of the following:</p> <ul style="list-style-type: none"> - If the ID LED is displaying the ID number you assigned the switch, VCStack is now enabled on the switch. Go to "Configuring a Member Switch - Part II" on page 225. - If the ID LED is displaying the wrong ID number for the switch, repeat the STACK RENUMBER command in the Global Configuration mode. - If the ID LED is displaying "0," VCStack is still disabled. Repeat the STACK ENABLE command, also in the Global Configuration mode. - Remember to save your changes with the WRITE command.

Configuring a Member Switch - Part II

This section contains the second part to configuring member switches. The steps show how to configure the following parameters:

- ❑ Set the priority number of the member switch to match its ID number with the STACK PRIORITY command.
- ❑ Specify the types of transceivers to be used in the 40G/100G ports on the member switch and provisioned switches with the PLATFORM PORTMODE INTERFACE command.
- ❑ Designate the ports of the stack trunk with the STACKPORT command. Refer to “Stack Trunks” on page 84.

Perform the Part II procedure in Table 45 to configure a member switch.

Table 45. Configuring a Member Switch - Part II

Step	Description and Command
1	Start a new local management session on the member switch. Refer to “Starting a Local Management Session” on page 206.
2	Enter the ENABLE command to move from the User Exec mode to the Privileged Exec mode. awplus> enable
3	Move to the Global Configuration mode with the CONFIGURE TERMINAL command. awplus# configure terminal Enter configuration commands, one per line. End with CNTL/Z.
4	Change the switch’s priority to match its ID number with the STACK PRIORITY command. This example sets priority to 2 on a member switch with the ID 2: awplus(config)# stack 2 priority 2
5	Enter the PLATFORM PORTMODE INTERFACE command to specify the types of transceivers to be used in the 40G/100G ports on the member switch and the provisioned switches. This example assumes the stack will have four switches. Switches with ID numbers 1 and 2 are 28-port x950 Switches. Switches with ID numbers 3 and 4 are 52-port switches. The commands configure the last two 40G/100G ports on all the switches for 100G transceivers. awplus(config)# platform portmode interface port1.0.33-1.0.37 100g awplus(config)# platform portmode interface port2.0.33-2.0.37 100g awplus(config)# platform portmode interface port3.0.57-3.0.61 100g awplus(config)# platform portmode interface port4.0.57-4.0.61 100g

Table 45. Configuring a Member Switch - Part II (Continued)

Step	Description and Command
6	<p>Enter the port Interface modes of the ports to be the stack trunk on the member switch and provisioned switches with the INTERFACE command. This example assumes the last two 40G/100G ports will be the stack trunk. As in step 5, switches with ID numbers 1 and 2 are 28-port x950 Switches while switches with ID numbers 3 and 4 are 52-port switches.</p> <pre>awplus(config)# interface port1.0.33-1.0.37,port2.0.33-2.0.37, port3.0.57-3.0.61,port4.0.57-4.0.61</pre>
7	<p>Designate the ports as the stack trunk with the STACKPORT command.</p> <pre>awplus(config-if)# stackport % Save the config and restart the system for this change to take effect.</pre>
8	<p>Return to the Global Configuration mode.</p> <pre>awplus(config-if)# exit</pre>
9	<p>Return to the Privileged Exec mode.</p> <pre>awplus(config)# exit</pre>
10	<p>Save your changes with the WRITE command.</p> <pre>awplus# write Building configuration ... [OK]</pre>
11	<p>Restart the switch.</p> <pre>awplus# reboot reboot system? (y/n):</pre>
12	<p>Type "Y" for yes.</p>
13	<p>Wait several minutes for the switch to start the AlliedWare Plus management software.</p>
14	<p>Go to "Verifying a Member Switch," next.</p>

Verifying a Member Switch

Perform the steps in Table 46 to confirm the configuration of a member switch.

Table 46. Verifying a Member Switch

Step	Description and Command
1	Start a local management session. Refer to “Starting a Local Management Session” on page 206.
2	Move to the Privileged Exec mode. awplus> enable
3	<p>Enter the SHOW STACK command. The example here is for a member switch with the ID 2, in a stack of four switches:</p> <pre>awplus# show stack Virtual Chassis Stacking summary information ID Pending ID MAC address Priority Status Role 1 - - - - Provisioned 2 - e01a.ba56.c112 2 Ready Active Master 3 - - - - Provisioned 4 - - - - Provisioned Operational Status Standalone unit Stack MAC address 0000.ab56.478c (Virtual MAC)</pre>
4	<p>Verify the display for the following:</p> <ul style="list-style-type: none"> - The table should have from two to eight entries, depending on the number of switches to be in the stack. - The entry with the Ready status and Active Master role is the switch you are currently managing. Its role will change to member after the stack is functioning. - Switch ID 1 will be for the master switch. - The other entries are for the member switches. There should be one entry for each member switch that will be in the stack. To add more entries, perform the SWITCH PROVISION command in “Configuring a Member Switch - Part I” on page 222. - The switch’s priority should match its ID number. If it does not, perform the STACK PRIORITY command in “Configuring a Member Switch - Part II” on page 225. - The Operational Status should be Standalone Unit. This indicates that stacking is enabled and the unit is operating as a stack of one switch. If the status is Stacking Hardware Disabled, the stacking feature is disabled. Perform the STACK ENABLE in “Configuring a Member Switch - Part I” on page 222. - Remember to save your changes with the WRITE command.

Table 46. Verifying a Member Switch (Continued)

Step	Description and Command
5	<p>Enter the SHOW RUNNING-CONFIG command and verify the following:</p> <ul style="list-style-type: none"> - Check the running configuration for SWITCH PROVISION commands. There should be one command for each switch. The commands should designate x950 Switches. Here is an example of a stack of four switches: <pre>switch 1 provision x950-28 switch 2 provision x950-28 switch 3 provision x950-52 switch 4 provision x950-52</pre> <ul style="list-style-type: none"> - Check the running configuration for STACKPORT commands. There should be one command for each switch. The commands should designate the trunk ports of the switches. In this example, two 28-port switches with ID numbers 1 and 2 will use ports 33 and 37 as the trunk ports. Two 52-port switches with ID numbers 3 and 4 will use ports 57 and 61. <pre>. interface port1.0.33-1.0.37 stackport . interface port2.0.33-2.0.37 stackport . interface port3.0.57-3.0.61 stackport . interface port4.0.57-4.0.61 stackport</pre>
6	Go to “What to Do Next,” next.

What to Do Next

After configuring a member switch, do the following:

1. Power off the switch by performing the following:
 - ❑ For PWR600 AC Power Supplies, disconnect the AC power cords from the AC power sources. Refer to Figure 128 on page 218.
 - ❑ For PWR600-80 DC Power Supplies, power off the DC power sources.
2. Repeat the procedures in this chapter to configure all member switches.
3. If you have not already configured the master switch, perform “Configuring the Master Switch - Part I” on page 210.
4. After configuring the master and member switches, verify that all the units are powered off.
5. Cable the stacking ports on the master and member switches. Refer to Chapter 13, “Cabling the Networking Ports” on page 235.
6. Power on the switches of the stack. Refer to “Powering on the Stack” on page 232.
7. Perform “Verifying the Stack” on page 233 to verify that the switches have successfully formed the stack.
8. Cable the networking ports, as explained in Chapter 13, “Cabling the Networking Ports” on page 235.

Chapter 12

Powering On and Verifying the Stack

This chapter contains the following sections:

- “Powering on the Stack” on page 232
- “Verifying the Stack” on page 233

Powering on the Stack

After configuring the master and member switches for stacking and cabling the trunk ports, you are ready to power on the stack for the first time. (If you want to monitor the power-on sequence, connect a terminal or PC with a terminal emulator program to the Console port on any of the switches).

To power on the stack for the first time, perform the following procedure:

1. Verify that all switches are powered off.
 - For PWR600 AC Power Supplies, disconnect the AC power cords from the AC power sources.
 - For PWR600-80 DC Power Supplies, power off the DC power sources.
2. If you have not yet cabled the trunk ports, do so now. Refer to Chapter 13, “Cabling the Networking Ports” on page 235.
3. Power on all the switches at the same time.
 - For PWR600 AC Power Supplies, refer to “Powering on PWR600 AC Power Supplies” on page 202.
 - For PWR600-80 DC Power Supplies, refer to “Powering on PWR600-80 DC Power Supplies” on page 204.

Refer to “Power Specifications” on page 279 for the power specifications of the switches.



Warning

Power cord is used as a disconnection device. To de-energize equipment, disconnect the power cord. *↪* E3

Note

Pluggable Equipment. The socket outlet shall be installed near the equipment and shall be easily accessible. *↪* E5

4. Wait several minutes for the switches to form the stack.
5. Go to “Verifying the Stack” on page 233.

Verifying the Stack

To verify the stack, perform the following procedure:

1. Start a local management session on any of the switches in the stack. Refer to “Starting a Local Management Session” on page 206.
2. From the User Exec mode, enter the SHOW STACK command:

```
awplus> show stack
```

An example of the command for a stack of four switches is shown in Figure 129.

```
awplus> show stack
Virtual Chassis Stacking summary information
ID      Pending ID      MAC address      Priority  Status  Role
1       -                e01a:ea20:8011  1        Ready  Active Master
2       -                e01a:ea20:ee45  2        Ready  Member
3       -                e01a:ea20:8a98  3        Ready  Member
4       -                e01a:ea20:1b67  4        Ready  Member
Operational Status      Normal operations
Stack MAC address       0015:774f:ed30
```

Figure 129. SHOW STACK Command

Review the following items:

- ❑ The command should list all the switches. If the list is incomplete, refer to Chapter 15, “Troubleshooting” on page 267.
 - ❑ The Operational Status field should be “Normal operations” to indicate that all the trunk ports are operating normally.
 - ❑ If the Operational Status field is displaying “Not all stack ports are up,” one or more trunk ports are not being used or cannot establish links with their counterparts. For more information, refer to Chapter 15, “Troubleshooting” on page 267.
3. Go to Chapter 13, “Cabling the Networking Ports” on page 235, to complete the installation.

Chapter 13

Cabling the Networking Ports

This chapter contains the following procedures:

- ❑ “Cabling Copper Ports” on page 236
- ❑ “Guidelines to Handling Copper or Fiber Optic Transceivers” on page 237
- ❑ “Installing Transceivers” on page 238
- ❑ “Installing Direct Attach Cables” on page 244

Cabling Copper Ports

This section applies to the copper ports on the following products:

- ❑ AT-x950-28XTQm Switch
- ❑ AT-x950-52XTQm Switch
- ❑ AT-XEM2-8XSTm Line Card
- ❑ XEM2-12XT Line Card
- ❑ XEM2-12XTm Line Card

Here are the cabling guidelines:

- ❑ Here are the minimum cable requirements:
 - 100M - Standard TIA/EIA 568-B-compliant Category 3 unshielded cabling.
 - 1G/2.5G/5G - Standard TIA/EIA 568-A-compliant Category 5 or TIA/EIA 568-B-compliant Enhanced Category 5 (Cat 5e) unshielded cabling.
 - 10G -Standard TIA/EIA 568-C-compliant Category 6a unshielded cabling.
- ❑ The connectors on the cables should fit snugly into the ports, and the tabs should lock the connectors into place.
- ❑ The default speed setting for the ports is Auto-Negotiation. This setting is appropriate for ports connected to network devices that also support Auto-Negotiation.
- ❑ The ports must be set to Auto-Negotiation, the default setting, to operate at 1G or higher speeds.
- ❑ The ports support full-duplex only.
- ❑ Do not attach cables to ports of static or LACP port trunks until after you have configured the ports on the switch. Otherwise, the ports will form network loops that can adversely affect network performance.

Guidelines to Handling Copper or Fiber Optic Transceivers

Please review the following guidelines before installing copper or fiber optic transceivers:

- ❑ Transceivers are hot-swappable. You can install them while the chassis is powered on.
- ❑ For a list of supported transceivers, refer to the product data sheet on the Allied Telesis web site.
- ❑ The operational specifications and fiber optic cable requirements are provided in the documents included with the transceivers.
- ❑ You should install transceivers in XEM2 Line Cards before connecting their fiber optic cables.
- ❑ Fiber optic transceivers are dust sensitive. Always keep the plug in the optical bores when a fiber optic cable is not installed, or when you store the transceiver. When you do remove the plug, keep it for future use.
- ❑ Repetitive removal or insertion of transceivers can lead to premature failures.
- ❑ 100G transceivers for XEM2-1CQ Line Cards have handles. Use the handles when installing or removing transceivers. An example is shown in Figure 130.

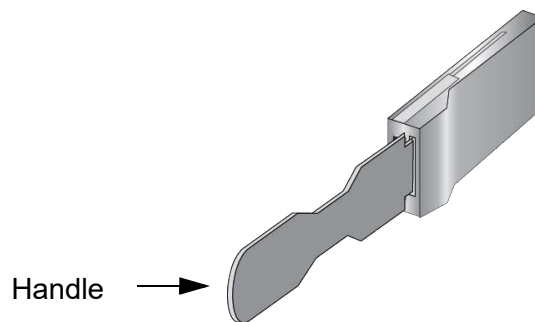

Figure 130. Handle on 100G Transceivers for XEM2-1CQ Line Cards



Caution

Transceivers can be damaged by static electricity. Be sure to observe all standard electrostatic discharge (ESD) precautions, such as wearing an antistatic wrist strap, to avoid damaging the devices. *ES* E92

Installing Transceivers

Table 47 lists the types of transceivers supported by the base transceiver slots. Refer to the product data sheet for a list of approved transceivers.

Table 47. Transceivers for the Base Transceiver Slots

Base Ports	Fiber Optic Transceiver
<p>Ports 1 to 24 on the AT-x950-28XSQ Switch</p> <p>Ports 1 to 48 on the AT-x950-52XSQ Switch</p>	<p>1G SFP or 10G SFP+ transceivers:</p> <ul style="list-style-type: none"> - 1G SX/LX SFP transceivers - 10G SR/LR SFP+ fiber optic transceivers - 1G/10G SP10T transceiver with RJ-45 connector - 10G SP10TW direct attach twinax cables with SFP+ transceiver-style connectors - 1G/2.5G/5G/10G SFP+ transceivers with an RJ-45 connector
<p>Ports 25, 29, 33, and 37 on the AT-x950-28XSQ and AT-x950-28XTQm Switches</p> <p>Ports 49, 53, 57, and 61 on the AT-x950-52XSQ and AT-x950-52XTQm Switches</p>	<p>100G QSFP28 transceivers:</p> <ul style="list-style-type: none"> - QSFP28SR4 transceiver - Maximum operating distance of 70m (230 ft) or 100m (328 ft) with 12-strand OM3 or OM4 fiber optic cable, respectively. Requires a MPO pluggable optical connector. - QSFP28LR4 transceiver - Operating range of 2m (6.6 ft) to 10km (6.2 mi). Requires single-mode fiber optic cable with a duplex LC connector. <p>40G QSFP+ transceivers, direct attach cables, and breakout cables:</p> <ul style="list-style-type: none"> - QSFPSR4 transceiver - requires 12-strand OM4 fiber optic cable and has a maximum operating distance of 150m (492 ft). - QSFPLR4 transceiver - requires single-mode fiber optic cable and has an operating range of 2 meters (6.6 ft) to 10km (6.2 mi).

Table 47. Transceivers for the Base Transceiver Slots (Continued)

Base Ports	Fiber Optic Transceiver
Base ports 25, 29, 33, and 37 on the AT-x950-28XSQ and AT-x950-28XTQm Switches Base ports 49, 53, 57, and 61 on the AT-x950-52XSQ and AT-x950-52XTQm Switches	- QSFP1CU and QSFP3CU direct attach cables in lengths of 1 and 3 meters, respectively. --QSFP-4SFP10G-3CU and QSFP-4SFP10G-5CU breakout cables in lengths of 3 and 5 meters, respectively.

SP10T transceivers with RJ-45 connections require that adjacent ports be left empty to prevent overheating. Refer to Figure 131.

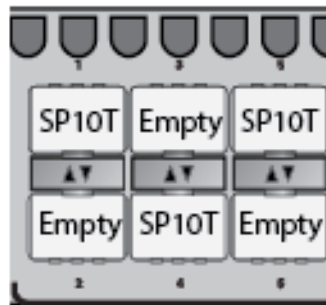

Figure 131. SP10T Transceivers

Table 48 lists the types of transceivers supported by the XEM2 Line Cards.

Table 48. Transceivers for XEM2 Ethernet Line Cards

Ethernet Line Card	Transceiver
AT-XEM2-8XSTm	1G SFP or 10G SFP+ transceivers: <ul style="list-style-type: none"> - 1G SX or LX SFP - 10G SR or LR SFP+ - 10G one meter SP10TW1, three meter SP10TW3, and seven meter SP10TW7 direct attach twinax cables, with SFP+ transceiver-style connectors

Table 48. Transceivers for XEM2 Ethernet Line Cards (Continued)

Ethernet Line Card	Transceiver
AT-XEM2-12XS	<p>1G SFP or 10G SFP+ transceivers:</p> <ul style="list-style-type: none"> - 1G SX or LX SFP fiber optic transceivers - 10G SR or LR SFP+ fiber optic transceivers - 10G one meter SP10TW1, three meter SP10TW3, and seven meter SP10TW7 direct attach twinax cables with SFP+ transceiver-style connectors (The XEM2-12XS v2 Card does not support the SP10TW7 cable.)
AT-XEM2-4QS	<p>40G QSFP+ transceivers:</p> <ul style="list-style-type: none"> - QSFPSR4 fiber optic transceiver - Maximum operating distance of 150 meters (492 feet) with 12-strand OM4 fiber optic cable. - QSFPLR4 fiber optic transceiver - Operating range of 2 meters (6.6 feet) to 10 kilometers (6.2 miles) with single-mode fiber optic cable. - QSFP1CU and QSFP3CU direct attach cables - Lengths of 1 and 3 meters, respectively.
XEM2-1CQ	<p>100G QSFP28 transceivers:</p> <ul style="list-style-type: none"> - QSFP28SR4 fiber optic transceiver - Maximum operating distance of 70m (230 ft) or 100m (328 ft) with 12-strand OM3 or OM4 fiber optic cable, respectively. Requires a MPO pluggable optical connector. - QSFP28LR4 fiber optic transceiver - Operating range of 2m (6.6 ft) to 10km (6.2 mi). Requires single-mode fiber optic cable with a duplex LC connector. - QSFP28-1CU and QSFP28-3CU direct attach cables in lengths of one and three meters, respectively.

Please review “Guidelines to Handling Copper or Fiber Optic Transceivers” on page 237 before performing the procedure.

Your transceivers may look different than those shown in the following illustrations.



Warning

The temperature of an operational transceiver can exceed 70° C (158° F). Exercise caution when removing or handling transceivers with unprotected hands. E43

To install a fiber optic transceiver, perform the following procedure:

1. Select a port for the transceiver.
2. If the selected port has a dust cover, remove it.
3. Remove the transceiver from its shipping container and store the packaging material in a safe location.
4. Orient the transceiver and slide it into the port until it clicks into place. The correct orientation depends on the line card and transceiver:
 - ❑ Base ports 1 to 24 and AT-XEM2-8XSTm and AT-XEM2-12XS Line Cards - To install a transceiver in an odd numbered port, position it with its handle on top. To install a transceiver in an even numbered port, position it with its handle on the bottom. Refer to Figure 132 on page 241.

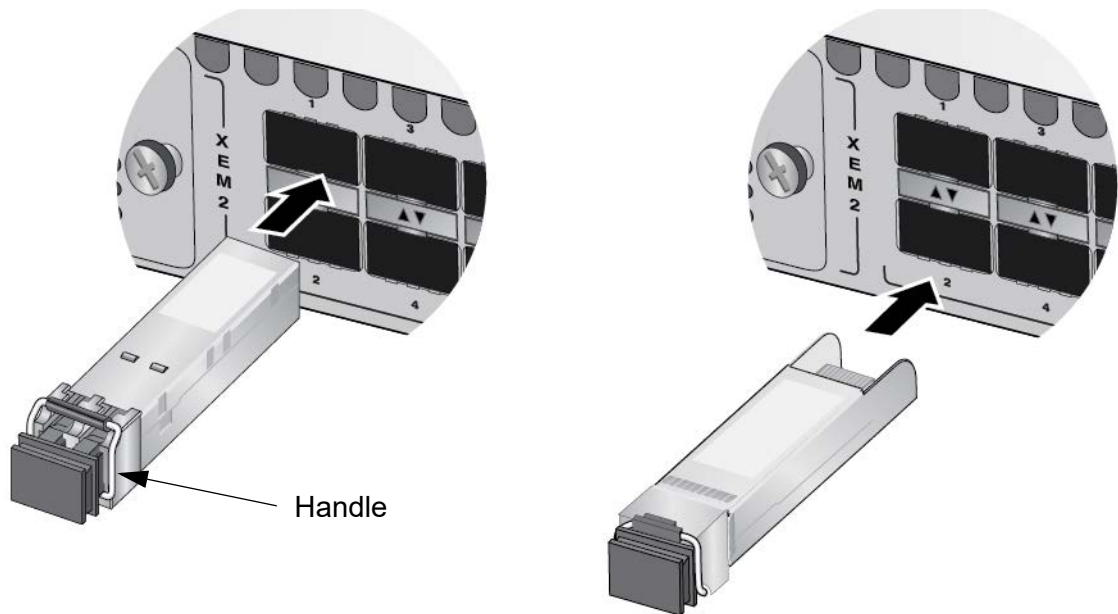

Figure 132. Installing an SFP or SFP+ Transceiver

- ❑ 40G transceivers in AT-XEM2-4QS Line Cards - refer to Figure 133.

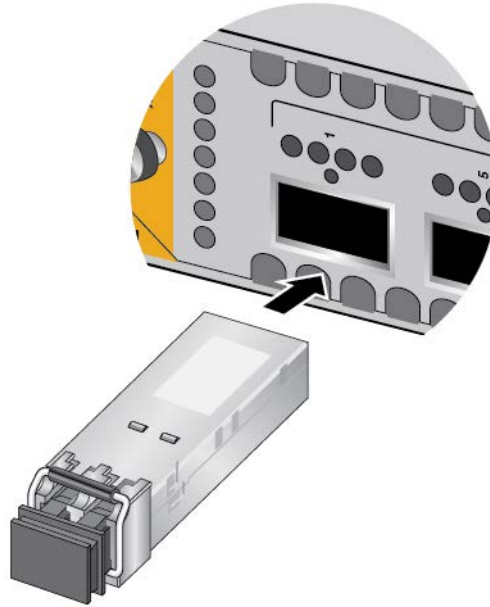

Figure 133. Installing 40G Fiber Optic Transceivers in AT-XEM2-4QS Line Cards

- ❑ 100G QSFP28 transceivers for ports 25 to 37: refer to Figure 134.

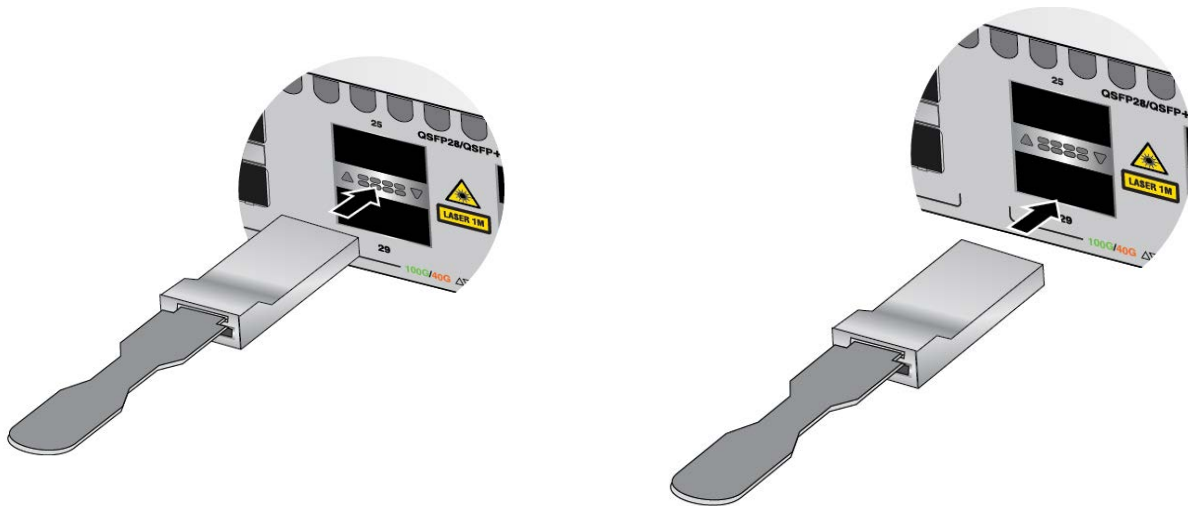

Figure 134. Installing 100G QSFP28 Transceivers in Base Ports 25, 29, 33, 37

- ❑ 100G QSFP28 transceivers for XEM2-1CQ Line Card: refer to Figure 135.

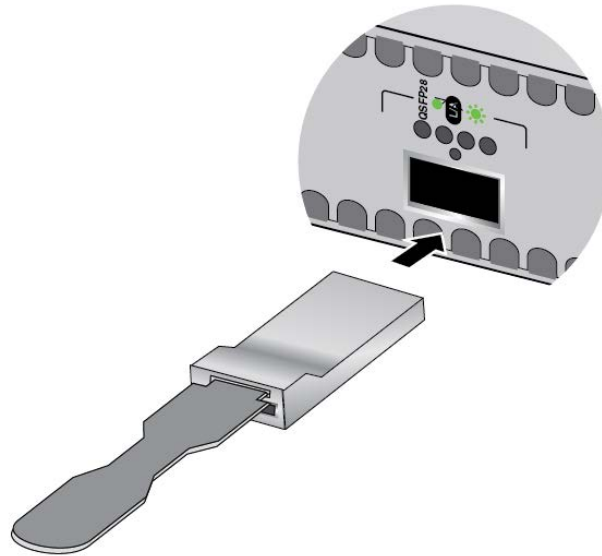

Figure 135. Installing 100G QSFP28 Transceivers in XEM2-1CQ Line Cards

Note

If you are ready to attach the fiber optic cable to the transceiver, continue with the next step. Otherwise, repeat steps 1 to 4 to install additional transceivers.

5. If the fiber optic connector on the transceiver has a dust cover, remove the cover.
6. Connect the fiber optic cable to the connector on the transceiver. The cable is keyed such that it can connect to the transceiver only one way.
7. Repeat this procedure to install additional transceivers.

Installing Direct Attach Cables

Table 12 on page 43 lists the direct attach cables for the base ports and XEM2 Line Cards. They offer an economical way to add 10G, 40G, or 100G connections over short distances. To install direct attach cables, perform the following procedure:

1. Select a port for the direct attach cable.
2. If the selected port has a dust cover, remove the cover.
3. Remove the transceiver from its shipping container and store the packaging material in a safe location.
4. Orient the transceiver and slide it into the port until it clicks into place. The correct orientation depends on the cable:
 - Figure 136 shows the orientations for SP10TW direct attach cables installed in base ports 1 to 24 and AT-XEM2-8XSTm and AT-XEM2-12XS Cards.



Figure 136. Installing SP10TW Direct Attach Cables

- Figure 137 on page 245 shows the orientations for QSFP4C Cables installed in base ports 25 to 37.



Figure 137. Attaching QSFP28/QSFP+ Cables

5. Connect the other end of the cable into a compatible port on another network device.
6. Repeat this procedure to install additional direct attach cables.

Note

To remove a cable from the port, gently push on the connector, pull on the release tab, and slide the connector from the port.

Chapter 14

Replacing Modules

This chapter contains the following procedures:

- ❑ “Replacing XEM2 Line Cards” on page 248
- ❑ “Replacing PWR600 and AT-PWR600R AC Power Supplies” on page 253
- ❑ “Replacing AT-PWR600-80 and AT-PWR600R-80 DC Power Supplies” on page 258
- ❑ “Replacing FAN05 Modules” on page 261

Replacing XEM2 Line Cards

This section contains the procedure for replacing XEM2 Line Cards in x950 Switches. The illustrations in the procedure show the AT-XEM2-12XT line card. The procedure is the same for all cards. Please review the following guidelines before performing the procedure:

- ❑ All XEM2 Line Cards are hot-swappable. You do not have to power off or reboot the switch when installing or replacing a line card.
- ❑ When powered on, an XEM2 Line Card might require up to thirty seconds to initialize its management software and begin forwarding network traffic.

Note

Allied Telesis recommends saving a backup copy of the configuration file in the switch before removing or replacing line cards. For instructions, refer to the Software Reference for x950 Switches.

Note

The XEM2 Line Cards are also used in the SBx908 GEN2 Switch. Please note that you have to reboot that switch when hotswapping the AT-XEM2-1CQ Line Card.

This procedure requires a #2 Phillips-head screwdriver (not provided).

To remove an XEM2 Line Card from the switch, perform the following procedure:

1. Label and remove all cables from the line card.
2. If the line card has fiber optic transceivers, install dust covers on the ports.
3. If the line card has transceivers or direct attach cables, label and remove the transceivers or cables.



Warning

The temperature of an operational transceiver may exceed 70° C (158° F). Exercise caution when removing or handling transceivers with unprotected hands. *↪* E43

Note

100G transceivers for the AT-XEM2-1CQ Line Card have handles. Always use the handles when installing or removing transceivers.

4. Use a #2 Phillips-head screwdriver to loosen the two screws on the faceplate of the card. Refer to Figure 138.

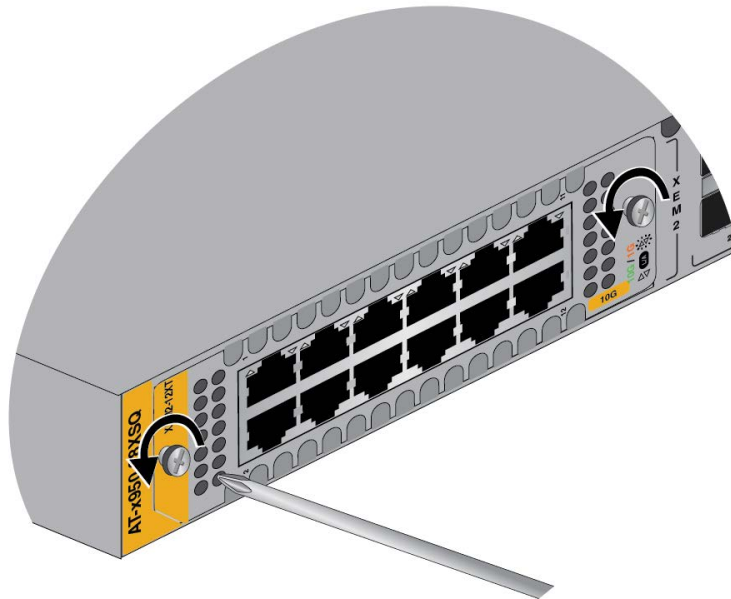

Figure 138. Loosening the Screws on the Ethernet Line Card

5. Carefully pull on the screws on the faceplate to disconnect the line card from the internal connector in the switch. Refer to Figure 139 on page 250.

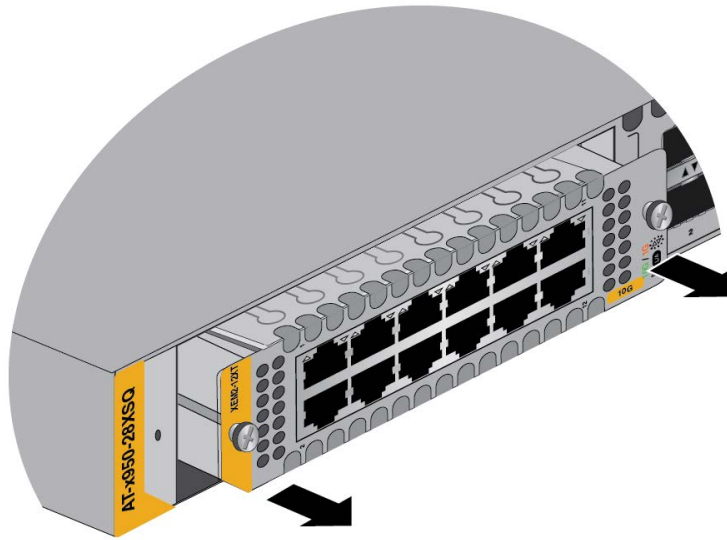

Figure 139. Disconnecting the XEM2 Line Card from the Switch

6. Carefully slide the card from the switch. Refer to Figure 140.

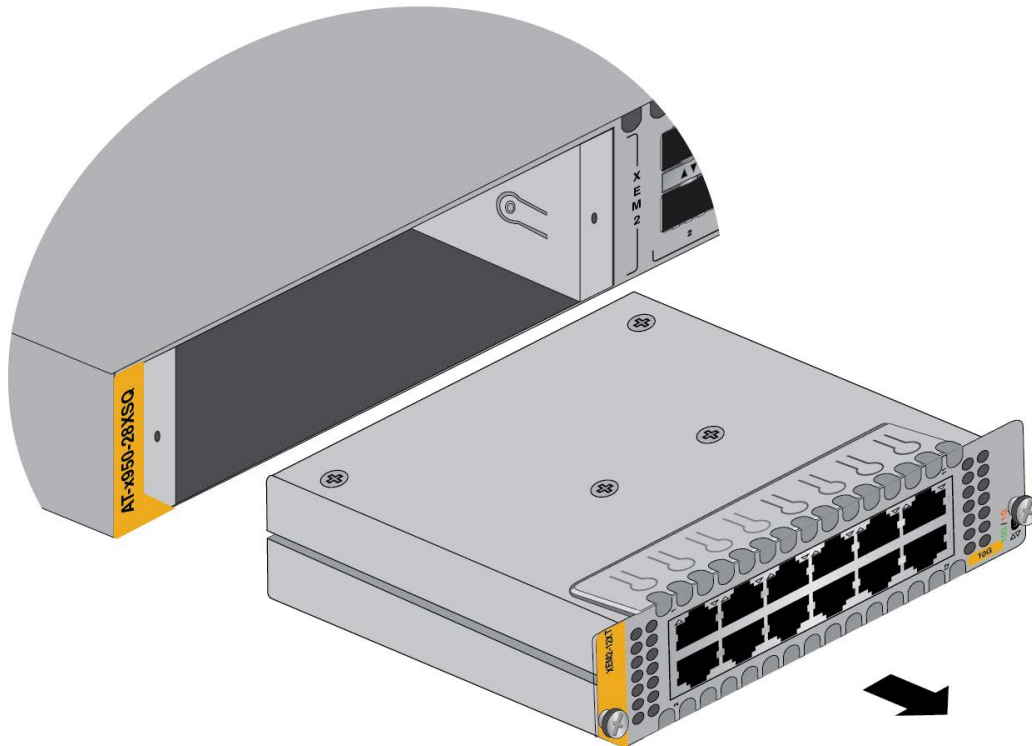

Figure 140. Sliding the XEM2 Line Card from the Switch

7. If you are not installing the line card in another switch, store it in its anti-static bag and shipping container. Refer to Figure 141.



Figure 141. Placing the XEM2 Line Card in its Anti-static Bag

8. Do one of the following:
- For instructions on how to install another card in the slot, start with step 2 in “Installing XEM2 Ethernet Line Cards” on page 141.
 - If you are not installing another line card in the slot now, continue with the next step to install the blank cover.
9. Orient the blank cover as shown in Figure 142, with the notch on the bottom left, and slid it into the slot.

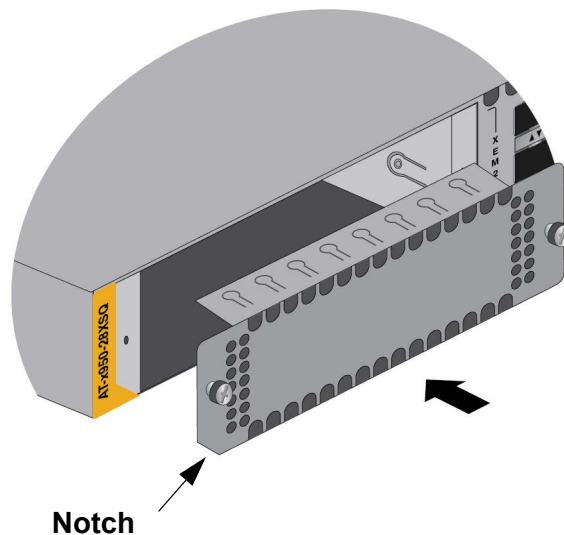

Figure 142. Installing the Line Card Blank Cover

10. Tighten the two screws to secure it to the switch. Refer to Figure 143.

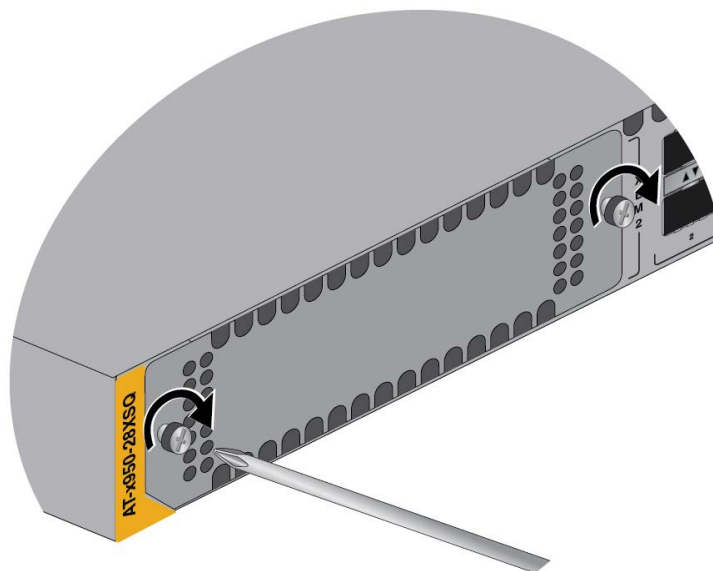

Figure 143. Tightening the Two Screws on the Line Card Blank Panel

Replacing PWR600 and AT-PWR600R AC Power Supplies

This section contains the procedure for removing or replacing AT-PWR600 and AT-PWR600R AC Power Supplies. The following illustrations show the removal of a power supply from slot PSU A. The procedure is the same for slot PSU B.

Note

Allied Telesis recommends saving a backup copy of the configuration file in the switch before removing or replacing power supplies. For instructions, refer to the Software Reference for x950 Switches.

To remove power supplies from the switch, perform the following procedure:

1. Disconnect the AC power cord for the power supply from the AC power source. Refer to Figure 144.

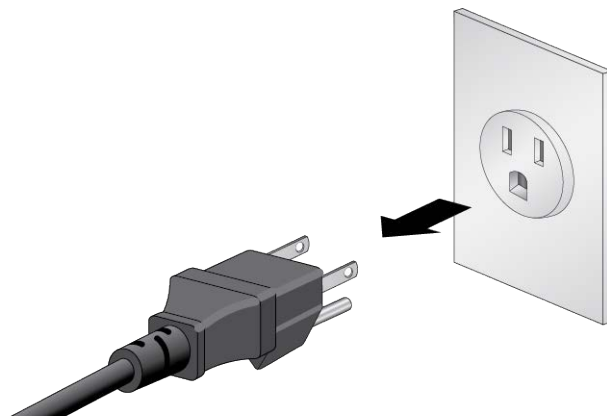

Figure 144. Disconnecting the AC Power Cord from the Power Source

2. Open the restraining strap on the power cord by pressing down on the release tab and pulling out the strap. Refer to Figure 145 on page 254.

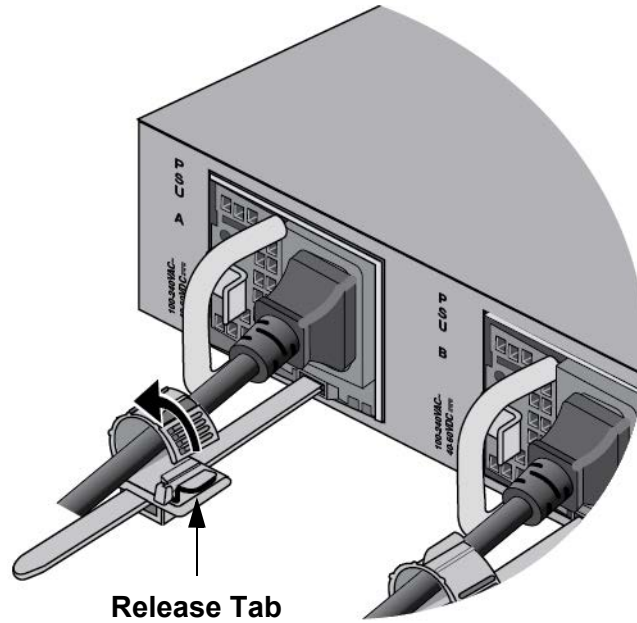

Figure 145. Opening the Restraining Strap on the PWR600 Power Supply

3. Disconnect the power cord from the power supply. Refer to Figure 146.

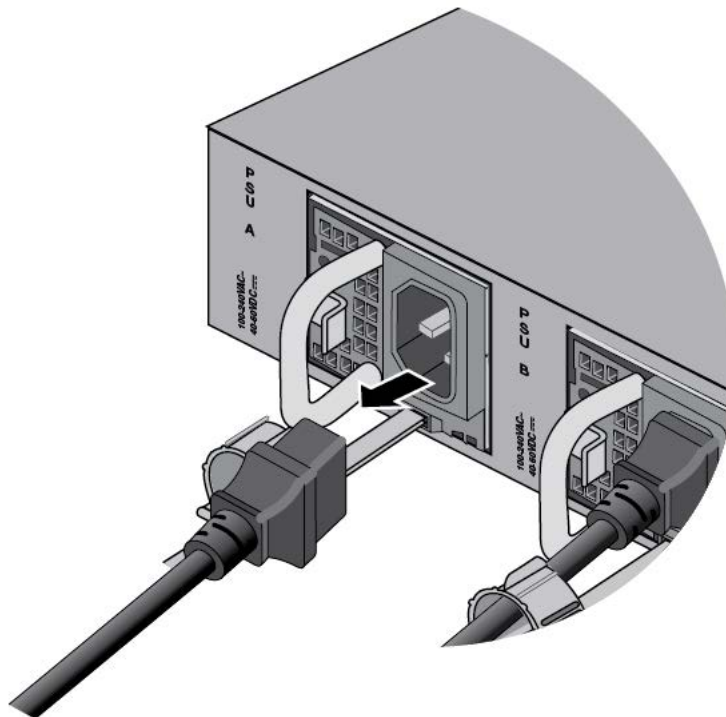

Figure 146. Disconnecting the Power Cord from the PWR600 Power Supply

4. Press the release lever to the right and pull on the handle to release the power supply from the internal connector in the switch. Refer to Figure 147.

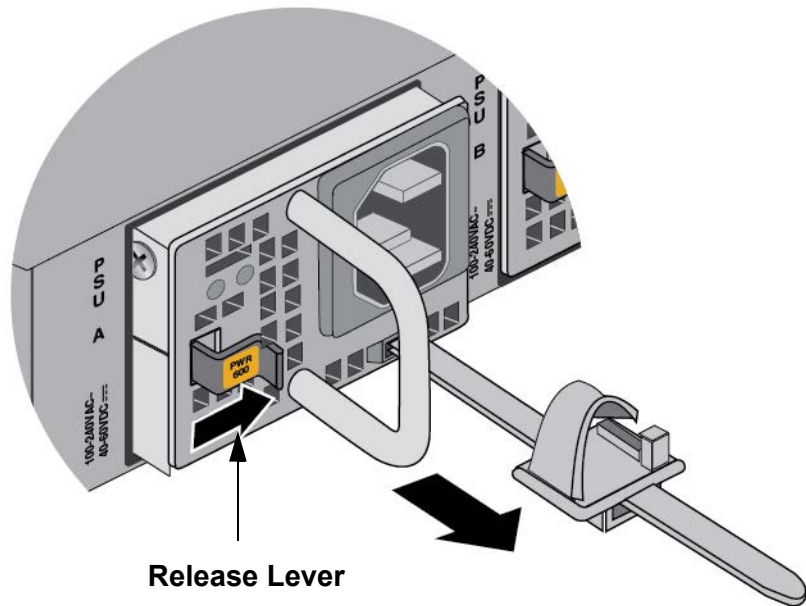

Figure 147. Removing the PWR600 Power Supply

5. Carefully slide the power supply from the switch. Refer to Figure 148 on page 256.



Caution

The device is heavy. Use both hands to lift it. You might injure yourself or damage the device if you drop it. E94

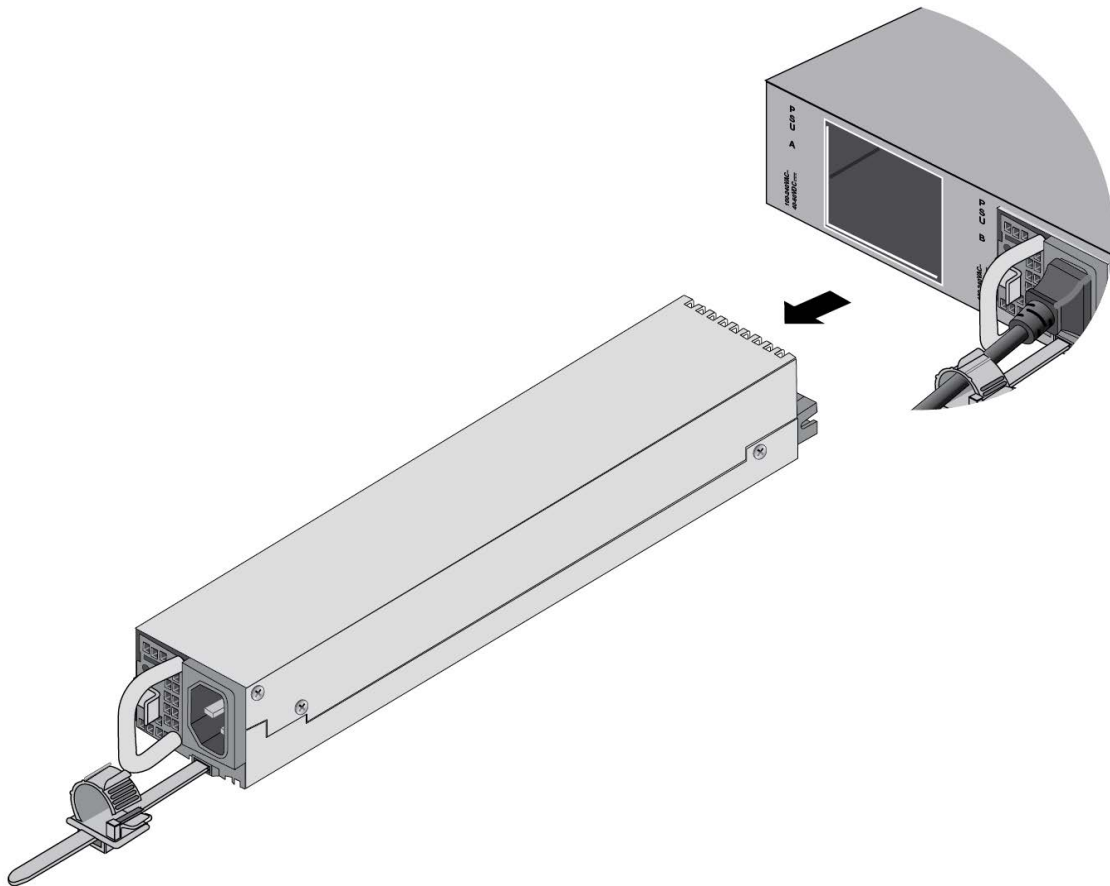

Figure 148. Removing the PWR600 Power Supply

6. Do one of the following:
 - To install a new power supply, refer to “Installing AT-PWR600 and AT-PWR600R AC Power Supplies” on page 128 or “Installing AT-PWR600-80 and AT-PWR600R-80 DC Power Supplies” on page 132 for instructions.
 - If you are not installing a new power supply, continue with the next step to install the blank panel
7. Orient the blank power supply cover as shown in Figure 149 on page 257 and slide it into the slot until it clicks into place.

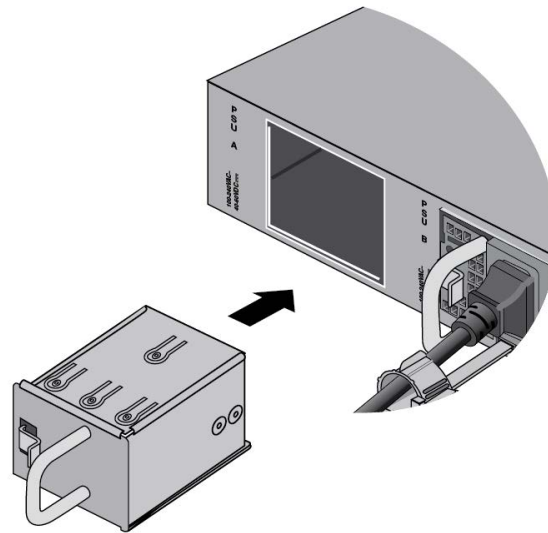

Figure 149. Installing the Blank Power Supply Cover

Replacing AT-PWR600-80 and AT-PWR600R-80 DC Power Supplies

This section contains the procedure for removing or replacing AT-PWR600-80 and AT-PWR600R-80 DC Power Supplies.

Note

Allied Telesis recommends saving a backup copy of the configuration file in the switch before removing or replacing power supplies. For instructions, refer to the Software Reference for x950 Switches.

To remove DC power supplies from the switch, perform the following procedure:

1. Power off the DC power source.
2. Loosen the screw for the connector panel with a Phillips-head screwdriver. Refer to Figure 150.

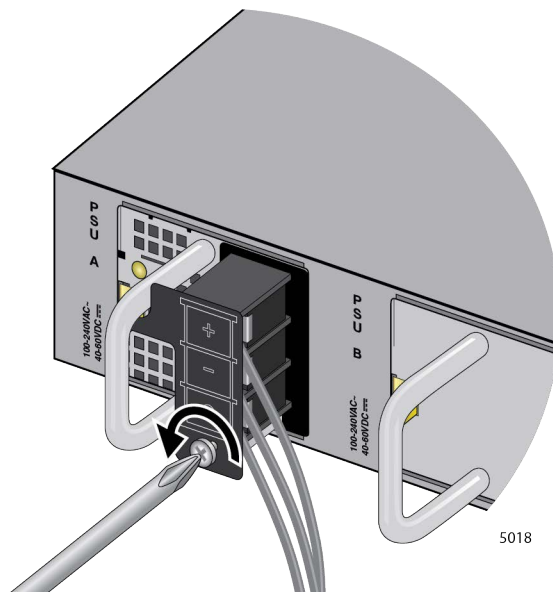

Figure 150. Loosening the Screw for the Panel

3. Press the panel to the right to access the connecting screws. Refer to Figure 151 on page 259.

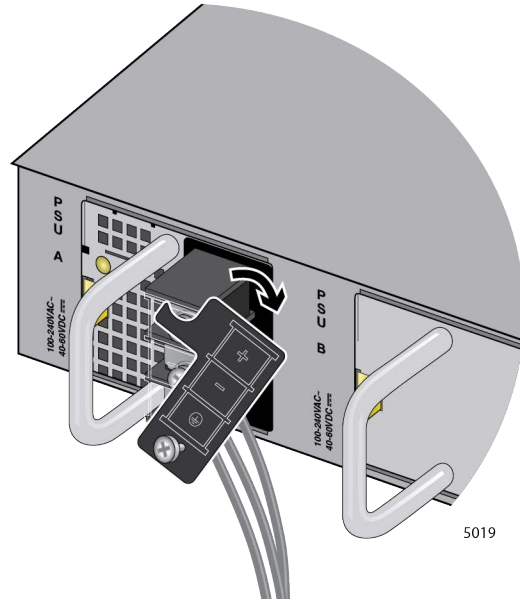

Figure 151. Accessing the Connecting Screws

4. Loosen the three screws for the ground wire, positive(+) and negative(-) wires.
5. Remove all three wires.
6. Press the release lever to the right and pull on the handle to release the power supply from the internal connector in the switch. Refer to Figure 152.

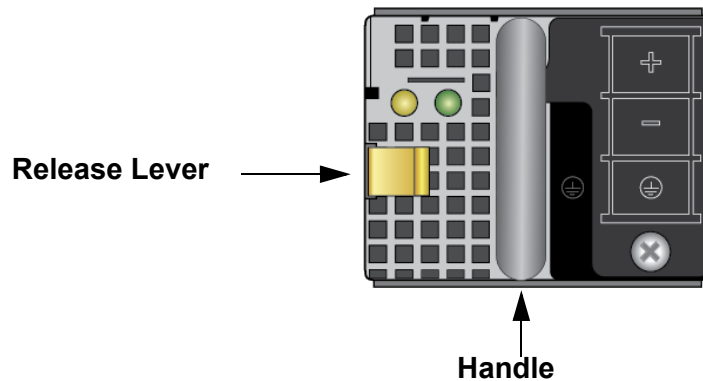

Figure 152. Front Panel of the PWR600 DC Power Supply

7. Carefully slide the power supply from the switch. Refer to Figure 153 on page 260.



Caution

The device is heavy. Use both hands to lift it. You might injure yourself or damage the device if you drop it. E94

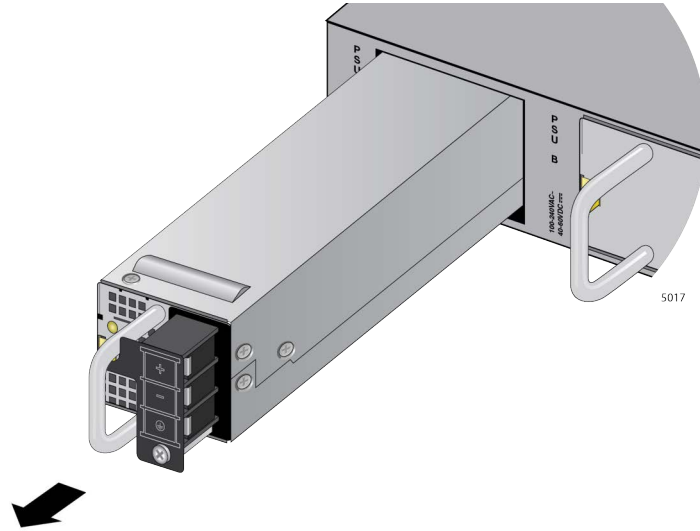

Figure 153. Removing the PWR600 DC Power Supply

8. Do one of the following:
 - To install a new power supply, go to “Installing AT-PWR600 and AT-PWR600R AC Power Supplies” on page 128 or “Installing AT-PWR600-80 and AT-PWR600R-80 DC Power Supplies” on page 132 for instructions.
 - If you are not installing a new power supply, continue with the next step to install the blank power supply cover.
9. Orient the blank power supply cover as shown in Figure 149 on page 257 and slide it into the slot until it clicks into place.
10. Remove the ground wire from the ground point at the installation site.

Replacing FAN05 Modules

This section contains the procedure for replacing AT-FAN05 and AT-FAN05R Fan Modules. Fan modules are hot swappable. You can replace them without having to power off the switch. For background information, refer to “AT-FAN05 and AT-FAN05R Fan Modules” on page 52.

Note

Allied Telesis recommends saving a backup copy of the configuration file in the switch before replacing a fan module. For instructions, refer to the Software Reference for x950 Switches.

Removing Fan Modules

This procedure requires the following tool:

- #2 Phillips-head screwdriver (not provided)

The illustrations show the removal of the fan module from FAN B slot on the back panel. The procedure is the same for removing a module from FAN A slot.

To remove a fan module from the switch, perform the following procedure:

1. Use a #2 Phillips-head screwdriver to loosen the two screws on the faceplate of the fan module. Refer to Figure 154.

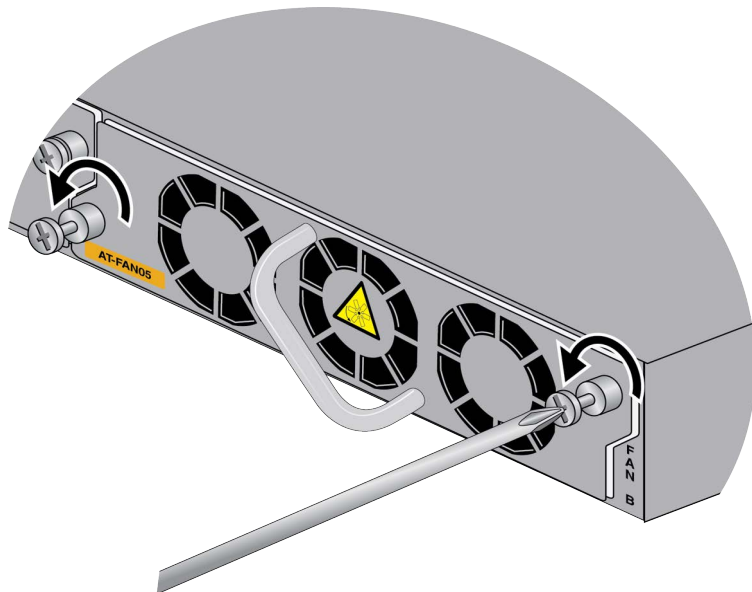

Figure 154. Loosening the Screws on the Fan Module

2. Carefully pull on the handle to disconnect the fan module from the internal connector in the switch. Refer to Figure 155.

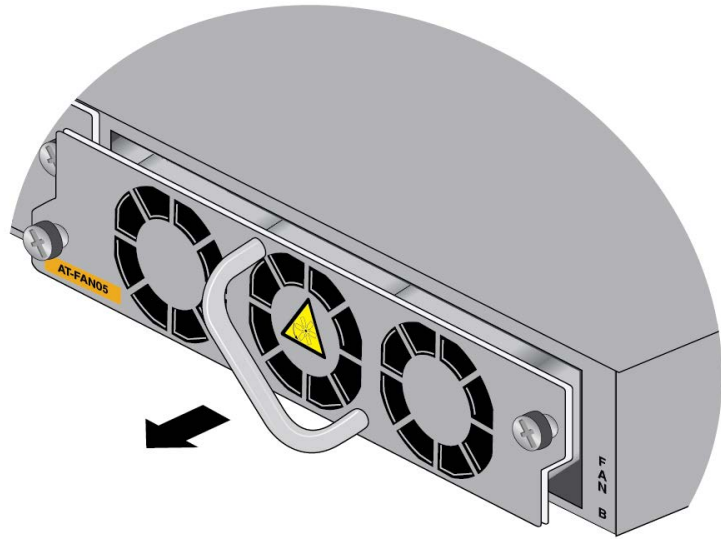

Figure 155. Disconnecting the FAN05 Module from the Switch

3. Slide the fan module out of the switch. Refer to Figure 156.

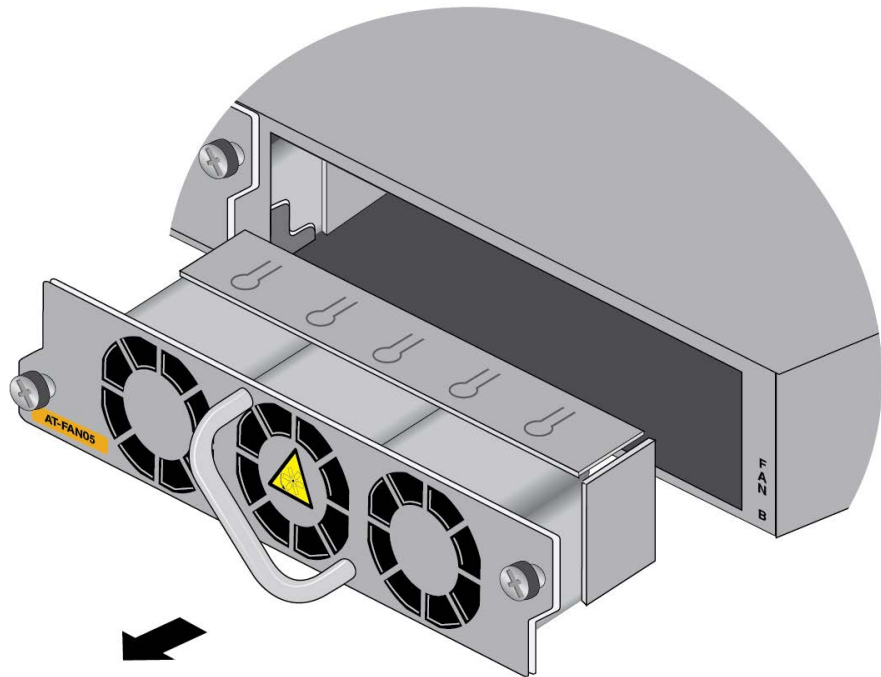

Figure 156. Sliding the Fan Module from the Switch

4. Continue with the next procedure to install a new FAN05 Module.

Installing Fan Modules

This procedure requires a #2 Phillips-head screwdriver (not provided).

The illustrations show the installation of a fan module in FAN B slot on the back panel. The procedure is the same for installing a module in FAN A slot.

To install a fan module, perform the following procedure:

1. Remove the new fan module from its shipping box. Refer to Figure 157.

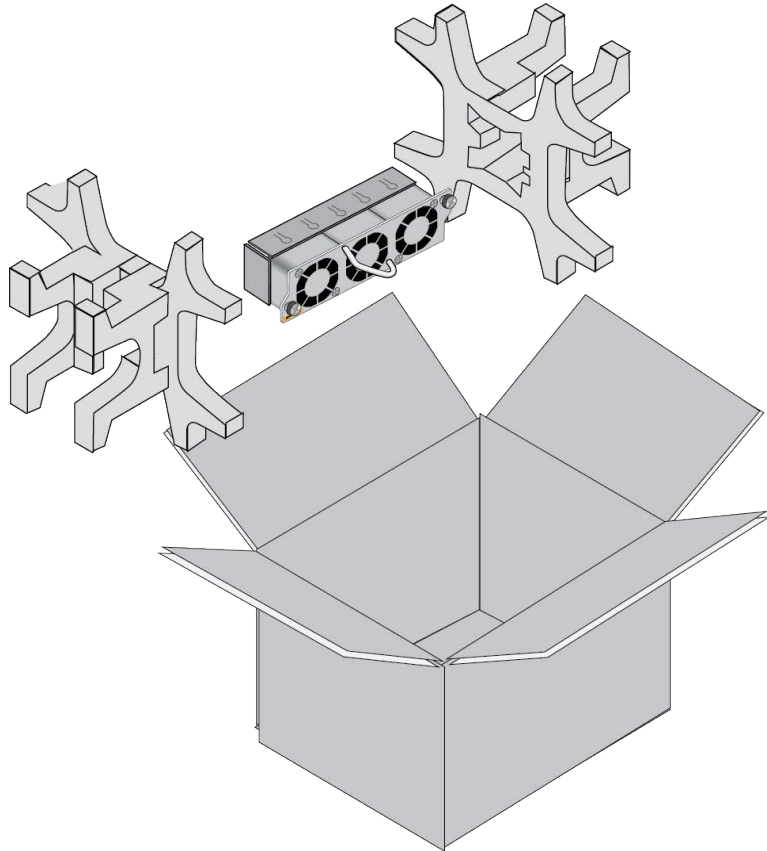

Figure 157. Removing the Fan Module from the Shipping Container

2. Align the fan module in the slot. Refer to Figure 158 on page 264.

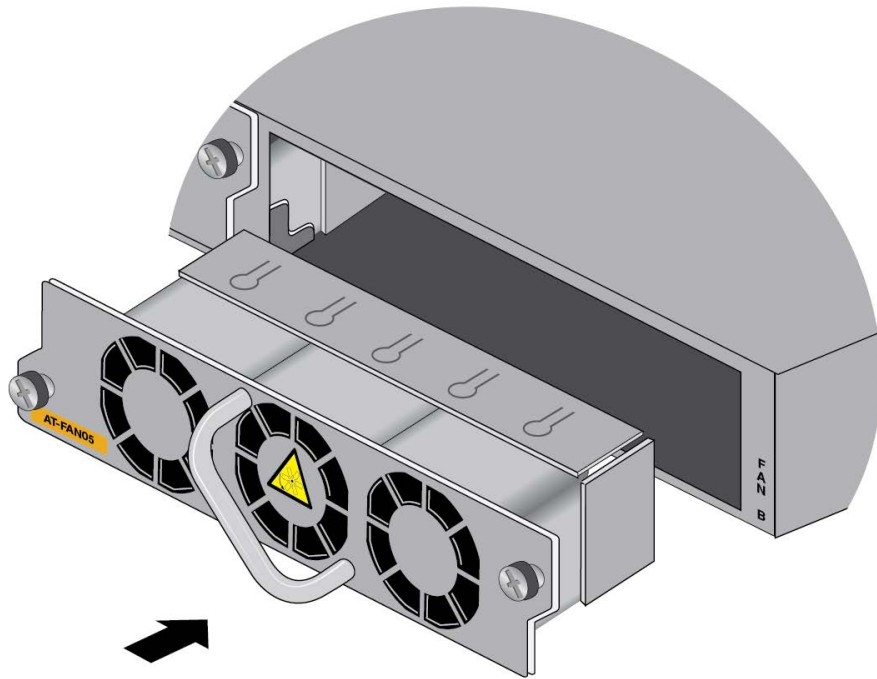

Figure 158. Aligning the FAN05 Module in the Switch Slot

3. When you feel the module make contact with the internal connector, gently press on both sides to seat the module on the connector. Refer to Figure 159.

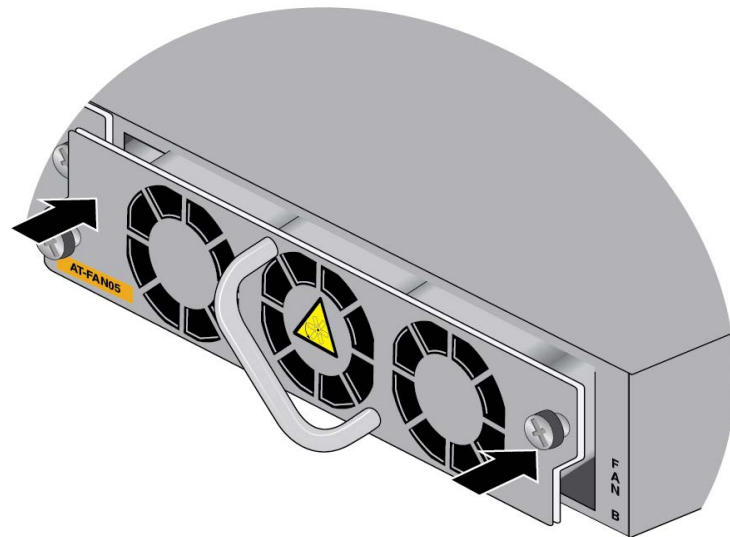

Figure 159. Seating the FAN05 Module on the Internal Connector

4. Tighten the two screws on the module to secure it to the switch. Refer to Figure 160.

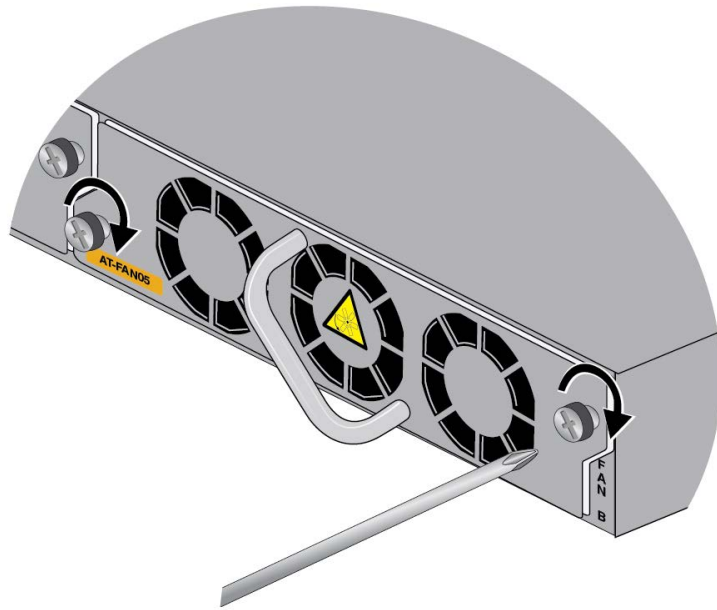

Figure 160. Tightening the Two Captive Screws on the FAN05 Module

5. To confirm the operations of the new fan module, start a local or remote management session and enter the `SHOW SYSTEM ENVIRONMENT` command in the User Exec or Privileged Exec mode.

Chapter 15

Troubleshooting

This chapter contains suggestions on how to troubleshoot problems with the switch.

Note

For further assistance, please contact Allied Telesis Technical Support at www.alliedtelesis.com/support.

Problem 1: The unit is not receiving power. All the port LEDs and Switch ID LED are off, and the fans are not operating.

Solutions: Try the following:

- Verify that the power cord is securely connected to the power source and AC connector on the back panel of the switch.
- Verify that the DC power wires are securely connected to the screws on the front panel and to the DC power source unit.
- Verify that the power outlet has power by connecting another device to it.
- Try connecting the unit to another power source.
- Try a different power cord.
- Verify that the voltage from the power source is within the required levels for your region. The power requirements for the switch are listed in “Power Specifications” on page 279.
- Try replacing the power supply.

Note

Power supplies are hot swappable. If the chassis has two power supplies and one fails, you can replace the failed unit without having to power off the operational power supply.

Problem 2: All the port LEDs are off even though the ports are connected to active network devices.

Solution: The switch might be operating in the low power mode. To toggle on the LEDs, press the eco-friendly button on the front panel of the switch. You can also toggle the LEDs off and on with the ECOFRIENDLY LED and NO ECOFRIENDLY LED commands in the command line interface.

Problem 3: A 1G or 10G fiber optic transceiver in a base port (ports 1 to 24) of the AT-x950-28XSQ Switch or AT-x950-52XSQ Switch (ports 1 to 48) is unable to establish a link to a network device.

Solutions: Try the following:

- ❑ Check that the transceiver is fully inserted in the port.
- ❑ Verify that the fiber optic cable is securely connected to the port on the transceiver and the remote network device.
- ❑ Verify that the remote network device is operating properly.
- ❑ Verify that the operating specifications of the fiber optic ports on the transceiver and remote network device are compatible.
- ❑ Verify that the correct type of fiber optic cabling is being used.
- ❑ Verify that the port is connected to the correct fiber optic cable.
- ❑ Try connecting another network device to the fiber optic port using a different cable. If the port is able to establish a link, then the problem is with the cable or with the other network device.
- ❑ Use the switch's management software to verify that the port is enabled.
- ❑ If the remote network device is a managed device, use its management firmware to determine whether its port is enabled.
- ❑ If the problem is with two BiDi (bi-directional) transceivers, refer to their data sheets to verify that their transmission and reception frequencies are opposite each other. For instance, a BiDi transceiver that transmits and receives at 1310nm and 1550nm, respectively, has to be connected to a transceiver that transmits and receives at 1550nm and 1310nm, respectively. Two BiDi transceivers will not establish a link if they transmit and receive at the same frequencies.
- ❑ Test the attenuation of both directions on the fiber optic cable with a fiber optic tester to determine whether the optical signal is too weak or strong.

Problem 4: A 40G or 100G fiber optic transceiver in port 25, 29, 33, or 37 on the AT-x950-28XSQ or AT-x950-28XTQm Switch, or port 49, 53, 57, or 61 on AT-x950-52XSQ or AT-x950-52XTQm Switch cannot establish a link with a network device.

Solutions: Try the following:

- ❑ Review the solutions to Problem 3.
- ❑ Use the SHOW PLATFORM command to confirm that the port is configured correctly for the transceiver. If necessary, use the PLATFORM PORTMODE INTERFACE command to configure the port. For more information, refer to "PLATFORM PORTMODE INTERFACE" on page 198.

Changing a port from a 40G transceiver or breakout cable to a 100G transceiver requires resetting the switch. The same is also true when replacing a 100G transceiver with a 40G transceiver or breakout cable.

- ❑ If the problem is with an 100G transceiver, you might need to adjust the Forward Error Correction (FEC) parameter on the port, with the FEC command. Refer to the *Software Reference for x950 Switch, AlliedWare Plus Operating System*.

Problem 5: A 4x10G breakout cable in port 25, 29, 33, or 37 in the AT-x950-28XSQ or AT-x950-28XTQm Switch, or port 49, 53, 57, or 61 in the AT-x950-52XSQ or AT-x950-52XTQm Switch cannot establish links with network devices.

Solutions: Try the following:

- ❑ Check that the cable is fully inserted in the port.
- ❑ Verify that the breakout cables are securely connected to the ports on the network devices.
- ❑ Use the SHOW PLATFORM command to confirm that the port is configured for a breakout cable. If necessary, use the PLATFORM PORTMODE INTERFACE command to configure the port. For more information, refer to “PLATFORM PORTMODE INTERFACE” on page 198.
- ❑ If the port previously had a 100G transceiver, you must reset the switch after configuring it for a breakout cable.

Problem 6: An XEM2 Line Card in the expansion slot is not functioning.

Solutions: Try the following:

- ❑ Visually inspect the card to verify that it is fully inserted into the expansion slot.
- ❑ If the problem is with an XEM2-12XTm Card, the switch might have an earlier version of the AlliedWare Plus software that does not support the card. The card requires v5.4.9-1 or later. Use the SHOW VERSION command to display the version number.
- ❑ Try installing the card in a different switch. If it still does not work, the problem is probably with the card. Replace the card.
- ❑ Try installing a different card in the switch. If the replacement card fails to work, the problem is probably with the switch. Contact your Allied Telesis sales representative for assistance.

Problem 7: An SFP, SFP+, or QSFP+ transceiver in an XEM2 Line Card is unable to establish a link to another network device.

Solutions: Try the solutions to Problem 3.

Problem 8: A copper port on the AT-x950-28XTQm or AT-x950-52XTQm Switch or an XEM2 Line Card cannot establish a link with a network device.

Solutions: Try the following:

- ❑ Verify that the network device connected to the twisted pair port is powered on and is operating properly.
- ❑ Verify that the network device operates at a speed supported by the card. The ports on the XEM2-12XT Card support 100M/1G/10G. The ports on the AT-x950-28XTQm and AT-x950-52XTQm Switches, XEM2-8XSTm and XEM2-12XTm Cards support 100M/1G/2.5G/5G/10G. The ports do not support 10M devices.
- ❑ If the XEM2-12XT Card cannot establish links with 100M devices, the switch might have an earlier version of the AlliedWare Plus management software. Support for 100M devices on the XEM2-12XT Card requires version 5.4.9-1 or later. Use the SHOW VERSION command to display the version number. If necessary, update the management software.
- ❑ Try connecting another network device to the copper port with a different cable. If the copper port is able to establish a link, then the problem is with the cable or the other network device.
- ❑ Verify that the copper cable does not exceed 100 meters (328 feet).
- ❑ Verify that you are using the appropriate category of copper cable. Refer to “Cabling Copper Ports” on page 236.
- ❑ Verify that the port is connected to the correct cable.

Note

1G/10G connections may require five to ten seconds to establish links.

Problem 9: The SHOW STACK command is not displaying all the switches in the stack.

Solutions: The switches are unable to form the stack. Try the following:

- ❑ The switches might have an earlier version of the management software that does not support VCStack, or they might have different versions. The version must be 5.4.8-2 or later. You can view the version number with the SHOW VERSION command.
- ❑ Review the information in “Stack Trunks” on page 84 to verify that the trunk complies with all rules and restrictions.
- ❑ If the trunk is using fiber optic transceivers, verify that they are fully and securely inserted into the ports.
- ❑ Verify that the transceivers are from Allied Telesis.

- ❑ Verify that the fiber optic cables are securely connected to the ports on the transceivers.
- ❑ Display the running configurations and confirm the ports of the stack trunk. They are identified by the STACKPORT command. In this example from a running configuration, ports 1 to 4 are the stack trunk:

```
interface port1.0.1-1.0.4
  stackport
```
- ❑ If necessary, repeat the STACKPORT command. For information, refer to “STACKPORT” on page 199. Afterwards, save your changes and reboot the switch.

Problem 10: A port removed from a stack trunk with the NO STACKPORT command is still not forwarding regular Ethernet traffic.

- ❑ Display the running configuration to verify that the port is no longer part of the stack trunk.
- ❑ You have to reboot the switch whenever you add or remove ports from stack trunks with the STACKPORT and NO STACKPORT commands. Be sure to save the change to the configuration file with the WRITE command before rebooting the unit.

Problem 11: The switch overheats and shuts down.

Solutions: Try the following:

- ❑ Verify that the location of the switch allows for adequate airflow.
- ❑ If the switch is operating, use the SHOW SYSTEM ENVIRONMENT command in the Privileged Exec mode to verify that the power supplies and fan modules are operating properly.
- ❑ Verify that the power supplies and fan modules have the same airflow direction. Refer to Table 13 on page 44 and Table 16 on page 52 for airflow information.

Problem 12: The System Airflow status in the SHOW SYSTEM ENVIRONMENT command displays “INCOMPATIBLE.”

Solution: The power supplies and fan modules in the switch have different airflow directions. Refer to Table 13 on page 44 and Table 16 on page 52 for airflow information. Replace power supplies and/or fan modules so that they have the same airflow direction.

Problem 13: The switch functions intermittently.

Solutions: Try the following:

- ❑ Use the SHOW SYSTEM ENVIRONMENT command in the Privileged Exec mode to verify that the input voltage from the power source to the switch is stable and within the approved operating range. The unit will shut down if the input voltage fluctuates above or below the approved operating range.
- ❑ Use the SHOW SYSTEM ENVIRONMENT command in the Privileged Exec mode to verify that the fan modules are operating correctly.
- ❑ Verify that the location of the switch allows for adequate airflow. The unit will shut down if it overheats.
- ❑ Verify that the power supplies and fan modules have the same airflow direction. Refer to Table 13 on page 44 and Table 16 on page 52.

Problem 14: The Switch ID LED in the management panel is flashing “F.”

Solutions: One of the following problems has occurred:

- ❑ A cooling fan has failed. Use the SHOW SYSTEM ENVIRONMENT command to verify that the fan modules are operating correctly.
- ❑ The internal temperature of the switch is outside the normal operating range and the unit might shut down. The installation site might not provide enough ventilation for the device. Increase the ventilation at the site.
- ❑ Verify that the power supplies and fan modules have the same airflow direction. Refer to Table 13 on page 44 and Table 16 on page 52.

Appendix A

Technical Specifications

This appendix contains the following sections:

- "Physical Specifications" on page 274
- "Environmental Specifications" on page 278
- "Power Specifications" on page 279
- "Certifications" on page 289
- "RJ-45 Twisted Pair Port Pinouts" on page 290
- "RJ-45 Style Serial Console Port Pinouts" on page 292

Physical Specifications

Dimensions (H x W x D)

Table 49 lists the dimensions of the switches and power supplies.

Table 49. Product Dimensions

AT-x950-28XSQ AT-x950-28XTQm	4.4 cm x 44.0 cm x 44.5 cm (1.7 in. x 17.3 in. x 17.5 in.)
AT-x950-52XSQ AT-x950-52XTQm	4.4 cm x 44.0 cm x 44.7 cm (1.7 in. x 17.3 in. x 17.6 in.)
AT-XEM2-8XSTm Line Card AT-XEM2-12XT Line Card AT-XEM2-12XTm Line Card AT-XEM2-12XS Line Card AT-XEM2-12XS v2 Line Card AT-XEM2-4QS Line Card AT-XEM2-1CQ Line Card	4.0 x 13.0 x 16.6 cm (1.57 x 5.11 x 6.53 in.)
AT-PWR600 AC and AT-PWR600R AC	5.1 cm x 4.0 cm x 24.5 cm (2.0 in. x 1.6 in. x 9.6 in.)
AT-PWR600-80 DC and AT-PWR600R-80 DC	5.1 cm x 4.0 cm x 24.5 cm (2.0 in. x 1.6 in. x 9.6 in.)
AT-FAN05 and AT-FAN05R	4.3 cm x 15.2 cm x 10.0 cm (1.7 in. x 6.0 in. x 3.9 in.)

Width (All Models)

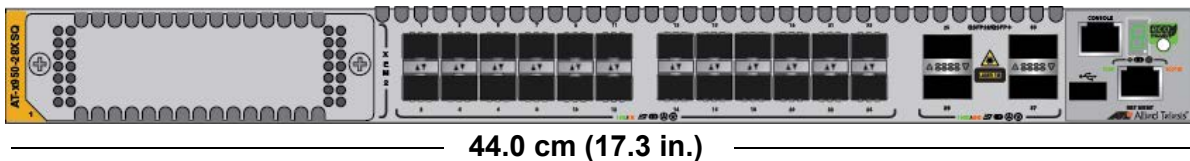

Height (All Models)

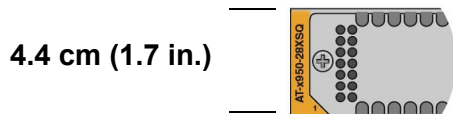
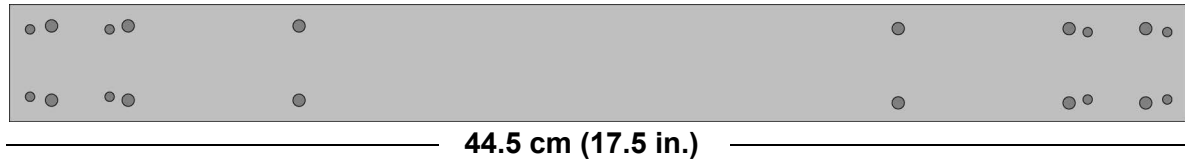

Figure 161. Switch Width and Height

The side dimension and locations of the bracket holes for the AT-x950-28XSQ and AT-x950-28XTQm Switches are shown in Figure 162.

Depth: AT-x950-28XSQ and AT-x950-28XTQm



Bracket Hole Locations: AT-x950-28XSQ and AT-x950-28XTQm

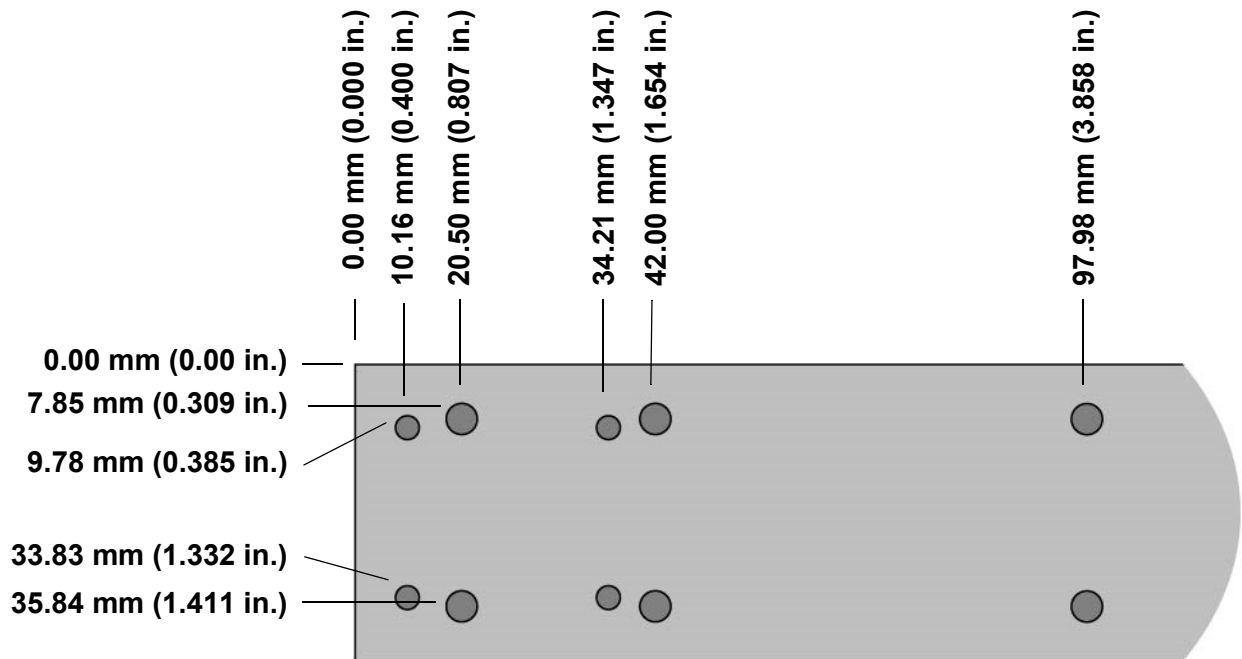
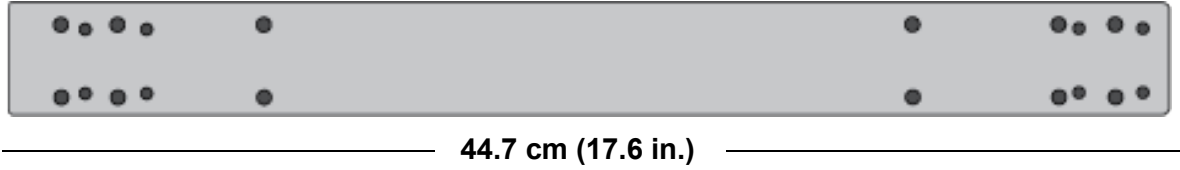

Figure 162. Switch Depth and Locations of Bracket Holes for the AT-x950-28XSQ and AT-x950-52XTQm Switches

The side dimension and bracket holes for the AT-x950-52XSQ and AT-x950-52XTQm Switches are shown in Figure 163.

Depth: AT-x950-52XSQ and AT-x950-52XTQm



Bracket Hole Locations: AT-x950-52XSQ and AT-x950-52XTQm

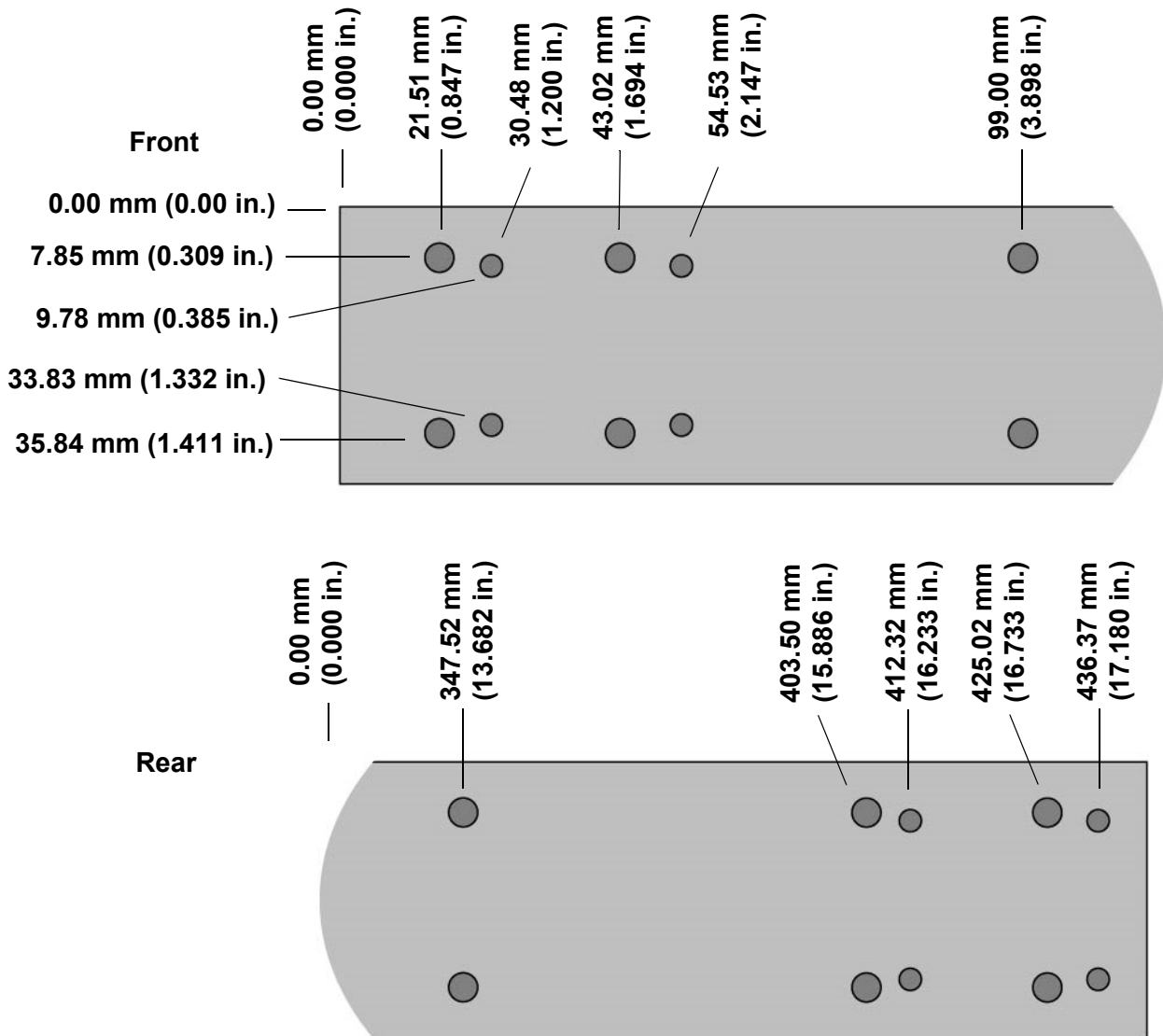

Figure 163. Switch Depth and Bracket Holes for x950-52XSQ and x950-52XTQm Switches

Weights

Table 50 lists the weights of the switch and components.

Table 50. Product Weights

AT-x950-28XSQ Switch	7.21 kg (15.90 lb.)
AT-x950-28XTQm Switch	7.33 kg (16.15 lb.)
AT-x950-52XSQ Switch	7.35 kg (16.2 lb.)
AT-x950-52XTQm Switch	8.20 kg (18.08 lb.)
AT-XEM2-8XSTm Line Card	0.70 kg (1.54 lb.)
AT-XEM2-12XT Line Card	0.75 kg (1.65 lb.)
AT-XEM2-12XTm Line Card	1.04 kg (2.3 lb.)
AT-XEM2-12XS Line Card	0.75 kg (1.65 lb.)
AT-XEM2-12XS v2 Line Card	0.73 kg (1.60 lb.)
AT-XEM2-4QS Line Card	0.66 kg (1.45 lb.)
AT-XEM2-1CQ Line Card	0.62 kg (1.37 lb.)
AT-PWR600 and AT-PWR600R AC Power Supplies	0.68 kg (1.5 lb.)
AT-PWR600-80 and AT-PWR600R-80 DC Power Supplies	0.77 kg (1.7 lb.)
AT-FAN05 and AT-FAN05R Fan Modules	0.34 kg (0.75 lb.)

The weights of the switches include two cooling fan modules. They do not include power supplies or line card.

Ventilation

Table 51 lists the ventilation requirements.

Table 51. Ventilation Requirements

Recommended Minimum Ventilation on All Sides	10 cm (4.0 in)
---	----------------

Environmental Specifications

Table 52 lists the environmental specifications of the switches.

Table 52. Environmental Specifications

Operating Temperature (with QSFP28 transceivers)	0° C to 45° C (32° F to 113° F)
Operating Temperature (without QSFP28 transceivers)	0° C to 50° C (32° F to 122° F)
Storage Temperature	-25° C to 70° C (-13° F to 158° F)
Operating Humidity	5% to 90% noncondensing
Storage Humidity	5% to 95% noncondensing
Maximum Operating Altitude	3,000 m (9,842 ft)
Maximum Nonoperating Altitude	4,000 m (13,100 ft)

Power Specifications

This section contains the maximum power consumption values and input voltages.

Maximum Power Consumptions

Table 53 list the maximum power consumptions for the AT-x950-28XSQ Switch.

Table 53. Maximum Power Consumptions (Watts) for the AT-x950-28XSQ Switch

AT-x950-28XSQ Switch and Line Card	PWR600	Number of Power Supplies	Maximum Power Consumption
Switch - No card	AC	1	206.08 W
		2	231.22 W
	DC	1	201.85 W
		2	218.66 W
Switch plus AT-XEM2-4QS Card	AC	1	224.55 W
		2	248.04 W
	DC	1	219.80 W
		2	236.11 W
Switch plus AT-XEM2-12XT Card	AC	1	251.07 W
		2	271.85 W
	DC	1	246.27 W
		2	261.69 W
Switch plus AT-XEM2-12XS Card	AC	1	240.40 W
		2	262.30 W
	DC	1	235.66 W
		2	251.44W

Table 53. Maximum Power Consumptions (Watts) for the AT-x950-28XSQ Switch (Continued)

AT-x950-28XSQ Switch and Line Card	PWR600	Number of Power Supplies	Maximum Power Consumption
Switch plus AT-XEM2-1CQ Card	AC	1	213.63 W
		2	238.19 W
	DC	1	209.36 W
		2	226.04 W
Switch plus AT-XEM2-12XTm Card	AC	1	239.96 W
		2	261.64 W
	DC	1	233.73 W
		2	249.67 W
Switch plus AT-XEM2-12XS v2 Card	AC	1	233.38 W
		2	256.32 W
	DC	1	227.97 W
		2	244.19 W
Switch plus AT-XEM2-8XSTm Card	AC	1	226.71 W
		2	250.27 W
	DC	1	221.56 W
		2	237.91 W

Table 54 list the maximum power consumptions for the AT-x950-28XTQm Switch.

Table 54. Maximum Power Consumptions (Watts) for the AT-x950-28XTQm Switch

AT-x950-28XTQm Switch and Line Card	PWR600	Number of Power Supplies	Maximum Power Consumption
Switch - No card	AC	1	234.55 W
		2	255.26 W
	DC	1	222.55 W
		2	238.80 W
Switch plus AT-XEM2-4QS Card	AC	1	253.19 W
		2	271.68 W
	DC	1	240.59 W
		2	256.15 W
Switch plus AT-XEM2-12XT Card	AC	1	280.51 W
		2	295.82 W
	DC	1	267.19 W
		2	281.79 W
Switch plus AT-XEM2-12XS Card	AC	1	269.62 W
		2	286.18 W
	DC	1	256.71 W
		2	271.49 W
Switch plus AT-XEM2-1CQ Card	AC	1	241.95 W
		2	261.74 W
	DC	1	230.07 W
		2	246.02 W

Table 54. Maximum Power Consumptions (Watts) for the AT-x950-28XTQm Switch (Continued)

AT-x950-28XTQm Switch and Line Card	PWR600	Number of Power Supplies	Maximum Power Consumption
Switch plus AT-XEM2-12XTm Card	AC	1	267.89 W
		2	284.63 W
	DC	1	254.83 W
		2	269.90 W
Switch plus AT-XEM2-12XS v2 Card	AC	1	261.97 W
		2	280.37 W
	DC	1	248.92 W
		2	264.26 W
Switch plus AT-XEM2-8XSTm Card	AC	1	255.31 W
		2	273.90 W
	DC	1	242.46 W
		2	258.15 W

Table 55 lists the maximum power consumptions for the AT-x950-52XSQ Switch.

Table 55. Maximum Power Consumptions (Watts) for the AT-x950-52XSQ Switch

	PWR600	Number of Power Supplies	Maximum Power Consumption
AT-x950-52XSQ Switch	AC	1	246.26 W
		2	266.12 W
	DC	1	229.90 W
		2	247.40 W

Table 56 lists the maximum power consumptions for the AT-x950-52XTQm Switch.

Table 56. Maximum Power Consumptions (Watts) for the AT-x950-52XTQm Switch

	PWR600	Number of Power Supplies	Maximum Power Consumption
AT-x950-52XTQm Switch	AC	1	274.04 W
		2	291.09 W
	DC	1	263.10 W
		2	273.30 W

Typical Power Savings in eco-friendly Mode

Table 57 lists the typical power savings in eco-friendly mode for the AT-x950-28XSQ Switch.

Table 57. Typical Power Savings in eco-friendly Mode (Watts) for the AT-x950-28XSQ Switch

AT-x950-28XSQ Switch and Line Card	Power Savings
Switch - No card	0.53 W
Switch plus AT-XEM2-4QS Card	0.64 W
Switch plus AT-XEM2-12XT Card	0.64 W
Switch plus AT-XEM2-12XS Card	0.66 W
Switch plus AT-XEM2-1CQ Card	0.55 W
Switch plus AT-XEM2-12XTm Card	0.64 W
Switch plus AT-XEM2-12XS v2 Card	0.84 W
Switch plus AT-XEM2-8XSTm Card	0.81 W

Table 58 lists the typical power savings in eco-friendly mode for the AT-x950-28XTQm Switch.

Table 58. Typical Power Savings in eco-friendly Mode (Watts) for the AT-x950-28XTQm Switch

AT-x950-28XTQm Switch and Line Card	Power Savings
Switch - No card	0.73 W
Switch plus AT-XEM2-4QS Card	0.84 W
Switch plus AT-XEM2-12XT Card	0.84 W
Switch plus AT-XEM2-12XS Card	0.86 W
Switch plus AT-XEM2-1CQ Card	0.75 W
Switch plus AT-XEM2-12XTm Card	0.84 W
Switch plus AT-XEM2-12XS v2 Card	0.84 W
Switch plus AT-XEM2-8XSTm Card	0.81 W

Input Voltage

Table 59 lists the input voltage for the power supply.

Table 59. Input Voltages

	AC	DC
AT-x950-28XSQ Switch	100-240 VAC~, 4A maximum, 50/60 Hz (per inputx2)	40-60V DC, 6.0A (per Input x2)
AT-x950-28XTQm Switch	100-240 VAC~, 4A maximum, 50/60 Hz (per inputx2)	40-60V DC, 6.0A (per Input x2)
AT-x950-52XSQ Switch	100-240 VAC~, 4A maximum, 50/60 Hz (per inputx2)	40-60V DC, 6.0A (per Input x2)
AT-x950-52XTQm Switch	100-240 VAC~, 4A maximum, 50/60 Hz (per inputx2)	40-60V DC, 6.0A (per Input x2)
PWR600 AC	100-240 VAC~, 8.7A maximum, 50/60 Hz (per input)	N/A
PWR600 DC	N/A	40-72 VDC, 6.0A maximum

Maximum Power Supply Efficiency

Table 60 lists the maximum power supply efficiency.

Table 60. Maximum Power Supply Efficiency (Based on 100V Input Voltage)

PWR600 AC Power Supply	Up to 85%
------------------------	-----------

Heat Dissipations

Table 61 lists the heat dissipations for the AT-x950-28XSQ Switch.

Table 61. Heat Dissipations for the AT-x950-28XSQ Switch

AT-x950-28XSQ Switch and Line Card	PWR600	Number of Power Supplies	Heat Dissipation (British Thermal Units/Hour)
Switch - No card	AC	1	703.24 BTU/hr
		2	789.03 BTU/hr
	DC	1	688.80 BTU/hr
		2	746.16 BTU/hr
Switch plus AT-XEM2-4QS Card	AC	1	766.27 BTU/hr
		2	846.43 BTU/hr
	DC	1	750.05 BTU/hr
		2	805.71 BTU/hr
Switch plus AT-XEM2-12XT Card	AC	1	856.77 BTU/hr
		2	927.68 BTU/hr
	DC	1	840.40 BTU/hr
		2	893.01 BTU/hr
Switch plus AT-XEM2-12XS Card	AC	1	820.36 BTU/hr
		2	895.09 BTU/hr
	DC	1	804.17 BTU/hr
		2	858.03 BTU/hr

Table 61. Heat Dissipations for the AT-x950-28XSQ Switch (Continued)

AT-x950-28XSQ Switch and Line Card	PWR600	Number of Power Supplies	Heat Dissipation (British Thermal Units/Hour)
Switch plus AT-XEM2-1CQ Card	AC	1	729.01 BTU/hr
		2	812.82 BTU/hr
	DC	1	714.43 BTU/hr
		2	771.36 BTU/hr
Switch plus AT-XEM2-12XTm Card	AC	1	818.86 BTU/hr
		2	892.84 BTU/hr
	DC	1	797.61 BTU/hr
		2	851.99 BTU/hr
Switch plus AT-XEM2-12XS v2 Card	AC	1	796.40 BTU/hr
		2	874.69 BTU/hr
	DC	1	777.95 BTU/hr
		2	833.31 BTU/hr
Switch plus AT-XEM2-8XSTm Card	AC	1	773.64 BTU/hr
		2	854.04 BTU/hr
	DC	1	756.07 BTU/hr
		2	811.85 BTU/hr

Table 62 lists the heat dissipations for the AT-x950-28XTQm Switch.

Table 62. Heat Dissipations for the AT-x950-28XTQm Switch

AT-x950-28XTQm Switch and Line Card	PWR600	Number of Power Supplies	Heat Dissipation (British Thermal Units/Hour)
Switch - No card	AC	1	800.40 BTU/hr
		2	871.07 BTU/hr
	DC	1	759.43 BTU/hr
		2	814.90 BTU/hr
Switch plus AT-XEM2-4QS Card	AC	1	864.01 BTU/hr
		2	927.10 BTU/hr
	DC	1	821.00 BTU/hr
		2	874.12 BTU/hr
Switch plus AT-XEM2-12XT Card	AC	1	957.23 BTU/hr
		2	1009.48 BTU/hr
	DC	1	911.79 BTU/hr
		2	961.62 BTU/hr
Switch plus AT-XEM2-12XS Card	AC	1	920.07 BTU/hr
		2	976.58 BTU/hr
	DC	1	876.02 BTU/hr
		2	926.45 BTU/hr
Switch plus AT-XEM2-1CQ Card	AC	1	825.65 BTU/hr
		2	893.18 BTU/hr
	DC	1	785.09 BTU/hr
		2	839.52 BTU/hr
Switch plus AT-XEM2-12XTm Card	AC	1	914.17 BTU/hr
		2	971.29 BTU/hr
	DC	1	869.62 BTU/hr
		2	921.01 BTU/hr

Table 62. Heat Dissipations for the AT-x950-28XTQm Switch (Continued)

AT-x950-28XTQm Switch and Line Card	PWR600	Number of Power Supplies	Heat Dissipation (British Thermal Units/Hour)
Switch plus AT-XEM2-12XS v2 Card	AC	1	893.97 BTU/hr
		2	956.76 BTU/hr
	DC	1	849.44 BTU/hr
		2	901.77 BTU/hr
Switch plus AT-XEM2-8XSTm Card	AC	1	871.24 BTU/hr
		2	934.68 BTU/hr
	DC	1	827.40 BTU/hr
		2	880.92 BTU/hr

Table 63 list the heat dissipations for the AT-x950-52XSQ Switch.

Table 63. Heat Dissipations for the AT-x950-52XSQ Switch

Switch	PWR600	Number of Power Supplies	Heat Dissipation (British Thermal Units/Hour)
AT-x950-52XSQ Switch	AC	1	840.36 BTU/hr
		2	908.13 BTU/hr
	DC	1	784.53 BTU/hr
		2	844.25 BTU/hr

Table 64 list the heat dissipations for the AT-x950-52XTQm Switch.

Table 64. Heat Dissipations for the AT-x950-52XTQm Switch

Switch	PWR600	Number of Power Supplies	Heat Dissipation (British Thermal Units/Hour)
AT-x950-52XTQm Switch	AC	1	935.16 BTU/hr
		2	993.34 BTU/hr
	DC	1	897.82 BTU/hr
		2	932.63 BTU/hr

Certifications

Table 65 lists the product certificates.

Table 65. Product Certifications

EMI (Emissions)	FCC Class A CISPR 22 Class A EN 55032 Class A VCCI Class A ICES-003 Class A RCM
EMC (Immunity)	EN 55024 EN 61000-3-2 EN 61000-3-3
Electrical and Laser Safety	UL 60950-1 (cUL _{US}) EN 62368-1 (TUV) EN 60825-1
RoHS	RoHS6

RJ-45 Twisted Pair Port Pinouts

Figure 164 illustrates the pin layout of the RJ-45 connectors on the following products:

- ❑ AT-x950-28XTQm Switch
- ❑ AT-x950-52XTQm Switch
- ❑ AT-XEM2-8XSTm Line Card
- ❑ AT-XEM2-12XT Line Card
- ❑ AT-XEM2-12XTm Line Card

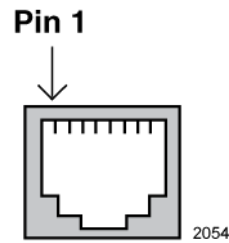

Figure 164. Pin Layout (Front View) of Twisted Pair Ports

Table 66 lists the pin signals at 100M.

Table 66. Pin Signals on RJ-45 Twisted Pair Ports at 100M

Pin	MDI Signal	MDI-X Signal
1	TX+	RX+
2	TX-	RX-
3	RX+	TX+
4	Not used	Not used
5	Not used	Not used
6	RX-	TX-
7	Not used	Not used
8	Not used	Not used

Table 67 lists the pin signals at 1G/2.5G/5G/10G.

Table 67. Pin Signals on Twisted Pair Ports at 1G/2.5G/5G/10G

Pin	Pair	Signal
1	1 +	TX and RX+
2	1 -	TX and RX-
3	2 +	TX and RX+
4	3 +	TX and RX+
5	3 -	TX and RX-
6	2 -	TX and RX-
7	4 +	TX and RX+
8	4 -	TX and RX-

RJ-45 Style Serial Console Port Pinouts

Table 68 lists the pin signals of the RJ-45 style serial Console port.

Table 68. RJ-45 Style Serial Console Port Pin Signals

Pin	Signal
1	Looped to pin 8
2	Looped to pin 7
3	Transmit Data
4	Ground
5	Ground
6	Receive Data
7	Looped to pin 2
8	Looped to pin 1