

# x980-32CQ and x980-32DQ

100 and 400 Gigabit Ethernet Stackable Switches

AlliedWare Plus™

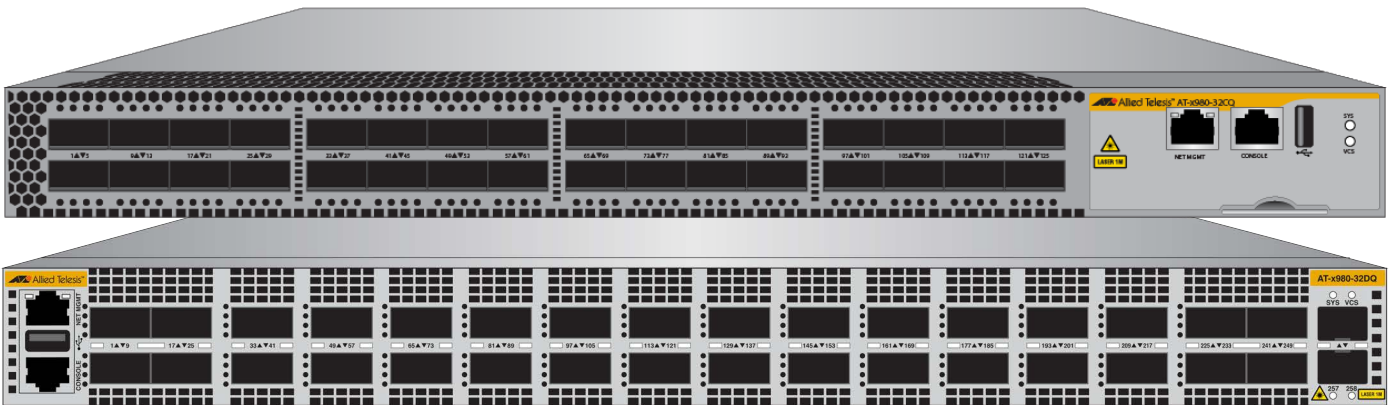

## Installation Guide

Copyright © 2026 Allied Telesis, Inc.

All rights reserved. No part of this publication may be reproduced without prior written permission from Allied Telesis, Inc.

Allied Telesis, VCStack, and the Allied Telesis logo are trademarks of Allied Telesis, Incorporated. All other product names, company names, logos or other designations mentioned herein are trademarks or registered trademarks of their respective owners.

Allied Telesis, Inc. reserves the right to make changes in specifications and other information contained in this document without prior written notice. The information provided herein is subject to change without notice. In no event shall Allied Telesis, Inc. be liable for any incidental, special, indirect, or consequential damages whatsoever, including but not limited to lost profits, arising out of or related to this manual or the information contained herein, even if Allied Telesis, Inc. has been advised of, known, or should have known, the possibility of such damages.

# Electrical Safety and Emissions Standards

---

This section contains the following:

- “US Federal Communications Commission”
- “Industry Canada”
- “Emissions, Immunity and Electrical Safety Standards” on page 4
- “Translated Safety Statements” on page 5

## US Federal Communications Commission

---

### Radiated Energy

---

**Note**

This equipment has been tested and found to comply with the limits for a Class A digital device pursuant to Part 15 of FCC Rules. These limits are designed to provide reasonable protection against harmful interference when the equipment is operated in a commercial environment. This equipment generates, uses, and can radiate radio frequency energy and, if not installed and used in accordance with this instruction manual, may cause harmful interference to radio communications. Operation of this equipment in a residential area is likely to cause harmful interference in which case the user will be required to correct the interference at his own expense.

---

**Note**

Modifications or changes not expressly approved of by the manufacturer or the FCC, can void your right to operate this equipment.

---

## Industry Canada

---

### Radiated Energy

This Class A digital apparatus complies with Canadian ICES-003.

Cet appareil numérique de la classe A est conforme à la norme NMB-003 du Canada.

# Emissions, Immunity and Electrical Safety Standards

---

Electrical Safety	x980-32CQ: UL62368-1 ed.3 CB IEC/EN 62368-1 ed.2 TUV T-mark EN62368-1 2014  x980-32DQ: UL62368-1 ed.3 CB IEC/EN 62368-1 ed.3 TUV T-mark EN IEC 62368-1 2020+A11
Electro Magnetic Interference	FCC Class A EN55032, Class A CISPR 32 VCCI Class A
Electro Magnetic Compatibility	ICES-003 Issue 7 (2020) EN55032+EN55035 EN300386 BS55032/55035



## Warning

In a domestic environment, this product may cause radio interference in which case the user may be required to take adequate measures. ⚡ E70

---

## Power Supply Safety Compliance

---



### Warning

This unit has more than one power input. To reduce the risk of electric shock, disconnect all power inputs before servicing the unit.



---

## Translated Safety Statements

---

**Important:** The  indicates that translations of the safety statement are available in the PDF document “Translated Safety Statements” posted on the Allied Telesis website at [alliedtelesis.com/support](http://alliedtelesis.com/support).



# Contents

---

<b>Preface</b> .....	9
Document Conventions .....	10
Translated Safety Statements .....	11
Contacting Allied Telesis .....	12
<b>Chapter 1: Overview</b> .....	13
Overview .....	14
x980-32CQ Switch .....	14
x980-32DQ Switch .....	15
Features .....	16
Hardware Features for the x980-32CQ Switch .....	16
Hardware Features for the x980-32DQ Switch .....	16
Virtual Chassis Stacking (VCStack) .....	16
SFP Slots .....	17
QSFP28 Slots on the x980-32CQ Switch .....	17
QSFP-DD Slots on the x980-32DQ Switch .....	17
SFP+ Slots on the x980-32DQ Switch .....	17
NET MGMT Port .....	18
CONSOLE Port (RS-232) .....	18
USB Port .....	18
Power Supply Units (PSUs) .....	19
FANs .....	19
Label Tag .....	20
Management Software and Interfaces .....	20
Management Methods .....	20
LEDs.....	21
LEDs for the MGMT, SYS, and VCS ID .....	21
LEDs for QSFP28 Slots .....	22
LEDs for QSFP-DD Slots .....	24
LEDs for SFP+ Slots .....	25
LEDs for PSUs and Fan Units .....	26
Designating Ports in the Command Line Interface .....	28
Port Number for the x980-32CQ Switch .....	28
Port Number for the x980-32DQ Switch .....	29
Examples for the PORT Parameters .....	30
<b>Chapter 2: Virtual Chassis Stacking</b> .....	31
Overview .....	32
Stacking Guidelines.....	33
General Stacking Guidelines .....	33
Stacking Port Guidelines .....	33
Stacking Ports Examples .....	35
VCStack with Two Switches and Two Ports.....	35
VCStack with Four Switches and Four Ports .....	35
Master and Member Switches .....	37
Selection of the Master Switch .....	37
Optional Feature Licenses .....	38
<b>Chapter 3: Beginning the Installation</b> .....	39
Reviewing Safety Precautions .....	40

Choosing a Site for the Chassis .....	44
Unpacking the Boxes and Verifying the Contents .....	45
Installation Options and Instructions .....	47
<b>Chapter 4: Installing the Switch in an Equipment Rack .....</b>	<b>49</b>
Overview of Installing the Switch in an Equipment Rack .....	50
Installing the Switch in a Rack .....	51
Required Items .....	51
Reviewing Safety Precautions .....	51
Installing the PSU into the Switch .....	51
Installing the Switch in a Rack .....	52
<b>Chapter 5: Powering and Starting the Switch .....</b>	<b>55</b>
Powering the Switch .....	56
Powering the Switch .....	56
Starting a Local Management Session .....	58
Powering off the Switch .....	60
<b>Chapter 6: Cabling Networking Ports .....</b>	<b>61</b>
Guidelines for Cabling Network Ports .....	62
Installing Transceivers .....	63
Installing SFP Transceivers .....	63
Installing Direct Attach Cables .....	64
<b>Chapter 7: Troubleshooting .....</b>	<b>65</b>
<b>Appendix A: Technical Specifications .....</b>	<b>69</b>
Physical Specifications .....	70
x980-32CQ Switch .....	70
x980-32DQ Switch .....	70
Ventilation .....	70
Environmental Specifications .....	71
Power Specifications .....	72
Maximum Power Consumptions .....	72
Input Voltage and Frequency .....	72
Heat Dissipation .....	72

# Preface

---

This guide contains the installation instructions for the following switches:

- ❑ x980-32CQ
- ❑ x980-32DQ

In addition to the installation instructions, this guide includes how to build a virtual stack with the Virtual Chassis Stacking (VCStack) feature.

This preface contains the following sections:

- ❑ “Document Conventions” on page 10
- ❑ “Translated Safety Statements” on page 11
- ❑ “Contacting Allied Telesis” on page 12

## Document Conventions

---

This document uses the following conventions:

---

**Note**

Notes provide additional information.

---



---

**Caution**

Cautions inform you that performing or omitting a specific action may result in equipment damage or loss of data.

---



---

**Warning**

Warnings inform you that performing or omitting a specific action may result in bodily injury.

---

## Translated Safety Statements

---

**Important:** The  indicates that translations of the safety statement are available in the PDF document **Translated Safety Statements** posted on the Allied Telesis website at [alliedtelesis.com/library/search](http://alliedtelesis.com/library/search).

- Übersetzte Sicherheitserklärungen

**Wichtig:** Das  zeigt an, dass Übersetzungen der Sicherheitserklärung in den PDF-**Translated Safety Statements** auf der Allied Telesis-Website unter [alliedtelesis.com/us/en/library/search](http://alliedtelesis.com/us/en/library/search) verfügbar sind.

- Declaraciones de seguridad traducidas

**Importante:** El  indica que las traducciones de la declaración de seguridad están disponibles en las **Translated Safety Statements** en PDF publicadas en el sitio web de Allied Telesis en [alliedtelesis.com/us/en/library/search](http://alliedtelesis.com/us/en/library/search).

- Consignes de sécurité traduites

**Important:** Le symbole  indique que les traductions de la déclaration de sécurité sont disponibles dans le PDF **Translated Safety Statements** publiées sur le site Web de Allied Telesis à l'adresse [alliedtelesis.com/us/en/library/search](http://alliedtelesis.com/us/en/library/search).

- Dichiarazioni di sicurezza tradotte

**Importante:**  indica che le traduzioni della dichiarazione di sicurezza sono disponibili nelle **Translated Safety Statements** in PDF pubblicate sul sito Web di Allied Telesis all'indirizzo [alliedtelesis.com/us/en/library/search](http://alliedtelesis.com/us/en/library/search).

- Översatta säkerhetsförklaringar

**Viktig:**  anger att översättningar av säkerhetsförklaringen finns tillgängliga i PDF-dokumentet **Translated Safety Statements** som publicerats på Allied Telesis webbplats på [alliedtelesis.com/us/en/library/search](http://alliedtelesis.com/us/en/library/search).

## **Contacting Allied Telesis**

---

For assistance with this product, contact Allied Telesis technical support at **[www.alliedtelesis.com/support](http://www.alliedtelesis.com/support)**.

## Chapter 1

# Overview

---

The chapter contains the following sections:

- ❑ “Overview” on page 14
- ❑ “Features” on page 16
- ❑ “LEDs” on page 21
- ❑ “Designating Ports in the Command Line Interface” on page 28

# Overview

The x980-32CQ switch featuring 32 QSFP28 slots acts as an enterprise core backbone for hierarchical networks, and it also serves as a private data center switch to connect servers, storage, and other equipment. The x980-32DQ switch with 32 QSFP-DD ports is also designed as a data center solution that offers high performance, efficiency, and flexibility.

Both the x980-32CQ and x980-32DQ switches are Top of Rack (ToR) switches and stackable. Two power supply units (PSUs) in the switch to provide power redundancy.

## x980-32CQ Switch

Figure 1 shows the front panel of the x980-32CQ switch.

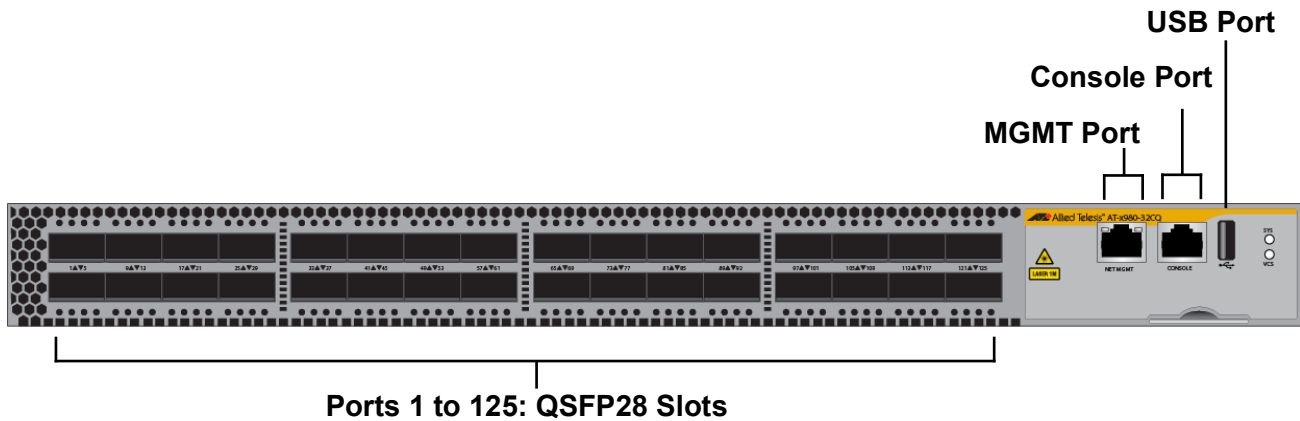

Figure 1. Front Panel of the x980-32CQ Switch

The rear panel of the x980-32CQ switch is shown in Figure 2.

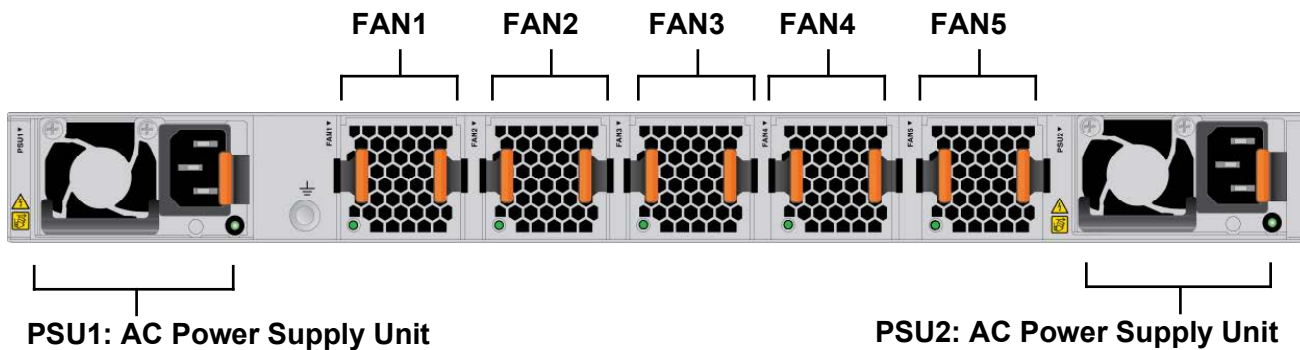

Figure 2. Rear Panel of the x980-32CQ Switch

**x980-32DQ Switch** Figure 3 shows the front panel of the x980-32DQ switch.

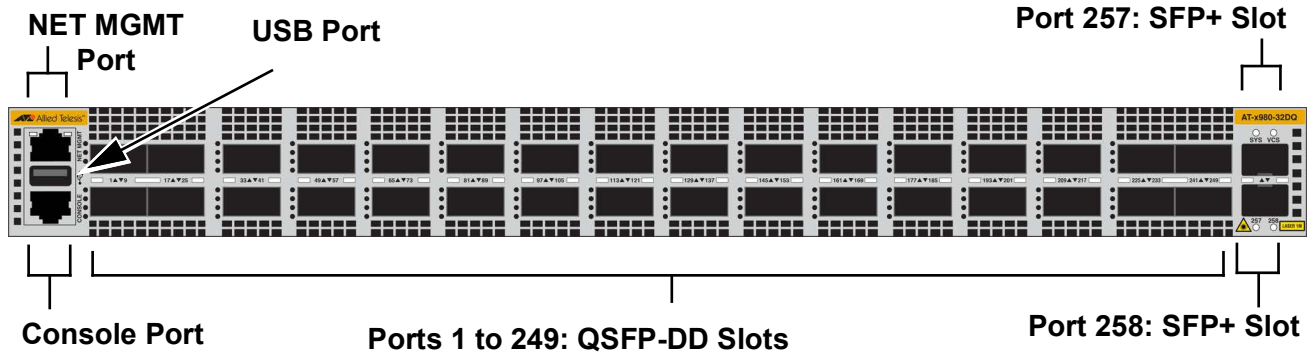

Figure 3. Front Panel of the x980-32DQ Switch

The rear panel of the x980-32DQ switch is shown in Figure 4.

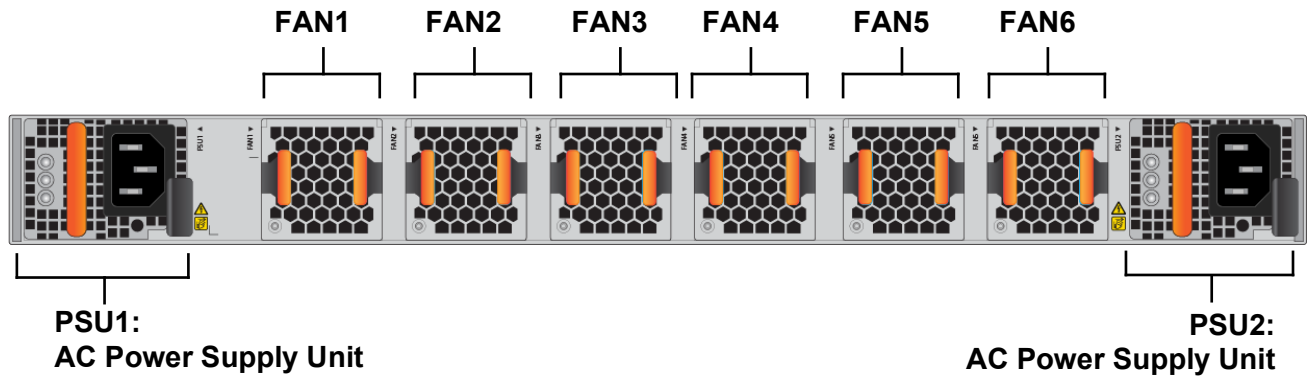

Figure 4. Rear Panel of the x980-32DQ Switch

## Features

---

### **Hardware Features for the x980-32CQ Switch**

The main features of the switch are listed here.

The switch has the following hardware features:

- 32 QSFP28 slots
- MGMT port
- Console port
- USB port
- LEDs
- Two slots for the AT-PWRSYS4 power supply units (PSUs)
- Five AT-FAN17 fan units

### **Hardware Features for the x980-32DQ Switch**

The switch has the following hardware features:

- 32 QSFP-DD slots
- Two SFP+ ports supporting 10Gps
- MGMT port
- Console port
- USB port
- LEDs
- Two slots for the AT-PWRSYS5 power supply units (PSUs)
- Six AT-FAN17 fan units

### **Virtual Chassis Stacking (VCStack)**

The x980-32CQ and x980-32DQ switches feature VCStack, allowing multiple units to act as a single virtual switch.

Here are basic specifications:

- A stack may consist of up to four x980-32CQ switches.
- A stack may consist of up to eight x980-32DQ switches.
- Up to four ports per switch can be configured as stacking ports.

For more information and the instructions to build a virtual stack with the VCStack features, see Chapter 2, “Virtual Chassis Stacking” on page 31.

## SFP Slots

Here are guidelines for transceivers and direct attach cables for the SFP slots:

- ❑ SFP transceivers and direct attach cables are sold separately.
- ❑ For a list of supported transceivers and direct attach cables (DAC), see the product's data sheet at [www.alliedtelesis.com](http://www.alliedtelesis.com).
- ❑ When using a Fiber Optic Small-Form Pluggable (SFP) module, ensure it is IEC 60825-1 certified and Class 1 Laser Product.

## QSFP28 Slots on the x980-32CQ Switch

The x980-32CQ switch comes with 32 QSFP28 ports that support transceivers, direct attach cables (DACs), and breakout cables. The ports support the following:

- ❑ 40Gbps and 100Gbps transceivers
- ❑ Passive or active DACs of the length of 1m, 3m, and 5m
- ❑ Copper and fiber optic breakout cables. A breakout cable allows a single 100G port to be split into four separate 25G connections and a single 40G port into four 10G connections. Figure 5 shows a breakout cable as an example.

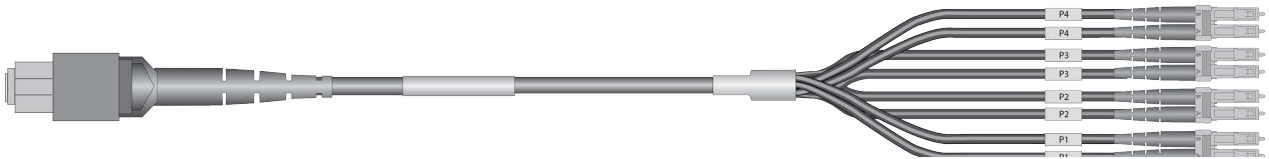

Figure 5. Breakout Cable

## QSFP-DD Slots on the x980-32DQ Switch

The x980-32DQ switch comes with 32 QSFP-DD ports that support the transceivers, direct attach cables (DACs), and breakout cables. The ports support the following:

- ❑ 400Gbps transceivers
- ❑ Passive or active DAC cables of the length of 0.5m, 1m, and 2.5m.
- ❑ Fiber optic breakout cables. A breakout cable allows a single 400G port to be split into eight separate 50G connections. Also, the ports can be split into four separate 100G connections.

## SFP+ Slots on the x980-32DQ Switch

The x980-32DQ switch comes with two SFP + ports. Here are features:

- ❑ The ports support 10G transceivers.
- ❑ The ports support passive and active DAC cables of the length of 0.5m, 1m, and 3m.
- ❑ Not supporting Auto-Negotiation

## NET MGMT Port

The NET MGMT port is an Out of Band (OOB) management port. Here are features:

- ❑ The management port has a standard 8-pin RJ-45 connector and operates at 100Mbps or 1Gbps.
- ❑ The default setting for the port is Auto-Negotiation, which sets the speed and duplex mode automatically. You may disable Auto-Negotiation and configure the port.
- ❑ The port is referred to as eth0 in the management software.

## CONSOLE Port (RS-232)

Use the Console port to conduct local management sessions with the switch. Local management sessions require a terminal or PC with a terminal emulation program, and a management cable. The switch does not need an IP address for local management sessions because they are not conducted over a network. For instructions, refer to “Starting a Local Management Session” on page 58.

## USB Port

You can use the USB port with a flash drive for the following functions:

- ❑ Provide a centralized network backup location for Autonomous Management Framework.
- ❑ Store backup copies of configuration files.
- ❑ Transfer configuration files between switches that are to have similar configurations.
- ❑ Store or transfer log files.
- ❑ Store or transfer debug files (for example, the output of the `SHOW TECH-SUPPORT` command).
- ❑ Boot the AlliedWare Plus operating system and master configuration file from flash drive.
- ❑ Using a flash drive with the switch is optional.

---

### Note

Because the NET MGMT port, USB port, and CONSOLE port are located in close proximity, you can only use two ports at a time if using regular Ethernet cables with resin covers, See Figure 6.

---

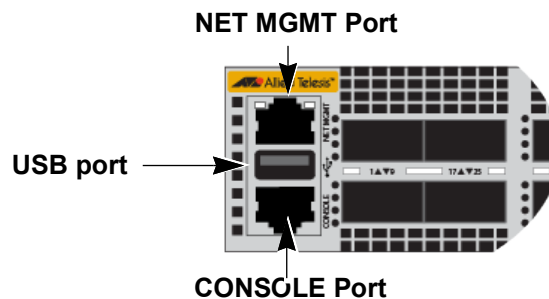

Figure 6. NET MGMT, USB, and CONSOLE ports

## Power Supply Units (PSUs)

The x980-32CQ and x980-32DQ switches can be equipped with two Power Supply Units (PSUs) that supply system power. The two PSUs provide dual redundancy.

See “Power Specifications” on page 72.



### Warning

Power cord is used as a disconnection device. To de-energize equipment, disconnect the power cord. ⚡ E3

Both x980-32CQ and x980-32DQ switches are designed for AC power and do not require grounding; however, the x980-32CQ switch includes a grounding screw and offers optional DC power. See Figure 7. If the x980-32CQ switch is powered via DC, it must be grounded using the ground screw.

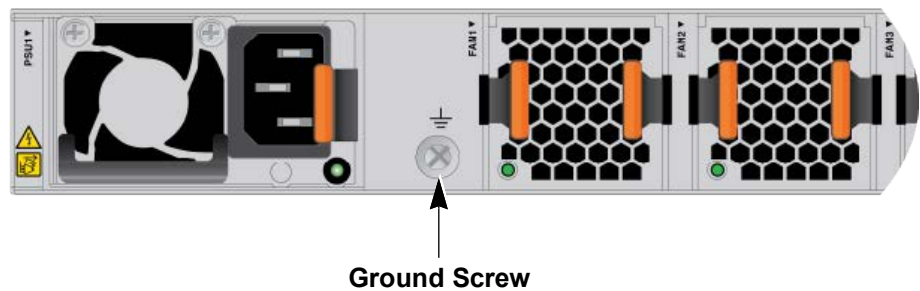

Figure 7. Grounding Screw on the x980-32CQ Switch

## FANs

The x980-32CQ and x980-32DQ switches come with pre-installed AT-FAN17 ventilation fan units. Here are features:

- The x980-32CQ switch comes with five fan units.
- The x980-32DQ switch comes with six fan units.
- One fan unit is allocated as a backup to provide redundancy.
- The airflow direction of the fan is from front to back, drawing air out of the switch.
- The fan units are hot-swappable.

## Label Tag

The x980-32CQ switch has a label tag at the right side of the switch. Pull the tag from the bottom of the switch. The label on the tag indicates the serial number and MAC address of the switch. See Figure 8.

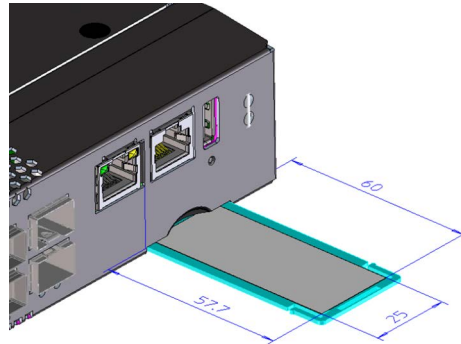

Figure 8. Label Tag

## Management Software and Interfaces

Here are the management software and interfaces:

- AlliedWare Plus™ management software, pre-installed
- Command line interface, available locally through the Console port or remotely via the NET MGMT port.
- SONiC OS is supported.

## Management Methods

You can manage the switch as follows:

- Command line interface accessed locally through the Console port or remotely using SSH.
- Remote management with Vista Manager
- Remote access with SNMPv1, v2c, or v3.

---

### Note

The eco-friendly mode can be turned on or off with the `ECOFRIENDLY LED` or `NO ECOFRIENDLY LED` command in the Command Line Interface.

---

# LEDs

This section describes the LEDs on the switch.

## LEDs for the MGMT, SYS, and VCS ID

The switch has LEDs for the management port, system, and VCS ID information on the front panel. These LEDs are shown in Figure 9 for the x980-32CQ switch and Figure 10 for the x980-32DQ switch. The states of the LEDs are described in Table 1.

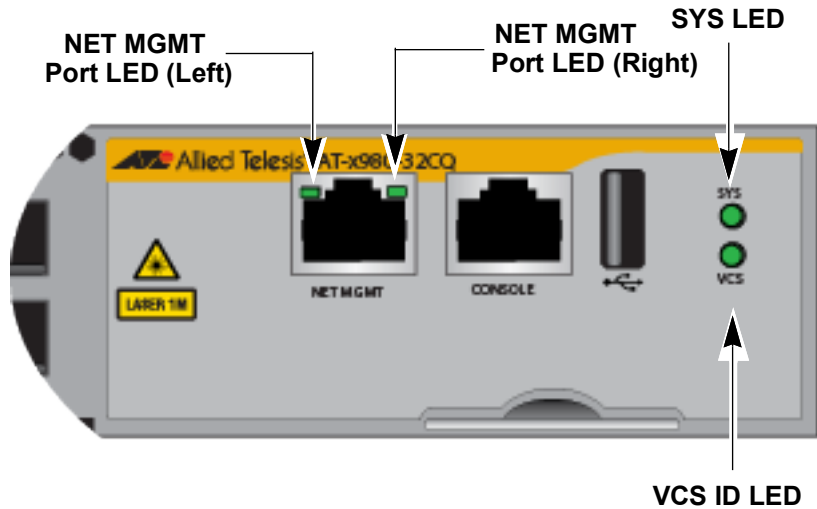

Figure 9. MGMT, SYS, and VCS ID LEDs on the x980-32CQ Switch

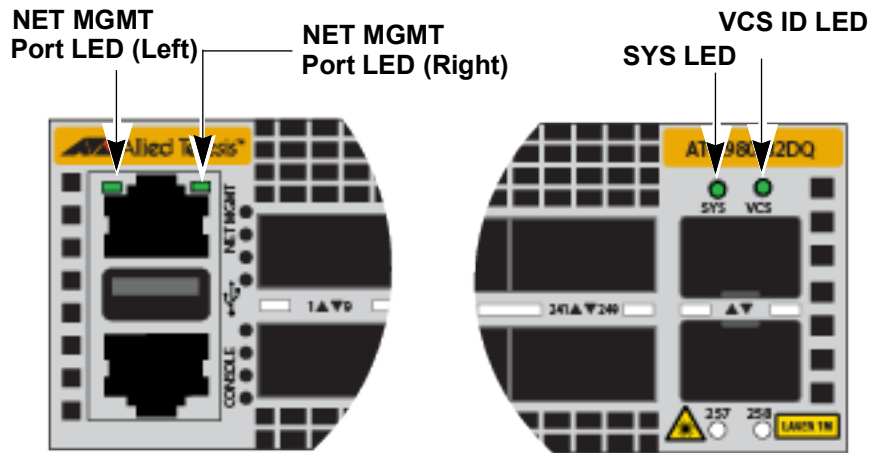

Figure 10. NET MGMT, SYS, and VCS ID LEDs on the x980-32DQ Switch

The LEDs on the MGMT port, system, and VCS ID are described in Table 1.

Table 1. LEDs on the Management Panel

LED		State	Description
SYS		Solid Green	The switch is operating properly.
		Blinking Green	The switch is booting up or having an error. For example, the switch is exceeding the temperature limit.
		Off	The switch is powered off.
VCS		Solid Blue	The switch is a VCS master.
		Solid Yellow	The switch is a VCS member.
		Off	The switch is not in a VCS.
NET MGMT Port	Left	Solid Green	The port is established a link.
		Blinking Green	The port is transmitting or receiving data.
		Off	No link is established.
	Right	Solid Green	The port is operating at 100Mbps or 1Gbps.
		Off	The port is operating at 10Mbps.

**LEDs for QSFP28 Slots**

When a port on the x980-32CQ switch is connected with transceivers or DAC cables, it is a single port; however, the port functions as four ports when using a breakout cable. For example, a breakout cable is connected to port 1, the port functions separately as port *n.0.1*, port *n.0.2*, port *n.0.3*, and port *n.0.4*.

Figure 11 shows the link and activity status LEDs for the QSFP28 slot. For the states of these LEDs, see Table 2 on page 23.

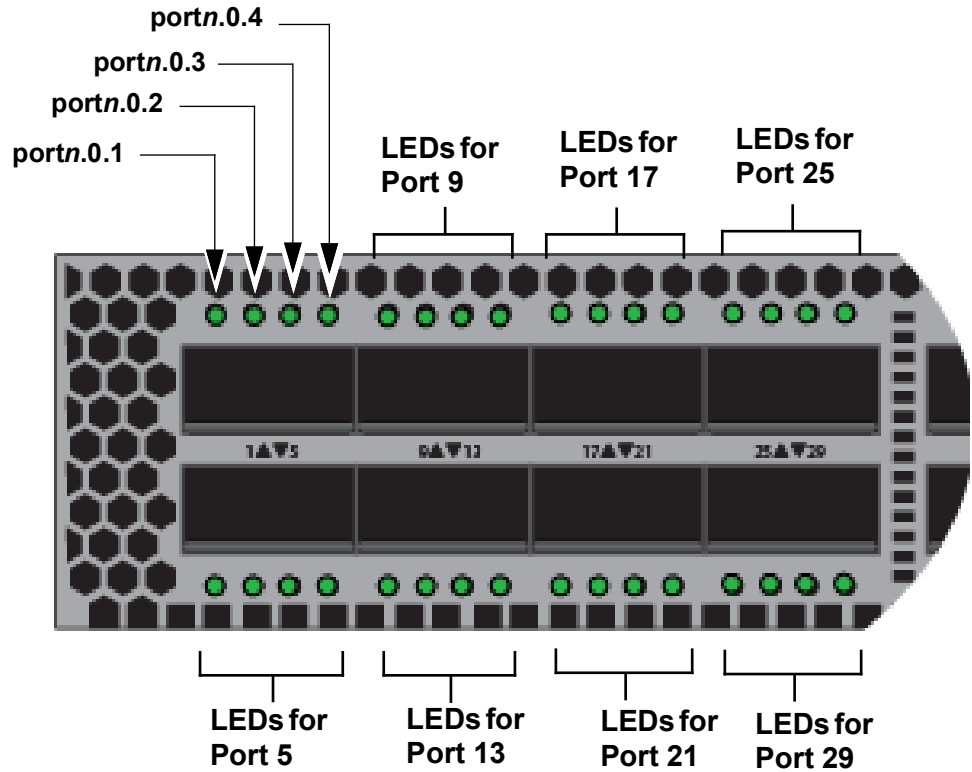

Figure 11. LEDs for Transceiver/DAC/Breakout Cable Slots on x980-32CQ

The states of the LEDs are defined in Table 2.

Table 2. Link and Activity LEDs for QSFP28 Ports

State	Description
Solid Green	The port has established a link to a network device.
Blinking Green	The port is transmitting or receiving data.
Off	Possible causes of this state are: <ul style="list-style-type: none"> <li>- The slot is empty.</li> <li>- The port has not established a link to a network device.</li> <li>- The LEDs are turned off. To turn on the LEDs, use the eco-friendly button in the management panel or the <code>NO ECOFRIENDLY LED</code> command in the command line interface.</li> </ul>

## LEDs for QSFP-DD Slots

The slots for the QSFP-DD transceiver, breakout-capable transceiver, and direct attach copper (DAC) cable have one link and activity status LED for each slot. See Figure 12.

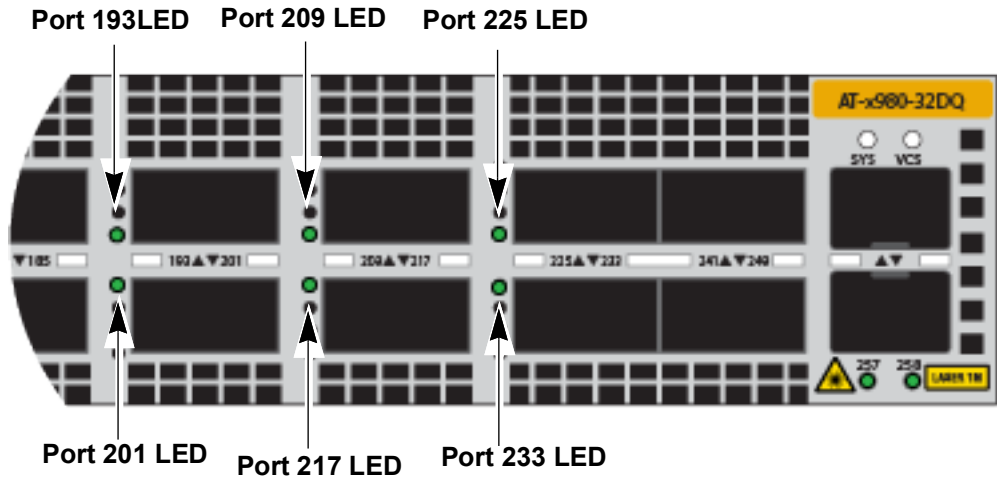

Figure 12. LEDs for QSFP-DD Slots on x980-32DQ

The states of the LEDs are defined in Table 3.

Table 3. Link and Activity LEDs for QSFP-DD Ports

State	Description
Solid Green	The port has established a link to a network device.
Flashing Green	The port is transmitting or receiving data.
Off	Possible causes of this state are listed here: <ul style="list-style-type: none"> <li>- The slot is empty.</li> <li>- The port has not established a link to a network device.</li> <li>- The LEDs are turned off. To turn on the LEDs, use the eco-friendly button in the management panel or the <code>NO ECOFRIENDLY LED</code> command in the command line interface.</li> </ul>

## LEDs for SFP+ Slots

Ports 257 and 258 on the x980-32DQ switch are SFP+ slots that support 10G connection. See Figure 13.

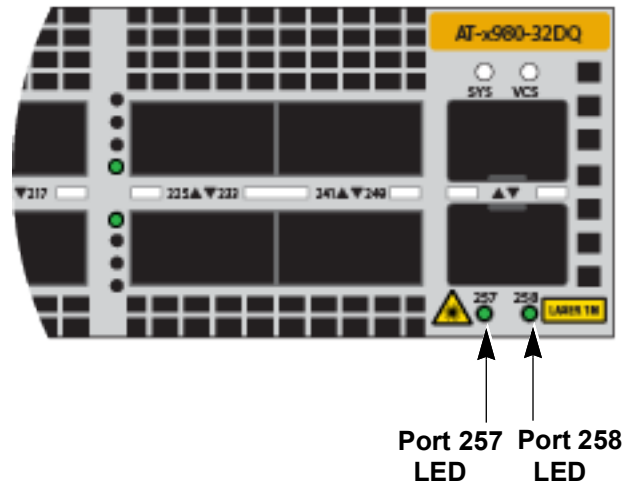

Figure 13. LEDs for SFP+ Slots on x980-32DQ

The states of the LEDs for the SFP+ ports are defined in Table 4.

Table 4. Link and Activity LEDs for SFP+ Ports

State	Description
Solid Green	The port has established a 10Gbps link to a network device.
Flashing Green	The port is transmitting or receiving data at 10Gbps.
Off	Possible causes of this state are listed here: <ul style="list-style-type: none"> <li>- The slot is empty.</li> <li>- The port has not established a link to a network device.</li> <li>- The LEDs are turned off. To turn on the LEDs, use the eco-friendly button in the management panel or the NO ECOFRIENDLY LED command in the command line interface.</li> </ul>

### LEDs for PSUs and Fan Units

Each PSU and fan unit has one LED. Figure 14 shows the locations of LEDs for PSU and fan units on the x980-32CQ switch.

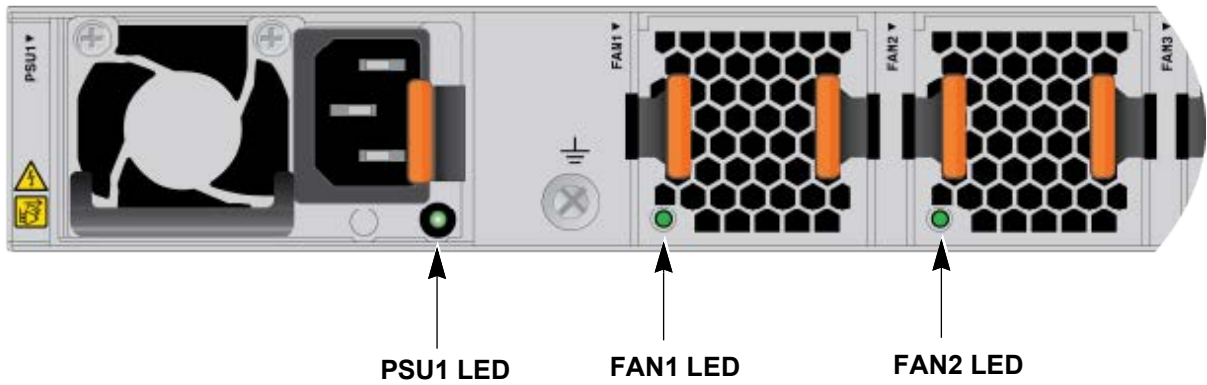

Figure 14. PSU and Fan LEDs on the x980-32CQ Switch

Figure 15 shows the locations of LEDs for PSU and fan units on the x980-32DQ switch.

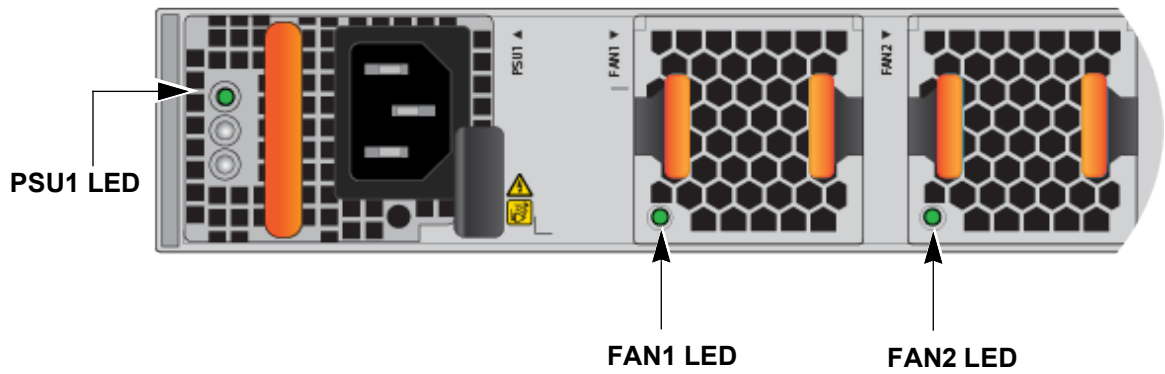

Figure 15. PSU and Fan LEDs on the x980-32DQ Switch

The states of the LEDs are defined in Table 5.

Table 5. LEDs for PSUs and Fan Units

	<b>State</b>	<b>Description</b>
PSU	Solid Green	The PSU is providing power to the switch.
	Flashing Green (One time per second)	The PSU is in standby mode. It indicates that AC power is present and only the 12 VSB (standby voltage) power line is active.
	Blinking Green (Two times per second)	The PSU is providing power, and the firmware is being updated.
	Solid Amber	Possible causes of this state are: <ul style="list-style-type: none"> <li>- The AC cord of the PSU is unplugged or power on one PSU is lost; however, the other PSU is providing power.</li> <li>- The PSU has shut down due to a critical event; failure with Overcurrent Protection (OCP) or Overvoltage Protection (OVP), a fan failure, etc.</li> </ul>
	Flashing Amber (One time per second)	The PSU is operating; however, it is having warning events, such as high temperature, high power, or high current, along with slow fan operation.
	Off	The PSU is not receiving power from an AC source.
Fan	Solid Green	The fan is operating normally.
	Blinking Green (Two times per second)	The fan has failed.
	Off	The fan has no connection to the system.

## Designating Ports in the Command Line Interface

The individual ports on the switch are identified with the PORT parameter in the command line interface of the AlliedWare Plus management software. The format of the parameter is shown in Figure 16.

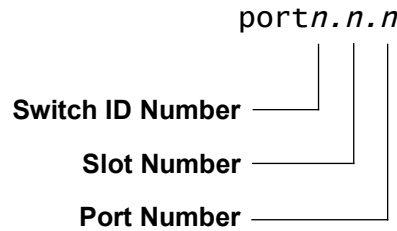

Figure 16. PORT Parameter in the Command Line Interface

The three parts of the PORT parameter are described in Table 6.

Table 6. PORT Parameter Format

Number	Description
Switch ID Number	Identifies the switch’s unique ID number in VCStack.  In the standalone mode, the switch ID number is always 1.
Slot Number	The slot number for the ports on the switch is 0.
Port Number	Identifies a port number.

### Port Number for the x980-32CQ Switch

The port numbering on the x980-32CQ switch is 32 groups of four ports because the ports can be used in the breakout mode. Table 7 shows port numbers when the port is connected with a transceiver/DAC or a breakout cable.

Table 7. Port Numbering for the x980-32CQ Switch

Port Number on the Switch	With Transceiver or DAC	With Breakout Cable
1	portn.0.1	portn.0.1 portn.0.2 portn.0.3 portn.0.4

Table 7. Port Numbering for the x980-32CQ Switch (Continued)

Port Number on the Switch	With Transceiver or DAC	With Breakout Cable
5	portn.0.5	portn.0.5 portn.0.6 portn.0.7 portn.0.8
9	portn.0.9	portn.0.9 portn.0.10 portn.0.11 portn.0.12
13	portn.0.13	portn.0.13 portn.0.14 portn.0.15 portn.0.16

### Port Number for the x980-32DQ Switch

The port numbering on the x980-32DQ switch is 32 groups of eight ports because the ports can be used in the breakout mode. Table 8 shows port numbers when the port is connected with a transceiver/DAC or a breakout cable.

Table 8. Port Numbering for the x980-32DQ Switch

Port Number on the Switch	With Transceiver or DAC	With Breakout Cable
1	portn.0.1	portn.0.1 portn.0.2 portn.0.3 portn.0.4 portn.0.5 portn.0.6 portn.0.7 portn.0.8
9	portn.0.9	portn.0.9 portn.0.10 portn.0.11 portn.0.12 portn.0.13 portn.0.14 portn.0.15 portn.0.16

Table 8. Port Numbering for the x980-32DQ Switch (Continued)

Port Number on the Switch	With Transceiver or DAC	With Breakout Cable
17	portn.0.17	portn.0.17 portn.0.18 portn.0.19 portn.0.20 portn.0.21 portn.0.22 portn.0.23 portn.0.24
25	portn.0.25	portn.0.25 portn.0.26 portn.0.27 portn.0.28 portn.0.29 portn.0.30 portn.0.31 portn.0.32

## Examples for the PORT Parameters

Here are examples of the PORT parameter in the INTERFACE command for switches in a stack.

The first example enters the port Interface mode for port 11 in a switch with ID 1:

```
awplus> enable
awplus# configure terminal
awplus(config)# interface port1.0.11
```

This example enters the port Interface mode for port 4 to 7 in a switch with ID 2:

```
awplus(config)# interface port2.0.4-2.0.7
```

---

### Note

You must include the PORT parameter when identifying individual ports and omit it from the last port when specifying ranges.

---

This example enters port Interface mode for port 10 in a switch with ID 1 and port 18 in a switch with ID 2:

```
awplus(config)# interface port1.0.10,port2.0.18
```

## Chapter 2

# Virtual Chassis Stacking

---

The sections in this chapter are listed here:

- “Overview” on page 32
- “Stacking Guidelines” on page 33
- “Stacking Ports Examples” on page 35
- “Master and Member Switches” on page 37
- “Optional Feature Licenses” on page 38

## Overview

---

The Virtual Chassis Stacking (VCStack) feature enables you to link together x980-32CQ and x980-32DQ switches into a virtual stack so that they function as a single networking unit.

The feature provides the following benefits:

- ❑ Simplifies management - You can manage the devices as a single unit, rather than individually. Your local and remote management sessions automatically give you management access to all the switches.
- ❑ Reduces IP addresses - A stack requires only one IP address for remote management access, reducing the number of IP addresses you have to assign to network devices. The one address gives you management access to all the stack units.
- ❑ Adds feature flexibility and resiliency - Stacking gives you more flexibility in how you can configure some features. For instance, you can create port aggregations using ports from different switches, rather than ports from only one switch. By distributing the ports of an aggregation across multiple switches, you increase its resiliency because the aggregation can continue to function, though at a reduced bandwidth, even if a switch in a stack stops functioning.

## Stacking Guidelines

---

Before configuring a stack, read the guidelines here.

### General Stacking Guidelines

Here are general stacking guidelines:

- ❑ A stack may consist of up to four x980-32CQ switches.
- ❑ A stack may consist of up to eight x980-32DQ switches.
- ❑ A stack must consist of the same switch models.
- ❑ The VCStack feature on the x980-32CQ and x980-32DQ switch is enabled by default. Disabling or enabling VCStack requires rebooting the switch.
- ❑ The switches must have the same optional features licenses. If you purchased optional features for the switches, you should install them before assembling the stack.
- ❑ You should *not* pre-configure the features of the switches, such as VLANs and spanning tree, before building the stack. The configuration settings are likely to be discarded once the switches begin operating as a stack.
- ❑ If a stack fails for any reason, the switches operate as stand-alone devices.

### Stacking Port Guidelines

The switches of a stack are connected with stacking ports. Here are guidelines for a stack and stacking ports:

- ❑ Up to four ports per switch can be stacking ports.
- ❑ You can choose any ports as stacking ports; however, they must operate at the same bandwidth.
- ❑ As stacking ports, QSFP28 ports on the x980-32CQ switch must be configured as 100Gbps.
- ❑ As stacking ports, QSFP-DD ports on the x980-32DQ switch must be configured for 400Gbps.
- ❑ Once ports are designated as stacking ports, they cannot be used as regular network ports.
- ❑ To designate stacking ports with the `STACKPORT` command. To remove the stacking port function from ports, use the `NO STACKPORT` command in the AlliedWare Plus operating system.

- ❑ The fiber optic transceivers or direct attach cables (DACs) for stacking ports must be from Allied Telesis. Transceivers or cables from other network equipment providers might not perform properly as stacking ports. For a list of supported transceivers and direct attach cables, visit the Allied Telesis web site at [www.alliedtelesis.com](http://www.alliedtelesis.com).
- ❑ The cables for stacking ports must all be of the same type: all fiber optic cables or DACs.
- ❑ Allied Telesis recommends using the same ports on the switches in a stack and connecting together the same ports in the switches, if possible. This practice makes managing or troubleshooting a stack easier.
- ❑ Allied Telesis recommends choosing consecutive ports. This practice makes managing or troubleshooting a stack easier.

## Stacking Ports Examples

---

This section shows examples of stacking for two switches with two stacking ports and for four switches with four stacking ports.

### VCStack with Two Switches and Two Ports

Figure 17 shows an example of VCStack with two x980-32CQ switches with ports 1 and 5 as stacking ports. Here are the general properties for this example:

- ❑ The stack consists of two switches of the x980-32CQ model, and each switch uses two ports as stacking ports.
- ❑ The cables for stacking ports are all fiber optic cables.
- ❑ Each port on the x980-32CQ switch is configured at 100Gbps.

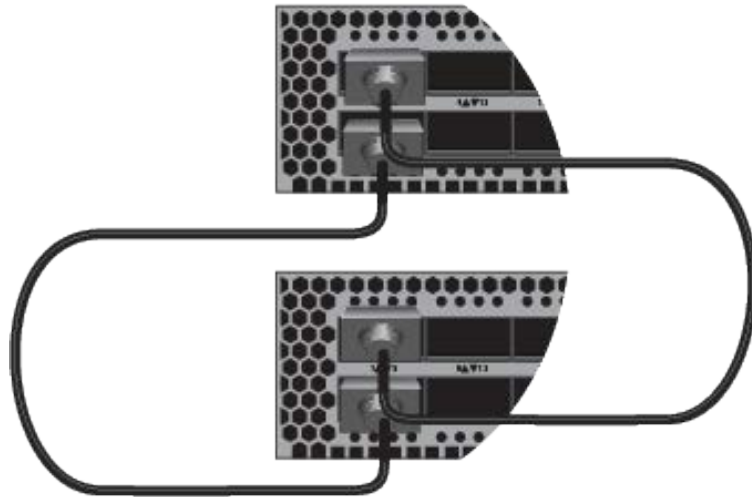

Figure 17. Stack Examples with Two x980-32CQ Switches and Two Ports

### VCStack with Four Switches and Four Ports

Another example of VCS stack is shown in Figure 18 on page 36 using the x980-32CQ switches. Here are the general properties for this example:

- ❑ The stack consists of four switches, and each switch uses four ports as stacking ports.
- ❑ The cables in a stack must all be of the same type: all fiber optic cables.
- ❑ Each port on the x980-32CQ switch is configured at 100Gbps.
- ❑ The switches use the same consecutive ports 1, 5, 9, and 13.

---

#### Note

The stacking ports do not have to be consecutive, nor do they have to be the same ports on the four switches. But following the recommendations can make stack management easier.

---

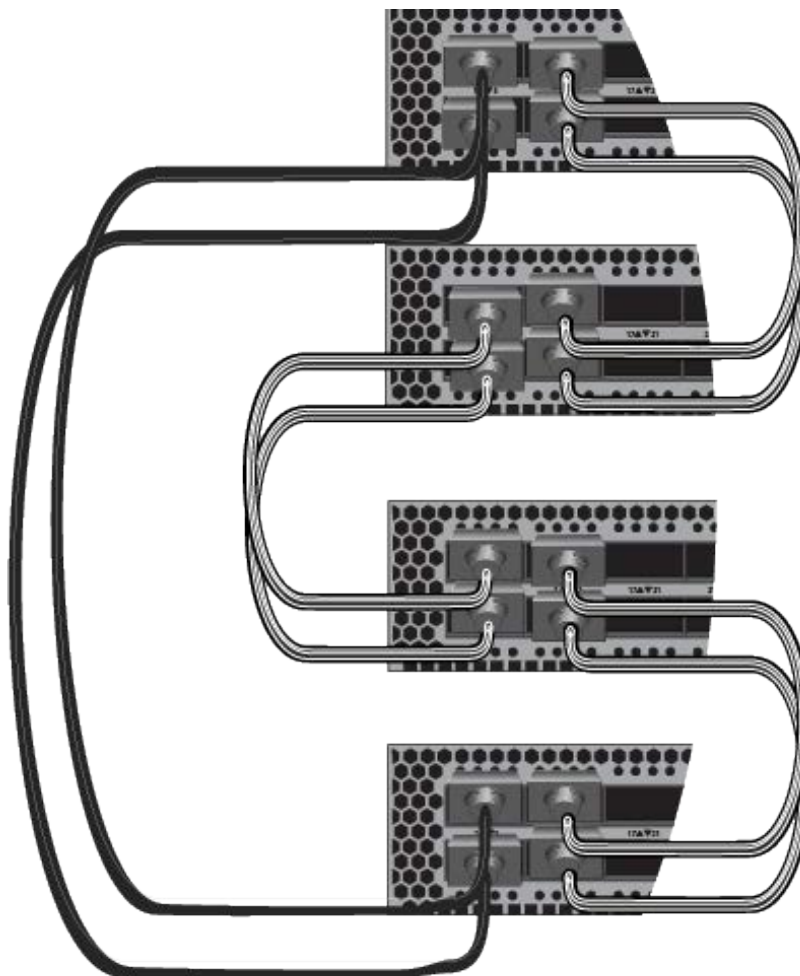

Figure 18. Example Stack of Four x980-32CQ Switches and Four Ports

## Master and Member Switches

---

One switch of a stack functions as a master switch. Its main functions are listed here:

- ❑ Coordinate and monitor stack operations.
- ❑ Verify that the switches are using the same version of management software. It automatically downloads its management software over the stacking cables to switches with different software versions.
- ❑ Verify that the switches have different ID numbers. It automatically assigns new ID numbers to resolve conflicts where two switches have the same ID number.

The other switches are called member switches.

### Selection of the Master Switch

The switches of the stack designate the master switch during the initialization process, when they are powered on or reset. They base the selection of the master switch on the following parameters:

- ❑ Stack priority numbers
- ❑ MAC addresses

The stack priority number is an adjustable value of 0 to 255, where the lower the number, the higher the priority. Typically, the switch with the lowest priority number (highest priority) becomes the master switch of a stack. The default priority value is 128.

If the switches have the same priority values, the selection of the master switch is based on their MAC addresses. As with the priority value, the lower the MAC address, the higher the priority. The switch with the lowest MAC address becomes the master switch.

If you power on the stack without adjusting the priority values, the master switch is selected based on the MAC addresses if the units are powered on simultaneously. If you power on the switches one at a time, the master switch is the first switch powered on.

## Optional Feature Licenses

---

The x980-32CQ and x980-32DQ switches come with the AlliedWare Plus management software and a base set of features that are available as soon as you install the device. Additional features and capabilities might be included with the operating system but can be access only after they are unlocked with optional feature licenses from Allied Telesis. Contact your authorized reseller or distributor for a list of optional features licenses for this product.

Here are the guidelines to feature licenses for a stack of the x980-32CQ and x980-32DQ switches:

- ❑ The VCStack feature is part of the base features of the switch. It does not require an optional feature license.
- ❑ You can install feature licenses while the switches are operating as stand-alone units or as a stack.
- ❑ When ordering feature licenses for the switches of a stack, you must order one license for each switch.
- ❑ Switches can form a stack even if they have different feature licenses; however, the additional features are only available on those switches with the licenses. The stack generates a warning message if it detects that the switches do not have the same optional feature licenses.

## Chapter 3

# Beginning the Installation

---

The chapter contains the following sections:

- “Reviewing Safety Precautions” on page 40
- “Choosing a Site for the Chassis” on page 44
- “Unpacking the Boxes and Verifying the Contents” on page 45
- “Installation Options and Instructions” on page 47

## Reviewing Safety Precautions

---

Please review the following safety precautions before beginning the installation procedure.

---

### Note

Safety statements that have the  symbol are translated into multiple languages in the *Translated Safety Statements* document at [www.alliedtelesis.com/support](http://www.alliedtelesis.com/support).

---



---

### Warning

Class 1 Laser product.  L1

---



---

### Warning

Laser Radiation.  
Class 1M Laser product.

---



---

### Warning

Do not stare into the laser beam.  L2

---



---

### Warning

Do not look directly at the fiber optic ends or inspect the cable ends with an optical lens.  L6

---



---

### Warning

Laser Safety: EN60825-1.  L7

---



---

### Warning

To prevent electric shock, do not remove the cover. No user-serviceable parts inside. This unit contains hazardous voltages and should only be opened by a trained and qualified technician. To avoid the possibility of electric shock, disconnect electric power to the product before connecting or disconnecting the LAN cables.

 E1

---

**Warning**

This unit has more than one power input. To reduce the risk of electric shock, disconnect all power inputs before servicing the unit.

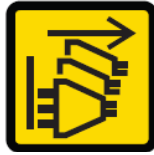
**Warning**

Do not work on equipment or cables during periods of lightning activity. ⚡ E2

**Warning**

Power cord is used as a disconnection device. To de-energize equipment, disconnect the power cord. ⚡ E3

**Warning**

Class I Equipment. This equipment must be earthed. The power plug must be connected to a properly wired earth ground socket outlet. An improperly wired socket outlet could place hazardous voltages on accessible metal parts. ⚡ E4

---

**Note**

Pluggable Equipment. The socket outlet shall be installed near the equipment and shall be easily accessible. ⚡ E5

**Caution**

Air vents must not be blocked and must have free access to the room ambient air for cooling. ⚡ E6

**Warning**

Operating Temperatures. This product is designed for a maximum ambient temperature of 40° degrees C. ⚡ E52

---

**Note**

All Countries: Install product in accordance with local and National Electrical Codes. ⚡ E8

---



**Warning**

Only trained and qualified personnel are allowed to install or replace this equipment. *↪* E14

---



**Caution**

Circuit Overloading: Consideration should be given to the connection of the equipment to the supply circuit and the effect that overloading of circuits might have on overcurrent protection and supply wiring. Appropriate consideration of equipment nameplate ratings should be used when addressing this concern. *↪* E21

---



**Caution**

Risk of explosion if battery is replaced by an incorrect type. Replace only with the same or equivalent type recommended by the manufacturer. Dispose of used batteries according to the manufacturer's instructions.

**Attention:** Le remplacement de la batterie par une batterie de type incorrect peut provoquer un danger d'explosion. La remplacer uniquement par une batterie du même type ou de type équivalent recommandée par le constructeur. Les batteries doivent être éliminées conformément aux instructions du constructeur. *↪* E22

---



**Warning**

Mounting of the equipment in the rack should be such that a hazardous condition is not created due to uneven mechanical loading. *↪* E25

---

---

**Note**

Use dedicated power circuits or power conditioners to supply reliable electrical power to the device. *↪* E27

---

---

**Note**

If installed in a closed or multi-unit rack assembly, the operating ambient temperature of the rack environment may be greater than the room ambient temperature. Therefore, consideration should be given to installing the equipment in an environment compatible with the manufacturer's maximum rated ambient temperature (T<sub>mra</sub>).

*↪* E35

---

**Caution**

Installation of the equipment in a rack should be such that the amount of air flow required for safe operation of the equipment is not compromised.  E36

---

**Warning**

Reliable earthing of rack-mounted equipment should be maintained. Particular attention should be given to supply connections other than direct connections to the branch circuits (e.g., use of power strips).  E37

---

**Warning**

This equipment shall be installed in a Restricted Access location.  E45

---

**Caution**

The unit does not contain serviceable components. Please return damaged units for servicing.  E42

---

**Warning**

The temperature of an operational SFP, SFP+, SFP28, QSFP+ or QSFP28 transceiver may exceed 70° C (158° F). Exercise caution when removing or handling transceivers with unprotected hands.

---

**Warning**

Switches should not be stacked on top of one another on a table or desktop because that could present a personal safety hazard if you need to move or replace switches.  E91

---

**Warning**

The device is heavy. Always ask for assistance when moving or lifting it to avoid injuring yourself or damaging the equipment.  E122

---

**Warning**

This unit has more than one power input. To reduce the risk of electric shock, disconnect all power inputs before servicing unit.

---

## Choosing a Site for the Chassis

---

Observe these site requirements.

- ❑ Check that the rack that you plan to install the switch is safely secured.
- ❑ The power outlet should be located near the chassis and be easily accessible.
- ❑ The site should allow for easy access to the ports on the front of the switch, so that you can easily connect and disconnect cables, and view the port LEDs.
- ❑ The site should allow for adequate air flow around the unit and through the cooling vents on the front and rear panels. The ventilation direction is from front to back, with the fans on the back panel drawing the air out of the unit.
- ❑ The site should not expose the switch to moisture or water.
- ❑ The site should be a dust-free environment.
- ❑ The site should include dedicated power circuits or power conditioners to supply reliable electrical power to the network devices.
- ❑ Switch ports are suitable for intra-building connections, or where non-exposed cabling is required.
- ❑ Do not install the device in a wiring or utility box that has inadequate airflow because it might overheat and fail.

## Unpacking the Boxes and Verifying the Contents

The first step to install the switch is to unpack the shipping box. Here are the guidelines:



### Warning

The device is heavy. Always ask for assistance before moving or lifting it to avoid injuring yourself or damage the equipment. *E122*

- ❑ If any item is missing or damaged, contact your Allied Telesis sales representative for assistance.
- ❑ Store the packaging material in a safe location. Use the original shipping material if you need to return the device to Allied Telesis.





Unpack the boxes and remove the switch. Verify and inspect the contents. Table 9 shows the contents of the accessory kit.

Table 9. Accessory Kit

Item	Contents	
	x980-32CQ	x980-32DQ
Rack Bracket Kit: <ul style="list-style-type: none"> <li>❑ Two Front Rails</li> <li>❑ Two Rear Rails</li> <li>❑ 28 M4 Screws</li> </ul>		
Fan Units (Pre-installed)	<p>Five Fan Units</p>	<p>Six Fan Units</p>

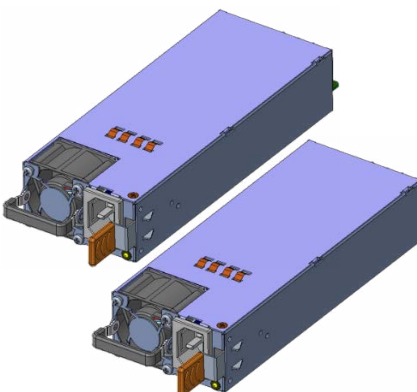
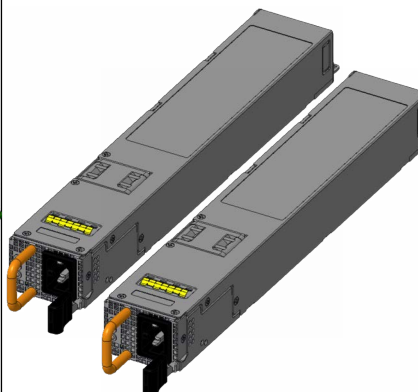
Table 10 shows the items of the PSU package.

Table 10. PSU Package

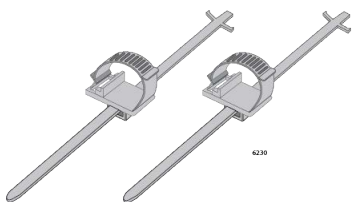
Item	Contents	
	x980-32CQ	x980-32DQ
Two AC Power Supply Units	 <p>AT-PWRSYS4 PSUs</p>	 <p>AT-PWRSYS5 PSUs</p>
Two Power Cords	 <p>1570</p>	 <p>1570</p>
Retainers	 <p>Two self-grip straps</p>	 <p>6230</p> <p>Two sets of retainer clamps and cable ties</p>

## Installation Options and Instructions

The Installation options of the x980-32CQ and x980-32DQ switches are shown in Table 11.

Table 11. Installation Options

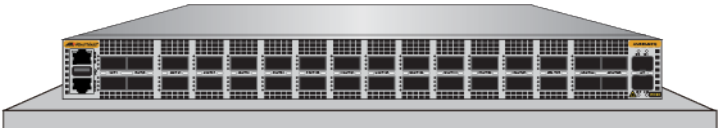
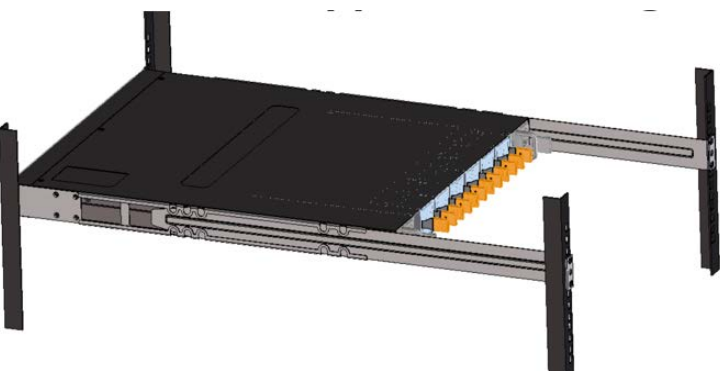
<b>x980-32CQ and x980-32DQ</b>	
Tabletop	 <p>The switch's bottom must face the tabletop.</p>
19-inch Equipment Rack	 <p>The switch's bottom must face down.</p>
Wall	Wall mounting is not supported.

To install the switch on an equipment rack, go to Chapter 4, “Installing the Switch in an Equipment Rack” on page 49.



## Chapter 4

# Installing the Switch in an Equipment Rack

---

This chapter contains instructions for installing the switch in a standard 19-inch equipment rack. The procedures in this chapter are:

- “Overview of Installing the Switch in an Equipment Rack” on page 50
- “Installing the Switch in a Rack” on page 51

## Overview of Installing the Switch in an Equipment Rack

---

The x980-32CQ and x980-32DQ switches can be installed in a 19-inch equipment rack with the brackets that come with the switch.

Here are guidelines for installing the switch on an equipment rack:

- ❑ Before installing the switch, review the information and perform the procedures in Chapter 3, “Beginning the Installation” on page 39.
- ❑ The switch must be installed to the equipment rack with two front posts and two back posts, as shown in Figure 19.
- ❑ Use two pairs of front and rear brackets that come with the switch.
- ❑ Install the switch with its front panel flush with the front of the equipment rack.



Figure 19. Switch Installed in Four-posts Rack Rail

## Installing the Switch in a Rack

---

When installing the switch in a 19-inch equipment rack, use the brackets that come with the switch.

### Required Items

The following items are required to install the switch in an equipment rack:

- Two pairs of front and rear rail brackets (includes with the switch)
- 28 M4 bracket screws (included with the switch)
- Eight rack fixed thumb screws, such as M5, M6, 10#-32, or 12#-24 (not provided).



- Eight rack fixed cage nuts, such as M5, M6, 10#-32, or 12#-24 (not provided).

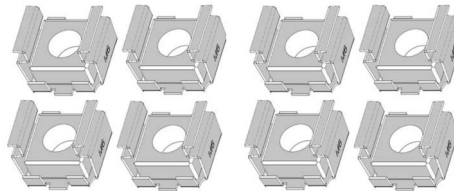

- Cross-head screwdriver (not provided)

### Reviewing Safety Precautions

Before installing PSUs into the switch and the unit in a rack, review the following information:

- “Reviewing Safety Precautions” on page 40
- “Choosing a Site for the Chassis” on page 44.



#### Caution

The chassis may be heavy and awkward to lift. Allied Telesis recommends that you get assistance when mounting the chassis in an equipment rack. *E28*

---

### Installing the PSU into the Switch

If the PSUs are not installed in your switch, install them into the switch before installing the switch in an equipment rack.

To install the PSUs into the switch:

1. Place the switch on a level, secure surface, facing the rear panel toward you.

2. For the x980-32CQ switch, remove both blank panels covering the PSU1 and PSU2 slots on the rear panel.

Skip this step for the x980-32DQ switch.

3. Carefully align a PSU in the PSU1 slot and slide it into the slot.
4. When the PSU makes contact with the connector inside the switch, gently press its handle to seat it.
5. Repeat Step 3 and Step 4 to install the second PSU into the PSU2 slot.

## Installing the Switch in a Rack

To install the switch in a 19-inch equipment rack:

1. Review “Reviewing Safety Precautions” on page 40 and “Choosing a Site for the Chassis” on page 44.



### Caution

The chassis may be heavy and awkward to lift. Allied Telesis recommends that you get assistance when mounting the chassis in an equipment rack. ⚡ E28

2. Place the switch on a level, secure surface.
3. Attach the front rail brackets to the sides of the switch with the 28 M4 screws as shown in Figure 20 on page 52.

Tighten the 28 screws to attach the front rail brackets to the switch.

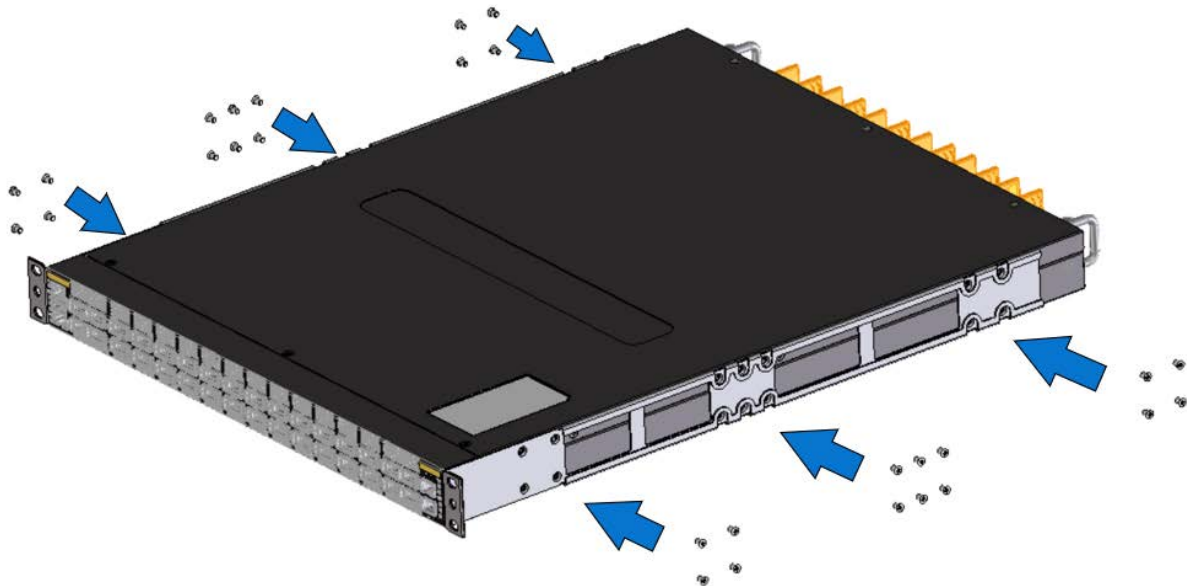

Figure 20. Attaching the Front Rail Brackets to the Switch

4. Align the switch unit to the front rack poles from the front of the rack as shown in Figure 21.

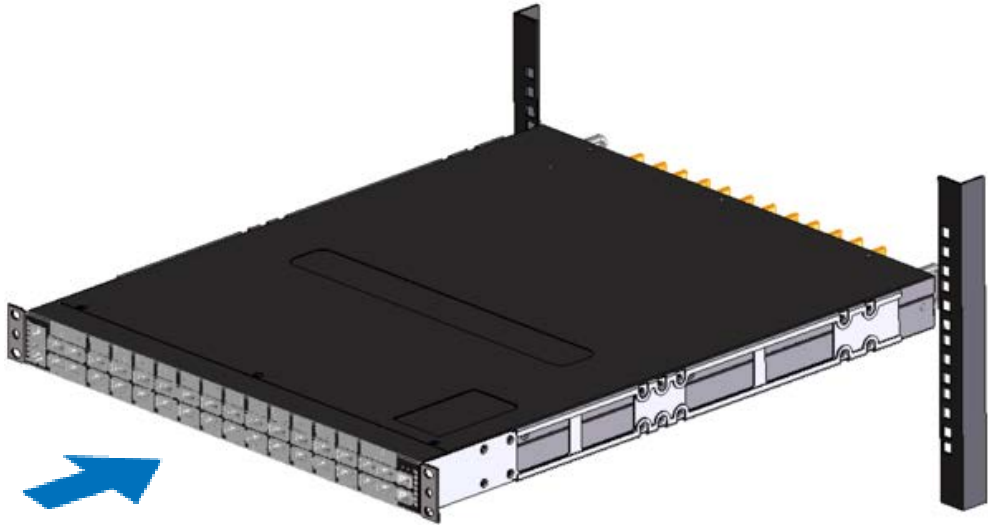

Figure 21. Aligning the Switch Unit to the Front Rack Poles

5. Install the switch unit to the front rack poles by tightening the thumb screws. See Figure 22 on page 53.

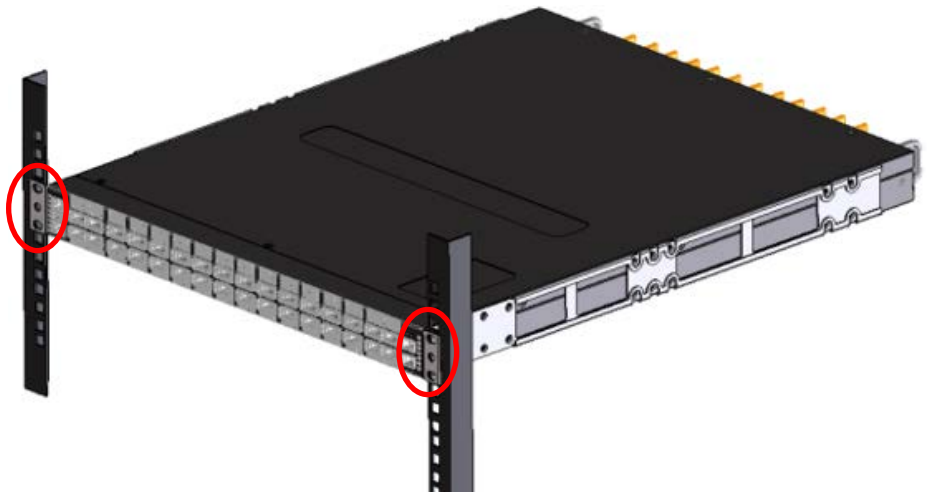

Figure 22. Installing the Switch to the Front Rack Poles

6. Insert the rear rack brackets to the front rack brackets attached to the sides of the switch and align the rear rack brackets to the rear rack poles. See Figure 23.

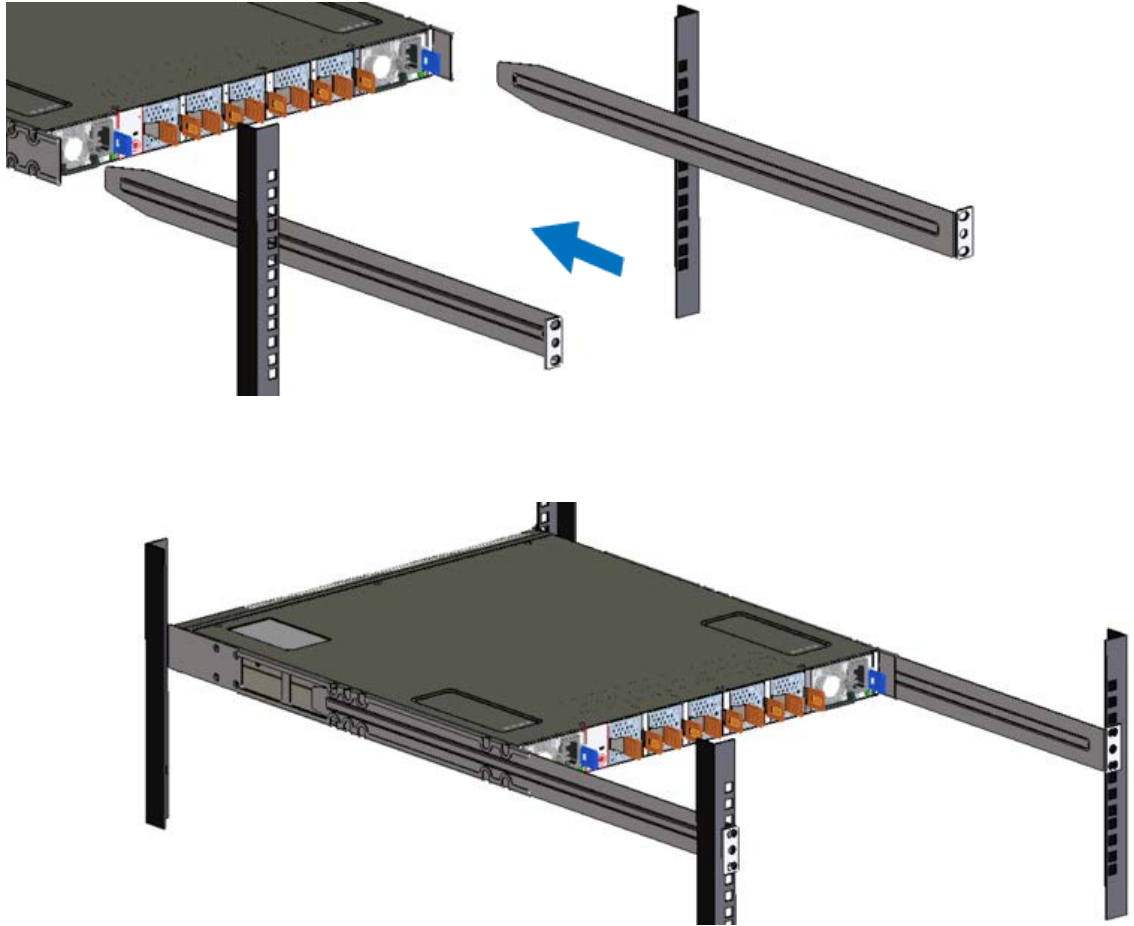

Figure 23. Aligning the Rear Rack Brackets to the Rear Rack Poles

7. Attach the rear rack brackets to the rear rack poles using the thumb screws. See Figure 24.

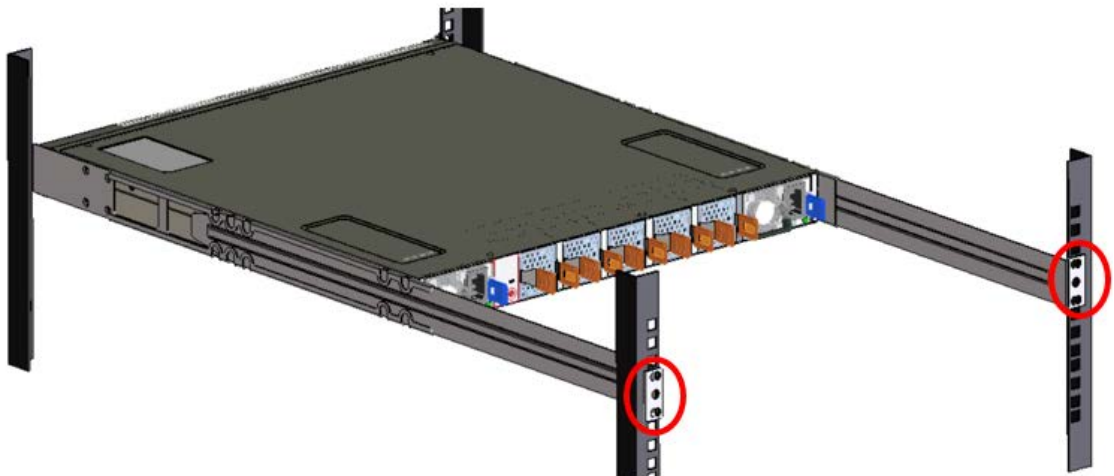

Figure 24. Attaching the Rear Rack Brackets to the Rear Rack Poles

## Chapter 5

# Powering and Starting the Switch

---

This chapter contains the following sections:

- “Powering the Switch” on page 56
- “Starting a Local Management Session” on page 58
- “Powering off the Switch” on page 60

## Powering the Switch

---

The x980-32CQ and x980-32DQ switches are designed to work with two Power Supply Units (PSUs) to provide power redundancy. Each power unit is capable of powering the entire switch. One PSU is active and providing power, while the other PSU is in the standby mode and ready to take over when the active PSU fails.

### Powering the Switch

To power the switch:

1. Review the following information:
  - “Reviewing Safety Precautions” on page 40
  - “Power Specifications” on page 72.



#### Warning

Power cord is used as a disconnection device. To de-energize equipment, disconnect the power cord. *GS* E3

---

#### Note

Pluggable Equipment. The socket outlet shall be installed near the equipment and shall be easily accessible. *GS* E5

---

2. Plug in a power cord to a PSU.
3. Secure the power cord to the PSU unit.

For the x980-32CQ switch, secure the power cord with the self-grip strap that comes with the PSU unit. See Figure 25.

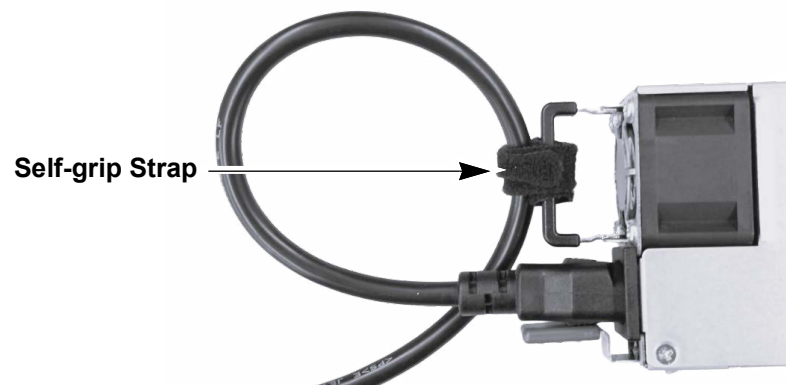

Figure 25. Securing Power Cord with Self-grip Strap for the x980-32CQ Switch

For the x980-32DQ switch, secure the power cord with the retainer clamp and a cable tie that come with the PSU unit. See Figure 26.

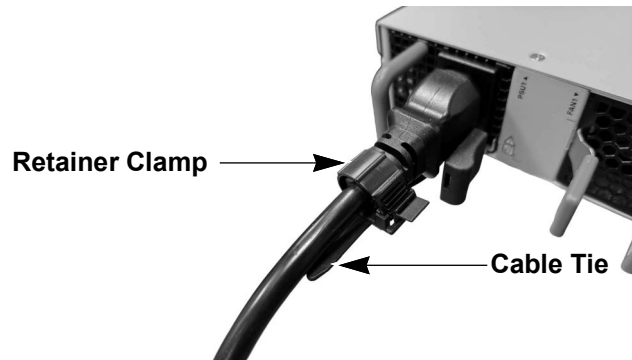

Figure 26. Securing Power Cord with Retainer Clamp and Cable tie for the x980-32DQ Switch

4. Connect the power cord to an appropriate AC power source.
5. Repeat Step 2 to Step 4 for the second PSU.
6. Go to “Starting a Local Management Session” on page 58.

## Starting a Local Management Session

---

This procedure explains how to start a local management session on the switch. It assumes that you powered the device and waited two minutes for it to initialize its operating software.

---

**Note**

The first management session of the switch can be either a local session, as explained in this section, or a remote session. For remote management, the switch uses either its default IP address 192.168.42.42 or an address assigned to it by a DHCP server. For instructions on how to start a remote management session, visit <https://www.alliedtelesis.com>.

---

To start a local management session:

1. Connect the RJ-45 end of the management cable to the Console RS-232 port on the management panel.
2. Connect the other end of the cable to an RS-232 port on a terminal or personal computer with a terminal emulation program.
3. Configure the VT-100 terminal or terminal emulation program as follows:
  - Baud rate: 9600 bps
  - Data bits: 8
  - Parity: None
  - Stop bits: 1
  - Flow controller: None

---

**Note**

The port settings are for a DEC VT100 or ANSI terminal, or an equivalent terminal emulator program.

---

4. Press Enter.

You are prompted for a username and password.

5. Enter the default username and password:
  - Username: manager
  - Password: friend

---

**Note**

Username and passwords are case sensitive.

---

The local management session starts when the User Exec mode prompt, shown in Figure 27, is displayed.

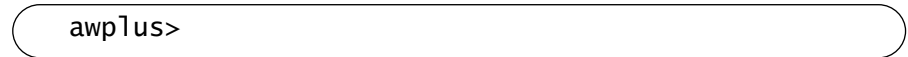
A rounded rectangular box containing the text 'awp1us>' which represents the User Exec mode prompt on a switch.

```
awp1us>
```

Figure 27. User Exec Mode Prompt

---

**Note**

To configure the switch, visit <https://www.alliedtelesis.com> for more information.

---

## Powering off the Switch

---

To power off the switch, perform the following procedure:

1. Unplug the power cord as shown in Figure 28.

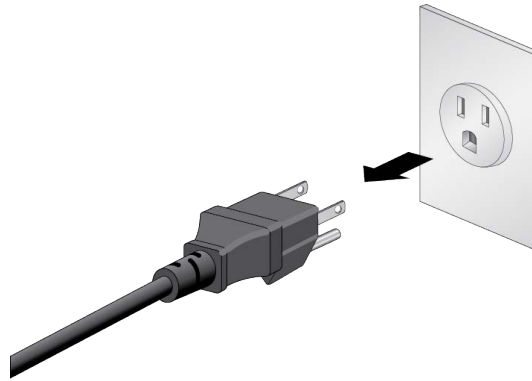

Figure 28. Powering Off the AC Power Supply

2. Unplug the other power cord.

## Chapter 6

# Cabling Networking Ports

---

This chapter contains the following procedures:

- ❑ “Guidelines for Cabling Network Ports” on page 62
- ❑ “Installing Transceivers” on page 63
- ❑ “Installing Direct Attach Cables” on page 64

## Guidelines for Cabling Network Ports

---

Review the following guidelines before installing transceivers/direct attach cables to the ports:



---

**Warning**

Laser Safety: EN60825-1. ⚡ L7

---



---

**Caution**

Transceivers can be damaged by static electricity. Be sure to observe all standard electrostatic discharge (ESD) precautions, such as wearing an antistatic wrist strap, to avoid damaging the devices. ⚡ E92

---

- ❑ QSFP28 and QSFP-DD transceivers/direct attach cables are hot-swappable. You can install them while the switch is powered on.

---

**Note**

For a list of supported transceivers and direct attach cables, refer to the product data sheet on the Allied Telesis web site at [www.alliedtelesis.com](http://www.alliedtelesis.com).

---

- ❑ The ports for QSFP28 support 40Gbps and 100Gbps transceivers and direct attach cables.
- ❑ The ports for QSFP-DD support 400Gbps transceivers and direct attach cables.
- ❑ You may install a transceiver before connecting the fiber optic cable.
- ❑ Fiber optic transceivers are dust sensitive. Always keep the plug in the optical bores when a fiber optic cable is not installed, or when you store the transceiver. When you do remove the plug, keep it for future use.
- ❑ Unnecessary removal and insertion of a transceiver or direct attach cable can lead to premature failure.

## Installing Transceivers

---

This section contains instructions for installing transceivers in the ports on the switch.

### **Installing SFP Transceivers**

This section contains instructions for installing SFP transceivers in the ports on the switch.

To install an SFP transceiver, perform the following procedure:

1. Remove the transceiver from its shipping container and store the packaging material in a safe location.
2. Slide the transceiver into a port until it clicks into place. Connect the fiber optic cable to the transceiver.

The connector on the cable should fit snugly into the port, and the tab should lock the connector into place.

3. Repeat this procedure to install and cable other transceivers.

## Installing Direct Attach Cables

---

To install direct attach cables, perform the following procedure:

---

**Note**

For a list of supported direct attach cables, refer to the product data sheet on the Allied Telesis web site at [www.alliedtelesis.com](http://www.alliedtelesis.com).

---

1. Select a port for the direct attach cable.
2. If the selected port has a dust cover, remove the cover.
3. Remove the direct attach cable from its shipping container and store the packaging material in a safe location.
4. Orient the connector of the direct attach cable and slide it into the port until it clicks into place.

The correct orientation depends on the cable.

5. Connect the other end of the cable into a compatible port on another network device.
6. Repeat this procedure to install other direct attach cables.

---

**Note**

To remove a cable from the port, gently push on the connector, pull on the release tab, and slide the connector from the port.

---

## Chapter 7

# Troubleshooting

---

This chapter contains suggestions on how to troubleshoot problems with the switch.

---

**Note**

For further assistance, please contact Allied Telesis Technical Support at [www.alliedtelesis.com/support](http://www.alliedtelesis.com/support).

---

**Problem 1:** The unit is not receiving power. All the port LEDs are off, and the fans are not operating.

**Solutions:** Try the following:

- ❑ Verify that the power cord is securely connected to the power source and AC connector on the back panel of the switch. The switch has two power supply units.
- ❑ Verify that the power outlet has power by connecting another device to it.
- ❑ Try connecting the unit to another power source.
- ❑ Try a different power cord.
- ❑ Verify that the voltage from the power source is within the required levels for your region. The power requirements for the switch are listed in “Power Specifications” on page 72.

**Problem 2:** All the port LEDs are off even though the ports are connected to active network devices.

**Solution:** The switch might be operating in low power mode. To toggle on the LEDs, press the eco-friendly button on the front panel of the switch. You can also toggle the LEDs off and on with the `ECOFRIENDLY LED` and `NO ECOFRIENDLY LED` commands in the command line interface.

**Problem 3:** A fiber optic transceiver or direct attach cable in QSFP28 or QSFP-DD ports on the switch is unable to establish a link to a network device.

**Solutions:** Try the following:

- ❑ Check that the transceiver or direct attach cable is fully inserted in the port.
- ❑ Verify that the fiber optic cable is securely connected to the port on the transceiver and the remote network device.
- ❑ Verify that the remote network device is operating properly.
- ❑ Verify that the operating specifications of the fiber optic ports and remote network device are compatible.
- ❑ Verify that the correct type of fiber optic cabling is being used.
- ❑ Verify that the port is connected to the correct fiber optic cable.
- ❑ Try connecting another network device to the fiber optic port using a different cable. If the port is able to establish a link, then the problem is with the cable or with the other network device.
- ❑ Use the switch's management software to verify that the port is enabled.
- ❑ If the remote network device is a managed device, use its management firmware to determine whether its port is enabled.
- ❑ If the problem is with two BiDi (bi-directional) transceivers, refer to their data sheets to verify that their transmission and reception frequencies are opposite each other. For instance, a BiDi transceiver that transmits and receives at 1310nm and 1550nm, respectively, has to be connected to a transceiver that transmits and receives at 1550nm and 1310nm, respectively. Two BiDi transceivers do not establish a link if they transmit and receive at the same frequencies.
- ❑ Test the attenuation of both directions on the fiber optic cable with a fiber optic tester to determine whether the optical signal is too weak or strong.
- ❑ Use the `SHOW PLATFORM` command to confirm that the port is configured correctly for the transceiver or direct attach cable. If necessary, use the `PLATFORM PORTMODE INTERFACE` command to configure the port. For more information, see "PLATFORM PORTMODE INTERFACE" on page 62.
- ❑ Changing a transceiver to one with a different speed requires restarting the switch. For example, restart the switch when changing a 40G transceiver on a port on the x980-32CQ switch to a 100G transceiver.

- ❑ If the problem is with a 100G transceiver, you might need to adjust the Forward Error Correction (FEC) parameter on the port, with the FEC command. Refer to the Software Reference for x980 switch, AlliedWare Plus Operating System.

**Problem 5:** The `SHOW STACK` command is not displaying all the switches in the stack.

**Solutions:** The switches are unable to form the stack. Try the following:

- ❑ The switches might have an earlier version of the management software that does not support VCStack, or they might have different versions. You can view the version number with the `SHOW VERSION` command.
- ❑ Review the information in “Stacking Port Guidelines” on page 33 to verify that the stack complies with all rules and restrictions.
- ❑ Verify that the fiber optic transceivers or direct attach cables that are used for the stack are fully inserted into the stacking ports.
- ❑ Verify that the transceivers or direct attach cables are from Allied Telesis.
- ❑ Verify that the fiber optic cables are securely connected to the ports on the transceivers or ports.
- ❑ Display the running configurations and confirm the stacking ports. They are identified by the `STACKPORT` command. In this example from a running configuration, ports 1 and 5 are the stacking ports:

```
awplus(config)# interface port1.0.1,port1.0.5
awplus(config-if)# stackport
```

- ❑ If necessary, repeat the `STACKPORT` command. For information, refer to “STACKPORT” on page 62. Afterwards, save your changes and reboot the switch.

**Problem 6:** You removed a port as a stacking port with the `NO STACKPORT` command, but the port is still not forwarding regular Ethernet traffic.

- ❑ Display the running configuration to verify that the port is no longer a stacking port.
- ❑ You must reboot the switch whenever you add or remove ports as stacking ports with the `STACKPORT` and `NO STACKPORT` commands. Be sure to save the change to the configuration file with the `WRITE` command before rebooting the unit.

**Problem 7:** The switch overheats and shuts down.

**Solutions:** Try the following:

- ❑ Verify that the location of the switch allows for adequate airflow.
- ❑ If the switch is operating, use the `SHOW SYSTEM ENVIRONMENT` command in the Privileged Exec mode to verify that the power supplies and fan modules are operating properly.

**Problem 8:** The switch functions intermittently.

**Solutions:** Try the following:

- ❑ Use the `SHOW SYSTEM ENVIRONMENT` command in the Privileged Exec mode to verify that the input voltage from the power source to the switch is stable and within the approved operating range. The unit shuts down if the input voltage fluctuates above or below the approved operating range.
- ❑ Use the `SHOW SYSTEM ENVIRONMENT` command in the Privileged Exec mode to verify that the fan modules are operating correctly.
- ❑ Verify that the location of the switch allows for adequate airflow. The unit will shut down if it overheats.

## Appendix A

# Technical Specifications

---

This appendix contains the following sections:

- "Physical Specifications" on page 70
- "Environmental Specifications" on page 71
- "Power Specifications" on page 72

## Physical Specifications

---

### **x980-32CQ Switch**

Dimensions:

- ❑ Height: 4.4 cm (1.7 in.)
- ❑ Width: 44 cm (17.3 in.)
- ❑ Depth: 49 cm (19.2 in.)

Weight: 9.4 kg (20.7 lb.) including two PSUs

### **x980-32DQ Switch**

- ❑ Height: 4.4 cm (1.72 in.)
- ❑ Width: 44 cm (17.32 in.)
- ❑ Depth: 57.2cm (22.5 in.)

Weight: 12.2 kg (26.9 lb.) including two PSUs

### **Ventilation**

The recommended minimum ventilation on all sides of the x980-32CQ or x980-32DQ switch is 10 cm (4.0 in.).

## Environmental Specifications

---

Table 12 lists the environmental specifications of the x980-32CQ switch.

Table 12. Environmental Specifications for x980-32CQ

Operating Temperature (Front panel to back panel)	0° C to 40° C (32° F to 104° F)
Operating Temperature (Back panel to front panel) This is optional.	0° C to 35° C (32° F to 95° F)
Storage Temperature	-25° C to 70° C (-13° F to 158° F)
Operating Humidity	5% to 90% noncondensing
Storage Humidity	5% to 95% noncondensing
Maximum Operating Altitude	3,000 m (9,842 ft)

Table 13 lists the environmental specifications of the x980-32DQ switch.

Table 13. Environmental Specifications for x980-32DQ

Operating Temperature (Front panel to back panel)	0° C to 40° C (32° F to 104° F)
Storage Temperature	-25° C to 70° C (-13° F to 158° F)
Operating Humidity	5% to 90% noncondensing
Storage Humidity	5% to 95% noncondensing
Maximum Operating Altitude	3,000 m (9,842 ft)

## Power Specifications

---

### Maximum Power Consumptions

Table 14. Maximum Power Consumption

x980-32CQ	649 Watt
x980-32DQ	1120 Watt

### Input Voltage and Frequency

Table 15. Input Voltages

x980-32CQ	100-120V~, 5A, 50/60Hz (x2) 200-240V~, 2.5A, 50/60Hz (x2)
x980-32DQ	100-127V~, 12A, 50/60Hz (x2) 200-240V~, 7A, 50/60Hz (x2)

### Heat Dissipation

Table 16. Heat Dissipation

x980-32CQ	649 w $\times 3.412 \approx 2,215$ BTU/hr
x980-32DQ	1120 w $\times 3.412 \approx 3,823$ BTU/hr