

# XS910/8

## 10 GIGABIT ETHERNET UNMANAGED SWITCH

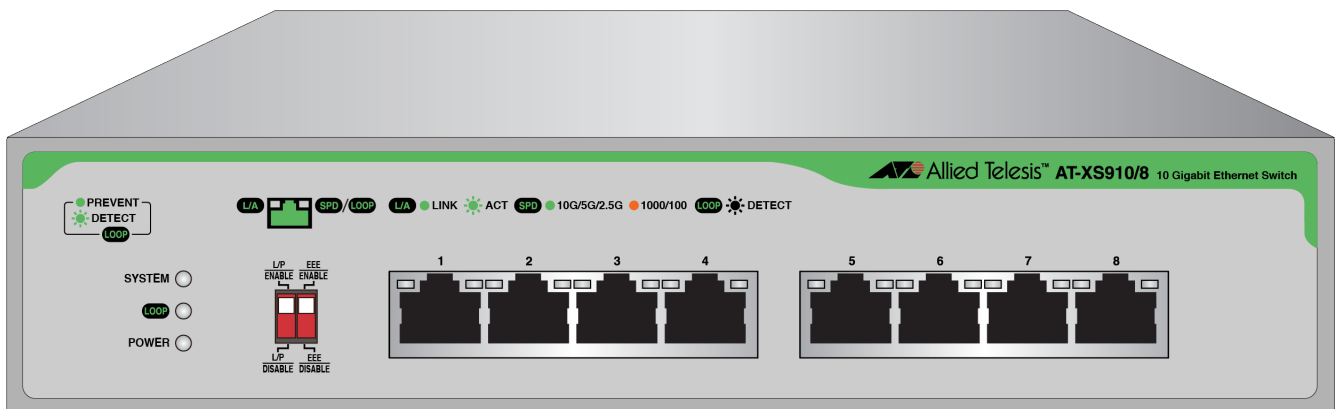

# Installation and User's Guide

Copyright © 2022 Allied Telesis, Inc.

All rights reserved. No part of this publication may be reproduced without prior written permission from Allied Telesis, Inc. Microsoft and Internet Explorer are registered trademarks of Microsoft Corporation. Netscape Navigator is a registered trademark of Netscape Communications Corporation. All other product names, company names, logos or other designations mentioned herein are trademarks or registered trademarks of their respective owners.

Allied Telesis, Inc. reserves the right to make changes in specifications and other information contained in this document without prior written notice. The information provided herein is subject to change without notice. In no event shall Allied Telesis, Inc. be liable for any incidental, special, indirect, or consequential damages whatsoever, including but not limited to lost profits, arising out of or related to this manual or the information contained herein, even if Allied Telesis, Inc. has been advised of, known, or should have known, the possibility of such damages.

# Electrical Safety and Emissions Standards

---

This section contains the following:

- “US Federal Communications Commission”
- “Industry Canada”
- “Electrical Safety, Electro Magnetic Interference, Electro Magnetic Susceptibility Standards” on page 4
- “Translated Safety Statements” on page 4

## US Federal Communications Commission

---

### Radiated Energy

---

**Note**

This equipment has been tested and found to comply with the limits for a Class A digital device pursuant to Part 15 of FCC Rules. These limits are designed to provide reasonable protection against harmful interference when the equipment is operated in a commercial environment. This equipment generates, uses, and can radiate radio frequency energy and, if not installed and used in accordance with this instruction manual, may cause harmful interference to radio communications. Operation of this equipment in a residential area is likely to cause harmful interference in which case the user will be required to correct the interference at his own expense.

---

**Note**

Modifications or changes not expressly approved of by the manufacturer or the FCC, can void your right to operate this equipment.

---

## Industry Canada

---

### Radiated Energy

This Class A digital apparatus complies with Canadian ICES-003.

Cet appareil numérique de la classe A est conforme à la norme NMB-003 du Canada.

# Electrical Safety, Electro Magnetic Interference, Electro Magnetic Susceptibility Standards

---

Electrical Safety	UL62368-1 (CUL <sub>US</sub> ), IEC62368-1 (UL-CB), EN62368-1 (UL-EU), CE
Electro Magnetic Interference (EMI):	FCC part 15 Subpart B, ICES-003:2020-Issue 7 Class A, EN55035:2017/A11:2020, EN55032:2012 / AC:2013 Class A, CISPR 32: 2012, VCCI Class A, RCM AS/NZS CISPR 32: 2013



## Warning

In a domestic environment this product may cause radio interference in which case the user may be required to take adequate measures. ⚡ E84

---

Electro Magnetic Susceptibility (EMS)	EN61000-4-2: 2009, EN61000-4-3: 2006 + A1:2008 + A2:2010, EN61000-4-4:2012, EN61000-4-5:2014, EN61000-4-6:2014, EN61000-4-8:2010, EN61000-4-11:2004, EN61000-3-2:2014, EN61000-3-3:2013
---------------------------------------	--

## Translated Safety Statements

---

**Important:** The ⚡ indicates that translations of the safety statement are available in the PDF document **Translated Safety Statements** posted on the Allied Telesis website at [alliedtelesis.com/library](http://alliedtelesis.com/library).

# Contents

---

<b>Preface</b> .....	7
Safety Symbols Used in this Document .....	8
Contacting Allied Telesis .....	9
<b>Chapter 1: Product Description</b> .....	11
Overview .....	12
Features .....	13
Key Features .....	13
Wall and Rack Mounting .....	14
LEDs .....	15
DIP Switches .....	16
100M/1G/2.5G/5G/10G Base-T Twisted Pair Ports .....	17
Power Connector .....	17
Loop Prevention .....	18
Root Switch .....	18
Non-root Switch .....	18
Examples with Multiple Loop Prevention Switches .....	19
Examples with Loop Prevention and Regular Switches .....	20
Examples within a Loop Prevention Switch .....	21
Guidelines for Loop Prevention .....	21
Enabling Loop Protection .....	21
Disabling Loop Protection .....	21
Energy Efficiency Ethernet (EEE) .....	22
Enabling EEE .....	22
Disabling EEE .....	22
Ethernet Switching Basics .....	23
Duplex Mode .....	23
Store-and- Forward .....	23
Flow Control .....	23
<b>Chapter 2: Installation</b> .....	25
Reviewing Safety Precautions .....	26
Selecting a Site and Planning the Installation .....	29
Unpacking the Switch .....	31
Installing the Switch on a Table or Desktop .....	32
Guidelines for Installing the Switch on a Table or Desktop .....	32
Installing the Switch on a Table or Desktop .....	32
Installing the Switch on a Wall .....	34
Guidelines for Installing the Switch on a Wall .....	34
Installing the Switch on a Wall .....	35
Installing the Switch in an Equipment Rack .....	36
Guidelines for Installing the Switch in a Rack .....	36
Installing the Switch in a Rack .....	36
Cabling the Switch .....	37
Powering On the Switch .....	38
<b>Chapter 3: Installation Using the AT-BRKT-J24 Wall Mount Bracket</b> .....	41
Unpacking the AT-BRKT-J24 Wall Mount Kit .....	42
Installing the Switch on a Wall Using the AT-BRKT-J24 Brackets .....	43
What to Prepare for Wall Installation .....	43
Installing the Switch on a Wall .....	43

<b>Chapter 4: Installation Using the AT-RKMT-J14 Rack Mount Kit</b> .....	47
Unpacking the AT-RKMT-J14 Rack Mount Kit .....	48
Installing a Switch Using the AT-RKMT-J14 Rack Mount Kit .....	49
What to Prepare .....	49
Installing a Switch Using the Rack Mount Kit .....	49
<b>Chapter 5: Installation Using the AT-RKMT-J15 Rack Mount Kit</b> .....	51
Unpacking the AT-RKMT-J15 Rack Mount Kit .....	52
Installing Two Switches in a Row of the Equipment Rack .....	53
What to Prepare .....	53
Installing Two Switches in a Row of the Equipment Rack .....	53
<b>Chapter 6: Troubleshooting</b> .....	57
<b>Appendix A: Technical Specifications</b> .....	59
Physical Specifications .....	59
Environmental Specifications .....	59
Power Specifications .....	60
RJ-45 Twisted Pair Port Connectors .....	60

# Preface

---

This manual is the installation and user's guide for the AT-XS910/8 10 Gigabit Ethernet Unmanaged Switch.

This Preface contains the following sections:

- "Safety Symbols Used in this Document" on page 8
- "Contacting Allied Telesis" on page 9

## Safety Symbols Used in this Document

---

This document uses the following conventions:

---

**Note**

Notes provide additional information.

---



**Caution**

Cautions inform you that performing or omitting a specific action may result in equipment damage or loss of data.

---



**Warning**

Warnings inform you that performing or omitting a specific action may result in bodily injury.

---

## Contacting Allied Telesis

---

If you need assistance with this product, you may contact Allied Telesis technical support by going to the Services & Support section of the Allied Telesis web site at **[www.alliedtelesis.com/support](http://www.alliedtelesis.com/support)**. You can find links for the following services on this page:

- ❑ Helpdesk (Support Portal) - Log onto Allied Telesis interactive support center to search for answers to your questions in our knowledge database, check support tickets, learn about Return Merchandise Authorizations (RMAs), and contact Allied Telesis technical experts.
- ❑ Software Downloads - Download the latest software releases for your product.
- ❑ Licensing - Register and obtain your License key to activate your product.
- ❑ Product Documents - View the most recent installation guides, user guides, software release notes, white papers and data sheets for your product.
- ❑ Warranty - View a list of products to see if Allied Telesis warranty applies to the product you purchased and register your warranty.
- ❑ Allied Telesis Helpdesk - Contact a support representative.

To contact a sales representative or find Allied Telesis office locations, go to **[www.alliedtelesis.com/contact](http://www.alliedtelesis.com/contact)**.



## Chapter 1

# Product Description

---

This chapter contains the follows sections:

- ❑ “Overview” on page 12
- ❑ “Features” on page 13
- ❑ “Loop Prevention” on page 18
- ❑ “Energy Efficiency Ethernet (EEE)” on page 22
- ❑ “Ethernet Switching Basics” on page 23

## Overview

---

The AT-XS910/8 switch is an unmanaged 10 Gigabit Ethernet switch with eight 100M/1G/2.5G/5G/10GBASE-T twisted-pair ports. This switch provides a simple solution to integrate 100Mbps, 1Gbps, 2.5Gbps, 5Gbps, and 10Gbps devices that exist in your network and expand the network to 10Gbps speed.

The eco-friendly feature automatically saves power consumption on each port when the port has not established a link. In addition, the switch does not require software configuration or management.

Figure 1 shows the front panel of the AT-XS910/8 switch.

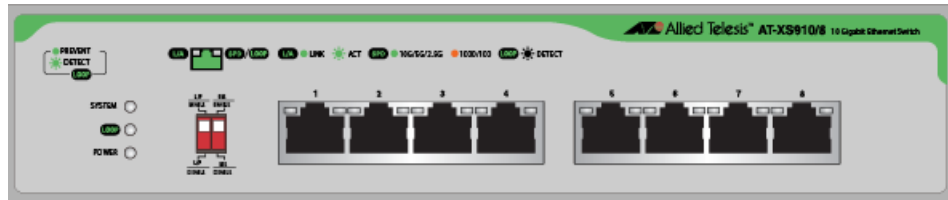

Figure 1. AT-XS910/8 Front Panel

Figure 2 shows the rear panel of the AT-XS910/8 switch.



Figure 2. AT-XS910/8 Rear Panel

The AT-XS910/8 switch can be installed on a desktop, mounted on a wall, or mounted in a 19-inch equipment rack. To mount the switch on a wall, use the AT-BRKT-J24 wall mount brackets. To install one switch in a row of an equipment rack, use the AT-RKMT-J14 rack mount brackets, and use the AT-RKMT-J15 rack mount brackets for two switches in one row.

---

**Note**

The AT-BRKT-J24, AT-RKMT-J14, and AT-RKMT-J15 brackets are *not* included in the shipping box. You must purchase them separately.

---

## Features

---

This section describe the features of the AT-XS910/8 switch.

### Key Features

Here is a list of key features:

- ❑ Eight 100M/1G/2.5G/5G/10GBASE-T twisted pair ports with RJ-45 connectors
- ❑ IEEE802.3u compliant for 100Base-TX
- ❑ IEEE802.3ab compliant for 1000Base-T
- ❑ IEEE802.3bz compliant for 2.5GBase-T and 5GBase-T
- ❑ IEEE802.3an compliant for 10Gbps Ethernet
- ❑ IEEE 802.3az Energy Efficient Ethernet, which is enabled or disabled from the DIP switch on the front panel
- ❑ Auto-Negotiation
- ❑ Store-and-Forward switching method
- ❑ Jumbo frames of 12Kbytes (inclusive) without frame loss and drop packet, which is larger than 12Kbytes (exclusive)
- ❑ Up to 16,384 MAC address entries
- ❑ Link down power saving
- ❑ IEEE 802.3x pause frame in the full-duplex mode
- ❑ Loop Detection and Prevention, which is enabled or disabled from the DIP switch on the front panel
- ❑ Diagnostic LEDs
- ❑ RoHS compliant
- ❑ Wall mounting
- ❑ Equipment Rack mounting with one or two units in a row.

## Wall and Rack Mounting

The switch can be installed on a table top, wall, and equipment rack. Table 1 shows optional brackets for the AT-XS910/8 switch.

Table 1. Wall and Rack Mount Brackets

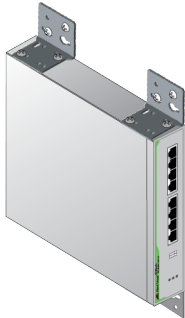
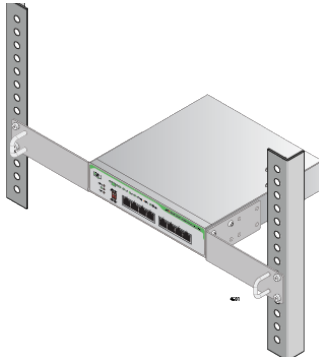
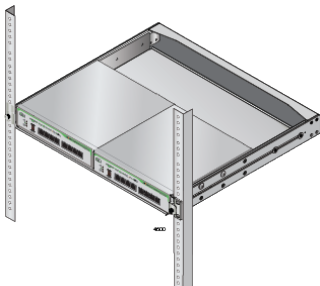
Installation		Optional Mount Kit
Wall		AT-BRKT-J24
Equipment Rack: one switch in a row		AT-RKMT-J14
Equipment Rack: two switches in a row		AT-RKMT-J15

**LEDs** The LEDs on the front panel of the AT-XS910/8 switch display status information. See Figure 3.

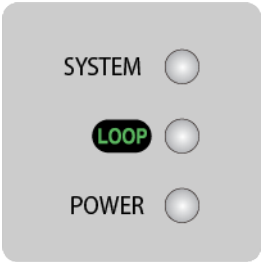

Figure 3. Switch LEDs

Table 2 describes the switch LEDs.

Table 2. LEDs for the Switch

LED	State	Description
SYSTEM	Red	The system is booting up.
	Off	The system is operating normally.
LOOP	Green	Loop Prevention is enabled.
	Blinking Green	A loop has been detected and the switch blocks the looped port to stop the loop.
	Off	Loop Prevention is disabled.
POWER	Green	The switch is powered on.
	Off	The switch is not receiving power.

The LEDs on the ports display status information. The LED at the left corner of the port indicates the link/activity; the LED on the right corner indicates the speed and status of Loop Prevention. See Figure 4.

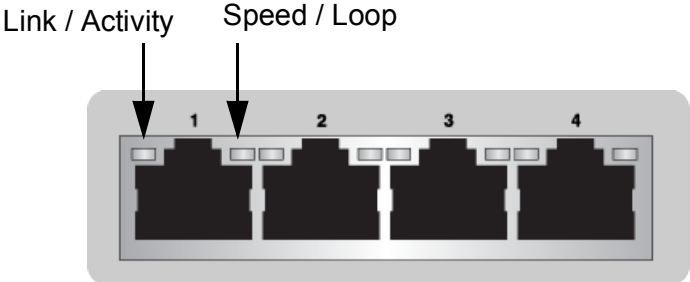

Figure 4. Port LEDs

Table 3 describes the Port LEDs.

Table 3. LEDs for the Ports

LED	State	Description
Link/Activity	Green	The port has established a link to a network device.
	Blinking Green	The port is transmitting or receiving frames.
	Off	The port has not established a link with a network device.
Speed/Loop	Green	The port is operating at 2.5G/5G/10Gbps.
	Amber	The port is operating at 100/1000Mbps.
	Blinking Green	A loop is detected while the port is operating at 2.5/5/10Gbps. The switch blocks the looped port to stop the loop.
	Blinking Amber	A loop is detected while the port is operating at 100/1000Mbps. The switch blocks the looped port to stop the loop.
	Off	No link is established at the port.

### DIP Switches

The switch has two DIP switches on the front panel. You can turn on or off Loop Prevention and Energy Efficient Ethernet (EEE). See Figure 5.

When the DIP switch is in the up position, a function is enabled; the DIP switch is in the down position, the function is disabled.

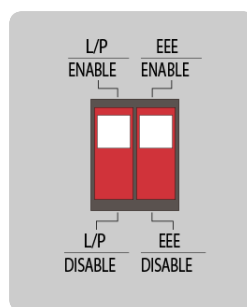

Figure 5. DIP Switches

For more information about Loop Prevention: see “Loop Prevention” on page 18, and for EEE, see “Energy Efficiency Ethernet (EEE)” on page 22.

## **100M/1G/2.5G/5G/10G Base-T Twisted Pair Ports**

The AT-XS910/8 switch is equipped with eight 100M/1G/2.5G/5G/10G BASE-T twisted pair ports

### **Connector**

All twisted pair ports feature 8-pin RJ-45 connectors. For the port pinouts, see “RJ-45 Twisted Pair Port Connectors” on page 60.

### **Speed**

The ports are 100M/1G/2.5G/5G/10G BASE-T compliant and capable of 100 Mbps, 1Gbps, 2.5Gbps, 5Gbps and 10Gbps speeds. The ports are IEEE 802.3u Auto-Negotiation compliant. With Auto-Negotiation, the switch automatically matches the highest possible common speed between the switch port and its end-node.

### **Duplex Mode**

The twisted pair ports on the switch operate in the full-duplex mode.

### **Auto MDI/MDI-X**

All of the twisted pair ports on the switch feature auto-MDI to automatically configure themselves as MDI or MDI-X when connected to an end-node. Consequently, you can use a straight-through twisted pair cable to connect any network device to a port.

## **Power Connector**

The switch has a single AC power supply socket on the back panel as shown in Figure 2 on page 12. To power ON or OFF the switch, connect or disconnect the power cord.

## Loop Prevention

---

The AT-XS910/8 switch is equipped with Loop Prevention, a feature that detects loops and blocks ports in order to reduce negative effects on the local network while keeping connectivity of devices. Loops in Ethernet networks can cause broadcast storms that consume network bandwidth and reduce network performance.

When Loop Prevention is enabled, the switch sends Loop Prevention frames periodically and detects a loop in the LAN when a port receives the Loop Prevention frame sent by the port itself. Then, the switch applies the loop prevention algorithm to block ports to relieve the loop.

When the switch detects a loop and blocks a port, the following actions are taken:

- ❑ The Loop LED starts blinking.
- ❑ The LED of the blocked port starts blinking.

### Root Switch

In a topology with multiple AT-XS910/8 switches, they elect a root switch when Loop Prevention is enabled on all the switches. Initially, these switches are all root switches. They send Loop Prevention frames and elect the root switch by comparing their switch priorities. The switch with the highest switch priority becomes the root switch. When multiple switches have the same highest switch priority, the switch with the lowest MAC address becomes the root switch.

### Non-root Switch

The switches, which are not selected as the root switch, are non-root switches. The root switch sends Loop Prevention frames from its ports every two seconds. A non-root switch updates the Loop Prevention frames and forwards them. A non-root switch also maintains a timer for each port and sets a timer to 16 seconds. When receiving a Loop Prevention frame at a port, a non-root switch refreshes the timer of the port. When all timers of the non-root switch reach zero, the non-root switch changes itself to a root switch and sends Loop Prevention frames.

### Examples with Multiple Loop Prevention Switches

In examples shown in Figure 6, multiple AT-XS910/8 switches form links and all switches are Loop Prevention enabled. Switch C has a lower MAC address than Switch A and Switch B; Switch B has a lower MAC address than Switch A.

First, these switches elect a root switch by comparing the MAC addresses. In cases 1 and 2, Switch B is elected as a root switch; in case 3, Switch C is elected as a root switch.

Then the root switch initiates Loop Prevention frames and non-root switches update the frames and forward them. When detecting a loop, the root switch runs the Loop Prevention algorithm to decide which port to block, and blocks a port or ports to relieve the loop.

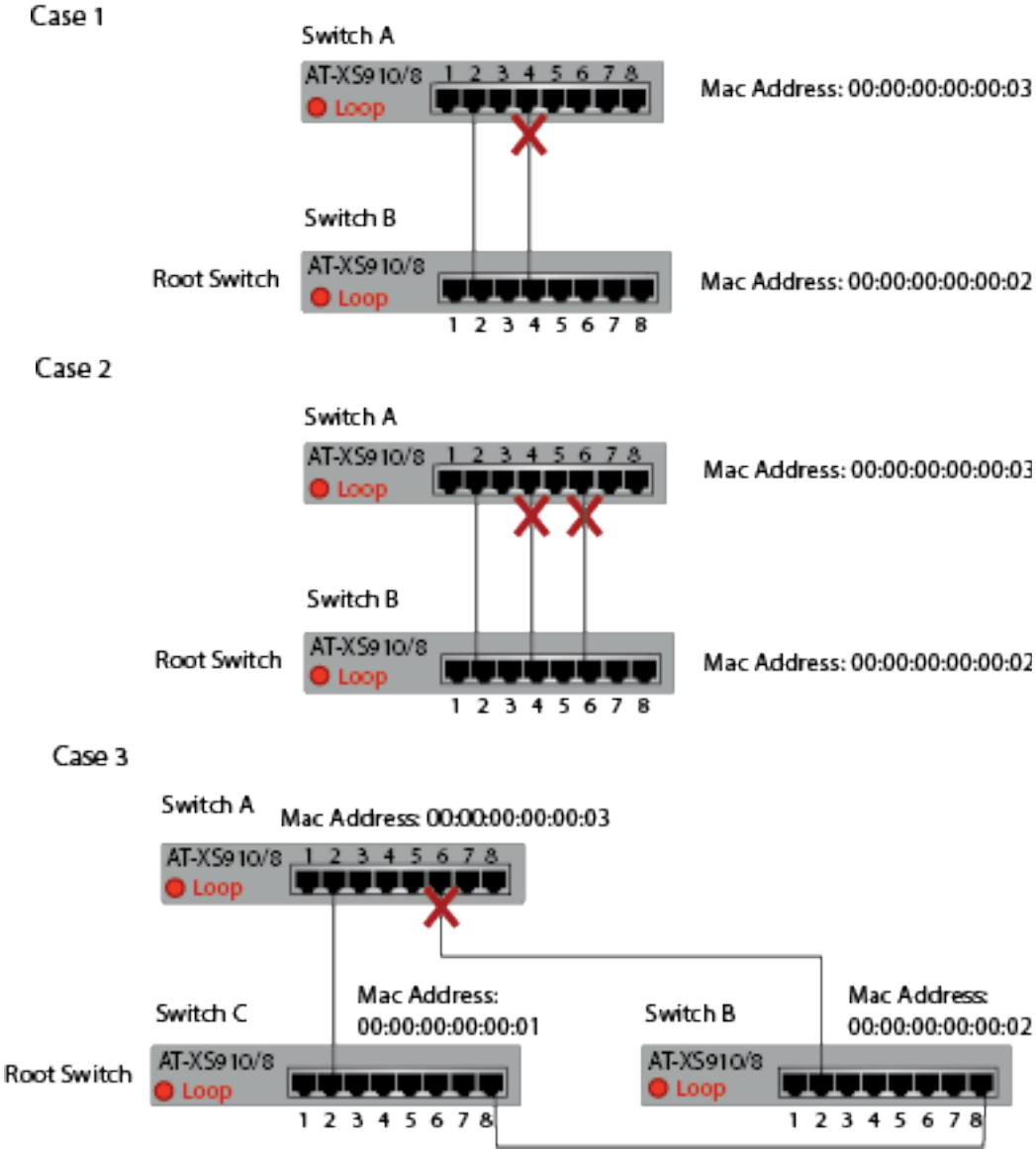

Figure 6. Multiple AT-XS910/8 Switches for Loop Prevention

### Examples with Loop Prevention and Regular Switches

In examples shown in Figure 7, the AT-XS910/8 switch and a regular switch form links. When Loop Prevention is enabled, the AT-XS910/8 switch sends Loop Prevention frames. When detecting a loop, the switch blocks a port or ports except the port with the smallest number.

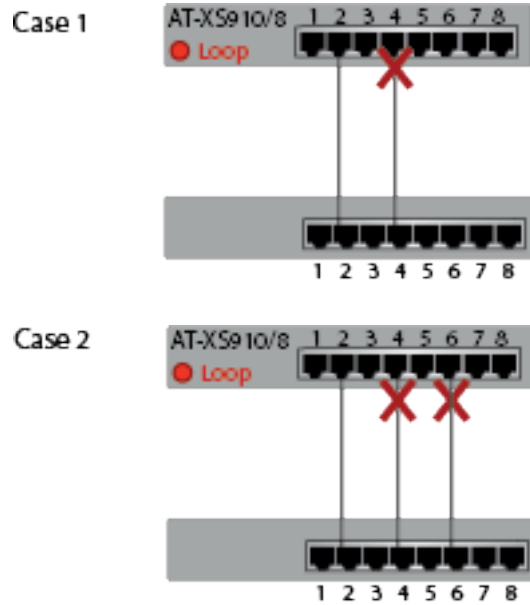

Figure 7. AT-XS910/8 and Regular Switches for Loop Prevention

In an example shown in Figure 8, the AT-XS910/8 switch and a regular switch form a link. The regular switch is causing a loop. When receiving a Loop Prevention frame, the AT-XS910/8 switch blocks its port.

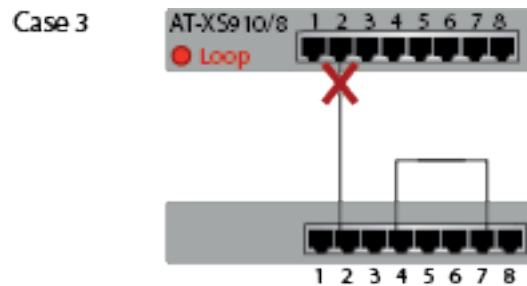

Figure 8. AT-XS910/8 and Regular Switches for Loop Prevention - Case 3

## Examples within a Loop Prevention Switch

In examples shown in Figure 9, the ports of the AT-XS910/8 switch connected. When Loop Prevention is enabled, the AT-XS910/8 switch blocks the port with the higher port number than the link partner port.

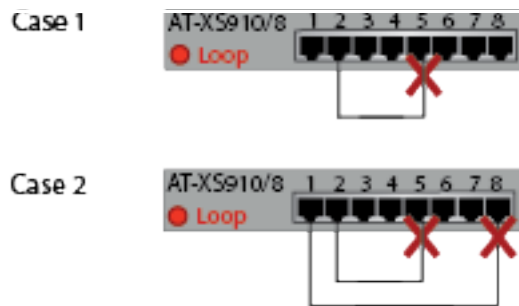

Figure 9. AT-XS910/8 Switch with Loop Prevention

## Guidelines for Loop Prevention

Here are guidelines for using the Loop Prevention function:

- The switch must have a unique MAC address.
- In a topology with multiple switches with Loop Prevention enabled, these switches select a root switch.
- The switch with a lower MAC address is selected as a root switch.
- Only a root switch blocks its port(s) when a loop is detected.
- A port receives Loop Prevention frames even when the port is blocked.

## Enabling Loop Protection

To enable Loop Prevention, set the Loop Prevention DIP switch on the front panel to the up position. When Loop Prevention is enabled, Flow Control is disabled.

## Disabling Loop Protection

To disable Loop Prevention, set the Loop Prevention DIP switch on the front panel to the down position. When Loop Prevention is disabled, Flow Control is enabled.

## Energy Efficiency Ethernet (EEE)

---

The AT-XS910/8 switch supports IEEE 802.3az Energy Efficiency Ethernet (EEE). When EEE is enabled on the switch, the power consumption is reduced during periods of low data activity.

**Enabling EEE** To enable EEE, set the Loop Prevention DIP switch on the front panel to the up position.

**Disabling EEE** To disable EEE, set the Loop Prevention DIP switch on the front panel to the down position.

## Ethernet Switching Basics

---

An Ethernet switch interconnects network devices, such as workstations, printers, routers, and other Ethernet switches, so that they can communicate with each other by sending and receiving Ethernet frames.

**Duplex Mode** The AT-XS910/8 switch operates in the full-duplex mode.

**Store-and-Forward** The AT-XS910/8 switch uses store-and-forward as the method for receiving and transmitting frames. When an Ethernet frame is received on a switch port, the switch does not retransmit the frame out the destination port until it has received the entire frame and stored the frame in a port buffer. It then examines the frame to determine if it is a valid frame. Invalid frames, such as fragments or runts, are discarded by the switch. This insures that only valid frames are transmitted out the switch ports and that damaged frames are not propagated on your network.

**Flow Control** Flow Control is a mechanism to manage the rate of data transmission between two nodes and prevent a faster sender from overwhelming a slower receiver. An Ethernet switch may periodically need to signal an end-node to stop sending data. When two end-nodes are operating at different speeds, the switch, while transferring data between the end-nodes, might need to instruct the faster end-node to stop transmitting data to allow the slower end-node to catch up. An example of this would be when a server operating at 10Gbps is sending data to a workstation operating at only 1Gbps.

The ports on the AT-XS910/8 switch use PAUSE frames, as specified in the IEEE 802.3x standard, to stop the transmission of data from an end-node. Whenever the switch wants an end-node to stop transmitting data, it issues this frame. The frame instructs the end-node to cease transmission for a period of time specified within the frame. The switch continues to issue PAUSE frames until it is ready again to receive data from the end-node.



## Chapter 2

# Installation

---

This chapter contains the following sections:

- ❑ “Reviewing Safety Precautions” on page 26
- ❑ “Selecting a Site and Planning the Installation” on page 29
- ❑ “Unpacking the Switch” on page 31
- ❑ “Installing the Switch on a Table or Desktop” on page 32
- ❑ “Installing the Switch on a Wall” on page 34
- ❑ “Installing the Switch in an Equipment Rack” on page 36
- ❑ “Cabling the Switch” on page 37
- ❑ “Powering On the Switch” on page 38

## Reviewing Safety Precautions

---

Review the following safety precautions before you begin to install the switch.

---

### Note

**Important:** The ⚡ indicates that translations of the safety statement are available in the PDF document *Translated Safety Statements* posted on the Allied Telesis website at [alliedtelesis.com/support](http://alliedtelesis.com/support).

---



### Warning

To prevent electric shock, do not remove the cover. No user-serviceable parts inside. This unit contains hazardous voltages and should only be opened by a trained and qualified technician. To avoid the possibility of electric shock, disconnect electric power to the product before connecting or disconnecting the cables. ⚡ E1

---



### Warning

Do not work on equipment or cables during periods of lightning activity. ⚡ E2

---



### Warning

Power cord is used as a disconnection device. To de-energize equipment, disconnect the power cord. ⚡ E3

---



### Warning

Class I Equipment. This equipment must be earthed. The power plug must be connected to a properly wired earth ground socket outlet. An improperly wired socket outlet could place hazardous voltages on accessible metal parts. ⚡ E4

---



### Caution

Air vents must not be blocked and must have free access to the room ambient air for cooling. ⚡ E6

---



### Warning

Operating Temperature. This product is designed for a maximum ambient temperature of 50 degrees C. ⚡ E57

---

---

**Note**

All Countries: Install product in accordance with local and National Electrical Codes. ⚡ E8

---

---

**Note**

The power input must be provided from SELV source only, per IEC62368. Do not connect to a centralized DC battery bank.

---

**Warning**

An insecurely attached device on a wall may fall and the falling device may lead to damaging itself or causing injuries. ⚡ E96

---

**Warning**

Do not install the device on an unstable wall or a wall affected by vibration or impact. The device may fall and falling device may lead to damaging itself or causing injuries. ⚡ E97

---

**Warning**

Do not install the device high on a wall. The device may fall and the falling device may lead to damaging itself or causing injuries. ⚡ E98

---

**Warning**

Disconnecting the Device: If the device becomes damaged or you encounter abnormality with the device, disconnect the power plug from the AC wall outlet immediately. ⚡ E100

---

**Warning**

Use appropriate screws to attach the device and brackets to a 19-inch rack. If a device is installed insecurely in a rack, it may fall, potentially causing injuries or damage to the device. ⚡ E104

---

When you plan to install your switch in an equipment rack, review the following safety precautions in addition to the above safety precautions.

**Warning**

Mounting of the equipment in the rack should be such that a hazardous condition is not created due to uneven mechanical loading. ⚡ E25

---



**Caution**

Installation of the equipment in a rack should be such that the amount of air flow required for safe operation of the equipment is not compromised. ⚡ E36

---



**Warning**

Reliable earthing of rack-mounted equipment should be maintained. Particular attention should be given to supply connections other than direct connections to the branch circuits (e.g., use of power strips). ⚡ E37

---

---

**Note**

Circuit Overloading: Consideration should be given to the connection of the equipment to the supply circuit and the effect that overloading of circuits might have on over current protection and supply wiring. Appropriate consideration of equipment nameplate ratings should be used when addressing this concern. ⚡ E21

---

---

**Note**

Elevated Operating Ambient - If installed in a closed or multi-unit rack assembly, the operating ambient temperature of the rack environment may be greater than room ambient. Therefore, consideration should be given to installing the equipment in an environment compatible with the maximum ambient temperature (T<sub>ma</sub>) specified by the manufacturer.

---

## Selecting a Site and Planning the Installation

---

Observe the following requirements when choosing a site for the AT-XS910/8 switch:

- ❑ If you plan to install the switch on a table, make sure that the table is level and secured.
- ❑ If you plan to install the switch on a wall, make sure that the wall is straight and secured.
- ❑ If you plan to install the switch in an equipment rack, make sure that the rack is safely secured and it will not tip over. Devices in a rack should be installed starting at the bottom, with the heavier devices near the bottom of the rack.
- ❑ The power outlet for the switch should be located near the unit and should be easily accessible.
- ❑ The site should provide for easy access to the ports on the back of the switch and the LEDs on the front of the switch should be easily viewed.
- ❑ To allow proper cooling off the switch, air flow around the unit and through its vents on the side should not be restricted.
- ❑ Do not place objects on top of the switch.
- ❑ Do not expose the switch to moisture or water.
- ❑ Ensure that the site is a dust-free environment.
- ❑ Use dedicated power circuits or power conditioners to supply reliable electrical power to the network devices.
- ❑ Table 4 contains the cabling specifications for the twisted pair ports.

Table 4. Twisted Pair Cabling and Distances

Speed	Type of Cable	Maximum Operating Distance
100 Mbps	Standard TIA/EIA 568A-compliant Category 5 or TIA/EIA 568B-compliant Enhanced Category 5 (Cat 5e) unshielded Cabling	100 m (328 ft)
1 Gbps		
2.5 Gbps		
5 Gbps	Standard TIA/EIA 568C-compliant Category 6 unshielded cabling	
10 Gbps	Standard TIA/EIA 568C-compliant Category 6a unshielded cabling	

---

**Note**

The twisted pair ports on the switch feature Auto-MDI when operating at 100 Mbps. Each port is individually configured as MDI or MDI-X when connected to an end-node. Consequently, you can use a straight-through twisted pair cable when connecting any network device to a twisted pair port on the switch. A port operating at 100 Mbps uses four of the eight strands in twisted pair wiring.

---

## Unpacking the Switch

To unpack the AT-XS910/8 switch, perform the following procedure:

1. Remove all components from the shipping package.

---



### Note

Store the packaging material in a safe location. You must use the original shipping material if you need to return the unit to Allied Telesis.

---

2. Place the switch on a level, secure surface.
3. Verify that the hardware components are included in your switch package.

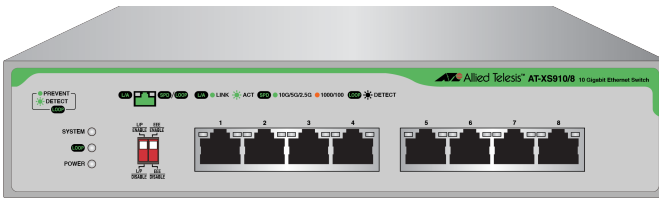
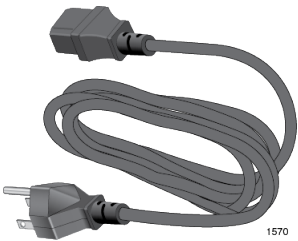
Table 5. Components in the Bracket Kit

Description	Item
AT-XS910/8 switch	
AC power cord	
Retaining Clip	

4. If any item is missing or damaged, contact your Allied Telesis sales representative for assistance.

## Installing the Switch on a Table or Desktop

When installing the switch on a table or desktop, see the guidelines before install it.

### Guidelines for Installing the Switch on a Table or Desktop

Before planning to install the switch on a table or desktop, review the following guidelines:

- ❑ The bottom of the switch touching the table or desktop is only the connect orientation. See Figure 10.

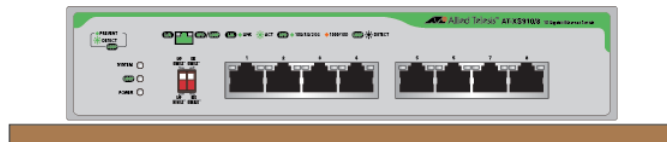

Figure 10. Correct Table or Desktop Orientation

- ❑ Figure 11 shows incorrect orientations.

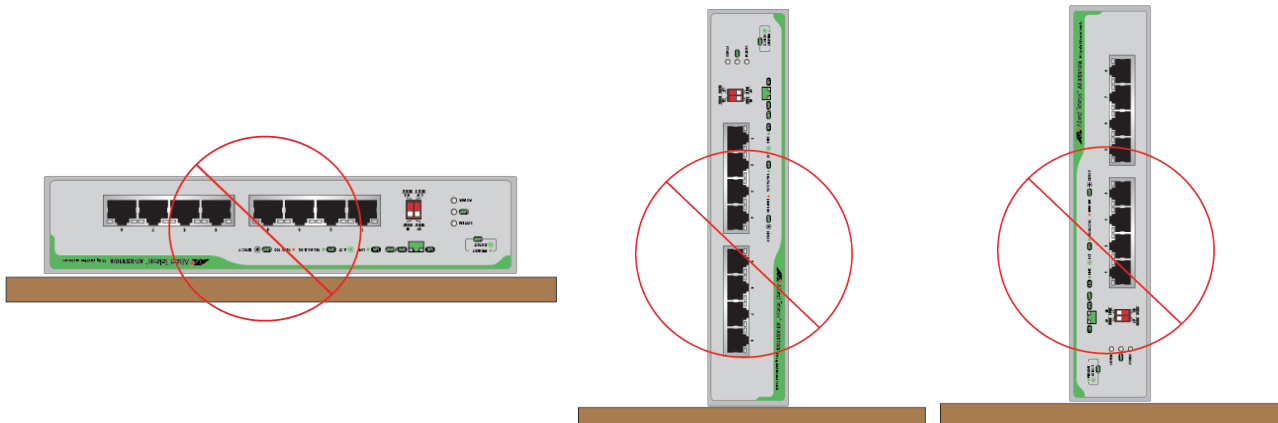

Figure 11. Incorrect Table or Desktop Orientation

### Installing the Switch on a Table or Desktop

To install the switch on a table or desktop, perform the following procedure:

1. Review “Reviewing Safety Precautions” on page 26 and “Selecting a Site and Planning the Installation” on page 29 before performing this procedure.
2. Remove all the items from the packaging.
3. Store the packaging material in a safe place.

In the event a problem occurs and you need to return the unit, use as much of the original shipping material as possible.

4. Place the switch on a flat and secure surface, leaving ample space around the switch for ventilation.
5. Proceed to “Cabling the Switch” on page 37 for the cable installation.

## Installing the Switch on a Wall

---

The AT-XS910/8 switch can be mounted on a wall.

### Guidelines for Installing the Switch on a Wall

Before planning to install the switch on a wall, review the following guidelines:

- ❑ To install the switch on a wall, use the AT-BRKT-J24 wall mount brackets.

---

#### Note

You must purchase the AT-BRKT-J24 wall mount bracket kit separately.

- ❑ The switch can be mounted on the wall horizontally or vertically. Figure 12 shows correct orientations.



Figure 12. correct Wall Installation Orientation



#### Warning

An insecurely attached device on a wall may fall and the falling device may lead to damaging itself or causing injuries. ⚡ E96



#### Warning

Do not install the device on an unstable wall or a wall affected by vibration or impact. The device may fall and falling device may lead to damaging itself or causing injuries. ⚡ E97

---



**Warning**

Do not install the device high on a wall. The device may fall and the falling device may lead to damaging itself or causing injuries. ⚡ E98

---

**Note**

Installing the device on a wall may damage the wall paint.

---

**Installing the  
Switch on a Wall**

To install the switch on a wall, see “Installation Using the AT-BRKT-J24 Wall Mount Bracket” on page 41.

## Installing the Switch in an Equipment Rack

---

You can install one AT-XS910/8 switch in a row of the equipment rack or two AT-XS910/8 switches in one row of the equipment rack as shown in Figure 13.

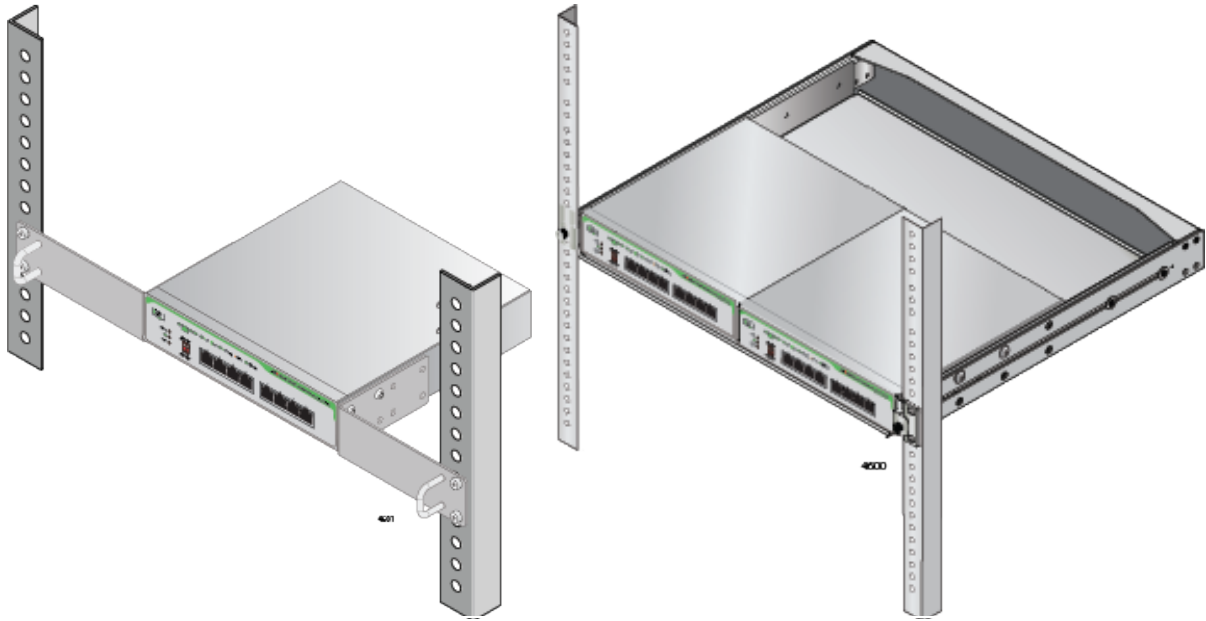

Figure 13. Rack Installation Options

### Guidelines for Installing the Switch in a Rack

Before planning to install the switch on an equipment rack, review the following guidelines:

- ❑ To install one AT-XS910/8 switch in an equipment rack, use the AT-RKMT-J14 rack mount kit.
- ❑ To install two AT-XS910/8 switches in one plate to an equipment rack, use the AT-RKMT-J15 rack mount kit.

---

#### Note

You must purchase the AT-RKMT-J14 or AT-RKMT-J15 rack mount kit separately.

---

### Installing the Switch in a Rack

You can either one switch or two switches in a row of an equipment rack:

- ❑ To install one switch on an equipment rack, see “Installation Using the AT-RKMT-J14 Rack Mount Kit” on page 47.
- ❑ To install one switch on an equipment rack, see “Installation Using the AT-RKMT-J15 Rack Mount Kit” on page 51.

## Cabling the Switch

---

After installing the switch on the desktop, connect twisted pair cables to the ports on the AT-XS910/8 switch.

When connecting a twisted pair cable to a port, observe the following guidelines:

- ❑ An RJ-45 connector should fit snugly into the port on the switch. The tab on the connector should lock the connector into place.
- ❑ The ports on the switch are auto-MDI/MDI-X. You can use a straight-through twisted pair cable to connect any type of network device to a port on the switch.
- ❑ The network should not contain data loops, which can adversely affect network performance. A data loop exists when two or more network devices can communicate with each other over more than one data path.

## Powering On the Switch

---

Before powering on the switch, reviewing the information in “Power Specifications” on page 60.



---

**Warning**

Power cord is used as a disconnection device. To de-energize equipment, disconnect the power cord. ⚡ E3

---

**Note**

Pluggable Equipment. The socket outlet shall be installed near the equipment and shall be easily accessible. ⚡ E5

---

To power on the switch, perform the following procedure:

1. Install the power cord retaining clip on the AC power connector on the rear panel of the switch. See Figure 14.

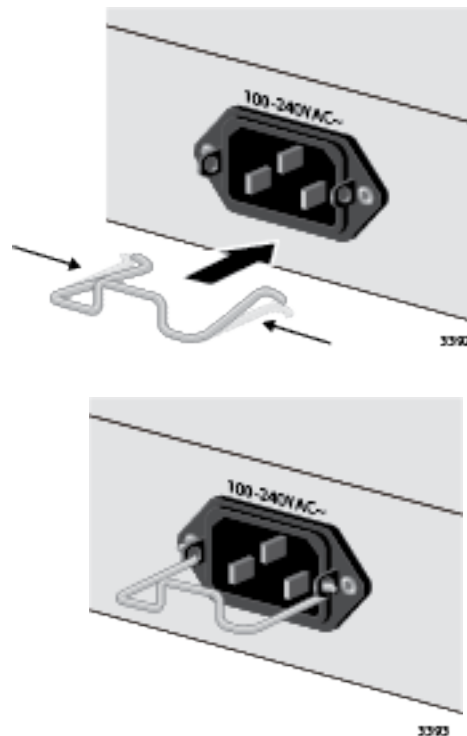

Figure 14. Installing the Power Cord Retainer Clip

2. Connect the AC power cord to the AC power connector on the rear panel. See Figure 15.

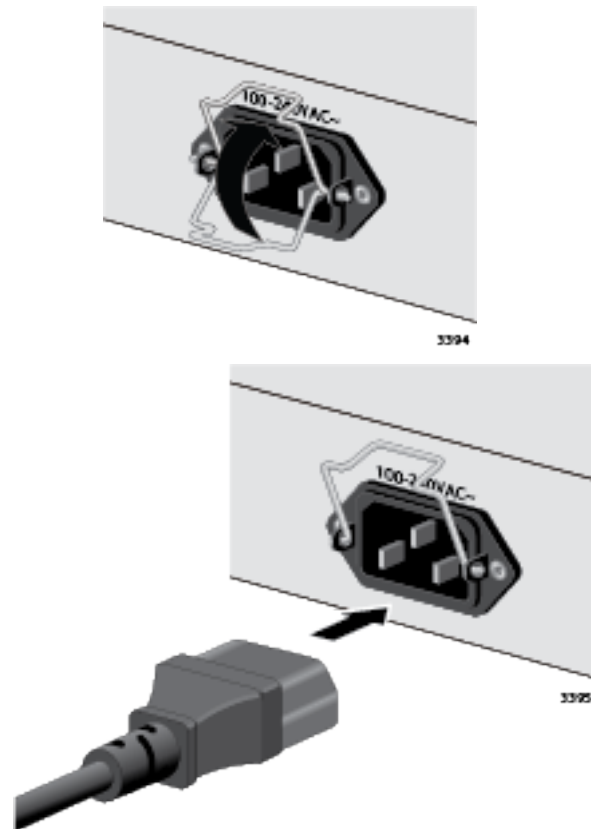

Figure 15. Connecting the AC Power Cord

3. Lower the power cord retaining clip to secure the cord to the switch as shown in Figure 16.

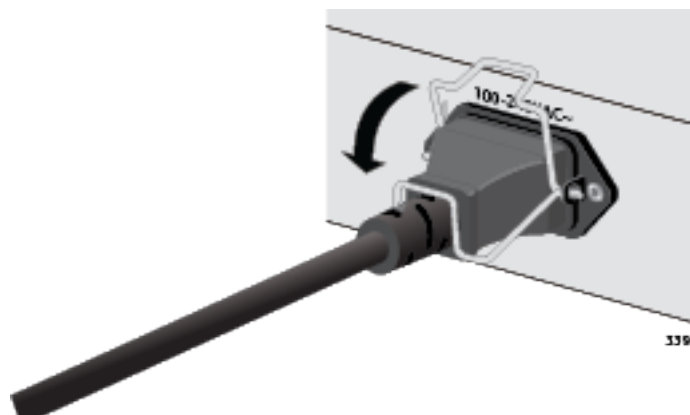

Figure 16. Lowering the Power Cord Retainer Clip

4. Connect the power cord to an appropriate AC power source.

5. Verify that the POWER LED is green. If the LED is OFF, see Chapter 6, "Troubleshooting" on page 57.

The switch is now powered on and ready for network operations.



**Warning**

Disconnecting the Device: If the device becomes damaged or you encounter abnormality with the device, disconnect the power plug from the AC wall outlet immediately. ⚡ E100

---

## Chapter 3

# Installation Using the AT-BRKT-J24 Wall Mount Bracket

---

This chapter contains the follows sections:

- “Unpacking the AT-BRKT-J24 Wall Mount Kit” on page 42
- “Installing the Switch on a Wall Using the AT-BRKT-J24 Brackets” on page 43

## Unpacking the AT-BRKT-J24 Wall Mount Kit

To unpack the AT-BRKT-J24 wall mount kit, perform the following procedure:

1. Remove all components from the shipping package.

---



**Note**

Store the packaging material in a safe location. You must use the original shipping material if you need to return the unit to Allied Telesis.

---

2. Verify that One pair of brackets is included in your wall mount package listed in Table 6.

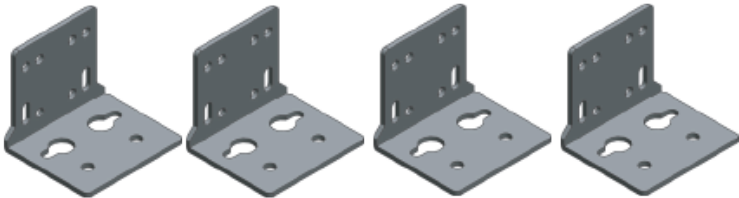
Table 6. Components in the AT-BRKT-J24 Wall Mount Kit

	<b>Components</b>
Four brackets	
16 M4x6mm screws	

3. If any item is missing or damaged, contact your Allied Telesis sales representative for assistance.

## Installing the Switch on a Wall Using the AT-BRKT-J24 Brackets

---

The switch can be mounted on a wall using the AT-BRKT-J24 wall mount bracket kit.

### What to Prepare for Wall Installation

You need the following items to install the switch on a wall:

- Four AT-BRKT-J24 brackets
- 16 M4mm x 6mm screws to attach the brackets to the switch (included in the AT-BRKT-J24 kit)
- Eight 4mm x 32mm wood screws for wall mounting (not included)
- Phillips-head screwdriver
- Pencil
- Drill

---

#### Note

You must provide screws to attach the brackets to the switch, a cross-head screwdriver, a pencil, and a drill.

---

### Installing the Switch on a Wall

To install the switch on a wall, perform the following procedure:

1. Review “Reviewing Safety Precautions” on page 26 and “Selecting a Site and Planning the Installation” on page 29 before performing this procedure.
2. Place all the items from the packaging on a work table.
3. Attach each bracket to the switch using four screws as shown in Figure 17 on page 44.

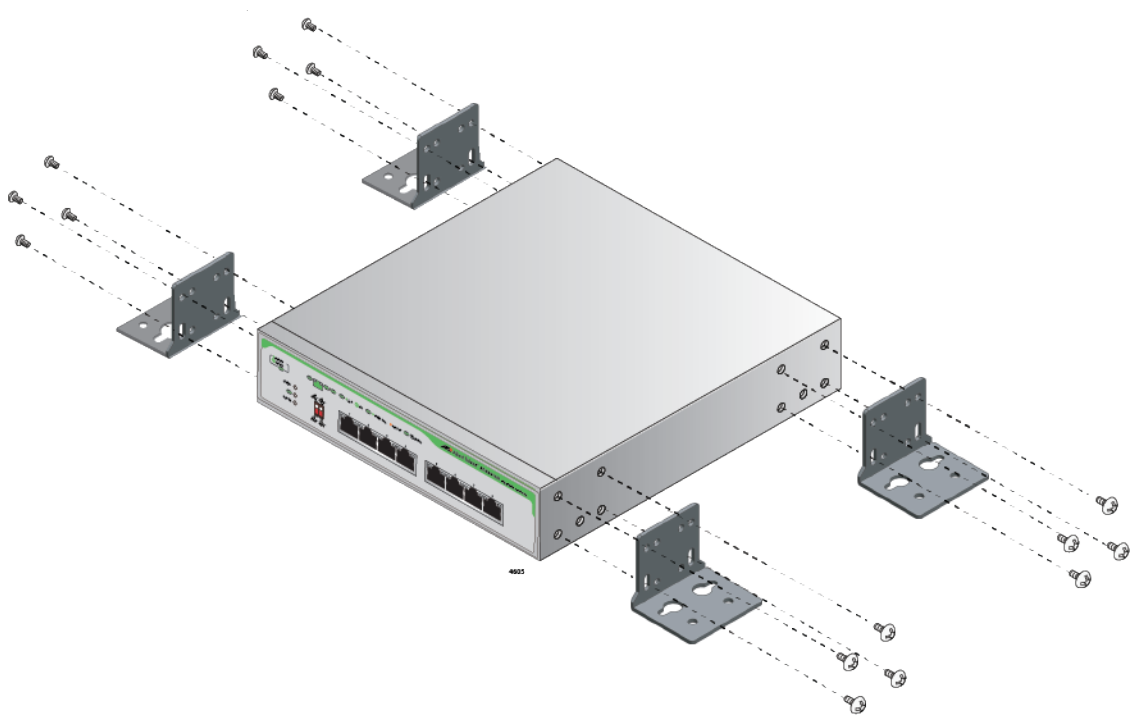

Figure 17. Attaching the Wall Brackets

4. While another person holds the switch at the wall location, mark the holes with a pencil.
5. Pre-drill the marked holes.
6. While another person holds the switch at the wall location, secure the switch to the wall using the eight wall mounting screws. See Figure 18 on page 45.

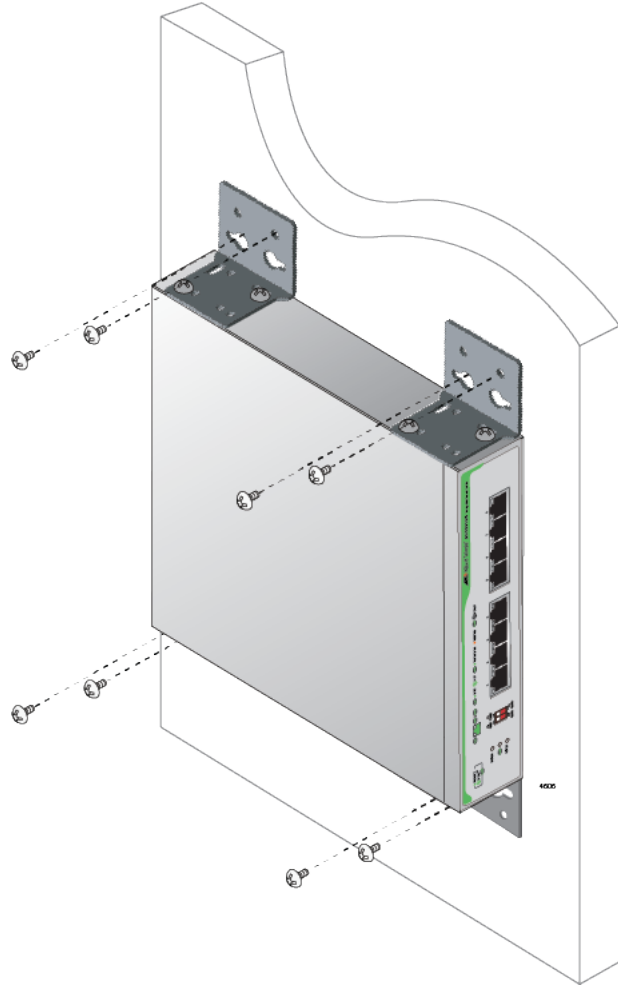

Figure 18. Installing the Switch on the Wall



## Chapter 4

# Installation Using the AT-RKMT-J14 Rack Mount Kit

---

This chapter contains the follows sections:

- “Unpacking the AT-RKMT-J14 Rack Mount Kit” on page 48
- “Installing a Switch Using the AT-RKMT-J14 Rack Mount Kit” on page 49

## Unpacking the AT-RKMT-J14 Rack Mount Kit

To unpack the AT-RKMT-J14 rack mount kit, perform the following procedure:

1. Remove all components from the shipping package.

---





**Note**

Store the packaging material in a safe location. You must use the original shipping material if you need to return the unit to Allied Telesis.

---

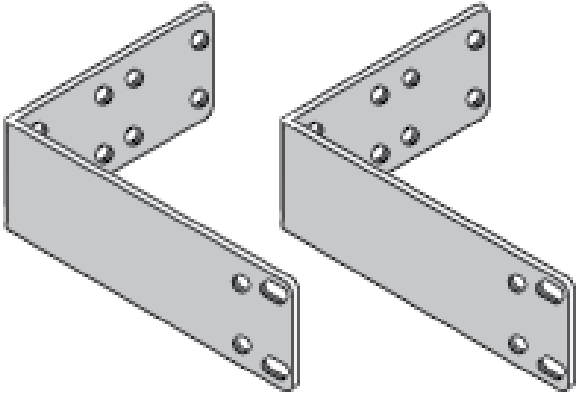
2. Verify that all hardware components are included in your rack mount package listed in Table 7.

Table 7. Components in the AT-RKMT-J14 Rack Mount Kit

	Components
Two Brackets	
Two Handles	
Four M3x6mm screws for handles	
Eight M4x6mm screws	

3. If any item is missing or damaged, contact your Allied Telesis sales representative for assistance.

## Installing a Switch Using the AT-RKMT-J14 Rack Mount Kit

This section shows you steps to install a switch in an equipment rack using the AT-RKMT-J14 kit.

### What to Prepare

Before installing a switch to an equipment rack, make sure that the following items are ready.

- ❑ Two AT-RKMT-J14 rack mount brackets
- ❑ Two AT-RKMT-J14 handles
- ❑ Four M3x6mm screws (Included in the AT-RKMT-J14 kit)
- ❑ Eight M4x6mm screws (Included in the AT-RKMT-J14 kit)
- ❑ Four screws for the equipment rack
- ❑ Phillips-head screw driver

### Installing a Switch Using the Rack Mount Kit

To install a switch in a rack using the AT-RKMT-J14 rack mount kit, perform the following procedure:

1. Review “Reviewing Safety Precautions” on page 26 and “Selecting a Site and Planning the Installation” on page 29 before performing this procedure.
2. Place all the items from the packaging on a work table.
3. Attach the handles to the brackets as shown in Figure 19.

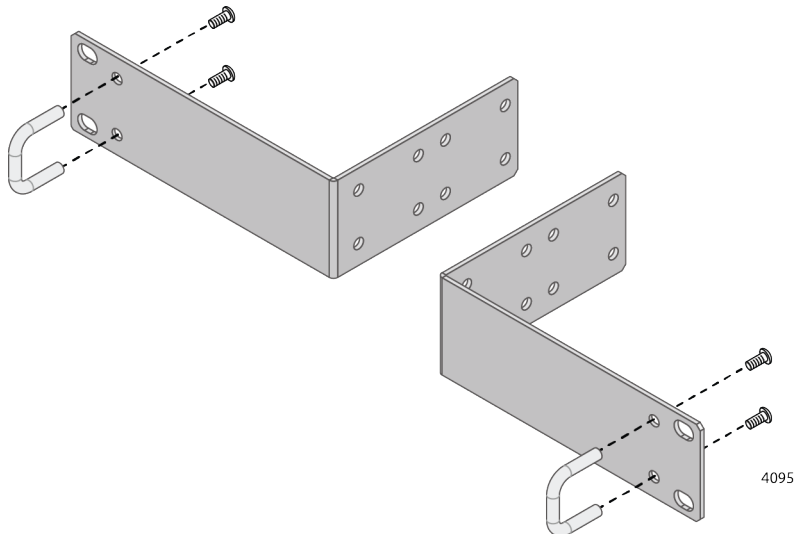

Figure 19. Attaching the Handles to the Brackets

4. Attach the two rack mount brackets to the sides of the switch with the eight bracket screws as shown in Figure 20.

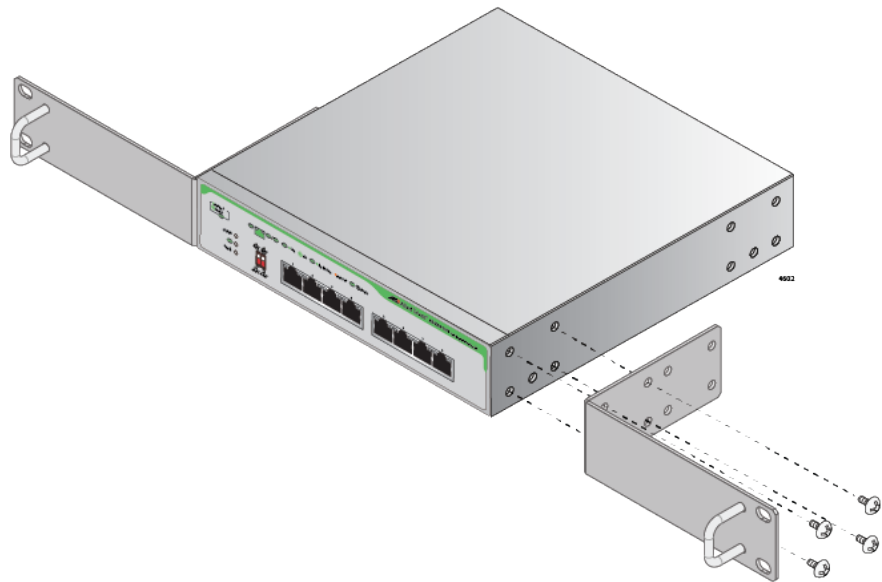

Figure 20. Installing the Brackets on the Switch

5. While another person holds the switch in the equipment rack, secure it with standard equipment rack screws as shown in Figure 21.

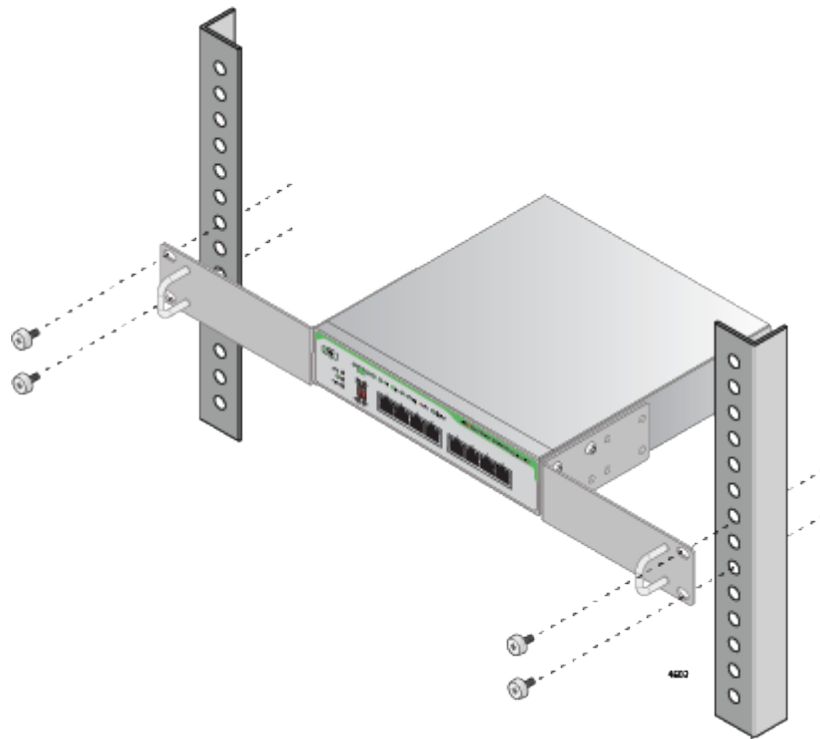

Figure 21. Mounting the Switch in an Equipment Rack

## Chapter 5

# Installation Using the AT-RKMT-J15 Rack Mount Kit

---

This chapter contains the follows sections:

- “Unpacking the AT-RKMT-J15 Rack Mount Kit” on page 52
- “Installing Two Switches in a Row of the Equipment Rack” on page 53

## Unpacking the AT-RKMT-J15 Rack Mount Kit

To unpack the AT-RKMT-J15 rack mount kit, perform the following procedure:

1. Remove all components from the shipping package.

---



**Note**

Store the packaging material in a safe location. You must use the original shipping material if you need to return the unit to Allied Telesis.

---

2. Verify that One pair of brackets is included in your wall mount package listed in Table 8.

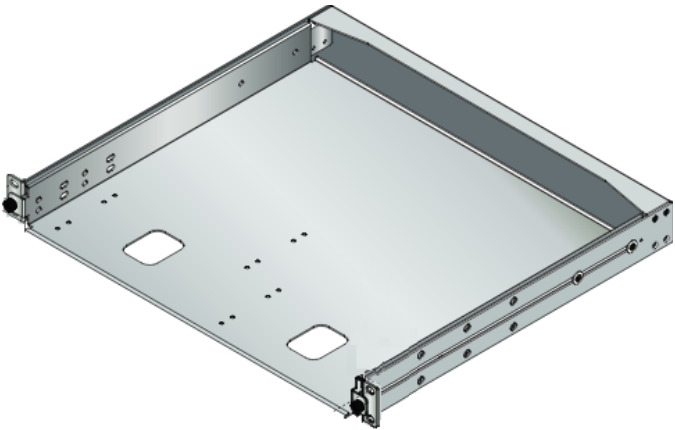
Table 8. Components in the AT-RKMT-J15 Wall Mount Kit

	Components
Tray	
Four M4x6mm screws	

3. If any item is missing or damaged, contact your Allied Telesis sales representative for assistance.

## Installing Two Switches in a Row of the Equipment Rack

This section shows you steps to install two switches on a row of the equipment rack using the AT-RKMT-J15 rack mount kit.

### What to Prepare

Before installing two switches on a row of the equipment rack, make sure that the following items are ready.

- ❑ One AT-RKMT-J15 tray
- ❑ Four M4x6mm screws (Included in the AT-RKMT-J15 kit)
- ❑ Four screws for the equipment rack (Not included)
- ❑ Phillips-head screwdriver (Not included)

### Installing Two Switches in a Row of the Equipment Rack

To install the switch on a wall, perform the following procedure:

1. Review “Reviewing Safety Precautions” on page 26 and “Selecting a Site and Planning the Installation” on page 29.
2. Place all the items from the packaging on a work table.
3. Mount the AT-RKMT-J15 tray in a 19-inch equipment rack using four equipment rack screws. See Figure 22

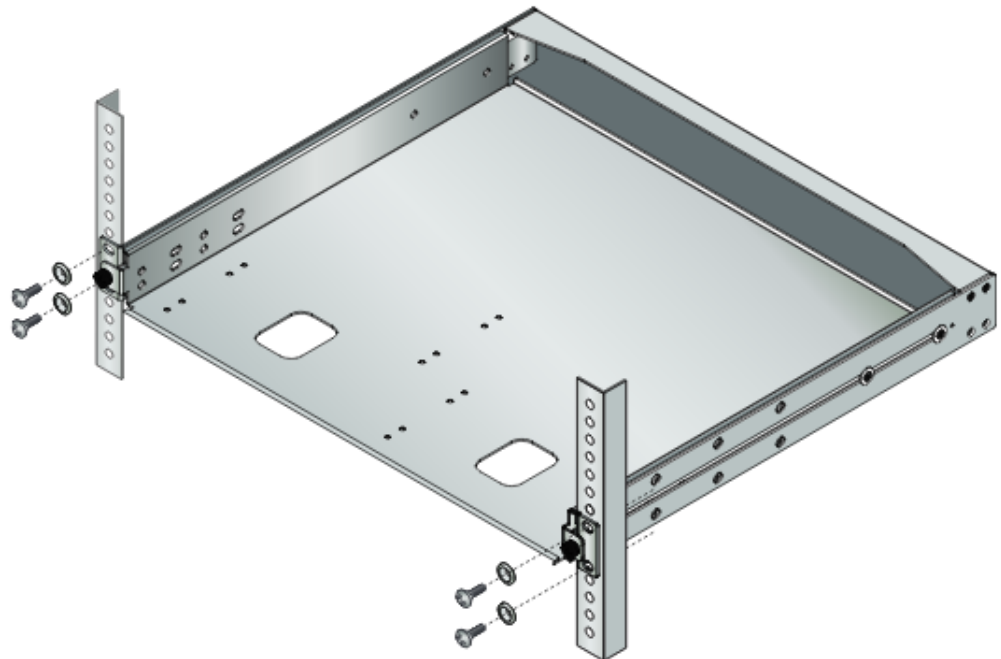

Figure 22. Installing the AT-RKMT-J15 Tray in an Equipment Rack

4. Turn the tray fixing screws on counter clockwise and pull out the tray. See Figure 23.

You can draw the tray to a maximum of 250mm from the tray chassis.

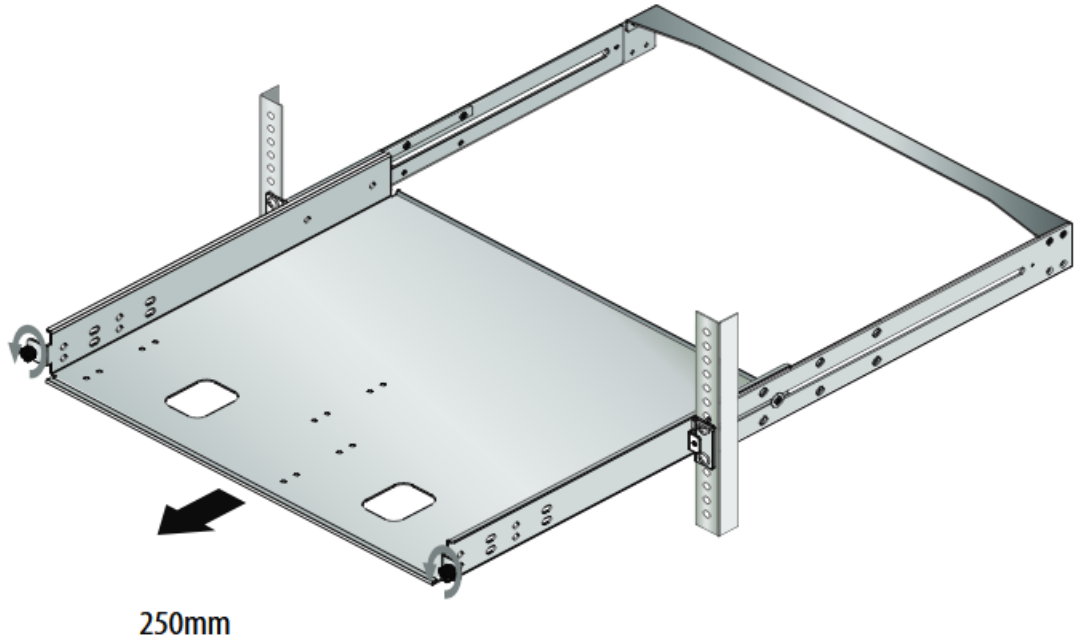

Figure 23. Pulling out the AT-RKMT-J15 Tray

5. Place a switch in the tray and secure the switch to the tray with the head screws through the holes on the slide rail weld. See Figure 24 on page 55.

---

**Note**

Install one switch at a time.

---

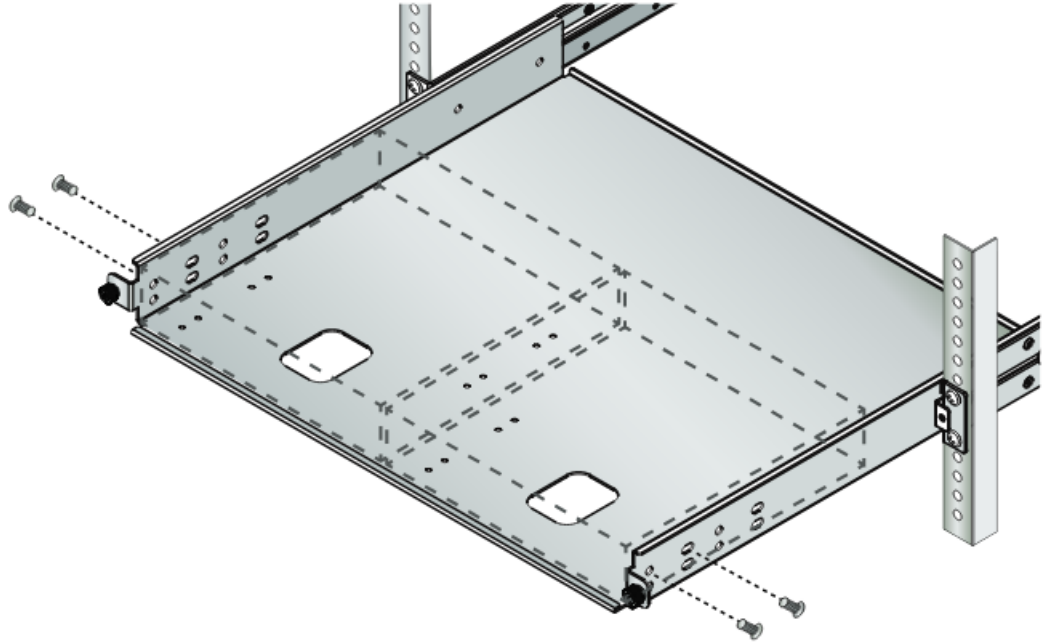

Figure 24. Placing the Switch in the AT-RKMT-J15 Tray

6. Slide the tray back to its original position and turning the tray fixing screws on clockwise as shown in Figure 25.

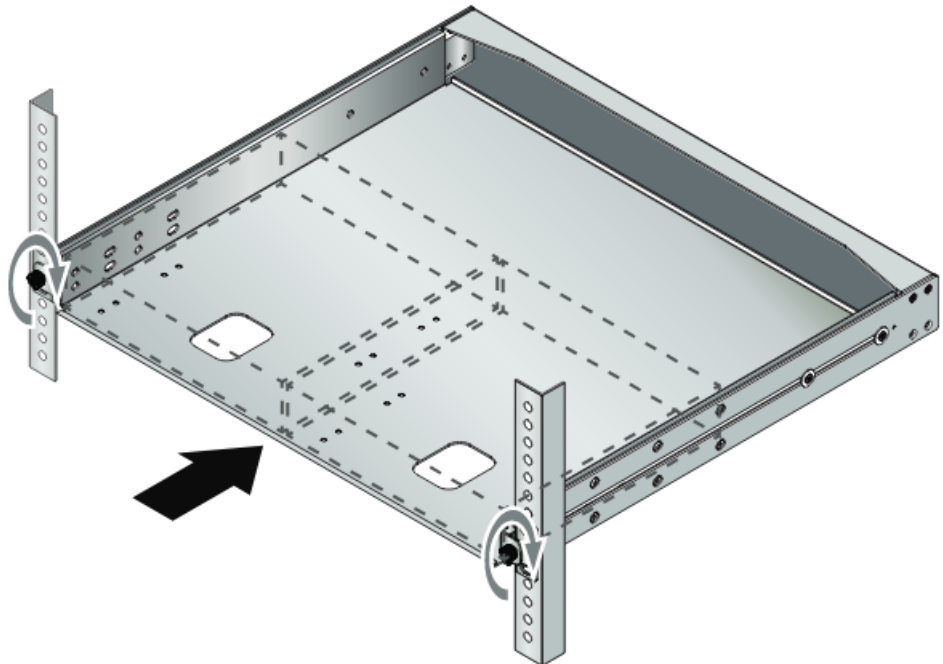

Figure 25. Securing the AT-RKMT-J15 Tray in an Equipment Rack



## Chapter 6

# Troubleshooting

---

This chapter contains information on how to troubleshoot the switch in the event a problem occurs.

---

**Note**

If you are still unable to resolve the problem after following the instructions in this chapter, contact Allied Telesis Technical Support for assistance. Refer to “Contacting Allied Telesis” on page 9.

---

Check the POWER LED on the front of the switch. If the LED is OFF, indicating that the unit is not receiving power, do the following:

- Verify that the power cord is securely connected to the power source and to the connector on the back panel of the switch.
- Verify that the power outlet or power supply has power by connecting another device to it.
- Try connecting the unit to another power source.
- Try using a different power cord.
- Verify that the voltage from the power source is within the required levels for your region.

Verify that the L/A LED for each port is green. If an L/A LED is OFF, do the following:

- Verify that the end-node connected to the port is powered ON and is operating properly.
- Verify that the twisted pair cable is securely connected to the port on the switch and to the port on the end-node.
- Ensure that the twisted pair cable does not exceed 100 meters (328 feet).
- Verify that you are using the appropriate category of twisted pair cable. For the specifications, see Figure 4 on page 29.



## Appendix A

# Technical Specifications

---

This appendix contains the following sections:

- ❑ “Physical Specifications”
- ❑ “Environmental Specifications”
- ❑ “Power Specifications” on page 60
- ❑ “Power Specifications” on page 60
- ❑ “RJ-45 Twisted Pair Port Connectors” on page 60

## Physical Specifications

---

Table 9. Physical Specifications

Parameter	Specification
Dimensions (W x D x H)	210 mm x 275 mm x 42.5 mm (8.3 in. x 10.8 in. x 1.7 in.)
Weight	2,100 g (4.6 lbs)

## Environmental Specifications

---

Operating Temperature: 0° C to 50° C (32° F to 122° F)

Storage Temperature: -25° C to 70° C (-13° F to 158° F)

Operating Humidity: 5% to 90% non-condensing

Storage Humidity: 5% to 95% non-condensing

## Power Specifications

---

Table 10 lists power specifications.

Table 10. Power Specifications

Parameter	Specification
Rated Input Voltage	100 - 240VAC
Maximum Input Current	0.6 A
Average Input Current	0.42 A
Frequency	50/60Hz

\*These power specifications can be found on the rating label placed at the bottom of the product.

## RJ-45 Twisted Pair Port Connectors

---

Figure 26 illustrates the pin layout to an RJ-45 connectors on the front panel of the switch.

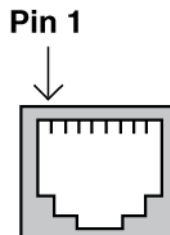

Figure 26. RJ-45 Socket Pin Layout

Table 11 on page 61 lists the pin signals.

Table 11. Pin Signals for 100M/1G/2.5G/5G/10G Base-T Connectors

<b>Pin</b>	<b>100 Mbps MDI Signal</b>	<b>100 Mbps MDI-X Signal</b>	<b>1G/2.5G/5G/10G MDI Signal</b>	<b>1G/2.5G/5G/10G MDI-X Signal</b>
1	TX+	RX+	Bi-directional pair A+	Bi-directional pair B+
2	TX-	RX-	Bi-directional pair A-	Bi-directional pair B-
3	RX+	TX+	Bi-directional pair B+	Bi-directional pair A+
4	Not used	Not used	Bi-directional pair C+	Bi-directional pair D+
5	Not used	Not used	Bi-directional pair C-	Bi-directional pair D-
6	RX-	TX-	Bi-directional pair B-	Bi-directional pair A-
7	Not used	Not used	Bi-directional pair D+	Bi-directional pair C+
8	Not used	Not used	Bi-directional pair D-	Bi-directional pair C-

